

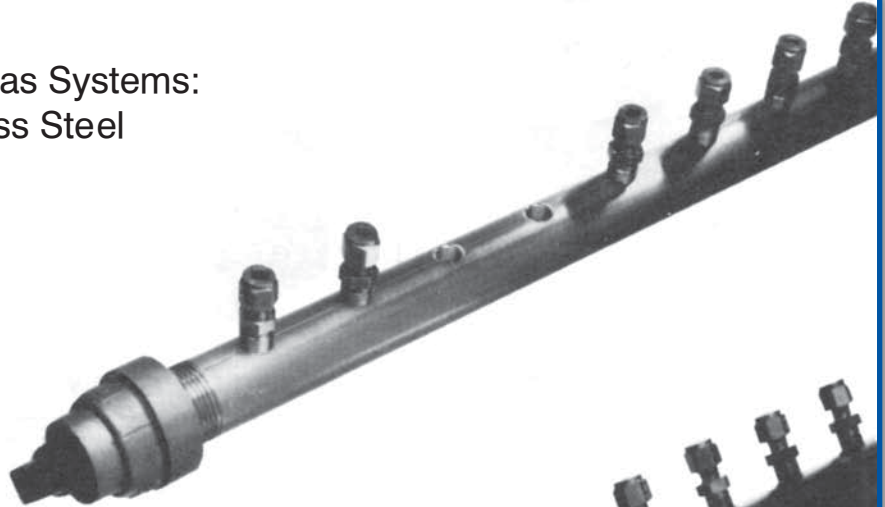

## Instrument Air Headers

Manifolds for Air, Liquid & Gas Systems:  
Aluminum • Brass • Stainless Steel

One (1) Inch  
Tapped One or Both Sides



Two (2) Inch  
Tapped Both Sides  
Cut-Away

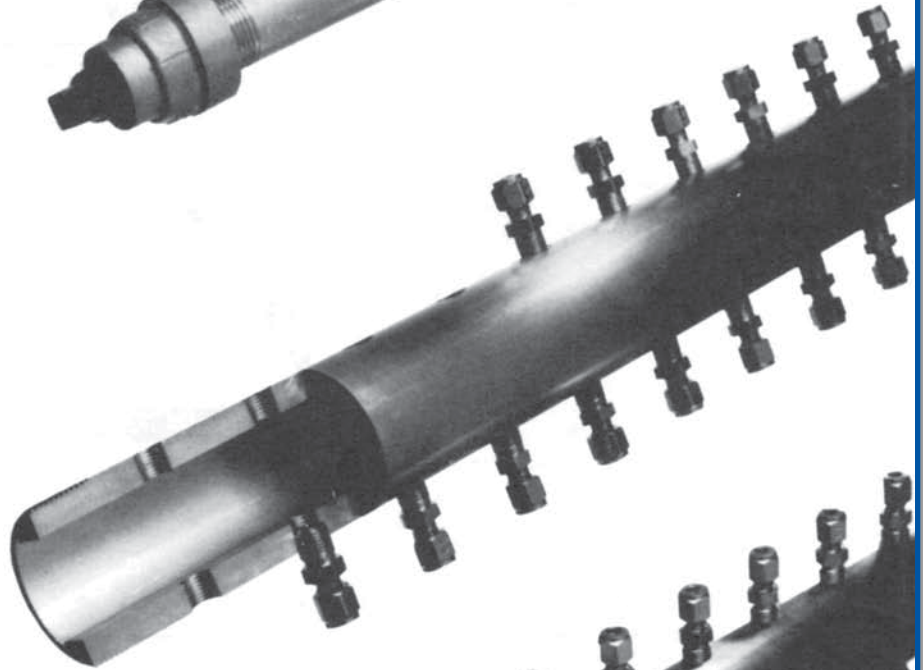

Two (2) Inch  
Tapped Both Sides

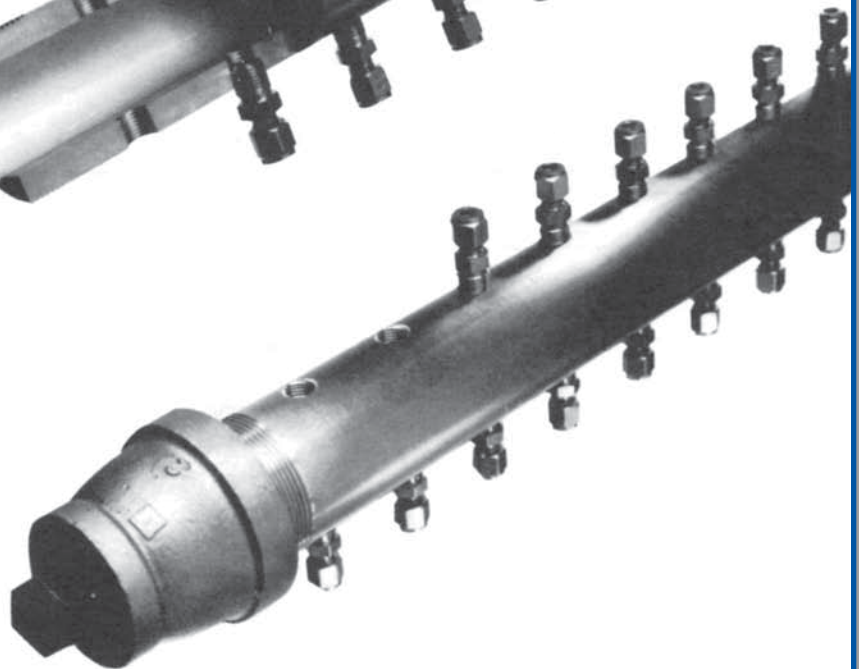



## Maxi-Headers

*Manifolds for Air, Liquid and Gas Systems*

**MAXI-HEADERS** originate from a specially designed aluminum extrusion which allows for full, accurate and secure taps. They are offered in 1" & 2" IPS schedule 40 sizes with lengths up to 20 ft. The tap arrangement is according to customer specifications. Pipe thread end connections are available for one or both ends or may be omitted altogether.

In addition to a neat appearance free of pipe scale, solder lumps or weld flux, the **MAXI-HEADER** offers a clean, smooth interior for fluid flow. The simplicity of the design makes for easy maintenance.

We also offer the header material untapped in 20 ft. lengths.

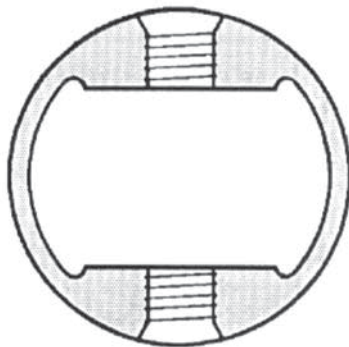

### **PRESSURE - 1" SCHEDULE 40**

- Aluminum 6063-Y6
- Working Pressure: 150 PSI @140° F

### **PRESSURE - 2" SCHEDULE 40**

- Aluminum 6063-Y6
- Working Pressure: 150 PSI @140° F

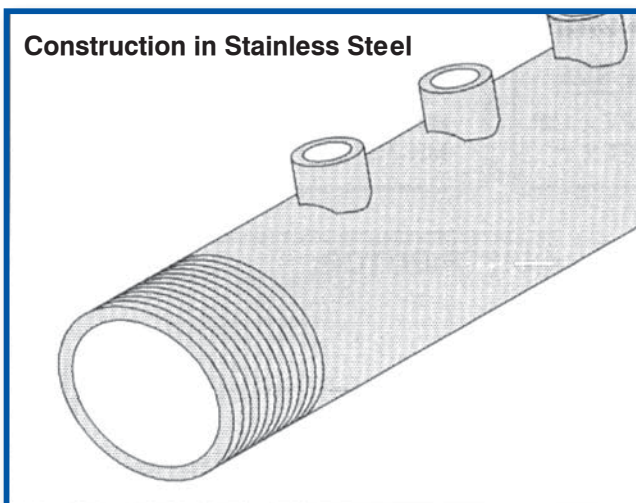

Construction in Stainless Steel

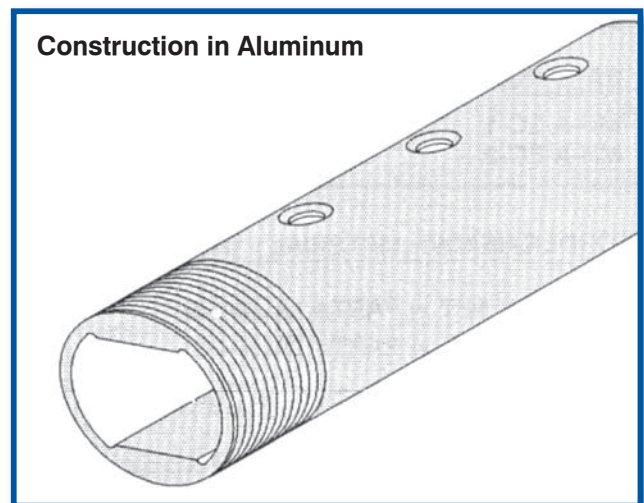

Construction in Aluminum



## How To Order

**Example:**      1 — A — Q — 2.0 — 120 — 4

PIPE SIZE: 1" OR 2"      INCHES FROM END TO TAP

S = STAINLESS  
MATERIAL: A = ALUMINUM  
                  C = CARBON STEEL

OVERALL LENGTH IN INCHES

E = 1/8"  
Q = 1/4"  
TAP SIZE: T = 3/8"      TAP SPACING IN INCHES

**NOTES:**

- Both ends threaded unless otherwise specified by customer
- Tapping most commonly done on one side, but is available on both, diametrically opposed.
- Contact the factory directly, for special tapping arrangements.

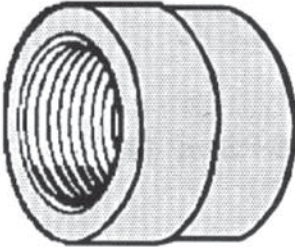
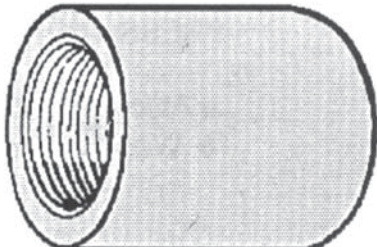
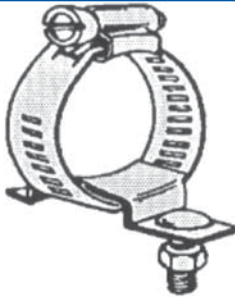
Aluminum End Caps		Reducers		S.S. Mounting Bracket	
					
<u>PART NO.</u>	<u>PIPE SIZE</u>	<u>PART NO.</u>	<u>PIPE SIZE</u>	<u>PART NO.</u>	<u>PIPE SIZE</u>
MH-A-EC-1	1"NPT	MH-A-RC-1	1"NPT x 1/2"	MH-MB-1	1"NPT
MH-A-EC-2	2"NPT	MH-A-RC-2	2"NPT x 1"	MH-MB-2	2"NPT

### TO ORDER HEADER MATERIAL: (20 ft. lengths only)

1" NPT = PART# 1ALM-240

2" NPT = PART# 2ALM-240

*Note: Header comes untapped and unthreaded.*