

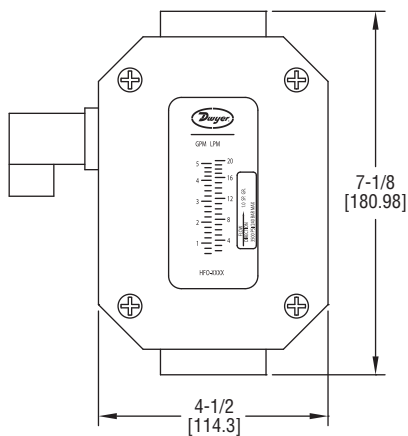

Series HFO Flow Alarm

Specifications – Operating Instructions



Series HFO Flow Alarms are typically used to make or break a set of electrical contacts to signal a limit setting. They may be used to turn on a warning light, sound a bell or horn, or even to shut down a process. The switches on the flow alarm can be configured to open or close a contact for an increasing or decreasing set point. Decreasing flow set points may be located anywhere in the lower 2/3 of the scale while increasing set points may be located anywhere in the upper 2/3 of the scale.

Note: Refer to Series HF In-Line Flow Monitor, Bulletin F-55, "Installation and Operating Instructions" for installation, operation, and cleaning instructions for the basic flow monitor cartridge (included). The following instructions are specifically for the Series HFO Flow Alarm switches.

SPECIFICATIONS

Service: Compatible gases or liquids.

Wetted Materials: Body: Aluminum, brass or 304 SS; Seals: Buna-N or Fluoroelastomer; Magnet: PTFE coated Alnico; Other internal parts: 304 SS.

Viscosity Limit: 500 SSU.

Temperature Limits: 170°F (76°C).

Pressure Limits: See Chart.

Enclosure Rating: NEMA 4X (IP65).

Accuracy: ±2% FS.

Repeatability: ±1% of full scale.

Switch Type: SPDT, 10A @ 250 VAC; 0.5A @ 125 VDC (resistive), 1/4 hp @ 250 VAC (inductive); 3A @ 125 VAC "L" lamp load.

Shipping Weight: 1/4 to 1/2" female NPT Models: 3 lb (1.4 kg); 3/4 to 1" female NPT Models: 4.5 lb (2.0 kg); 1-1/2" female NPT Models: 12 lb (5.4 kg).

PRESSURE DIFFERENTIAL VS. FLOW RATE

1/4" FEMALE NPT

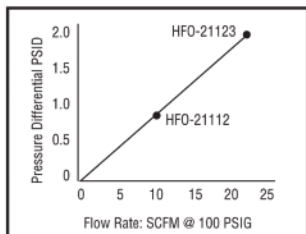

1/2" FEMALE NPT

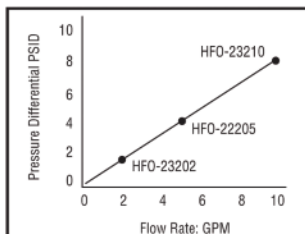

3/4", 1" & 1-1/2" FEMALE NPT

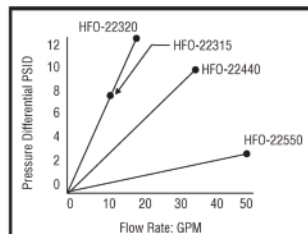

Operation:

Illustration 1 shows the primary mechanism for a single flow alarm. The HFO dual-switch flow alarms contain two sets of these same components (wiring to the DIN connector is described on page 3). The configuration is such that the high alarm is for increasing flow, and the low alarm is for decreasing flow.

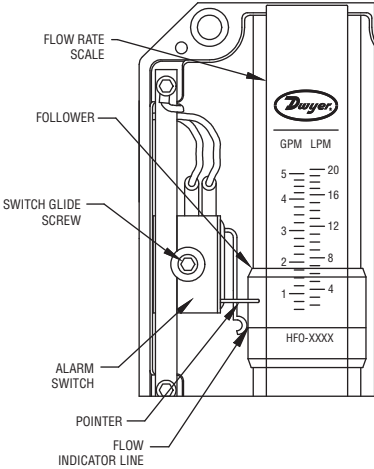

Illustration 1

The follower moves in unison with an orifice plate inside of the unit's pressure vessel via a magnetic coupling in order to indicate flow rate. As the follower moves with changes in flow rate, the flow rate is determined by relating the position of the flow indicator line to the increments on the flow rate scale.

The pointer indicates the set point for the alarm switch. In Illustration 1, the switch will be actuated at all flow rates below 4 GPM. To change the set point, simply loosen the switch glide screw one (1) turn and slide the switch to the desired position along the flow rate scale. When the pointer is pointing to the desired flow rate, re-tighten the switch glide screw.

Switches:

The switch is a simulated roller, lever operated low force microswitch. The specifications for this switch are listed on the first page. The switch is actuated when movement of the follower causes the switch lever to be lifted. In Illustration 2, the switch has not yet been actuated, and the electrical circuit is through the normally closed (NC) contact. Illustration 3 shows the switch after it has been actuated. In this scenario, the electrical circuit is through the normally open (NO) contact.

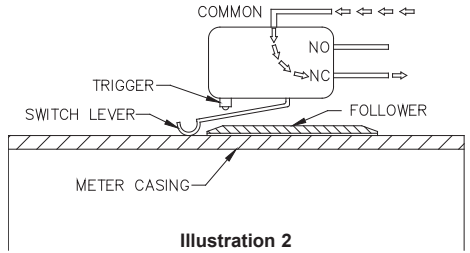

Illustration 2

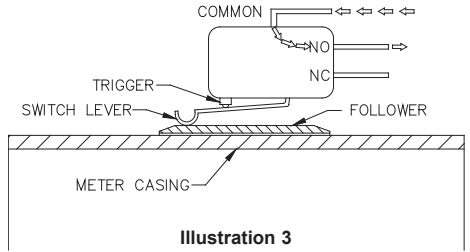

Illustration 3

Precautions:

- Be certain to properly ground the unit via the ground (G) pin located on the unit's DIN connector.
- In order to avoid accidentally removing the switch glide screw, never loosen it by more than one or two turns. This screw can be difficult to replace if accidentally removed.
- Avoid over tightening the switch glide screw.
- When the switch adjustments are complete, make certain that the wires that are attached to the switch have not been moved into a location that will interfere with the follower or the switch lever.
- Do not make any modifications to the unit's internal wiring.

Electrical Connections:

Standard Flow Alarms are pre-wired with 4-pin DIN connectors which consist of a male section as shown in Illustration 4 and the female section shown in Illustration 5. To open the female section, first remove the screw, then lift the connector portion out of the casing by inserting the head of a screwdriver into the slot marked for that purpose. Illustration 6 shows the disassembled female section.



Illustration 4



Illustration 5

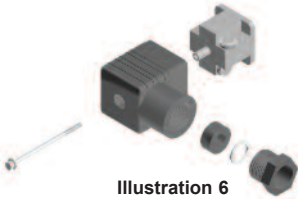

Illustration 6

Illustration 7 shows the connections for the low alarm switch as the unit is shipped from the factory. The wiring code below identifies how the DIN connector is configured for dual alarms. If the NC contacts are needed for either switch, a simple adjustment must be performed. On the switch itself, disconnect the NO lead from the quick connect terminal, and place it onto the NC contact. This will change the operating condition of that particular alarm switch.

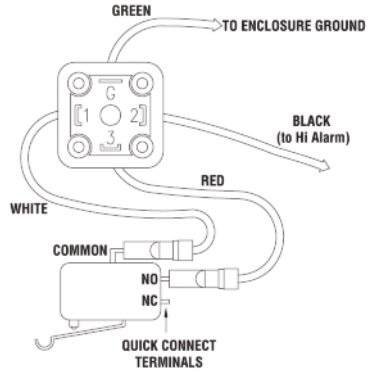

Illustration 7, Low Alarm

Wiring Code: Dual Switch Alarm

White	Both Common	Terminal #1 of DIN
Black	Decreasing N.O. Contact	Terminal #2 of DIN
Red	Increasing N.O. Contact	Terminal #3 of DIN
Green	Enclosure Ground	Terminal "G" of DIN

STANDARD CONTROL CIRCUITS

