

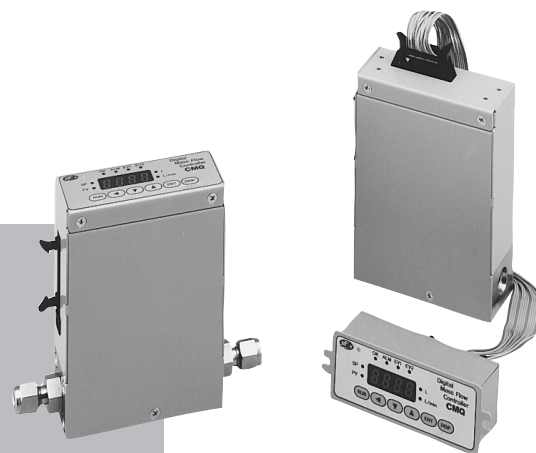

Digital Mass Flow Controller Standard Gas Model

MQV9005/9020/9200/9500
0002/0005/0020/0050/0200/0500

User's Manual

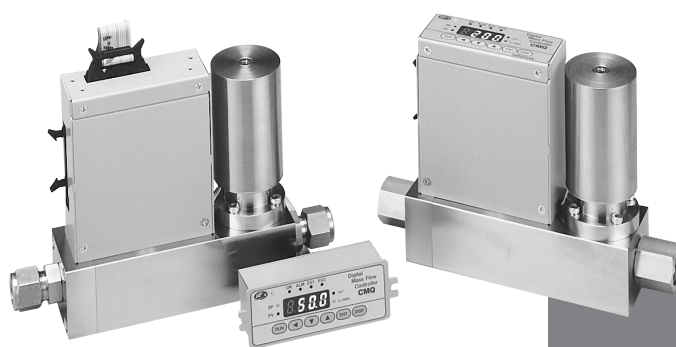

Thank you for purchasing this Azbil Corporation product.

This manual contains information for ensuring correct use of this product. It also provides necessary information for installation, maintenance, and troubleshooting.

This manual should be read by those who design and maintain devices that use this product. Be sure to keep this manual nearby for handy reference.

Azbil Corporation

NOTICE

Be sure that the user receives this manual before the product is used.

Copying or duplicating this user's manual in part or in whole is forbidden. The information and specifications in this manual are subject to change without notice.

Considerable effort has been made to ensure that this manual is free from inaccuracies and omissions. If you should find an error or omission, please contact Azbil Corporation.

In no event is Azbil Corporation liable to anyone for any indirect, special or consequential damages as a result of using this product.

© 2006-2017 Azbil Corporation All Rights Reserved.

Micro Flow™, μF ™ are trademarks of Azbil Corporation in Japan.

SAFETY PRECAUTIONS

■ About Icons

The safety precautions described in this manual are indicated by various icons. Please be sure you read and understand the icons and their meanings described below before reading the rest of the manual.

Safety precautions are intended to ensure the safe and correct use of this product, to prevent injury to the operator and others, and to prevent damage to property. Be sure to observe these safety precautions.



 **WARNING**

Warnings are indicated when mishandling this product might result in death or serious injury.

 **CAUTION**

Cautions are indicated when mishandling this product might result in minor injury to the user, or only physical damage to the product.

■ Examples

	Use caution when handling the product.
	The indicated action is prohibited.
	Be sure to follow the indicated instructions.

WARNING



Never allow gases that are within explosive limits to pass through this device. Doing so might result in an explosion.



If the MQV is to be used for oxygen, make sure that it is a model designed for oxygen use. Even if a device is designed for oxygen gas, do NOT use it for oxygen gas if it has been used for some other gas even once. Oil contained in another gas may be deposited on the gas-contacting parts and ignite upon reacting with oxygen.

CAUTION



If the device is used for burner air-fuel ratio control, take the necessary countermeasures with the equipment to prevent the occurrence of backfire and to avoid any influence to the device even if backfire occurs. Pressure increase or fire in the pipes caused by the backfire of the burner could damage the controller.



This device cannot be used for measurement or control of hydrogen or helium gas. Use a model specially designed for hydrogen and helium gases. For information on whether this device can be used for gases other than the standard compatible gases, be sure to contact the azbil Group in advance.



Prevent foreign matter from entering the device. If rust, water droplet, oil mist, or dust in the pipes enters the device, measurement or control error or damage might occur.

If there is a possibility of foreign matter entering the device, provide a filter, strainer or mist trap capable of eliminating foreign matter 0.1 μm or greater in diameter at the upstream. Be sure to inspect and replace the filter at regular intervals.



Use this device within the operating differential pressure range. Not doing so may cause hunting. Continuous hunting could damage the valve.



Do not subject this device to pressure above its pressure resistance. Doing so might damage it.



Be sure to use within the flow-rate range stipulated in the product specifications.

To prevent excessive flow, use a suitable means to control the supply pressure or use a throttle valve or the like to control the flow rate. If the flow rate exceeds the upper limit, both the flow rate display and the output voltage/current may indicate considerably lower values than the actual flow rate.

CAUTION



If damage could result from the abnormal functioning of this device, include appropriate redundancy in the system design.



The valve on this device cannot completely shut a flow off. If complete shutoff is required, provide a shutoff valve separately. When the external valve is closed, it is necessary also to fully close the valve of the device using either of the following methods:

- Set the flow rate setpoint to zero.
- Make the valve operation mode to fully closed.

If this valve remains in normal control status when the external shutoff valve is closed (zero flow rate), there will be an excessively large flow as soon as the external shutoff valve is opened. For the MQV0050(J, K), MQV0200(J, K), and MQV0500(J, K), if the external shutoff valve is closed continuously for 5 minutes or more in control mode or with the valve forced fully open, the valve overheating limit (AL71) will be activated and the current to the valve will be forcibly limited.



Before connecting pipes with Swagelok or VCR connections, check the precautions in the instruction provided by the connecting joint manufacturer.

When separately purchasing a connecting joint, use the following made by Swagelok Co., Ltd:

- | | |
|----------------|----------------------------------|
| 1/4" Swagelok: | SS-400-1-6ST (standard) |
| | SS-400-1-6STSC11 (oil-inhibited) |
| 1/2" Swagelok: | SS-810-1-8ST (standard) |
| | SS-810-1-8STSC11 (oil-inhibited) |
| 1/4" VCR: | SS-4-VCR-1-00032SC11 |
| 3/8" VCR: | SS-8-VCR-1-8STSC11 or equivalent |



Observe the following when using the device (oil-free model) for oxygen gas:

- Piping should be carried out by a specialist skilled in handling oxygen gas.
- Use oil-free pipes and parts.
- Be sure to remove foreign matter, burrs, etc. from the pipes before connecting the device.



The device is a precision instrument. Do not drop it or subject it to impact, or it might be damaged.



When installing joints (UNF connections), secure the lower part of the body in a vise or the like gripped between rags to protect the finished surfaces, and turn the joint to tighten.



Mount securely in order to prevent vibration. Otherwise, equipment failure could result.

CAUTION



Mount the device horizontally. Do not mount it with the display facing down. Doing so might cause measurement error or equipment failure.



For the MQV0050(J, K)/0200(J, K)/0500(J, K), use the largest pipe possible in order to reduce pressure loss in the pipes, and do not install any equipment near the MQV that can cause a large pressure loss. If there is a large pressure loss in the pipes or equipment, the pressure of the gas supply to this device (operation differential pressure) will be affected and will fluctuate greatly with the flow rate. This could result in unstable control.



When making the pipe connections, hold the hexagonal part of the connector section and turn the pipe to tighten. After connecting, check that there are no gas leaks.



If using Rc connections, take care not to coat with too much sealant. Foreign matter or burrs in the pipes may also cause measurement errors.



Do not apply a negative voltage or a voltage exceeding 5V to the external setup voltage input terminal. Doing so might cause malfunction or equipment failure.



When using a relay for external contact input and/or external 3-way switching input, always use a relay designed for micro-current use (with gold contacts). Failure to do so could cause faulty contact, resulting in malfunction.



If there is a risk of a power surge caused by lightning, use a surge protector to prevent fire or equipment failure.



Gas type switching by external contact input, flow rate switching, and analog input/output voltage range switching by external 3-way input switching should be done only after setting the operation mode to fully closed. Switching while controlling could cause large fluctuations.



Be sure to check that the wiring is correct before turning the power on. Incorrect wiring could cause damage or malfunction.



Do not operate the console keys using a sharp object such as a mechanical pencil or screwdriver. Doing so might damage the console.



When discarding the device, dispose of it as industrial waste, following local regulations.

The Role of This Manual

Two manuals are available for the MQV. Read them as necessary for your specific requirements. If a manual you require is not available, contact the azbil Group or its dealer.

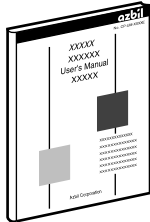

Digital Mass Flow Controller Standard Gas Model

MQV9005/9020/9200/9500/0002/0005/0020/0050/0200/0500

Manual No. CP-SP-1204E

This manual.

First-time users of the MQV, and those in charge of maintenance or hardware design for incorporating a MQV controller in instrumentation should read this manual.

This manual outlines the product, tells how to install, wire, and incorporate the product into instrumentation, and describes its operation, inspection and maintenance, troubleshooting, and hardware specifications.

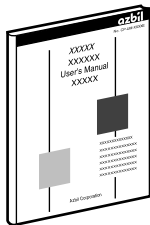

MQV9005/9020/9050/9200/9500/0002/0005/0010/0020/0050/0100/0200/0500

Digital Mass Flow Controller User's Manual for Communication Functions

Manual No. CP-SP-1197E

Personnel who use this device's communications functions should read this manual. The manual gives an overview of communications, describes wiring, transmission protocols, communications data, and troubleshooting, and gives communications specifications.

Organization of the User's Manual

This manual is organized as follows:

Chapter 1. INTRODUCTION

This chapter briefly describes this device and its features, and gives a model selection guide.

Chapter 2. NAMES AND FUNCTIONS OF PARTS

This chapter describes the names and functions of this device's parts.

Chapter 3. MOUNTING AND WIRING

This chapter describes installation, mounting, wiring and initial settings of this device.

Chapter 4. BASIC OPERATION

This chapter gives the basis of how to operate this device.

Chapter 5. ADVANCED OPERATION

This chapter describes how to set functions, parameters, controller information display, and flow rate range.

Chapter 6. MAINTENANCE AND TROUBLESHOOTING

This chapter describes how to investigate and remedy trouble that may occur during operation of this device.

Chapter 7. SPECIFICATIONS

This chapter describes the device's specifications and external dimensions.

Contents

SAFETY PRECAUTIONS

The Role of This Manual

Organization of the User's Manual

Conventions Used in This Manual

Chapter 1. INTRODUCTION

- Introduction 1-1
- Features 1-1
- Functions 1-2
- Model selection guide..... 1-7
- Basic operation and advanced operation 1-10

Chapter 2. NAMES AND FUNCTIONS OF PARTS

Chapter 3. MOUNTING AND WIRING

- Mounting..... 3-2
- Piping..... 3-6
- Wiring..... 3-7

Chapter 4. BASIC OPERATION

- 4-1 Switching Displays 4-1
 - Basic operation 4-1
- 4-2 Setting the Flow Rate 4-4
 - Digital flow rate setup..... 4-5
 - Flow rate setup by external contact input (Advanced use)..... 4-7
 - Flow rate setup by external 3-way switching input (Advanced use)... 4-8
 - Analog flow rate setup 4-9
- 4-3 Selecting the Operating Mode 4-10
 - Operating mode selection 4-10
 - Operating mode display 4-10

Chapter 5. ADVANCED OPERATION

- Setup mode transition operation..... 5-1
- 5-1 Functions..... 5-2
 - Setup method..... 5-2
 - Function setup items 5-3
- 5-2 Parameters 5-11
 - Setup method..... 5-11
 - Parameter setup item list 5-12
- 5-3 Device Information Display 5-15
 - Setup method..... 5-15
 - Device information display item 5-16

5-4	Flow Rate Range Change Function and Settings and Display Resolutions After Change of Range	5-17
■	Setup resolution in the analog setup	5-18

Chapter 6. MAINTENANCE AND TROUBLESHOOTING

■	Alarm code display	6-1
■	Troubleshooting guide.....	6-2

Chapter 7. SPECIFICATIONS

■	Specifications.....	7-1
■	Gas type and control range	7-11
■	Relationship between differential pressure and flow rate.....	7-12
■	Optional parts (sold separately)	7-14
■	External dimensions.....	7-15

Conventions Used in This Manual

The following conventions are used in this manual:



Handling Precautions

Handling Precautions indicate items that the user should pay attention to when using MQV device.



Note

Notes indicate information that might benefit the user.

(1), (2), (3)

Numbers within parentheses indicate steps in a sequence or parts of an explanation.

OFF

This font indicates 7-segment indication on the display.

>>

Indicates the result of an operation or the state of the device after operation.



Indicates an item or page that the user is requested to refer to.

Chapter 1. INTRODUCTION

■ Introduction

MQV high performance, digital mass flow controllers with advanced functions have been developed for the general industrial application. They feature flow rate control with high speed and wide rangeability. MQV controllers integrate three component technologies: the ultra quick response μF (Micro Flow) thermal flow sensor, made with proprietary Azbil Corporation technology, a proportional solenoid valve, and advanced actuator control technology. Integrating these technologies has achieved a high-speed control with low differential pressure.

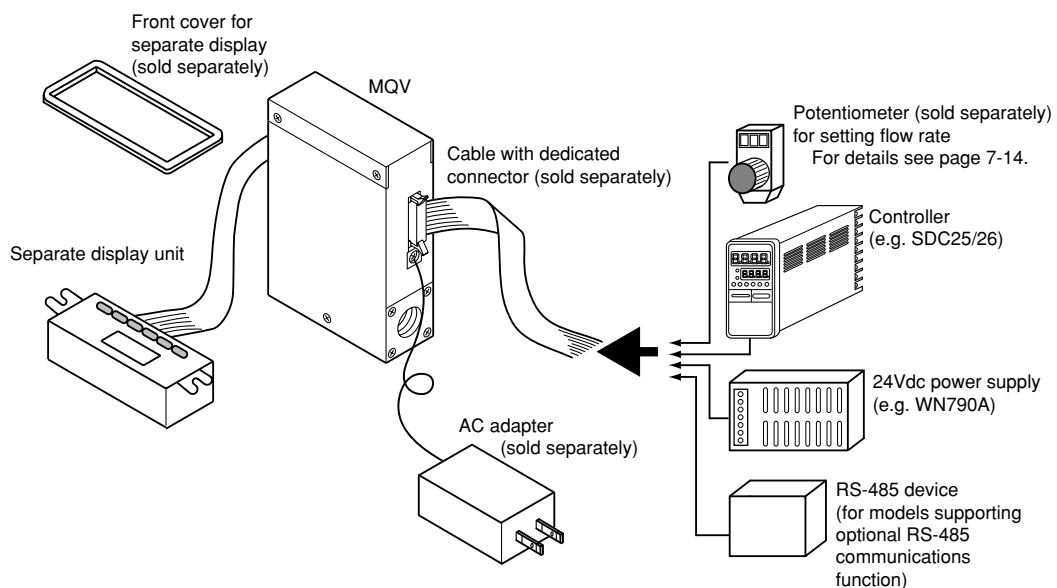

Device Configuration

■ Features

- **High-speed controllability**
 - Fast response of 300ms or less*
(500ms for the MQV9005/9020, 700ms for the MQV0050(J, K), MQV0200, and MQV0500.)
 - * Response time is the time required for the controlled flow rate to reach $\pm 2\%$ of the set value, starting from the fully closed state or from when the set value is changed during control.
- **Low differential pressure operation**
 - MQV controllers can operate at a low differential pressure of 50kPa or less.
- **Wide control range**
 - Wide control range of 1 to 100% FS (2 to 100 % FS for the MQV9005)
- **Wide product line-up**
 - There are two types of models, those with integrated display and those with separate display. On models with separate display, the display unit can be detached to allow remote operation via the dedicated 2m cable.

- **User-friendly**
Runs on a general-purpose 24Vdc power supply, and the MQV's internal power circuit and input/output circuits are isolated. When multiple MQV are driven through the analog inputs and outputs, as with a PLC, they can all use a common power supply even if the PLC's analog modules are not isolated by channel. Therefore, even without individual power supplies for each device, problems with one circuit do not affect adjacent ones. Also provided is a handy AC adapter (sold separately) for easy use in the laboratory.
- **Display direction can be changed (models with integrated display only)**
The direction of the display can be rotated 180° to match the direction of the gas flow, in case it was mounted the other way.
- **Improved design (separate display model)**
A front cover (sold separately) hides the mounting screws of the separate display on the panel surface and improves the appearance.
- **Various additional functions**
The functions listed below are all standard.

■ Functions

All MQV models have the functions described below. For function setup, see Chapter 5, ADVANCED OPERATION.

- **Multi-setup (function setup ①-04)**
Quickly switch to one of eight preset flow set value by key operation or external input. If “Switching of SP No.” is set to external 3-way switching input, up to three set values can be switched.
- **Gas type switching (function setup ①-18, ①-26)**
The gas type to be used can be selected from the standard compatible gases by key operation. Additionally, two kinds of gas type settings can be changed by external contact input.
- **Gas type setup (function setup ①-18)**
The user can set gas type conversion factors for gases other than the standard compatible gases, and for mixed gases.
For information on gas type conversion factors for various gases, contact the azbil Group.
- **Control flow range setting (function setup ①-24, ①-25)**
The control flow range can be changed to the desired range (10 to 100% of the flow range at factory setting) in units of 1% FS. The setup and display resolution levels can be improved by reducing the control flow range. Additionally, two kinds of control flow ranges can be switched through external contact input.
- **Direct setup (function setup ①-27)**
When changing the flow set value by key input, the controlled flow rate can follow the set value while changes are being made (the flow set value can be changed quickly). This function is useful when the user frequently changes set value, for example when adjusting the flow set value during a trial run.

-
- **SP ramp control (function setup $\xi-27$)**
 This function is used to set the set value change ramp amount (the rate of change per second) to a constant value for the start of control and for set value changes. With this function, the set value change ramp amount can be set more precisely than with the slow start function. Two different types of ramps can be set, and there are the following 2 control modes:
 - SP ramp control 1
 In SP ramp-up: Ramp 1
 In SP ramp-down: Ramp 2
 - SP ramp control 2
 In external contact OFF: Ramp 1
 In external contact ON: Ramp 2
 - **SP limit (function setup $\xi-35$)**
 The lower and upper limits of the set value range can be set to desired levels. (This prevents mistaken high/low settings.)
 - **Slow start (function setup $\xi-17$)**
 Sudden changes in the controlled flow rate, when control is started or when the set value is changed, can be suppressed. The control speed can be changed in eight stages within a range of about 1 to 6 seconds.
 - **Flow rate totalization (function setup $\xi-09, \xi-12$)**
 MQV9005: in 0.1mL units
 MQV9020: in 1mL units
 MQV9200/9500: in 0.01L units
 MQV0002/0005: in 0.1L units
 MQV0020/0050: in 1L units
 MQV0050(J, K): in 0.001m³ units
 MQV0200/0500: in 0.01m³ units
 Integrated flow count can be up to eight digits long (to 99,999,999) for each unit. (Display alternates between first and last 4 digits.) The count can be reset by key operation or external contact input. Use of external contact input makes it possible to remotely operate the start, temporary stop, and reset of totalization. When resetting the integrated count by key operation, the count restarts automatically after it has been reset. On the other hand, when resetting with the external contact input (by contact ON), the count restarts when the contact is turned OFF.
 - **Event lamp lighting/output (function setup $\xi-07, \xi-08$)**
 Two of the event types listed below can be selected. Output ON delay time can also be set (but delay cannot be set for totalizer pulse output).
 - Integrated flow event output (when the integrated flow event setting is exceeded.)
 - Totalized pulse output (pulse can be output for each totalizing flow display unit.)
 - OK output (the control flow rate is within the set value \pm allowable range.)
 - Flow rate upper or lower limit output (output in comparison with optional upper or lower limit flow rate set value)
 - Output mode (The four modes — control / fully open / control or fully open / fully closed — can be identified and output.)

- **OK lamp ON/output (function setup ζ -07, ζ -08)**

The OK lamp can be set to light when the control flow rate is within the set value \pm allowable range. This function is very handy for verifying at a glance whether or not there is a proper response to a new set value after its value is changed. OK lamp output can also be used as an interlock signal for subsequent processes by assigning it to event output and including it in a sequence program.
- **PV filter (function setup ζ -23)**

This function is used to average the instantaneous flow rate (control flow rate) detected value. Use of this function makes it possible to suppress effects of slight pressure fluctuations.
- **Control dead band setup (prevention of valve operation) (function setup ζ -22)**

This function is used to stop the valve from driving as long as the control flow rate is within the OK range. Additionally, the OK range (width of dead band) can be set to the desired level.
- **Valve amperage display (function setup ζ -20)**

The electric current supplied to the valve can be displayed in units of 0.0 to 100.0%. Additionally, use of the valve amperage alarm detection function makes it possible to detect an inlet pressure change or clogging of the piping at the outlet.
- **Gas type external switching (function setup ζ -10 to ζ -12, ζ -18, ζ -26)**

Two preset types of gases (including one with a user-determined gas type conversion factor) can be switched by external contact input.
- **Control flow rate range external switching (function setup ζ -10 to ζ -12, ζ -24, ζ -25)**

Two preset control flow ranges can be switched by external contact input.
- **PV forced zero (function setup ζ -29)**

This function forcibly sets the detected instantaneous flow rate to 0 (zero) after the delay time elapses when the flow rate setpoint has been set to 0 (zero) or the valve mode has been changed to fully closed. This function makes it possible to ignore the deviation of the instantaneous flow rate zero point caused by inclination of the piping or the like.
- **Flow rate display unit change (function setup ζ -37)**

This function is used to change the flow rate display unit to L/min or mL/min of the MQV9200/9500/0002/0005. When multiple devices are used side-by-side, this function can make the flow rate display units uniform.
- **PV display decimal point change (function setup ζ -38)**

This function is used to shift the decimal point position of the instantaneous flow rate display one digit left or right. When multiple devices are used side-by-side, the number of digits after the decimal point of the flow rate display can be made uniform.

- Valve forcibly open or close (function setup $\zeta-02$, $\zeta-09$ to $\zeta-12$)
This function is used to forcibly open or close the valve fully by key operation, external contact input, or external 3-way switching input.
- Automatic shut-off (function setup $\zeta-13$, $\zeta-16$)
The valve can be shut off automatically under the following conditions:
 - (1) When the totalized flow count reaches the preset value.
 - (2) When one of the alarms, including flow rate alarms, is triggered.
- ALM (alarm) lamp ON/output/valve shut-off (function setup $\zeta-15$, $\zeta-18$ $\zeta-20$)
The alarm output can be set for high and low deviations in the flow set value and instantaneous flow rate. Additionally, an alarm judgment delay time can also be set. If a flow rate alarm occurs or if an alarm occurs during self-diagnosis of this controller, the valve can be forced fully closed or opened.

Handling Precautions

- The valve on this device cannot completely shut off.
- If complete shutoff is required, provide a shutoff valve separately.
- Automatic reset of cumulative count at start of control function (function setup $\zeta-14$)
Start of control and reset of totalized flow count can be done simultaneously by a single action (by key or external switching input). Combining this function with the automatic shut-off function described above is handy for shutting the valve off in cases where a fixed totalized flow amount is counted repeatedly.
- Analog scaling (function setup $\zeta-28$)
This function is used to optionally change the flow rate (between 10% FS and 100% FS) corresponding to 100% FS analog input/output (5V or 20mA).
- Analog input (flow set value) range selection (function setup $\zeta-05$, $\zeta-09$)
In analog setup, the desired input range can be selected from those shown below either by key operation or by external 3-way switching input. When doing so, the voltage input and current input are selected automatically, as they are linked with the settings of function setup $\zeta-05$ (analog output type selection). For example, when the voltage output (0 to 5V or 1 to 5V) is selected in $\zeta-05$, the voltage input is selected automatically. Likewise, when the current output (0 to 20mA or 4 to 20mA output) is selected, the current input is selected automatically.
 - (1) Internal reference 0 to 5V input*/External reference 0 to 20mA input
 - (2) External reference 0 to 5V input/External reference 0 to 20mA input
 - (3) External reference 1 to 5V input/External reference 4 to 20mA input

* The internal reference 0 to 5V is used when the 5V output terminal voltage (pin No. 20) of this controller is used as the reference.

- Analog output type/range selection (function setup $\xi-05, \xi-09$)
Output can be set either to instantaneous flow rate (PV) or flow set value (SP). Furthermore, a voltage/current output range can be selected from (1) to (4) shown below by key operation. Additionally, (1)/(2) or (3)/(4) can be changed through the external 3-way switching input. (Combinations are switched because of linkage with the analog input range selection.)

Instantaneous flow rate (PV) output

- (1) 0 to 5V output
- (2) 1 to 5V output
- (3) 0 to 20mA output
- (4) 4 to 20mA output

Flow set value (SP) output

- (1) 0 to 5V output
- (2) 1 to 5V output
- (3) 0 to 20mA output
- (4) 4 to 20mA output

■ Model selection guide

● MQV9005/9020

Basic model No.	Standard control flow-rate range	Display	Material of gas-contacting parts	Connection method	Gas type	Optional functions					Append- ed No.	Description		
						1	2	3	4	5				
MQV												Digital mass flow controller, MQV		
	9005											0.10 to 5.00 mL/min (standard) *1, *4		
	9020											0.2 to 20.0 mL/min (standard) *1, *4		
		B										Integrated display (body length 90mm)		
		C										Separate display (body length 90mm)		
			S									SUS316		
				S								1/4" Swagelok		
				V								1/4" VCR		
					N							Air, nitrogen *2, *4		
					S							Oxygen *3, *4		
						0						Without optional functions		
							0					Without optional functions		
								1				Model with RS-485 communications (CPL) function		
									0			Without optional functions		
										0		Without optional functions		
											1	Gas-contacting parts treated to be oil free *5		
												0	Without optional functions	
												D	With inspection certificate	
												Y	With traceability certificate	
													0	Product version

- *1. mL/min (standard) indicates the volumetric flow rate per minute (mL/min) converted to conditions of 20°C and 101.325 kPa (1 atm). The reference temperature can be changed to 0, 25, or 35°C.
- *2. Air/nitrogen is the factory setting. By changing the setting, this model can be used for argon.
- *3. Oxygen is the factory setting. By changing the setting, this model can be used for air/nitrogen, argon. However, once this device has been used for gas other than oxygen, never reuse it for oxygen.
- *4. The flow rate ranges in the table are for use of this device with air. The controllable flow range may vary depending on the type of gas.
See "Gas type and control range" (page 7-11).
- *5. When oxygen is selected as the gas type, selection "1," "gas-contacting parts treated to be oil free," must be selected for Optional function 4.

● MQV9200/9500/0002/0005/0020/0050

Basic model No.	Standard control flow-rate range	Display	Material of gas-contacting parts	Connection method	Gas type	Optional functions					Append- ed No.	Description		
						1	2	3	4	5				
MQV												Digital mass flow controller, MQV		
	9200											2 to 200 mL/min (standard) *1, *4		
	9500											0.004 to 0.500L/min (standard) *1, *4		
	0002											0.02 to 2.00L/min (standard) *1, *4		
	0005											0.04 to 5.00 L/min (standard) *1, *4		
	0020											0.2 to 20.0 L/min (standard) *1, *4		
	0050											0.4 to 50.0 L/min (standard) *1, *4		
		B										Integrated display (body length 90mm)		
		C										Separate display (body length 90mm)		
			S									SUS316		
				R								Rc 1/4"		
				S								1/4" Swagelok		
				V								1/4" VCR		
				U								9/16-18UNF		
					N							Air, nitrogen *2, *4		
					S							Oxygen *3, *4		
						0						Without optional functions		
							0					Without optional functions		
								1				Model with RS-485 communications (CPL) function		
									0			Without optional functions		
										0		Without optional functions		
											1	Gas-contacting parts treated to be oil free *5		
												0	Without optional functions	
												D	With inspection certificate	
												Y	With traceability certificate	
													0	Product version

- *1. L/min (standard) and mL/min (standard) indicate the volumetric flow rate per minute (L/min and mL/min) converted to conditions of 20°C and 101.325 kPa (1 atm). The reference temperature can be changed to 0, 25, or 35°C.
- *2. Air/nitrogen is the factory setting. By changing the setting, this model can be used for argon, carbon dioxide (CO₂), city gas 13A (LNG: 46MJ/m³), city gas 13A (LNG: 45MJ/m³), propane 100%, methane 100%, or butane 100%. Additionally, semi-standard gas models that can be used for ammonia or acetylene (seal material: EPDM) can also be manufactured.
- *3. Oxygen is the factory setting. By changing the setting, this model can be used for air/nitrogen, argon, carbon dioxide (CO₂), city gas 13A, propane 100%, methane 100%, or butane 100%. However, once this device has been used for gas other than oxygen, never reuse it for oxygen.
- *4. The flow rate ranges in the table are for use of this device with air. The controllable flow range may vary depending on the type of gas.
See “Gas type and control range” (page 7-11).
- *5. When oxygen is selected as the gas type, selection “1,” “gas-contacting parts treated to be oil free,” must be selected for Optional function 4.

● MQV0050(J, K)/0200/0500

Basic model No.	Standard control flow-rate range	Display	Material of gas-contacting parts	Connection method	Gas type	Optional functions					Append- ed No.	Description	
						1	2	3	4	5			
MQV												Digital mass flow controller, MQV	
	0050											0.4 to 50.0 L/min (standard) *1, *4, *6	
	0200											2 to 200 L/min (standard) *1, *4	
	0500											4 to 500 L/min (standard) *1, *4	
		J										Integrated display (body length 150mm)	
		K										Separate display (body length 150mm)	
			S									SUS316	
				R								Rc 1/2"	
				S								1/2" Swagelok	
				V								3/8" VCR	
				U								3/4-16UNF	
					N							Air, nitrogen *2, *4	
					S							Oxygen *3, *4	
						0						Without optional functions	
							0					Without optional functions	
								1				Model with RS-485 communications (CPL) function	
									0			Without optional functions	
										0		Without optional functions	
											1	Gas-contacting parts treated to be oil free *5	
											0	Without optional functions	
											D	With inspection certificate	
											Y	With traceability certificate	
												0	Product version

- *1. The notations mL/min (standard) and L/min (standard) indicate the volume flow rate per minute converted to 20°C, one atmosphere (101.3kPa (abs)). The reference temperature can also be changed to 0°C, 25°C or 35°C.
- *2. Air/nitrogen is the factory setting. By changing the setting, this model can be used for argon, carbon dioxide (CO₂), city gas 13A (LNG: 46MJ/m³), city gas 13A (LNG: 45MJ/m³), propane 100%, methane 100%, or butane 100%. Additionally, semi-standard gas models that can be used for ammonia or acetylene (seal material: EPDM) can also be manufactured. (MQV0200/0500 only)
- *3. Oxygen is the factory setting. By changing the setting, this model can be used for air/nitrogen, argon, carbon dioxide (CO₂), city gas 13A (LNG: 45MJ/m³), propane 100%, methane 100%, or butane 100%. However, once this device has been used for a gas other than oxygen, never reuse it for oxygen.
- *4. The flow rate ranges in the above table are for use of this device for air. The controllable flow range may vary depending on the type of gas.
See "Gas type and control range" (page 7-11).
- *5. When oxygen is selected as the gas type, selection "1," "gas-contacting parts treated to be oil free," must be selected for Optional function 4.
- *6. The MQV0050(J, K) is for low differential pressure and is controllable to a high flow rate range with lower differential pressure than the MQV0050(B, C).

■ Basic operation and advanced operation

This device provides two kinds of operations, basic operation and advanced operation. Basic operation is the state of the device during normal use. In basic operation, the contents of the 7-segment display can be changed to show instantaneous flow rate, flow set value, totalized flow value, or amperage to the valve in normal operation mode. Also, how to set the flow set value is described in the basic operation part.

Advanced operation is for selecting various functions or setting parameters of the device. When the device is used with the factory settings, no setup operation is needed. However, to change the gas type, set a range, set an external contact input, set upper and lower alarm limits, or set communication conditions (for models with communication functions), it is necessary to configure various settings using advanced operation. The diagram below gives an outline of operation flow. Basic and advanced operation are described in Chapters 4 and 5, respectively.

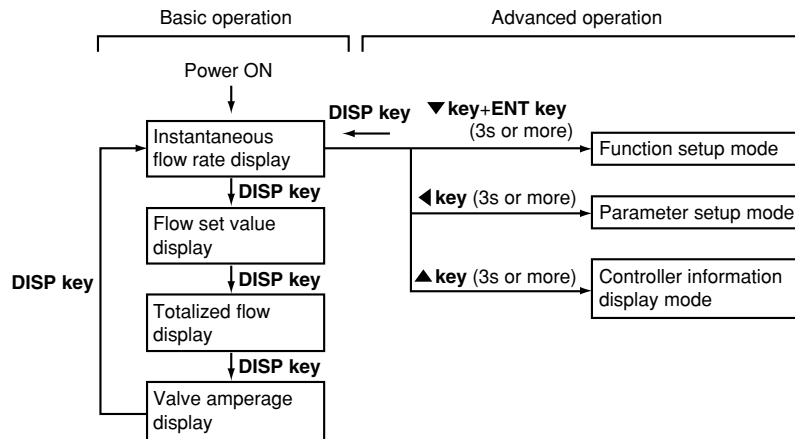

Chapter 2. NAMES AND FUNCTIONS OF PARTS

● Display

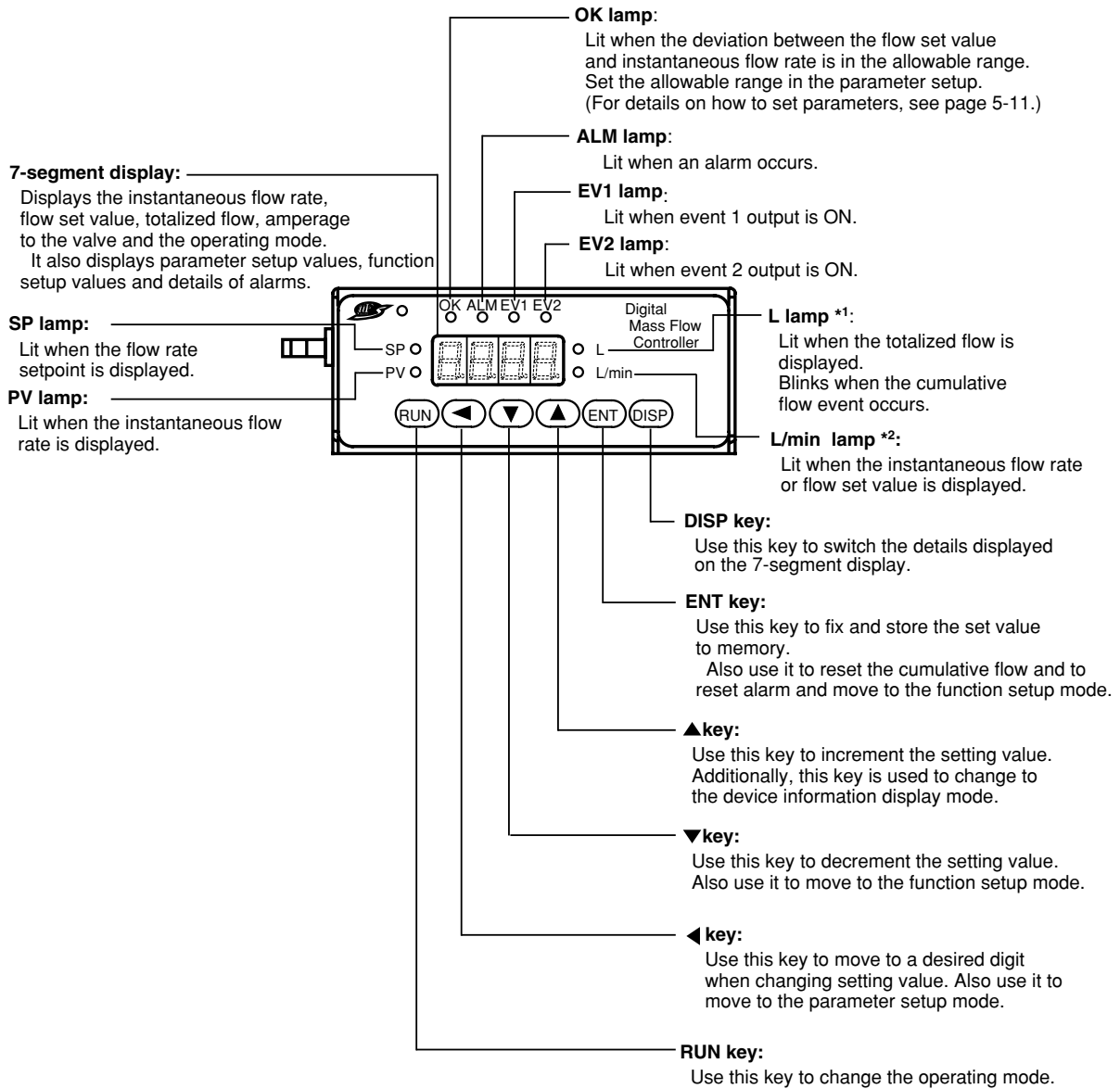

Note

Technical terms used in this manual are defined as follows:

- SP (setpoint): The flow set value (or flow rate setpoint)
- PV (process variable): Instantaneous flow rate (or controlled flow rate)
- Operating mode: One of 3 modes (valve fully closed/valve control/valve fully open)

*1: This lamp is used for mL/m³ instead of L on some models.

*2: This lamp is used for mL/min instead of L/min on some models.

● **Body (MQV9005/9020/9200/9500/0002/0005/0020/0050)**

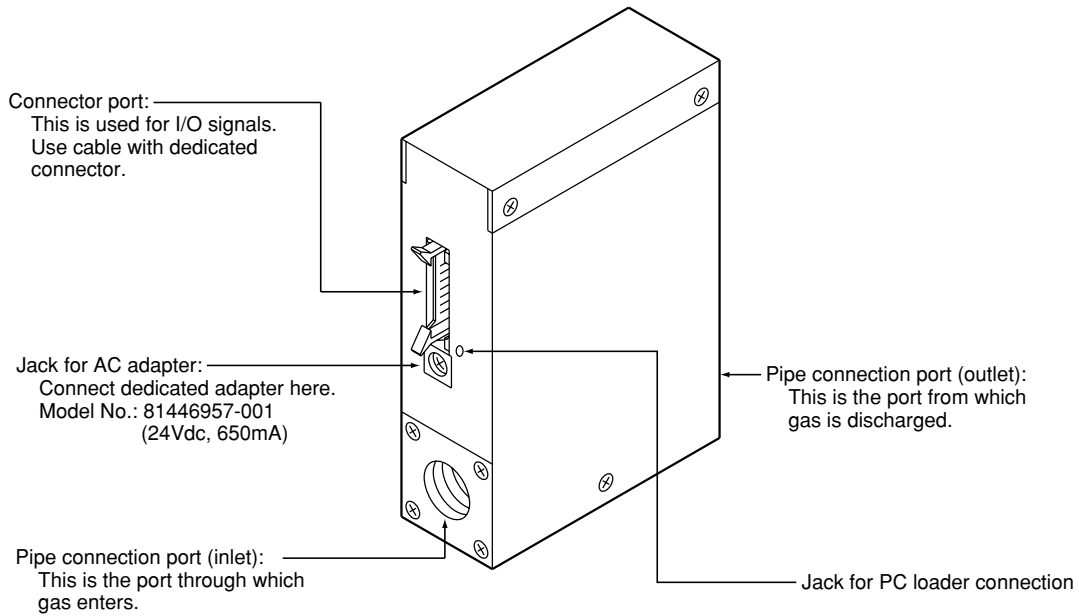

● **Body (MQV0050(J, K) /0200/0500)**

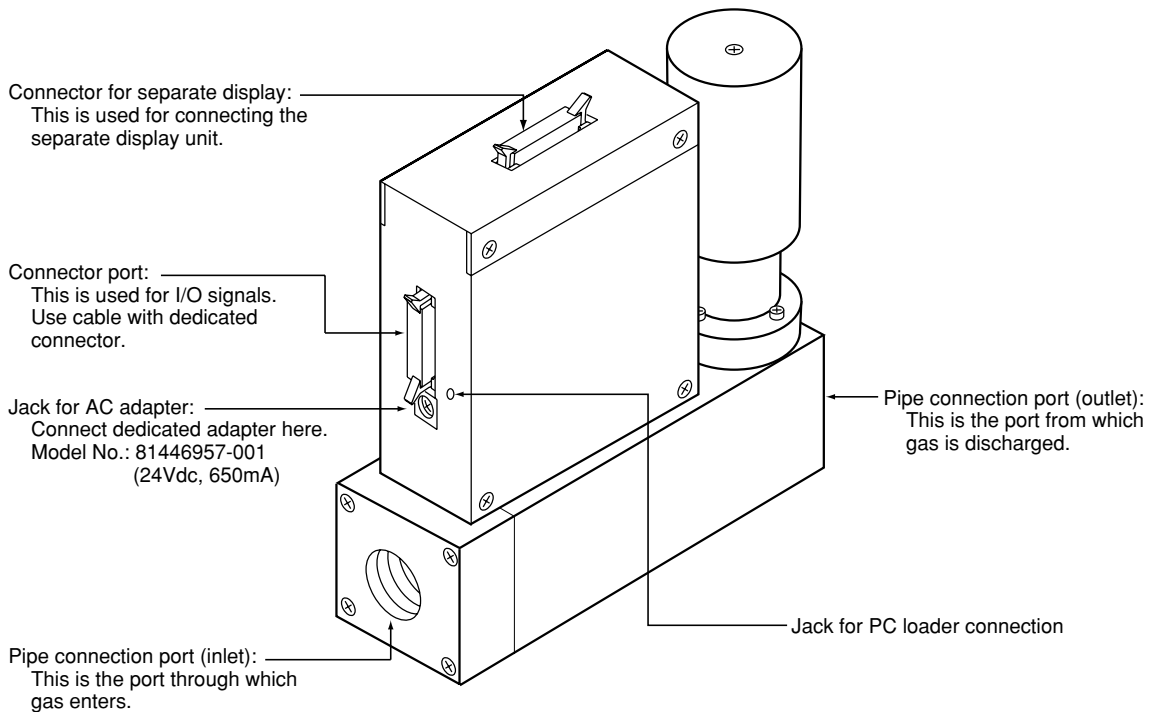



! Handling Precautions







- The former AC adapter (model No. 81446682-001, 15Vdc/350mA) can not be used with MQV.

Chapter 3. MOUNTING AND WIRING

WARNING

-  Never allow gases that are within explosive limits to pass through this device. Doing so might result in an explosion.
-  If the MQV is to be used for oxygen, make sure that it is a model designed for oxygen use. Even if a device is designed for oxygen gas, do NOT use it for oxygen gas if it has been used for some other gas even once. Oil contained in another gas may be deposited on the gas-contacting parts and ignite upon reacting with oxygen.

CAUTION

-  Prevent foreign matter from entering the device. If rust, water droplet, oil mist, or dust in the pipes enters the device, measurement or control error or damage might occur.
If there is a possibility of foreign matter entering the device, provide a filter, strainer or mist trap capable of eliminating foreign matter 0.1 μm or greater in diameter at the upstream. Be sure to inspect and replace the filter at regular intervals.
-  Use the device within the operating differential pressure range. Also, do not subject it to pressure beyond the rated pressure resistance range. Doing so might damage it.
-  Do not subject this device to pressure above its pressure resistance. Doing so might damage it.
-  Be sure to use within the flow-rate range stipulated in the product specifications. To prevent excessive flow, use a suitable means to control the supply pressure or use a throttle valve or the like to control the flow rate.
If the flow rate exceeds the upper limit, both the flow rate display and the output voltage/current may indicate considerably lower values than the actual flow rate.
-  If damage could result from the abnormal functioning of this device, include appropriate redundancy in the system design.
-  The valve on this device cannot completely shut a flow off. If complete shutoff is required, provide a shutoff valve separately. When the external valve is closed, it is necessary also to fully close the valve of the device using either of the following methods:
 - Set the flow rate setpoint to zero.
 - Make the valve operation mode to fully closed.If this valve remains in normal control status when the external shutoff valve is closed (zero flow rate), there will be an excessively large flow as soon as the external shutoff valve is opened. For the MQV0050(J, K), MQV0200(J, K), and MQV0500(J, K), if the external shutoff valve is closed continuously for 5 minutes or more in control mode or with the valve forced fully open, the valve overheating limit (AL71) will be activated and the current to the valve will be forcibly limited.
-  Before connecting pipes with Swagelok or VCR connections, check the precautions in the instruction provided by the connecting joint manufacturer.
When purchasing a connecting joint, use the following made by Swagelok Co., Ltd:
 - 1/4" Swagelok: SS-400-1-6ST (standard)
SS-400-1-6STSC11 (oil-inhibited)
 - 1/2" Swagelok: SS-810-1-8ST (standard)
SS-810-1-8STSC11 (oil-inhibited)
 - 1/4" VCR: SS-4-VCR-1-00032SC11
 - 3/8" VCR: SS-8-VCR-1-8STSC 11 or equivalent

CAUTION



Observe the following when using this device (oil-free model) for oxygen gas:

- Piping should be carried out by a specialist skilled in handling oxygen gas.
- Use oil-free pipes and parts.
- Be sure to remove foreign matter, burrs, etc. from the pipes before connecting the device.
- Install a filter upstream of the device.



The device is a precision instrument. Do not drop it or subject it to impact, or it might be damaged.

■ Mounting

● Installation locations

Avoid mounting the device in the following locations:

- Locations subject to high and low temperature and humidity
- Locations whose atmospheres contain large amounts of dirt and dust, salt, conductive substances such as iron powder, water droplet, oil mist or organic solvents
- Locations subject to direct sunlight and rain
- Locations directly subject to mechanical vibration or shock
- Locations close to sources of electrical noise
- Locations where strong magnetic or electrical fields are generated

! Handling Precautions

- The valve of this device cannot completely shut a flow off. If complete shutoff is required, provide a shutoff valve separately.

● Changing the display direction (models with integrated display only)

The display can be turned 180°, in case the controller has been mounted with the display upside-down.

- Procedure
 - (1) Turn the power OFF.
 - (2) Remove the four screws holding the display.
 - (3) Lift up the display from the body, and turn it 180° counterclockwise.

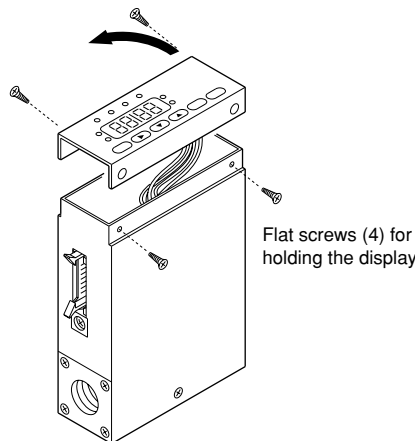

- (4) Put the display back on the body, and fasten with the four screws taken off in step (2).
- (5) To return the display to its original position on the body, turn it 180° clockwise.

! Handling Precautions

- Before changing the display direction, be sure to turn the power OFF.
- Prevent foreign objects from falling inside the body when the display is taken off. Failure to do so might cause trouble or malfunction.
- Do not remove the connectors used inside the device.

● **Installing joints (UNF) connections**

! CAUTION	
!	When installing joints (UNF connections), secure the lower part of the body in a vise or the like gripped between rags to protect the finished surfaces, and turn the joint to tighten. The device may be damaged if the lower body is not secured.

When using a standard type UNF connection, install the joint first (except when the pipe is directly connected).

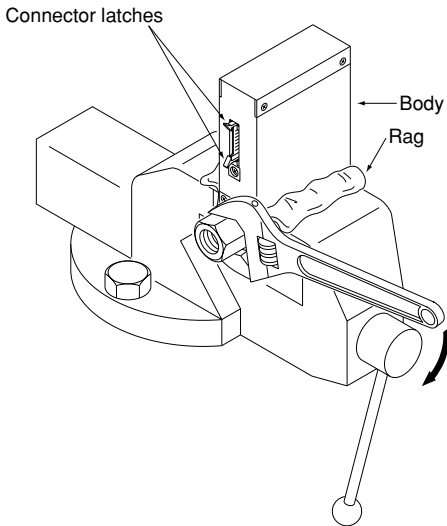

! Handling Precautions

- Do not hold the top part of the body with your hand. Doing so might deform the case.

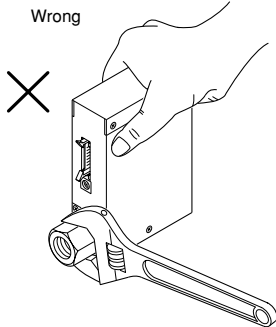

- Take special care not to damage the connector latches.

● Installation procedure

⚠ CAUTION



Mount securely in order to prevent vibration. Otherwise, equipment failure could result.



Mount the device horizontally. Do not mount it with the display facing down. Doing so might cause measurement error or equipment failure.

- MQV9200/9500/0002/0005/0020/0050

Install the device with two M4 screws using the mounting holes on the base of the device.

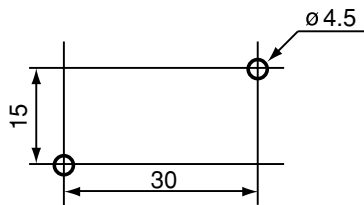

- MQV0050(J, K)/0200/0500

Install the device with four M4 screws using the mounting holes on the base of the device.

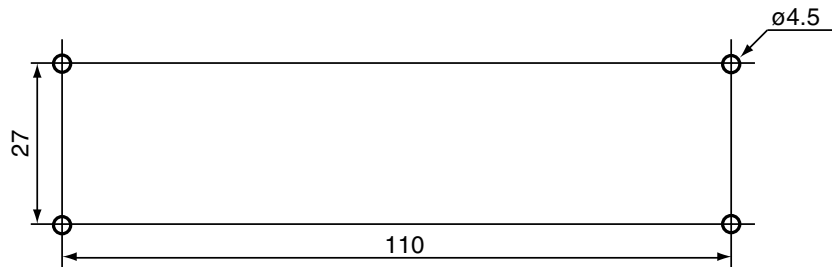

● Installing the separate display unit

For models with a separate display

- (1) Make mounting holes in the panel according to the panel cutout dimensions.

Panel cutout dimensions

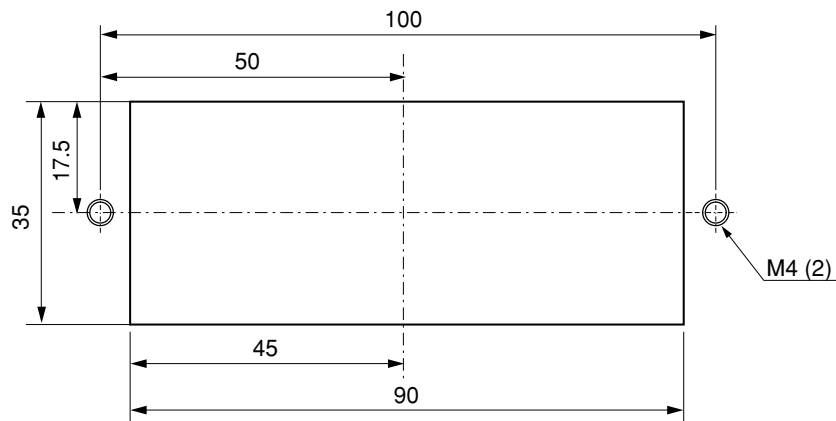

- (2) Mount the display and secure it by tightening the screws.

● Installing the front cover for the separate display unit

For models with a separate display, a front cover (decorative frame) can be mounted. Use of this cover makes it possible to hide the mounting screws, improving the appearance.

Items needed for installation

- Front cover (81446858-001), 1 set
- Phillips screwdriver

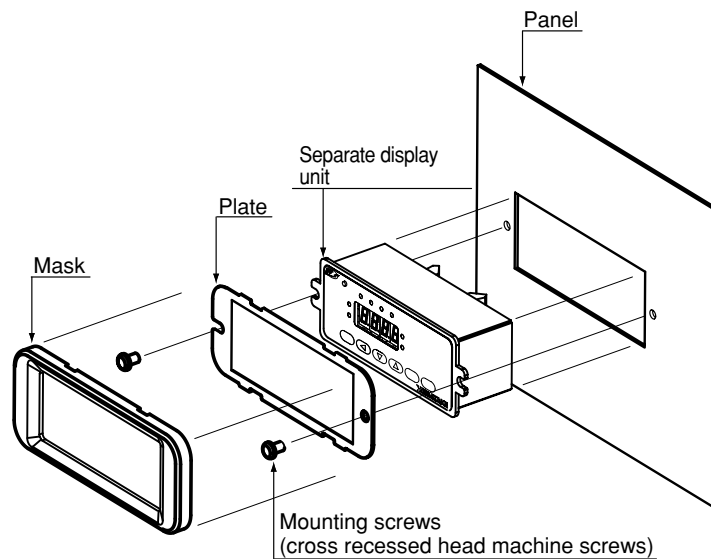
**Note**

- The front cover set includes one mask, one plate, and two mounting screws.

Procedure

- (1) As shown in the figure, put the plate over the display panel, and then secure it to the display by tightening the screws.
- (2) Fit the mask onto the display to mount it.

■ Piping

⚠ CAUTION

- ❗ Mount this device horizontally. However, do not mount with the display facing down. Doing so might cause measurement error or device failure.
- ❗ For the MQV0050(J, K)/0200(J, K)/0500(J, K), use the largest pipe possible in order to reduce pressure loss in the pipes, and do not install any equipment near the MQV that can cause a large pressure loss. If there is a large pressure loss in the pipes or equipment, the pressure of the gas supply to this device (operation differential pressure) will be affected and will fluctuate greatly with the flow rate. This could result in unstable control.
- ❗ When making the pipe connections, hold the hexagonal part of the connector section and turn the pipe to tighten. After connecting, check that there are no gas leaks.
- ❗ If using Rc connections, take care not to coat with too much sealant. Foreign matter or burrs in the pipes may also cause measurement errors.

ⓘ Handling Precautions

- Make sure that the gas flows into the device in the direction indicated by the FLOW arrow on the body. Otherwise, the flow rate cannot be controlled correctly.
- Do not touch the pipe sections of a controller treated to be oil-free with your bare hands. Doing so will degrade the oil-free treatment.
- Do not hold the top part of the body with your hand when connecting piping. Doing so might deform the case.

Fasten and connect pipes to the body using a wrench (spanner) or similar tool on the hexagonal sections of the joints.

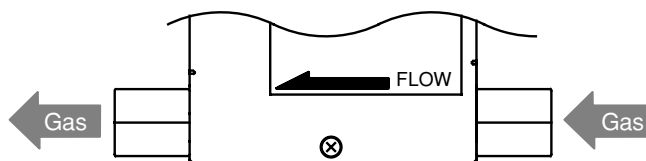

● Coating sealant (Rc connection)

ⓘ Handling Precautions

- Coat with an appropriate amount of sealant. Do not coat the top two threads. Remove any dirt or burrs from inside the pipes.

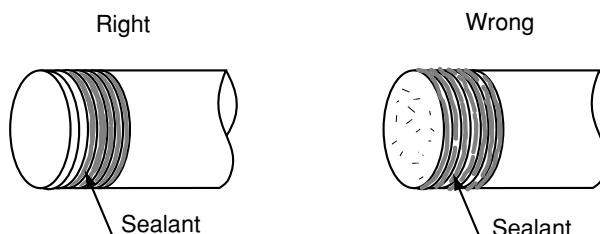

■ Wiring

CAUTION	
	Do not apply a negative voltage or a voltage exceeding 5V to the external setup voltage input terminal. Doing so might cause malfunction or equipment failure.
	When using a relay for external contact input and/or external 3-way switching input, always use a relay designed for micro-current use (with gold contacts). Failure to do so could cause faulty contact, resulting in malfunction.
	If there is a risk of a power surge caused by lightning, use a surge protector to prevent fire or equipment failure.
	Gas type switching by external contact input, flow rate switching, and analog input/output voltage range switching by external 3-way input switching should be done only after setting the operation mode to fully closed. Switching while controlling could cause large fluctuations.
	Be sure to check that the wiring is correct before turning the power on. Incorrect wiring could cause damage or malfunction.

● Connector pin layout

Connector model No. (device side): HIF3BA-20PA-2.54DS
 Manufacturer: HIROSE ELECTRIC CO., LTD.

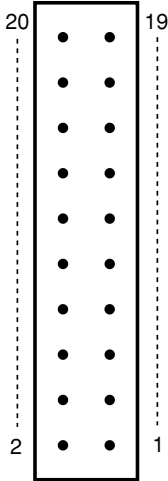

View from connector insertion side

● Table of compatible connectors (all made by HIROSE ELECTRIC CO., LTD.)

Connector type	Compatible connector model No.	Compatible contact model No.	Compatible wire
Contact crimp type	HIF3BA-20D-2.54C	HIF3-2226SCC	AWG#22 to #26 (single wire allowed)
Cable clamp type	HIF3BA-20D-2.54R	Not required	AWG#28 (flat cable only)

● Connector signal names

Pin number	Signal name	Description	Remarks
20	+5V (5mA max.)	5Vdc reference voltage output	5mA max.
19	FLOW OUT	Instantaneous flow rate (PV) or flow rate setpoint (SP) output	0 to 5V/1 to 5V/0 to 20mA/ 4 to 20mA output
18	A.GND	Analog ground	Analog signal common
17	FLOW SP INPUT	Setpoint flow rate (SP) voltage input	0 to 5V/1 to 5V/0 to 20mA/ 4 to 20mA input
16	MODE INPUT	External 3-way switching input	3-stage switching input (OPEN/GND/5V)
15	DI3	External contact input 3	2-stage switching input (OPEN/GND)
14	DI2	External contact input 2	
13	DI1	External contact input 1	
12	EV2 OUT	Event output 2	Open collector non-insulated output
11	EV1 OUT	Event output 1	
10	ALM OUT	Alarm output	
9	D.GND	Digital ground	Digital signal common
8	DB	RS-485 communications DB	Do not connect on models without the communications function.
7	DA	RS-485 communications DA	
6	D.GND	Digital ground	Digital signal common
5	TEST	For test	Do not use.
4	POWER GND	Power supply ground	Connect two wires each in parallel to the power supply to reduce voltage drop caused by wiring resistance.
3	POWER GND	Power supply ground	
2	POWER (24V)	Power supply + (24Vdc)	
1	POWER (24V)	Power supply + (24Vdc)	

● Wiring

- Power supply

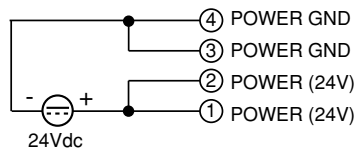

- RS-485 communications (for models with optional RS-485 only)

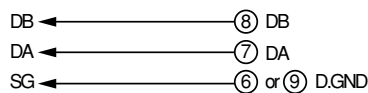

- Alarm output/event output

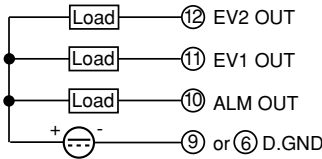

! Handling Precautions

- Take special care that the event and alarm outputs do not exceed the output rating of the device. Additionally, when driving a relay, use an appropriate coil surge absorption diode built-in relay. Failure to do so might cause the device to malfunction.

- External contact input

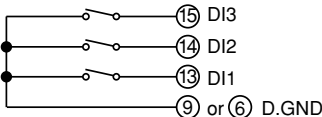

! Handling Precautions

- When switching by relay contact, use an appropriate relay intended for micro-current use (with gold contacts). Failure to do so could cause faulty contact, resulting in malfunction.

- Analog I/O

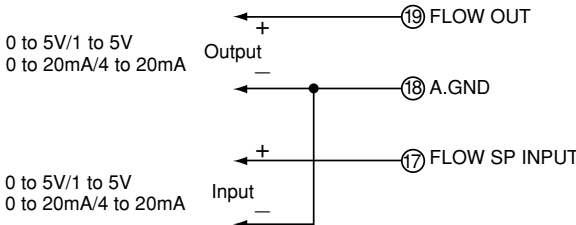

- When using potentiometer (0 to 5V)

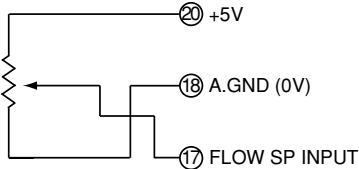

- External 3-way switching input

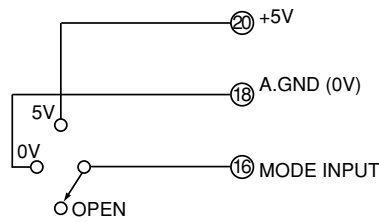

! Handling Precautions

- When switching by relay, use an appropriate relay intended for micro-current use (with gold contacts). Failure to do so could cause faulty contact, resulting in malfunction.

Operation of external 3-way switching input

Input state of pin No.16		OPEN	GND	5V
Assigned function				
Switching of operating mode 1		Control	Fully closed	Fully open
Switching of operating mode 2		Fully closed	Control	Fully open
Switching of SP No.		SP-0	SP-1	SP-2
Switching of totalizing operation		Continue counting	Reset	Stop counting
Switching of analog I/O voltage range	Input	Internal reference* 0 to 5V or external reference 0 to 20mA	External reference 0 to 5V or 0 to 20mA	External reference 1 to 5V or 4 to 20mA
	Output	0 to 5V/0 to 20mA	0 to 5V/0 to 20mA	1 to 5V/4 to 20mA

* "Internal reference" refers to the use of the 5Vdc reference voltage pin (No. 20) on this device, and is used when the setting value is set by an externally connected potentiometer.

📖 Note

- For details on how to assign external 3-way switching input functions, see Chapter 5, ADVANCED OPERATION.

● Example of wiring

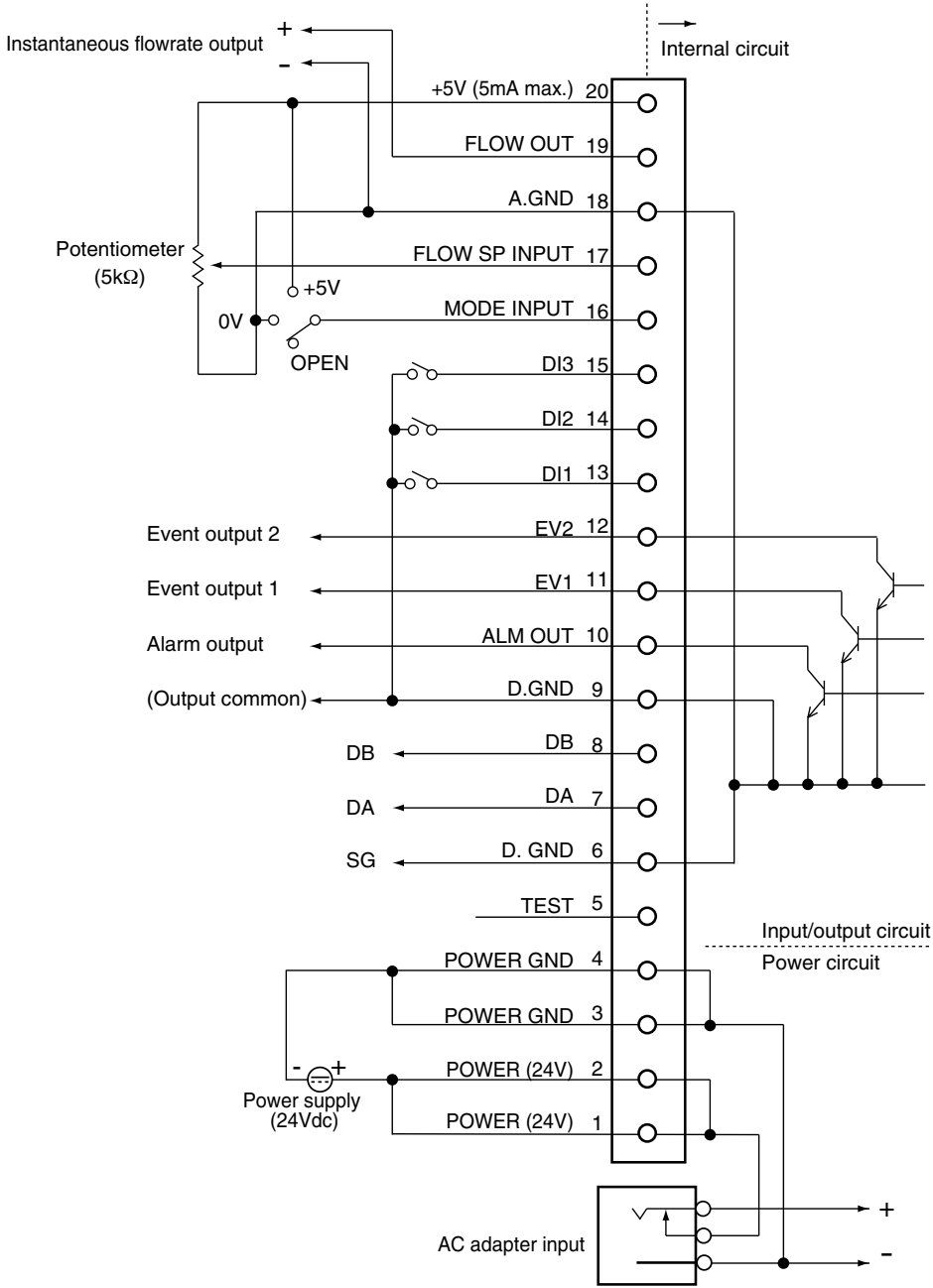

! Handling Precautions

- Do not input any signal to pin No. 5.
- The power circuit is isolated from the input/output circuit inside this device.
- Even though the analog GND and digital GND are connected internally, always carry out the grounding wiring individually.
- When the AC adapter plug is inserted into the AC adapter power supply terminal, the power supply changes from the DC power supply to the AC adapter.
- The former AC adapter 81446682-001 (15Vdc, 350mA) cannot be used with this MQV.

● Connector terminal block

Sometimes two or more connections must be made to the same pin during wiring. In this case, use a connector terminal block. If you need a 20-core cable for the connectors on the device and connector terminal block, contact the azbil Group or your dealer.

 **Note**

- Recommended connector terminal block
 Manufacturer: Toyo Giken
 Model: PCN-1H-20
 Mounting connector
 HIROSE ELECTRIC CO., LTD., HIF3BA-20PA-2.54DSA
 Compatible connector (other side)
 HIROSE ELECTRIC CO., LTD., HIF3BA-20D-2.54R

 **Handling Precautions**

- For details regarding the cable with connector on both ends, contact the azbil Group. (The optional dedicated connector, 81446681-001 or 81446951-001, cannot be used to connect to the connector terminal block.)
- The specifications of the recommended connector terminal block are subject to change. Contact the manufacturer beforehand for details.

This terminal block can be mounted directly on a DIN rail.

Pin No.	Terminal block No.
20	B-10
19	A-10
18	B-9
17	A-9
16	B-8
15	A-8
14	B-7
13	A-7
12	B-6
11	A-6
10	B-5
9	A-5
8	B-4
7	A-4
6	B-3
5	A-3
4	B-2
3	A-2
2	B-1
1	A-1

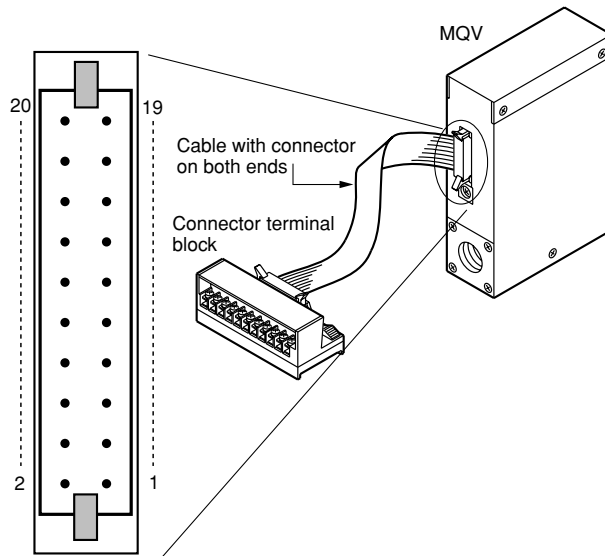

The following table shows the correspondence between connector pin Nos. and terminal block Nos:

Chapter 4. BASIC OPERATION

4 - 1 Switching Displays

CAUTION



Do not operate the console keys using a sharp object such as a mechanical pencil or screwdriver. Doing so might damage the console.

■ Basic operation

Basic operation is used to change the display to instantaneous flow rate (PV), flow set value (SP), totalized flow value, or valve amperage.

Normally, when the power is turned ON, the instantaneous flow rate is displayed in basic operation mode. When this is the case, operating the DISP key changes the contents of the 7-segment display as described below.

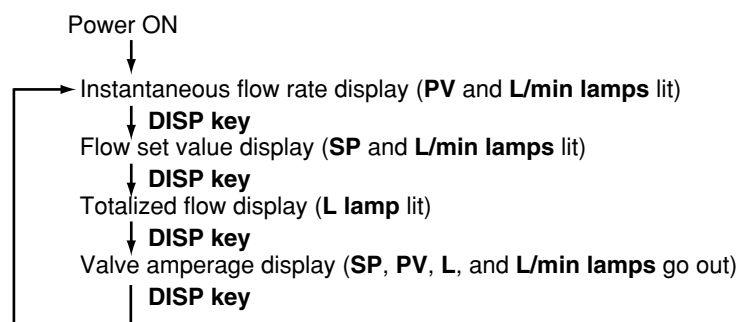

Handling Precautions

- If there is no operator input for approximately 10 seconds while the flow set value is being displayed, the display automatically reverts to the instantaneous flow rate display.
- On the MQV9005/9020/9200, the mL/min lamp replaces the L/min lamp. On the MQV9005/9020, the mL lamp replaces the L lamp, and on the MQV0050(J, K)/0200/0500, the m³ lamp replaces the L lamp.

● Indicating instantaneous flow rate (PV display)

When the power is turned ON, the PV and L/min lamps light, and the instantaneous flow rate is indicated on the display.

Handling Precautions

- When the operating mode is set to fully closed, and the flow rate is zero, and when the operating mode is switched to the control mode or fully open mode, the operating mode (*OFF/ON/FULL*) is displayed for about one second.
- When an alarm occurs, the alarm code and the PV are displayed alternately.

● Indicating the flow set value (SP display)

If DISP key is pressed while the instantaneous flow rate is displayed, the PV lamp goes out, the SP lamp lights and the flow set value (SP) is indicated on the display.

Handling Precautions

- If the SP value is not changed for about 10 seconds while the flow set value is displayed, the instantaneous flow rate is redisplayed automatically. For details on how to change the flow rate, see section 4-2, Setting the Flow Rate (page 4-4).
- When multiple setpoints (2 to 8 SPs) have been selected in $\zeta-04$ in the function setup, when switching by external input, the flow set value (SP value) is displayed for about one second, and then the display switches to the SP No.

● Indicating the totalized flow

When the DISP key is pressed while the flow set value (SP) is displayed, the SP and L/min lamps go out, the L lamp lights up, and the totalized flow value is indicated on the display.

When the totalized flow value is 10,000 or higher, the number is displayed in two parts, the last four digits, followed by the first four digits. When the value is the last four digits, the decimal point on the display is lit up.

For example, when the totalized flow value is "123,456L", "3456." is displayed. Press the DISP key to display " 12". To alternately display the first and last four digits, press the ◀ key.

Handling Precautions

- When an alarm occurs, the alarm code and the totalized flow value are displayed alternately.

● Resetting the totalized flow count

The totalized flow value is reset to zero by holding down the ENT key for two seconds or more while the totalized flow value is displayed.

Note (Advanced operation)

- Totalized flow event output function
When "1: Totalized flow rate count up ON" is selected as the event output type for function setup $\zeta-07$ or $\zeta-08$, the event output turns ON when the totalized flow value reaches the totalized flow event setting. This threshold value for the totalized flow event is set in the parameter setup mode.
- Totalized flow event automatic valve shut-off function
When "1: Function enabled" is set for the automatic valve shut-off function in function setup $\zeta-13$, the valve will be automatically closed fully if the totalized flow value reaches the preset value.
The threshold value for the totalized flow event is set in the parameter setup mode.
For details on function setup and parameter setup, see Chapter 5, ADVANCED OPERATION.

- **Valve amperage display**

If DISP key is pressed while the totalized flow is displayed, the PV, SP, L and L/min lamps go out, and the electrical current to the valve (0.0 to 100.0 [%]) is indicated on the 7-segment display.

**Note (Advanced operation)**

- When "1: Only upper limit alarm used," "2: Only lower limit alarm used," or "3: Upper and lower limit alarm used" is selected for valve amperage alarm type (1-20 in the function setup), the valve amperage alarm will be activated if the valve current exceeds the upper limit set value or goes below the lower limit value. The valve amperage upper and lower limits are set in the parameter setup mode.

For details on function setup and parameter setup, see Chapter 5, ADVANCED OPERATION.

**Handling Precautions**

- The valve amperage can vary greatly according to the differential pressure even at the same flow rate. The valve amperage alarm function cannot be used unless the differential pressure is stable.
- Even under stable differential pressure conditions, the relationship between the valve amperage and flow rate has hysteresis characteristics (amperage may vary even at the same flow rate).

When using the valve amperage alarm, be sure to test sufficiently under operating conditions. That way, an appropriate alarm current setting can be determined.

4 - 2 Setting the Flow Rate

Set the flow rate as shown below.

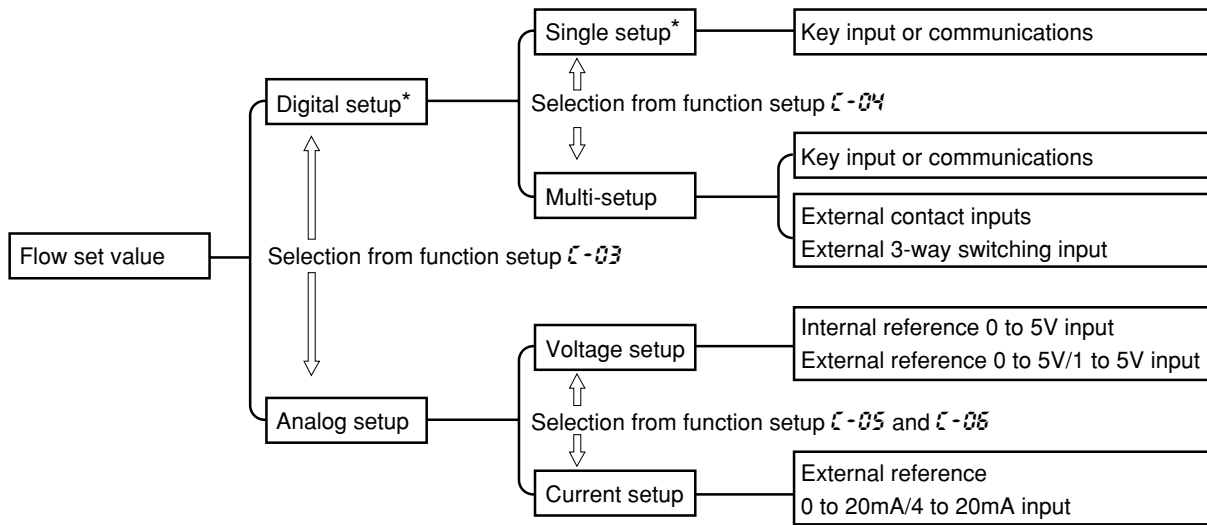

* Factory setting

Two kinds of setup methods, that is, digital and analog setup, are provided to set the flow rate. Additionally, the digital setup further provides two kinds of setup methods, single setup and multi-setup.

In single setup, the flow rate is set through key input or communications. In multi-setup, the flow rate is set through the key input, communications, external contact input, or external 3-way switching input. One flow set value can be set in the single setup while up to eight flow set values can be set in the multi-setup.

In the analog setup, the flow rate is set through the external voltage/current input. The factory setting is digital setup.

Either digital setup or analog setup is selected as the flow rate setup method (㉔-03 in the function setup).

0: Digital setup (flow rate is set through the key input or communication.)

1: Analog setup (flow rate is set through the external analog voltage/current.)

For further detailed setup, make selections in ㉔-04 to ㉔-06 in the function setup. For details on function setup, see Chapter 5, ADVANCED OPERATION.

! Handling Precautions

- Setup by communications is available only for models with RS-485 communications.

■ Digital flow rate setup

Up to eight SP values can be set on this device. The operating procedure may vary depending on the number of SP values to be set.

● Single setup (number of SPs in function setup $\zeta-04$ is 1)

Follow the procedure below to change the SP value:

(1) Press the DISP key.

>>The SP (flow rate setpoint) is shown on the 7-segment display

(2) Change the SP value by pressing the ▲ or ▼ keys. You can move to the digit to be changed by pressing the ◀ key.

>>The digit currently being changed starts blinking.

(3) When you have reached the target value, press the ENT key.

>>The SP value is set, and saved.



Note (Advanced use, direct setup function)

Control can be executed using an SP value currently being changed (indicated by blinking display) when the direct setup function is enabled for the instantaneous flow rate direct setup function ON/OFF ($\zeta-21$ in the function setup). In this case, the ENT key need not be pressed to enter the SP value.



Handling Precautions

- When switching the display by pressing the DISP key, first press the ENT key to enter the SP value, and switch the display.

For details on how to set up functions, see Chapter 5, ADVANCED OPERATION.

● Multi-setup (number of SPs in function setup $\zeta-04$ is 2 to 8)

In multi-setup, up to eight SP values can be switched by key operation and by external contact input.

Follow the procedure below to change the SP No. and SP value:

(1) Press the DISP key.

>>The display switches to SP No. $SP-0$ to $SP-7$ after about one second.

(2) Press the ▲ or ▼ keys to change the SP No. and press the ENT key.

>>The SP No. is entered.

(3) Change the SP value by pressing the ▲ or ▼ keys. You can move to the digit to be changed by pressing the ◀ key.

>>The digit currently being changed blinks while the SP value is being changed.

(4) When you have reached the target value, press the ENT key to enter the new SP value.

>>The SP value and SP No. are updated, and the SP value of the selected SP No. is now the active SP.

 **Note (Advanced use, direct setup function)**

Control can be executed using an SP No. or SP value currently being changed (indicated by blinking display) when the direct setup function is enabled for the instantaneous flow rate direct setup function ON/OFF (☒ - ☒ ! in the function setup). In this case, the ENT key need not be pressed to enter the SP value.

 **Handling Precautions**

- When switching the display by pressing the DISP key, first press the ENT key to enter the SP value.

For details on how to set up functions, see Chapter 5, ADVANCED OPERATION.

 **Handling Precautions (Common to single setup and multi-setup)**

- When "1: Analog setup" is selected as the flow rate setup method (☒ - ☒ in the function setup) and the SP value is controlled by external voltage input, the SP value and SP No. cannot be changed with the ▲ or ▼ key.
- If no operation is made for approximately 10s after the operation stated in (1) has been performed, the display automatically returns to the instantaneous flow rate display.
- If the DISP key is pressed during the operations in steps (2) and (3) (setting is blinking), the SP No. and SP value return to their previous values without saving of new values.
- When the SP value is updated in step (3) for single setup or in step (4) for multi-setup, the display automatically returns to the instantaneous flow rate display after approximately 2s have elapsed.

■ Flow rate setup by external contact input (Advanced use)

When assigning "3: Switching of SP No." at external contact input function assignment $\zeta-10$ to $\zeta-12$ in the function setup, up to eight SP values can be changed by means of external contact ON and OFF combinations.

(1) When the number of preset SP values is set to 5 to 8 in function setup $\zeta-04$.

Assign "3: Switching of SP No." to all of $\zeta-10$ to $\zeta-12$ in the function setup.

	Input 3 (DI3)	Input 2(DI2)	Input 1(DI1)	Selected SP
External contact input state	OFF	OFF	OFF	SP-0
	OFF	OFF	ON	SP-1
	OFF	ON	OFF	SP-2
	OFF	ON	ON	SP-3
	ON	OFF	OFF	SP-4
	ON	OFF	ON	SP-5
	ON	ON	OFF	SP-6
	ON	ON	ON	SP-7

(2) When the number of SP values is set to 3 or 4 in function setup $\zeta-04$.

Assign "3: Switching of SP No." to two of $\zeta-10$ to $\zeta-12$ in the function setup.

	External contact input pair		Selected SP
	Input 2 (DI2)	Input 1 (DI1)	
	Input 3 (DI3)	Input 1 (DI1)	
	Input 3 (DI3)	Input 2 (DI2)	
External contact input state	OFF	OFF	SP-0
	OFF	ON	SP-1
	ON	OFF	SP-2
	ON	ON	SP-3

(3) When the number of SP values is set to 2 in function setup $\zeta-04$.

Assign "3: Switching of SP No." to one of $\zeta-10$ to $\zeta-12$ in the function setup.

	Input 1 to 3 (DI1 to DI3)	Selected SP
External contact input state	OFF	SP-0
	ON	SP-1

! Handling Precautions

- When changing the SP number by external contact input, the ▲ and ▼ keys cannot be used (but the SP value can be changed).

■ Flow rate setup by external 3-way switching input (Advanced use)

When "2: Switching of SP No." is assigned at external 3-way switching function F-09 in the function setup, three SP values (SP-0 to SP-2) can be changed with the external 3-way switching input as described in the table below.

External 3-way switching input state	Selected SP
OPEN	SP-0
0V	SP-1
5V	SP-2

! Handling Precautions

- When the SP No. is switched by the external 3-way switching input, you cannot switch the SP No. using ▲ or ▼ keys, though you can switch the SP value.

■ Analog flow rate setup

The SP value (flow set value) can be changed by analog voltage by selecting analog setting as the flow rate setting method in function setup $\zeta-03$. For details on how to set up the function, see Chapter 5, ADVANCED OPERATION.

The setup voltage/current range can be selected in the input range selection for analog setup ($\zeta-05$ in the function setup).

The selection of voltage input/current input is linked automatically with the settings for analog output type and range selection ($\zeta-06$ in the function setup). For example, when current output is selected as analog output type and range selection in $\zeta-06$, the input type becomes current input type. Then, analog setup voltage/current for SP value can be calculated by the equations below.

Function setup $\zeta-05$	Input voltage/current range	Setup voltage/current equation
0	Internal reference 0 to 5V*/ External reference 0 to 20mA	Setup voltage [V] = Setting flow rate \div Full-scale flow rate \times Reference output voltage Setup current [mA] = Setting flow rate \div Full-scale flow rate \times 20
1	External reference 0 to 5V/ External reference 0 to 20mA	Setup voltage [V] = Setting flow rate \div Full-scale flow rate \times 5 Setup current [mA] = Setting flow rate \div Full-scale flow rate \times 20
2	External reference 1 to 5V/ External reference 4 to 20mA	Setup voltage [V] = Setting flow rate \div Full-scale flow rate \times 4 + 1 Setup current [mA] = Setting flow rate \div Full-scale flow rate \times 16 + 4

* Internal reference 0 to 5V input means that the 5V-reference voltage input of connector pin No. 20 of this controller is used and a voltage is input with the optional potentiometer (variable resistor with dial). In this case, no external power supply for setup is needed. The reference voltage (5V) is not accurate, so to actually measure and calculate the reference voltage output from this controller, use a voltage tester for the setup voltage calculation.

Note (Advanced use)

When "1: Function enabled" is selected for analog optional scaling function $\zeta-28$ in the function setup, the full scale flow rate can be changed to a desired level during analog setup. In this case, the full-scale flow rate of the analog flow rate output voltage/current (PV output voltage/current) is also changed as it is linked with the above flow rate. The scaling flow rate is set in the parameter setup mode.

For details on how to set up functions, see Chapter 5, ADVANCED OPERATION.

4 - 3 Selecting the Operating Mode

■ Operating mode selection

Three kinds of valve operating modes are provided, "control mode," "fully closed mode," and "fully open mode."

The factory setting is the control mode. The operating mode can be forcibly changed to "fully closed mode" (valve is fully closed) or "fully open mode" (valve is fully open).

As shown in the diagram below, the mode is changed alternately between the control mode and fully closed mode every time the RUN key is pressed.

Additionally, to change the mode from the control mode to the fully open mode, keep the RUN key pressed for 2 seconds or longer.

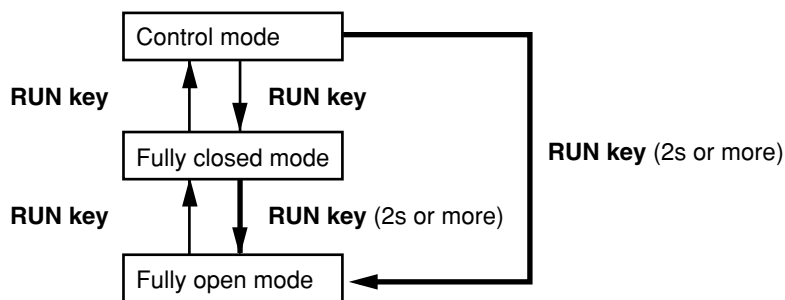

■ Operating mode display

The operating mode is shown on the 7-segment display during instantaneous flow rate display. Additionally, the OK lamp blinks in the fully open mode.

Operation mode	7-segment display	OK lamp	Remarks
Fully closed mode	oFF	Out	oFF is always displayed after checking that the flow rate is zero (0).
Control mode	on	Out or lit	on is displayed for approximately 1 second when the mode changes to the control mode.
Fully open mode	FULL	Blinking	FULL is displayed for approximately 1 second when the mode transits to the fully open mode.

Note (Advanced use, Selecting the operating mode through external input)

- When "operating mode change (5, 6, or 8)" is selected for external contact input function assignment $\xi - 10$ to $\xi - 12$ in the function setup, the operating mode can be changed through external contact input.
- When "operating mode change (1, or 5)" is selected for external 3-way switching input function assignment $\xi - 09$ in the function setup, the operating mode can be changed through the external 3-way switching input.

For details on how to set up functions, see Chapter 5, ADVANCED OPERATION.

Handling Precautions

- When "0: RUN key disabled" is selected for "┘-02: RUN key operation and operating mode selection when power turned ON" in the function setup, the operating mode is not changed even though the RUN key is pressed.
- When "operating mode change (5, 6, or 8)" is selected for external contact input function assignment ┘-10 to ┘-12 in the function setup, changes by external contact take precedence over RUN key operation. In the same manner, when "operating mode change (1 or 5)" is selected for external 3-way switching function ┘-09 in the function setup, the external 3-way switching input takes precedence over the RUN key operation.
- The fully open mode cannot directly be changed to the control mode. To make the change, press the RUN key to change the fully open mode to the fully closed mode. After that, press the RUN key again to change the fully closed mode to the control mode.

Chapter 5. ADVANCED OPERATION

The advanced operation provides three kinds of modes, "Function setup mode," "Parameter setup mode," and "Controller information display mode."

■ Setup mode transition operation

Normally, when the power is turned ON, the instantaneous flow rate is displayed in the basic operation mode.

When keys are operated as described in the diagram below during instantaneous flow rate display, the operation changes to the specified mode.

When the operating mode changes to "Function setup mode" or "Parameter setup mode," the specified setup can be changed.

In the "Device information display mode," you can check the statuses of major setup items (gas type, full scale flow rate, reference temperature, and communications address).

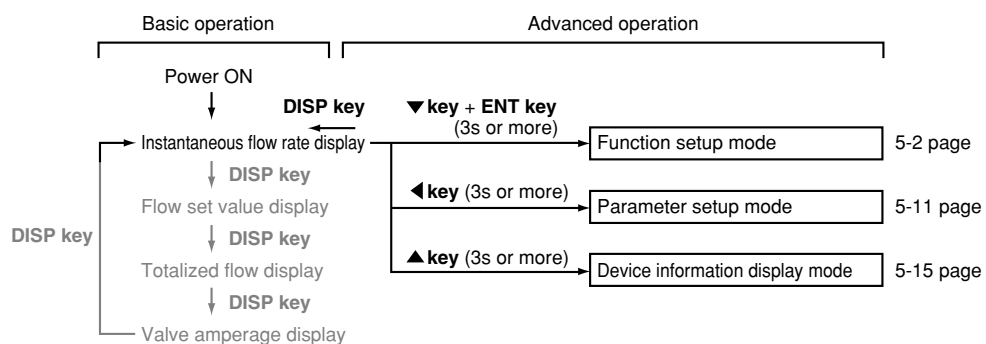

5 - 1 Functions

This section describes how to set up functions.

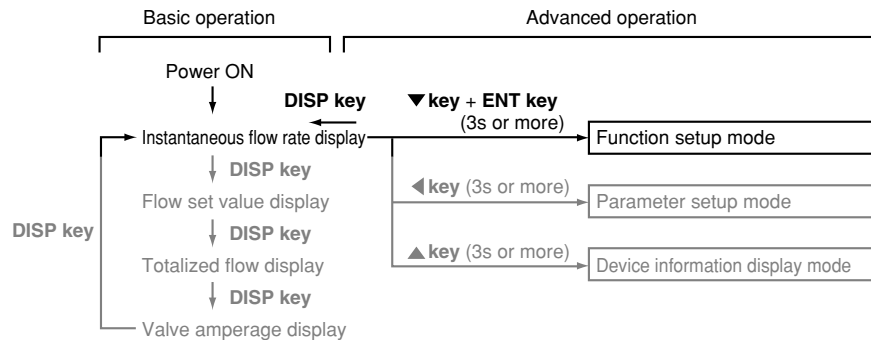

■ Setup method

Follow the procedure below to set functions such as event output type and external contact input assignments:

- (1) Press the **DISP** key several times to display the instantaneous flow rate.
>>The PV and L/min lamps light (mL/min in MQV9005/9020/9200).
- (2) Hold down the **▼** and the **ENT** keys for three seconds or more.
>>Item $\xi-01$ is displayed on the 7-segment display and mode changes to the function setup mode.
- (3) Press the **▲** or **▼** key to select the desired setup item number, and then press the **ENT** key.
>>The current setting value blinks on the 7-segment display.
- (4) Press the **▲** or **▼** key to select the desired setting.
- (5) When you have selected the desired setting, press the **ENT** key to enter the setting.
>>The setting value is updated. (At this point, the setting value is saved.)
- (6) If you want to set up other items, return to step (3) and repeat the procedure. Otherwise, proceed to step (7).
- (7) Press the **DISP** key.
>>The function setup mode changes to the instantaneous flow rate display.

! Handling Precautions



- If you do not press any keys for one minute after entering the function setup mode, the display automatically returns to the instantaneous flow rate display.
- If you press the **DISP** key without pressing the **ENT** key after carrying out the operation in step (4), the setting remains at the previous value without being updated.

■ Function setup items

The following table shows the function setup items:

Display Item	Item Description	Setup Item and Description	Factory Setting	Remarks
└-01	Key lock	0: Key lock disabled 1: Settings other than flow rate setting (SP) are key-locked 2: All settings are key-locked	0	The key lock can be cancelled even while it is enabled. When an attempt is made to change a key-locked setting, LoL is indicated on the display.
└-02	RUN key operation and operation mode selection when power turned ON	0: RUN key disabled (Operation starts in the control mode when the power is turned ON) 1: RUN key enabled (1) (Operation is started up in the operating mode used before power shut-down when the power is turned ON) 2: RUN key enabled (2) (Operation is started up in the fully closed mode when the power is turned ON)	1	Determines whether or not the operating mode is changed (fully closed/control/fully open) by the RUN key. Additionally, the operating mode at power ON can be selected. For how to select the operating mode: 4-3 Selecting the Operating Mode (page 4-10).
└-03 *1	Flow rate setup method (SP setup method selection)	0: Digital setup (set by key operation or communications) 1: Analog setup (set by external analog input voltage)	0	
└-04	Number of flow set value (number of SPs selection)	0: Number of SPs = 1 (SP-0 only) 1: Number of SPs = 2 (SP-0, SP-1) 2: Number of SPs = 3 (SP-0 to SP-2) 3: Number of SPs = 4 (SP-0 to SP-3) 4: Number of SPs = 5 (SP-0 to SP-4) 5: Number of SPs = 6 (SP-0 to SP-5) 6: Number of SPs = 7 (SP-0 to SP-6) 7: Number of SPs = 8 (SP-0 to SP-7)	0	How to switch the SP number using external contact input and external 3-way switching input: Multi-setup (page 4-5).
└-05 *2, *3	Input range selection of analog setup (analog SP input range selection)	(1) Analog output selection is set at voltage output (└-05 = 0, 1, 4, or 5). 0: 0 to 5V internal reference input 1: 0 to 5V external reference input 2: 1 to 5V external reference input (2) Analog output selection is set at current output (└-05 = 2, 3, 6, or 7) 0: 0 to 20mA external reference input 1: 0 to 20mA external reference input 2: 4 to 20mA external reference input	0	Internal reference 0 to 5V input is the setting to use the 5V-reference voltage from this device when inputting a voltage with the optional potentiometer (variable change resistor with dial). Using this method, no external power supply for setup is needed. The voltage input/current input is automatically selected as it is linked with the set value of └-05: Table in Note *2 (page 5-9).

Display Item	Item Description	Setup Item and Description	Factory Setting	Remarks
<p>└-06 *2, *3</p>	Analog output type and range selection	<p>0: 0 to 5V instantaneous flow rate output 1: 1 to 5V instantaneous flow rate output 2: 0 to 20mA instantaneous flow rate output 3: 4 to 20mA instantaneous flow rate output 4: 0 to 5V setting flow rate output 5: 1 to 5V setting flow rate output 6: 0 to 20mA setting flow rate output 7: 4 to 20mA setting flow rate output</p>	0	The scale can also be changed to the desired flow rate range. For details, see └-28 (Optional analog scaling function).
└-07	Event output 1 type assignment	<p>0: Not used (OFF at all times) 1: ON when the totalized flow event occurs 2: Totalized pulse output 3: ON when the flow rate is OK 4: ON in control mode 5: ON in fully open mode 6: ON in control or fully open mode 7: ON in fully closed mode 8: PV upper limit event 9: PV lower limit event 1 10: PV lower limit event 2 -1 to -10: Inverse output of above 1 to 10 (Normal operation: ON, Event occurrence: OFF)</p>	0	<p>The event output delay time is set in the parameter setup mode (see page 5-11). Note, however, that delay cannot be set for totalizer pulse output. 9: Events are output even in fully closed operation mode. 10: Events are not output in fully closed operation mode. -1 to -10: OFF at all times during power shutoff</p>
└-08	Event output 2 type assignment		0	
└-09	External 3-way switching function	<p>0: Not used 1: Switching of operating mode 1 2: Switching of SP No. 3: Switching of totalizing operation 4: Switching of analog I/O voltage range (simultaneous external switching of └-05 and └-06) 5: Switching of operating mode 2</p>	0	<p>External inputs OPEN/GND/5V are switched as shown below. For details on wiring, see page 3-7.</p> <p>1: Control/fully closed/fully open 2: SP-0/SP-1/SP-2 3: Continue count/reset count/stop count 4: See the table in note *3 (page 5-10). 0 to 5V/0 to 5V/1 to 5V 5: Fully closed/control/fully open</p>

Display Item	Item Description	Setup Item and Description	Factory Setting	Remarks
$\zeta - 10$	External contact 1 input function assignment (2-way switching)	0: Not used 1: Reset totalized flow count 2: Stop totalizing flow count	0	3: For details on how to switch three or more SP Nos., see the description of the multi-setup (page 4-5).
$\zeta - 11$	External contact 2 input function assignment (2-way switching)	3: Switching of SP No. 4: Switching of instantaneous flow rate setup method 5: Valve forced fully closed 6: Valve forced fully open	0	4: The $\zeta - 03$ (analog/digital) setting is shown when the contact is ON. 7: "Slow start ON" must be selected in $\zeta - 17$ (Slow start when the contact is ON). Similarly, in case of SP ramp control, "SP ramp control 1 or 2" must be selected in $\zeta - 27$. (Ramp control when the contact is ON.)
$\zeta - 12$	External contact 3 input function assignment (2-way switching)	7: Switching of slow start operation or switching of instantaneous SP ramp control operation 8: Switching of operating mode (control by contact ON, forced fully closed by contact OFF) 9: Flow rate zero adjustment 10: Switching of gas type setup 11: Switching of flow rate range 12: Switching of SP ramp 13: Alarm reset	0	5, 6, 8: If the forced fully closed and fully open are input from two sources at the same time, both inputs become invalid. 9: Set the operation mode to full close or set the flow rate to zero and perform the contact ON operation for a minimum of 10 seconds. See page 6-2 for the details. 10: $\zeta - 18$ becomes active by contact OFF and $\zeta - 25$ becomes active by contact ON. 11: $\zeta - 24$ becomes active by contact OFF and $\zeta - 25$ becomes active by contact ON. 12: Parameter setup ramp 1 is selected when the contact is OFF. Ramp 2 is selected when the contact is ON. 13: All alarm detections are cancelled while the contact ON is being continued.
$\zeta - 13$	Automatic valve shut-off when the totalized flow event occurs	0: Function disabled 1: Function enabled	0	When the totalized flow count reaches the totalized flow event setting, the valve is closed fully. This totalized flow event preset value can be set in the parameter setup mode.  5-2 Parameters (page 5-11).
$\zeta - 14$	On/off of totalized flow reset function at start of control	0: Function disabled 1: Function enabled	0	When control is resumed from the fully closed operating mode, the totalized flow count is automatically reset.
$\zeta - 15$	Flow rate alarm setup type	0: Function disabled 1: Only upper limit alarm used 2: Only lower limit alarm used 3: Upper / lower limit alarm used	3	Set the alarm flow rate in the parameter setup mode.  5-2 Parameters (page 5-11).

Display Item	Item Description	Setup Item and Description	Factory Setting	Remarks
℄ - 15	Operation selection at alarm occurrence	0: Control continued and alarm output OFF any-time (alarm ignored) 1: Control continued and alarm output ON 2: Forced fully closed and alarm output ON 3: Forced fully open and alarm output ON -1: Control continued and alarm output ON -2: Forced fully closed and alarm output ON -3: Forced fully open and alarm output ON	1	Alarm code displays even if "0" is selected. -1 to -3: Output logic 1 to 3 is inverted (ON at all times). (However, they are turned OFF at all times during power shutoff.)
℄ - 17	Slow start setup	0: Slow start disabled 1 to 8: Slow start enabled (equivalent to approx. 1 to 6 seconds settling time)	0	Slow start is used when the external contact input turns ON when slow start operation switching is selected at ℄ - 10 to ℄ - 12.
℄ - 18	Gas type selection 1	0: Conversion factor for each gas type set by the user 1: Air, nitrogen. 2: Oxygen 3: Argon 4: Carbon dioxide (CO ₂) 5: Natural gas 13A (LNG) (Heating value: 46MJ/m ³) 6: 100% propane 7: 100% methane 8: 100% butane 11: Natural gas 13A (LNG) (Heating value: 45MJ/m ³)	(See Remarks)	An initial gas type is set at the factory. If the flow rate range changes due to a change in the gas type, the flow rate OK range and flow rate alarm range in the parameter setup must be changed. When "0" is selected, set the conversion factor (CF) in the parameter setup mode. ➡ 5-2 Parameters (page 5-11). If "10" is selected for any of ℄ - 10 to ℄ - 12 (external contact input function assignment) and only when an objective contact is turned ON, the gas type is the one selected by ℄ - 25 (gas type selection 2). 2: Selectable only on the oxygen model
℄ - 19	Temperature at reference conditions	0: 20°C, 1 atmosphere 1: 0°C, 1 atmosphere 2: 25°C, 1 atmosphere 3: 35°C, 1 atmosphere	0	
℄ - 20	Valve amperage alarm setup	0: Valve amperage alarm disabled 1: Only upper limit alarm enabled 2: Only lower limit alarm enabled 3: Upper / lower limit alarm enabled	0	Set up the alarm current value in the parameter setup. ➡ 5-2 Parameters (page 5-11).
℄ - 21	Direct setup function ON/OFF	0: Function disabled 1: Function enabled	0	SP value being changed (flashing) is used for control.

Display Item	Item Description	Setup Item and Description	Factory Setting	Remarks
ℓ - 22	Control dead zone setting	0: Function disabled 1: Function enabled	0	Valve operation stops while the control flow rate is within the OK judgment range. The OK judgment range can be set in the parameter setup mode. ☞ 5-2 Parameters (page 5-11).
ℓ - 23	PV filter (process for filtering of instantaneous flow-rate)	0: Without filter 1: Two samplings moving average 2: Four samplings moving average 3: Eight samplings moving average	0	If the PV filter is used at a "2" or "3" setting, the operational differential pressure must be lower than the standard differential pressure. Do not change the setting while control is in progress.
ℓ - 24	Flow rate range setup 1	0: Standard range 10 to 99: 10% to 99% of standard range. (When calculating the range reduction, the value is cut off at the least significant digit.) -10 to -99: 10% to 99% of standard range. (When calculating the range reduction, the value is not cut off at the least significant digit.)	0	The setup and display resolution levels can be improved by reducing the flow rate range. ☞ 5-4 Flow Rate Range Change Function and Settings and Display Resolutions After Change of Range (page 5-17) for details. If a value of 10 to 99 is set, the value is cut off at the least significant digit when calculating the range reduction. Example: Standard range = 30.0L/min. and range setup = 67 Calculation formula: $30.0 \times 0.67 = 20.1$ → Since the value is cut off at the least significant digit, the flow rate range becomes 20.0L/min. The range selected by ℓ - 25 becomes active if "11" is selected for assignments ℓ - 10 to ℓ - 12 (external contact input function assignment) and only when the objective contact is turned ON. However, the range selected by ℓ - 24 becomes active otherwise.
ℓ - 25	Flow rate range setup 2		0	
ℓ - 26	Gas type selection 2	0: Conversion factor for each gas type set by the user 1: Air, nitrogen 2: Oxygen 3: Argon 4: Carbon dioxide (CO ₂) 5: Natural gas 13A (LNG) (Heating value: 46MJ/m ³) 6: 100% propane 7: 100% methane 8: 100% butane 11: Natural gas 13A (LNG) (Heating value: 45MJ/m ³)	(See Remarks)	The gas type of the model number is factory set. This setting is valid only when "10: Switching of gas type setup" is selected at external contact input function assignment, for any of ℓ - 10 to ℓ - 12. See the Remarks column for ℓ - 10 to ℓ - 12 and ℓ - 18 for details.

Display Item	Item Description	Setup Item and Description	Factory Setting	Remarks
└- 27	SP ramp control function	0: Function disabled 1: SP ramp control 1. (In SP ramp-up: ramp 1, in SP ramp-down: ramp 2) 2: SP ramp control 2. (In external contact OFF: ramp 1, in external contact ON: ramp 2)	0	The SP change ramp level (the rate of change per second) can be set to a constant value for control startup and setting flow rate changed. Setting of ramps 1 and 2 is done in parameter setup mode. ☞ 5-2 Parameters (page 5-11) for details. In case of SP ramp control 2, the operation is performed by ramp 2 when "12" is selected in either one of └- 10 to └- 12 (external contact input function assignment) and also when the target contact is ON, but otherwise operation is performed by ramp 1. If "7" is selected anywhere in └- 10 to └- 12, SP ramp control is performed only when the target contact is ON.
└- 28	Optional analog scaling function	0: Function disabled 1: Function enabled	0	The flow rate at analog input / output 100% (5V) can be optionally set. The flow rate is set in parameter setup mode. ☞ 5-2 Parameters (page 5-11).
└- 29	Forced PV (instantaneous flow rate) zero function	0: Function disabled 1: Function enabled	0	Instantaneous flow rate is made zero forcibly after the flow rate is set to zero or the mode is changed to valve forced fully closed mode and delay time has elapsed. Instantaneous flow rate variation in zero position caused by the inclination of pipe is neglected. Delay time is set in parameter setup mode. ☞ 5-2 Parameters (page 5-11).
└- 30 *4	Communications address setting	0: Communications function disabled 1 to 127: Communications address	0	
└- 31 *4	Transfer speed selection	0: 38400bps 1: 19200bps 2: 9600bps 3: 4800bps 4: 2400bps	1	
└- 32 *4	Data format selection	0: 8 data bits, even parity, 1 stop bit 1: 8 data bits, no parity, 2 stop bits	0	
└- 35	SP limit function	0: SP limit function disabled 1: Only upper limit enabled 2: Only lower limit enabled 3: Upper and lower limits enabled	0	The upper and lower limit values of the flow rate setup range can be set to desired levels. Upper and lower limits are set in parameter setup mode. ☞ 5-2 Parameters (page 5-11).

Display Item	Item Description	Setup Item and Description	Factory Setting	Remarks
└- 36 *5	Operational differential pressure setting (control optimization)	0: Low differential pressure (50 ± 50kPa) 1: Standard differential pressure (200 ± 100kPa) 2: High differential pressure (300+0, -100kPa)	1	When the setting corresponds to the actual operating differential pressure, control can be optimized. (When "0" is set, the control response speed becomes fast. When "2" is set, the control response speed becomes slow.)
└- 37 *6	Flow rate display unit change function	0: Flow rate is displayed in the standard flow rate unit. 1: Flow rate is displayed in [L/min] at all times. -1: Flow rate is displayed in [mL/min] at all times.	0	0: When the flow rate range or gas type is changed, the unit is automatically changed to the display unit so that the range after change becomes the maximum resolution. 1: A value less than 0.001[L/min] is not displayed
└- 38	PV (instantaneous flow rate) display decimal point position change function	0: Decimal point position is not changed 1: Decimal point position is shifted one digit left -1: Decimal point position is shifted one digit right	0	The decimal point position of the SP display is not changed. 1: When the standard decimal point position is the 4th digit (0.xxx), the function is invalid even though this setting is selected. If the flow rate exceeds the display range, a dash is displayed for all digits (----). -1: When the standard flow rate display does not have a decimal point, it is invalid even though this function is selected.

- *1. When "4: flow rate setting method switching" is selected in the external contact inputs └- 10 to └- 12 in the function setup, switching according to external input takes precedence.
- *2. According to the settings in └- 05 and └- 06, the analog input and output ranges are changed as shown in the table below.

Settings in └- 06	Settings in function setup └- 05		
	0	1	2
0	0 to 5V internal reference input/ 0 to 5V instantaneous flow rate output	0 to 5V external reference input/ 0 to 5V instantaneous flow rate output	1 to 5V external reference input/ 0 to 5V instantaneous flow rate output
1	0 to 5V internal reference input/ 1 to 5V instantaneous flow rate output	0 to 5V external reference input/ 1 to 5V instantaneous flow rate output	1 to 5V external reference input/ 1 to 5V instantaneous flow rate output
2	0 to 20mA external reference input/ 0 to 20mA instantaneous flow rate output	0 to 20mA external reference input/ 0 to 20mA instantaneous flow rate output	4 to 20mA external reference input/ 0 to 20mA instantaneous flow rate output
3	0 to 20mA external reference input/ 4 to 20mA instantaneous flow rate output	0 to 20mA external reference input/ 4 to 20mA instantaneous flow rate output	4 to 20mA external reference input/ 4 to 20mA instantaneous flow rate output
4	0 to 5V internal reference input/ 0 to 5V setting flow rate output	0 to 5V external reference input/ 0 to 5V setting flow rate output	1 to 5V external reference input/ 0 to 5V setting flow rate output
5	0 to 5V internal reference input/ 1 to 5V setting flow rate output	0 to 5V external reference input/ 1 to 5V setting flow rate output	1 to 5V external reference input/ 1 to 5V setting flow rate output
6	0 to 20mA external reference input/ 0 to 20mA setting flow rate output	0 to 20mA external reference input/ 0 to 20mA setting flow rate output	4 to 20mA external reference input/ 0 to 20mA setting flow rate output
7	0 to 20mA external reference input/ 4 to 20mA setting flow rate output	0 to 20mA external reference input/ 4 to 20mA setting flow rate output	4 to 20mA external reference input/ 4 to 20mA setting flow rate output

- *3. When "4: Switching of analog I/O voltage range" is selected for external 3-way switching function assignment $\zeta-09$ in the function setup, external 3-way switching input takes precedence over others. Additionally, the analog input and output ranges change as shown in the table below according to the input status and the setting status of $\zeta-05$.

Settings in $\zeta-05$	External 3-way switching input state		
	OPEN	0V	5V
0	0 to 5V internal reference input/	0 to 5V external reference input/	1 to 5V external reference input/
1	0 to 5V instantaneous flow rate output	0 to 5V instantaneous flow rate output	1 to 5V instantaneous flow rate output
2	0 to 20mA external reference input/	0 to 20mA external reference input/	4 to 20 mA external reference input/
3	0 to 20mA instantaneous flow rate output	0 to 20mA instantaneous flow rate output	4 to 20mA instantaneous flow rate output
4	0 to 5V internal reference input/	0 to 5V external reference input/	1 to 5V external reference input/
5	0 to 5V setting flow rate output	0 to 5V setting flow rate output	1 to 5V setting flow rate output
6	0 to 20mA external reference input/	0 to 20mA external reference input/	4 to 20 mA external reference input/
7	0 to 20mA setting flow rate output	0 to 20mA setting flow rate output	4 to 20 mA setting flow rate output

- *4. This setting can be made only for models with RS-485 communications.
 *5. This setting cannot be made for the MQV0050 (J, K).
 *6. This setting can be made only for the MQV9200/9500/0002/0005.

Handling Precautions

- When the operational differential pressure setting ($\zeta-35$) is changed to "0: Low differential pressure ($50 \pm 50\text{kPa}$)," always use the device with an operational differential pressure less than 100kPa. Failure to do so may cause overshoot or hunting of the flow rate.

5 - 2 Parameters

This section describes parameter setup.

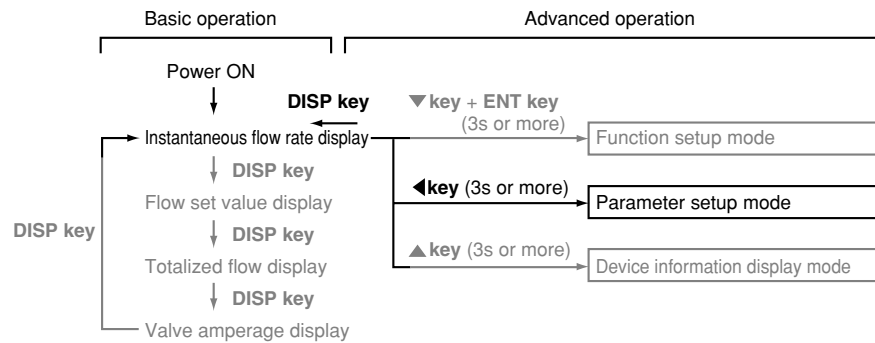

■ Setup method

Follow the procedure below to set constants such as flow rate deviation alarm upper and lower limit setting values and event output delay times :

(1) Press the **DISP key** several times to display the instantaneous flow rate.

>>The PV and L/min lamps light (mL/min in MQV9200).

(2) Hold down the **◀ key** for three seconds or more.

>> Item No. **0.000** is displayed on the 7-segment display and the mode changes to the parameter setup mode.

(3) Press the **▲** or **▼ key** to select the desired setup item numbers, and press the **ENT key**.

>>The current setting blinks on the 7-segment display.

(4) Press the **▲** or **▼ key** to change the setting to the desired setting. You can move to the digit to be changed by pressing the **◀ key**.

(5) When you have finished changing the setting, press the **ENT key** to enter the setting.

>>At this point, the setting is updated.

(6) If you want to set up other items, return to step (3) and repeat the procedure. Otherwise, proceed to step (7).

(7) Press the **DISP key**.

>>The mode return to the instantaneous flow rate mode from the parameter setup mode.

! Handling Precautions

- If you do not press any keys for one minute after entering the parameter setup mode, the display automatically returns to the regular (instantaneous flow rate) display.
- If you press the **DISP key** without pressing the **ENT key** after carrying out step (4), the setting remains at the previous value without being updated.

■ Parameter setup item list

No.	Display	Description	Factory Setting	Setting Range	Related Function Setup	Remarks
1	<i>O.rng</i> *1	Flow rate OK judgment range	(2% FS) *14	(0.5 to 100% FS) *14	<i>C-07</i> <i>C-08</i> <i>C-22</i>	Unit: L/min (standard) (mL/min (standard) for the MQV9005/9020/9200.)
2	<i>O.HYS</i> *1	Flow rate OK judgment hysteresis	(1% FS) *14	(0.5 to 100% FS) *14		
3	<i>R.HI</i> *2, *3	Instantaneous flow rate deviation upper limit alarm	(10% FS) *14	(0.5 to 100% FS) *14	<i>C-15</i> <i>C-16</i>	
4	<i>R.HHY</i> *2, *3	Instantaneous flow rate deviation upper limit alarm hysteresis	(2% FS) *14	(0.5 to 100% FS) *14		
5	<i>R.Lo</i> *2, *3	Instantaneous flow rate deviation lower limit alarm	(10% FS) *14	(0.5 to 100% FS) *14		
6	<i>R.LHY</i> *2, *3	Instantaneous flow rate deviation lower limit alarm hysteresis	(2% FS) *14	(0.5 to 100% FS) *14		
7	<i>R.dLY</i> *4	Flow rate deviation alarm/valve amperage alarm judgment delay time	10.0s	0.5 to 999.9s	<i>C-15</i> <i>C-16</i> <i>C-20</i>	
8	<i>E.1.dL</i> *5	Event 1 output delay	0.0s	0.0 to 999.9s	<i>C-07</i> <i>C-08</i>	Delay does not apply to totalizer pulse output.
9	<i>E.2.dL</i> *5	Event 2 output delay	0.0s	0.0 to 999.9s		
10	<i>C.F.</i> *6	User setup conversion factor	1.000	0.100 to 9.999	<i>C-18</i> <i>C-26</i>	
11	<i>R.I.HI</i> *7	Valve amperage upper limit alarm	100.0%	0.1 to 100.0%	<i>C-16</i> <i>C-20</i>	At the factory setting, alarms are not detected. ☞ Handling Precautions, page 5-14.
12	<i>R.I.Lo</i> *7	Valve amperage lower limit alarm	0.0%	0.0 to 99.9%		
13	<i>E.1.SP</i> *8	Event 1 output upper/lower limit flow rate setup	(0% FS) *14	(0 to 100% FS) *14	<i>C-07</i> <i>C-08</i>	Unit: L/min (standard) (mL/min (standard) for the MQV9200)
14	<i>E.2.SP</i> *8	Event 2 output upper/lower limit flow rate setup	(0% FS) *14	(0 to 100% FS) *14		
15	<i>r.RP.1</i> *9	SP ramp control ramp 1	0	MQV9200/9500 : 0.0 to 999.9 MQV9005/0002/ 0005: 0.000 to 9.999	<i>C-27</i>	Sets the flow rate change per second. Flow rate unit:L/min (standard) (mL/min (standard) for the MQV9200 / 9500) Ramp control does not function if the value stays at the factory setting (ramp zero). (The SP takes effect immediately after a change. The update cycle for the SP is 5 ms.)
16	<i>r.RP.2</i> *9	SP ramp control ramp 2		MQV9005/0002/ 0.00 to 99.99 MQV0200/0500 : 0005: 0.0 to 999.9		

No.	Display	Description	Factory Setting	Setting Range	Related Function setup	Remarks
17	<i>R.SCL</i> *10	Optional analog scaling	(100% FS) *14	(10 to 100% FS) *14	<i>└-28</i>	Sets the flow rate corresponding to 100% of analog input / output (5V). Unit: L/min(standard) (mL/min (standard) for the MQV9005/9020/9200.)
18	<i>E.R.Lo</i> *11	Cumulative flow event setting (last 4 digits)	0	0 to 9999	<i>└-07</i> <i>└-08</i> <i>└-13</i>	The unit (decimal point position) may vary depending on the model. ☞ Flow rate totalization (page 1-3).
19	<i>E.R.Hi</i> *11	Cumulative flow event setting (first 4 digits)	0	0 to 9999		
20	<i>P.O.dL</i> *12	PV forced zero function delay	3.0s	0.0 to 999.9s	<i>└-29</i>	
21	<i>SP.L.H</i> *13	SP upper limit flow rate	(100% FS) *14	(0 to 100% FS) *14	<i>└-35</i>	Unit: L/min (standard) (mL/min [standard] for the MQV9005/9020/9200)
22	<i>SP.L.L</i> *13	SP lower limit flow rate	(0% FS) *14	(0 to 100% FS) *14		

*1. Operation during judgment of flow rate OK.

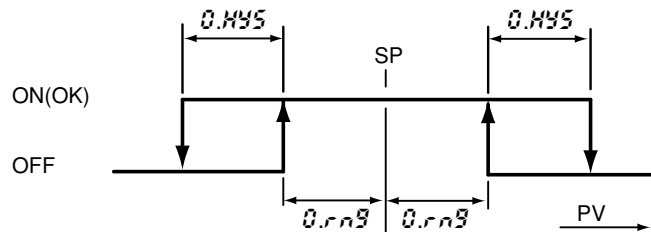

*2. Operation during judgment of flow rate deviation upper and lower limit alarms

Be sure to set so that $R.Lo \geq R.L.HY$ or $R.Hi \geq R.H.HY$.

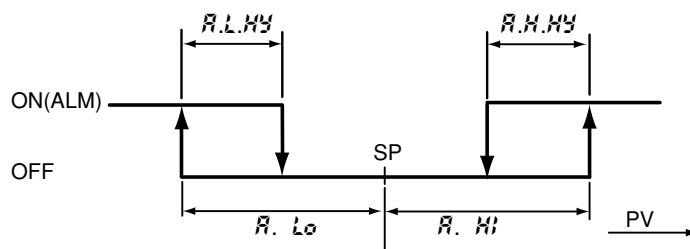

3. Only items corresponding to the alarm type selected in flow rate alarm setup (└-15* in the function setup) can be set.

4. These alarms can be set when (1 to 3) is set for flow rate alarm setup type (└-15*) and valve amperage alarm setup type (*└-20*) in the function setup.

*5. This cannot be set when "0: Not used (OFF all times)" has been selected for *└-07* and *└-08* event output type assignment in the function setup.

*6. This can be set only when "0: Conversion factor for each gas type set by the user" has been selected for the *└-18* or *└-26* gas type selection 1 or 2 in the function setup.

*7. This can be set only if a suitable alarm type is selected in the *└-20* valve amperage alarm setup (in the function setup).

- *8. This can be set only when "8 to 10: PV upper / lower limit event 1, 2" has been selected for the $\zeta-07$ and $\zeta-08$ event output type assignment in the function setup.
- *9. This can be set only when "1 and 2: SP ramp control" has been selected for the $\zeta-27$ SP ramp control function in the function setup.
- *10. This can be set only when "1: Function enabled" has been selected for the $\zeta-28$ analog optional scaling function in the function setup.
- *11. This can be set only when "1: Cumulative flow event" has been selected as event output type in $\zeta-07$ or $\zeta-08$ in the function setup or when "1: Function enabled" has been selected for the automatic valve shut-off function upon occurrence of the cumulative flow event ($\zeta-13$).
- *12. This can be set only when "1: Function enabled" has been selected for the $\zeta-29$ forced PV zero function in the function setup.
- *13. This can be set only if suitable limit type is selected for the $\zeta-35$ SP limit function in the function setup.
- *14. When the full scale flow rate is changed by changing function setup $\zeta-18$ or $\zeta-26$ (gas type setup) or $\zeta-24$ or $\zeta-25$ (control flow rate range setting), the parameter setup must also be changed. In this case, the setting range can be obtained by multiplying the modified full scale flow rate by the ratio enclosed in brackets.

Handling Precautions

- The valve amperage changes greatly according to the differential pressure even if the flow rate is the same. For this reason, the valve amperage alarm function cannot be used under unstable differential pressure conditions.
- Even under stable differential pressure conditions, hysteresis characteristics (electric current to the valve differs even if the flow rate is the same) are applied to the relationship between the valve amperage and the flow rate. So, to use the valve amperage alarm function, first sufficiently test under operating conditions to check the valve amperage range, and then determine the alarm amperage setting.

5 - 3 Device Information Display

This section describes device information display.

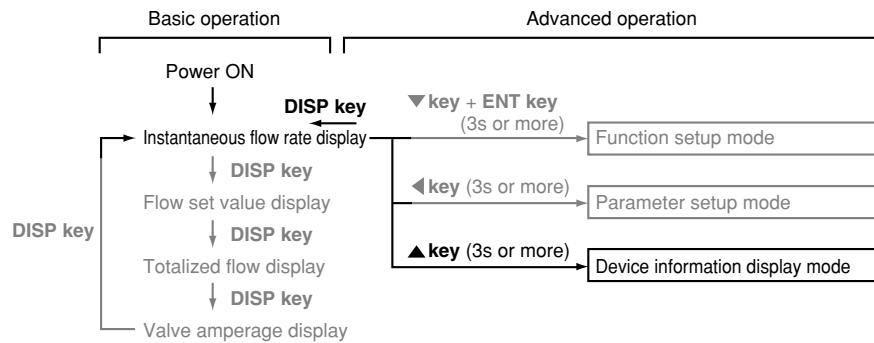

■ Setup method

Four items of those set on the device, that is, gas type, full-scale flow rate, reference temperature, and communications address* are displayed sequentially.

(1) Press the **DISP key** several times to display the instantaneous flow rate.

>>The instantaneous flow rate is displayed and the PV and L/min lamps light (the mL/min lamp lights on the MQV9005/9020/9200)

(2) Hold down the **▲ key** for three seconds or more.

>>The **RS5** is displayed on the 7-segment display and the mode changes to the device information display mode.

(3) Release the **▲ key** once.

(4) Press the **▲** or **▼ key** to select the desired setting.

>> When releasing the key, the display item and currently set value are alternately displayed automatically.

(5) If you want to set up other items, return to step (3) and repeat the procedure. Otherwise, proceed to step (6).

(6) Press the **DISP key**.

>>The mode returns to the instantaneous flow rate display mode.

*The communications address is displayed only on models with the RS-485 communications option.

! Handling Precautions

- If you do not press any keys for one minute after entering the device information display mode, the display automatically returns to the instantaneous flow rate display.

■ Device information display item

No.	Display Item	Description	Setting Range and Description	Related Function Setup	Remarks
1	GR5	Gas type	0: Conversion factor for each gas type set by the user 1: Air/nitrogen 2: Oxygen 3: Argon 4: Carbon dioxide (CO ₂) 5: Natural gas 13A(LNG) (Heating value: 46MJ/m ³) 6: 100% propane 7: 100% methane 8: 100% butane 11: Natural gas 13A(LNG) (Heating value: 45MJ/m ³)	℄-18, ℄-26	
2	F.SCL	Full-scale flow rate	(10 to 100% of standard range)	℄-18, ℄-24, ℄-25, ℄-26	Unit: L/min(standard) (mL/min [standard] for the MQV9005/9020/9200)
3	S.dEG	Reference temperature	0 to 35	℄-19	Unit: °C
4	℄.RdS*	Communications address	0 to 127	℄-30	"0" means communications function disabled.

*Only for models with RS-485 communications.

5 - 4 Flow Rate Range Change Function and Settings and Display Resolutions After Change of Range

The flow rate range can be reduced to a level of 99% down to 10% of the standard range using the flow rate range setup (ξ-24 or ξ-25). However, the minimum control flow rate is the same as for the standard range. As the range is reduced, the setup and display resolution levels are improved as described in the table below.

Settings and display resolutions after change of range

MQV9005		MQV9020		MQV9200		MQV9500 (Note)	
Full scale flow rate [mL/min]	Resolution [mL/min]	Full scale flow rate [L/min]	Resolution [L/min]	Full scale flow rate [L/min]	Resolution [L/min]	Full scale flow rate [L/min]	Resolution [L/min]
5.00 to 3.02	0.02	—	—	—	—	0.500 to 0.302	0.002
3.00 to 1.21	0.01	20.0 to 12.1	0.1	200 to 121	1	0.300 to 0.121	0.001
1.200 to 0.302	0.005	12.00 to 6.05	0.05	120.0 to 60.5	0.5	(120.0 to 60.5)	(0.5)
0.600 to 0.302	0.002	6.00 to 3.02	0.02	60.0 to 30.2	0.2	(60.0 to 30.2)	(0.2)
0.300 to 0.100	0.001	3.00 to 1.00	0.01	30.0 to 10.0	0.1	(30.0 to 10.0)	(0.1)

Note: The display unit of the flow rate shown in () for the MQV9500 is mL/min.

MQV0002		MQV0005		MQV0020		MQV0050	
Full scale flow rate [mL/min]	Resolution [mL/min]	Full scale flow rate [L/min]	Resolution [L/min]	Full scale flow rate [L/min]	Resolution [L/min]	Full scale flow rate [L/min]	Resolution [L/min]
—	—	5.00 to 3.02	0.02	—	—	50.0 to 30.2	0.2
2.00 to 1.21	0.01	3.00 to 1.21	0.01	20.0 to 12.1	0.1	30.0 to 12.1	0.1
1.200 to 0.605	0.005	1.200 to 0.605	0.005	12.00 to 6.05	0.05	12.0 to 6.05	0.05
0.600 to 0.302	0.002	0.600 to 0.302	0.002	6.00 to 3.02	0.02	6.00 to 3.02	0.02
0.300 to 0.100	0.001	0.300 to 0.100	0.001	3.00 to 1.00	0.01	3.00 to 1.00	0.01

MQV0200		MQV0500	
Full scale flow rate [L/min]	Resolution [L/min]	Full scale flow rate [L/min]	Resolution [L/min]
—	—	500 to 302	2
200 to 121	1	300 to 121	1
120.0 to 60.5	0.5	120.0 to 60.5	0.5
60.0 to 30.2	0.2	60.0 to 30.2	0.2
30.0 to 10.0	0.1	30.0 to 10.0	0.1

! Handling Precautions

- Even after flow rate range is changed, the accuracy specifications are the same as for the standard range. (The full scale designated by % FS shows the numeric value of the standard range.)
- Even though the flow rate range is changed, the minimum control flow rate is the same as for the standard range.
- The scaling of the analog input/output is automatically changed to ensure that the modified flow rate range is FS.

■ Setup resolution in the analog setup

When "1: Analog setup" is selected in $\zeta-03$ (flow rate setup) and setup is done using an external analog voltage or analog current, a higher resolution can be set than in the digital setup.

Analog setup signal	Flow rate setup resolution
0 to 5V or 0 to 20mA	About 1/3700 of the full scale flow rate
1 to 5V or 4 to 20mA	About 1/3000 of the full scale flow rate

Example: Setting MQV0050 (50L/min range) with an analog current of 4 to 20mA

Setup resolution $\approx 50\text{L/min} \div 3000 \approx 0.017\text{L/min}$ (standard)

Chapter 6. MAINTENANCE AND TROUBLESHOOTING

■ Alarm code display

When a flow rate deviation alarm occurs or when an alarm occurs during self-diagnostics, the device forcibly switches to the operating mode currently selected for “Operation selection at alarm occurrence” (C-15 in the function setup). Additionally, the alarm code and normal display are alternately shown at the upper 4-digit portion of the 7-segment display.

Alarm Code	Problem	Causes	Remedy
<i>RL01</i>	Flow rate deviation lower limit alarm	Insufficient alarm judgment delay/power voltage/inlet pressure, excessive inlet pressure/operating temperature, etc.	If items under causes do not help, ask for repair.
<i>RL02</i>	Flow rate deviation upper limit alarm	Insufficient alarm judgment delay, valve trouble, sensor trouble, etc.	Ask for repair if the delay is not a problem.
<i>RL11</i>	Valve amperage lower limit alarm	Insufficient alarm judgment delay, alarm setting current value too high, excessive inlet pressure, etc.	Set parameter setup again.
<i>RL12</i>	Valve amperage upper limit alarm	Insufficient alarm judgment delay, alarm setting current value too low, insufficient power voltage, insufficient inlet pressure, etc.	Set parameter setup again.
<i>RL71</i>	Valve overheat prevention limit operation	The gas is forcibly closed outside for 5 minutes or longer in the control or fully open mode.	If you close the gas continuously from the outside, set the setting flow rate to zero (0) or put the valve in the fully closed mode.
<i>RLB1</i>	Sensor error 1 (Heater voltage error)	Sensor trouble, foreign object on sensor, condensation on sensor, influx of hydrogen or helium gas, etc.	Remove the probable causes. If the device does not return to normal operation even after the power has been shutdown for a while, ask for repair.
<i>RLB2</i>	Sensor error 2 (Measured flow rate signal error)	Sensor trouble, foreign object on sensor, back current, etc.	
<i>RL91</i>	Adjustment data error	Data corrupted due to electrical noise.	Ask for repair
<i>RL92</i>	Sensor calibration data error	Data corrupted due to electrical noise.	Ask for repair
<i>RL93</i>	User setup data error	Power shut-off during user setup data writing.	Set data again.

! Handling Precautions

- The alarm code is displayed only when the instantaneous flow rate or totalized flow is displayed.
- *RL71* (valve overheat prevention limit operation) is activated only in the MQV0050(J, K)/0200(J, K)/0500(J, K). At this time, the current to the valve is forcibly limited regardless of the selection of C-15 in the function setup.
- If a sensor error (*RLB1* or *RLB2*) occurs, the flow rate measurement value will become indefinite. Therefore, the control flow rate becomes indefinite even if "0, 1, -1: Control continued" was selected for C-15 in the function setup.

- If the causes of the alarm are removed, the alarm display turns off automatically. However, when "2, -2: Forced fully closed" or "3, -3: Forced fully open" is selected for ζ -15 in the function setup, the alarm display and operating mode at alarm occurrence are retained even if the causes of the alarm are removed.

● **Alarm reset operation**

When the ENT key is kept pressed continuously while the instantaneous flow rate is being displayed, the alarm is reset after 3 seconds have elapsed.

■ **Troubleshooting guide**

Observation	Causes	Remedy
Flow rate display does not become zero even with an actual zero flow rate. (Display is not 0.00 even if the valve is fully closed.)	<ul style="list-style-type: none"> • The device is installed on the vertical (or inclined) piping. • Condensation on sensor • Zero point of sensor has deviated • Foreign object on sensor 	<ul style="list-style-type: none"> • Install in horizontal piping or use the forced PV zero function (function setup ζ-29). • Insert a mist trap upstream. • Adjust the flow rate zero • Ask for repair.
Flow rate does not stabilize.	<ul style="list-style-type: none"> • Operating differential pressure range is exceeded. • Inlet pressure fluctuates greatly. • Regulator interference • Large pressure loss in piping (inlet pressure fluctuates greatly according to flow rate.) • Check valve vibration. • Operating differential pressure setting (function setup ζ-35) does not match the actual operating differential pressure. 	<ul style="list-style-type: none"> • Lower the primary pressure. • Insert a regulator upstream. • Change the pressure setting on the pressure regulator or increase the capacity of the pipe between the MQV and the regulator. • Apply the instantaneous PV filter (function setup ζ-23). • Use larger diameter pipe. • In the case of a device causing a large pressure loss, either remove the device or install larger capacity piping between the MQV and the device. • Change the check valve to one having a low cracking pressure. • Adjust the operating differential pressure setting to the actual operating differential pressure or set "2" for the operating differential pressure setup.
Poor accuracy	<ul style="list-style-type: none"> • Temperature reference does not match the reference flow meter. • Regulator is vibrating slightly. • Foreign object stuck on sensor 	<ul style="list-style-type: none"> • Match the temperature reference. (Change in ζ-19 in the function setup.) • Change the regulator pressure setting. • Ask for repair.

● Flow rate zero adjustment

If a cause of the flow rate does not becoming zero in spite of an actual zero flow rate is that the sensor's zero point has deviated, adjust the flow rate zero point as follows:

- (1) Press the DISP key to display the instantaneous PV display.
(The PV and L/min lamps light (mL/min in MQV9005/9020/9200).)
- (2) Set the operating mode to the fully closed mode, or set the setting flow rate to zero, and fully close the valve.
- (3) Continue pressing the ENT key in this state.
- (4) After about 10 seconds, $0. \text{LRL}$ is indicated on the display. After about one second, release the ENT key.
- (5) The display changes to $0FF$. (Flow rate zero adjustment is completed.)

Handling Precautions

Perform flow rate zero adjustment with the actual flow rate stabilized to zero after completely replacing the inside of the flow path with the gas to be controlled.

Note

- Flow rate zero adjustment can be performed by external contact input by selecting “flow rate zero adjustment” for $\zeta - 10$ to $\zeta - 12$ in the function setup. For details on how to set up functions, See Chapter 5, ADVANCED OPERATION.

Chapter 7. SPECIFICATIONS

■ **Specifications** (shown on next page)

● MQV9005/9020

Item		Model No.	MQV9005	MQV9020
Valve type			Proportional solenoid valve	
Valve operation			Normally closed when de-energized (N.C.)	
Standard full-scale flow rate		*1	5 mL/min(standard)	20 mL/min(standard)
Gas types			Air/nitrogen (N ₂), oxygen (O ₂), argon (Ar) Gas must be dry and not contain corrosive components (chlorine, sulfur, acid). The gas must also be clean, not containing dust or oil mist.	
Control	Range		2 to 100% FS (see “Gas type and control range” table (page 7-11))	1 to 100% FS (see “Gas type and control range” table (page 7-11))
	Valve output update cycle		5ms	
	Response (at standard differential pressure)		Within 0.3s at setting ±2% FS (typ.) (Control starts from the fully closed status or the setting is changed during control.)	
	Accuracy (at standard temperature and differential pressure, Q: flow rate)	*2	±1%FS	
	Repeatability (Q: flow rate)		±0.5%	
	Temperature characteristics (with air)		0.06% FS max. per 1°C	
	Pressure characteristics (with air)		0.2% FS max. per 100kPa	
Pressure	Standard differential pressure	*3	100kPa (inlet pressure: 100kPa (gauge), outlet pressure: 0kPa (gauge))	
	Required differential pressure	*4	5kPa	30kPa
	Operating differential pressure range	*5	300kPa max.	
	Allowable inlet pressure	*6	0.5MPa (gauge)	
	Pressure resistance		1MPa (gauge)	
Temperature	Standard operating temperature	*3	+23°C	
	Allowable operating temperature range		-10 to +60°C	
	Allowable storage temperature range		-20 to +70°C	
Humidity	Allowable operating humidity range		10 to 90% RH (condensation not allowed)	
External leaks	Helium leak rate		Within 1 x 10 ⁻⁶ Pa·m ³ /s	
Flow rate setup	Setup method		(1) Key operation (2) External analog input (3) Dedicated loader communications (4) RS-485 communications (3 wire-system)	*7 *8
	Setup resolution		See “Gas type and control range” table (page 7-11).	
	External analog input		Input range: 0 to 5Vdc/1 to 5Vdc/0 to 20mA/4 to 20mA (switchable) Input impedance: 1MΩ±10% (voltage input), 250Ω±10% (current input)	

Item		Model No.	MQV9005	MQV9020
Flow rate display	Display method	7-segment LED, 4 digits		
	Setup resolution	See "Gas type and control range" table (page 7-11).		
	Indication accuracy (at standard temperature and differential pressure)	$\pm 1\%FS \pm 1$ digit		
Totalizing function	Display range	0.0 to 9,999,999.9mL	0.00 to 99,999,999mL	
	Display resolution	0.1mL	1mL	
	Totalized count backup timing	(1) Every 50mL (2) Every hour from the previous backup (3) At the time the RUN key is pressed.	(1) Every 200mL	
Analog output	Output type	Instantaneous flow rate (PV) output or setting flow rate (SP) output (switchable)		
	Output scale	0 to full-scale flow rate (scale can be changed)		
	Output range	0 to 5Vdc/1 to 5Vdc/0 to 20mA/4 to 20mA (switchable)		
	Max. output	7Vdc or 28 mA (max. output when flow rate exceeds the range).		
	Accuracy	$\pm 0.3\%FS$ (Total output accuracy: Indication accuracy $\pm 0.3\%FS$)		
	External resistance	Voltage output type: 250k Ω min. Current output type: 300 Ω max.		
Alarm/event output	Number of outputs	Alarm output: 1, Event output: 2		
	Output rating	30Vdc, 30mA max. (open collector non-insulated output)		
	Totalized pulse output width	100ms $\pm 10\%$ (when pulse output is selected in the function setup)		
	Totalized pulse output rate	0.1mL/1 pulse	1mL/1 pulse	
External switching input	Input type, number of inputs	External 3-way switching input (OPEN/GND/5V): 1 External contact input (2-way switching): 3		
	Required circuit type	Non-voltage contact, or open collector		
	Contact OFF terminal voltage	External 3-way switching input: 2.5 $\pm 0.5V$ External contact input: 2.8 $\pm 0.5V$		
	Contact ON terminal current	Approx. 0.5mA (current flowing to contact)		
	Allowable ON contact resistance	250 Ω max.		
	Allowable OFF contact resistance	100k Ω min.		
	Allowable ON residual voltage	1.0V max. (open collector type)		
	Allowable OFF leakage current	50 μA max. (open collector type)		
Reference voltage output	Output rating	5.0Vdc $\pm 5\%$, 5mA max.		
	Application	Reference voltage of flow rate setting voltage and 5V input of external 3-way switching input		
Communications	Mode	Dedicated loader communications RS-485 communications (3-wire system)		*7 *8
	Transmission speed	2400, 4800, 9600, 19200, 38400 bps (loader communications: 19200bps only)		
Power	Rating	24Vdc, current consumption: 300mA max.		
	Allowable power voltage range	21.6 to 26.4Vdc (ripple 5% max.)		
	Isolation	The power circuit is isolated from the input/output circuit.		
Material of gas-contacting parts	SUS316, Teflon, Fluororubber, borosilicate glass, silicone			
Connection method	1/4" Swagelok, 1/4" VCR			
Mounting orientation	Horizontal. Be sure that display surface does not face down.			
Mass	Approx. 1.1 kg			
Applicable standards	EN61326-2-3: 2013, EN61326-1: 2013 (To be used in an industrial electromagnetic environment) During EMC testing, the reading or output may fluctuate by the equivalent of $\pm 10\%FS$.			

● MQV9200/9500/0002

Item		Model No.	MQV9200	MQV9500	MQV0002
Valve type		Proportional solenoid valve			
Valve operation		Normally closed when de-energized (N.C.)			
Standard full-scale flow rate		*1	200 mL/min(standard)	0.500 L/min(standard)	2.00 L/min(standard)
Gas types		Air/nitrogen (N ₂), oxygen (O ₂), argon (Ar), carbon dioxide (CO ₂), natural gas 13A (LNG), 100% methane (CH ₄), 100% propane (C ₃ H ₈), 100% butane (C ₄ H ₁₀) Gas must be dry and not contain corrosive components (chlorine, sulfur, acid). The gas must also be clean, not containing dust or oil mist.			
Control	Range	1 to 100% FS (see "Gas type and control range" table (page 7-11))			
	Valve output update cycle	5ms			
	Response (at standard differential pressure)	Within 0.3s at setting ±2% FS (typ.) (Control starts from the fully closed status or the setting is changed during control.)			
	Accuracy (at standard temperature and differential pressure, Q: flow rate)	*2 (1) ±1%FS (50%FS < Q ≤ 100% FS) (2) ±0.5% FS (0% FS ≤ Q ≤ 50% FS)			
	Repeatability (Q: flow rate)	(1) ±0.5% FS (50% FS < Q ≤ 100% FS) (2) ±0.25% FS (0% FS ≤ Q ≤ 50% FS)			
	Temperature characteristics (with air)	0.06% FS max. per 1°C			
	Pressure characteristics (with air)	0.2% FS max. per 100kPa			
Pressure	Standard differential pressure	*3	200kPa (inlet pressure: 200kPa (gauge), outlet pressure: 0kPa (gauge))		
	Required differential pressure	*4	50kPa	5kPa	50kPa
	Operating differential pressure range	*5	300kPa max.		
	Allowable inlet pressure	*6	0.5MPa (gauge)		
	Pressure resistance		1MPa (gauge)		
Temperature	Standard operating temperature	*3	+23°C		
	Allowable operating temperature range		-10 to +60°C		
	Allowable storage temperature range		-20 to +70°C		
Humidity	Allowable operating humidity range		10 to 90% RH (condensation not allowed)		
External leaks	Helium leak rate (1/4" VCR connection type)		Within 1 x 10 ⁻⁶ Pa·m ³ /s		
Flow rate setup	Setup method		(1) Key operation (2) External analog input (3) Dedicated loader communications (4) RS-485 communications (3 wire-system)		*7 *8
	Setup resolution		See "Gas type and control range" table (page 7-11).		
	External analog input		Input range: 0 to 5Vdc/1 to 5Vdc/0 to 20mA/4 to 20mA (switchable) Input impedance: 1MΩ±10% (voltage input), 250Ω±10% (current input)		

Item		Model No.	MQV9200	MQV9500	MQV0002
Flow rate display	Display method	7-segment LED, 4 digits			
	Setup resolution	See "Gas type and control range" table (page 7-11).			
	Indication accuracy (at standard temperature and differential pressure; Q: flow rate)	(1) $\pm 1\%FS \pm 1$ digit ($50\%FS < Q \leq 100\%FS$) (2) $\pm 0.5\%FS \pm 1$ digit ($0\%FS \leq Q \leq 50\%FS$)			
Totalizing function	Display range	0.00 to 999,999.99L	0.00 to 999,999.99L	0.0 to 9,999,999.9L	
	Display resolution	0.01L	0.01L	0.1L	
	Totalized count backup timing	(1) Every 2L (2) Every hour from the previous backup (3) At the time the RUN key is pressed.	(1) Every 5L	(1) Every 20L	
Analog output	Output type	Instantaneous flow rate (PV) output or setting flow rate (SP) output (switchable)			
	Output scale	0 to full-scale flow rate (scale can be changed)			
	Output range	0 to 5Vdc/1 to 5Vdc/0 to 20mA/4 to 20mA (switchable)			
	Max. output	7Vdc or 28 mA (max. output when flow rate exceeds the range).			
	Accuracy	$\pm 0.3\%FS$ (Total output accuracy: Indication accuracy $\pm 0.3\%FS$)			
	External resistance	Voltage output type: 250k Ω min. Current output type: 300 Ω max.			
Alarm/event output	Number of outputs	Alarm output: 1, Event output: 2			
	Output rating	30Vdc, 30mA max. (open collector non-insulated output)			
	Totalized pulse output width	100ms $\pm 10\%$ (when pulse output is selected in the function setup)			
	Totalized pulse output rate	0.01L/1 pulse	0.01L/1 pulse	0.1L/1 pulse	
External switching input	Input type, number of inputs	External 3-way switching input (OPEN/GND/5V): 1 External contact input (2-way switching): 3			
	Required circuit type	Non-voltage contact, or open collector			
	Contact OFF terminal voltage	External 3-way switching input: 2.5 $\pm 0.5V$ External contact input: 2.8 $\pm 0.5V$			
	Contact ON terminal current	Approx. 0.5mA (current flowing to contact)			
	Allowable ON contact resistance	250 Ω max.			
	Allowable OFF contact resistance	100k Ω min.			
	Allowable ON residual voltage	1.0V max. (open collector type)			
	Allowable OFF leakage current	50 μA max. (open collector type)			
Reference voltage output	Output rating	5.0Vdc $\pm 5\%$, 5mA max.			
	Application	Reference voltage of flow rate setting voltage and 5V input of external 3-way switching input			
Communications	Mode	Dedicated loader communications RS-485 communications (3-wire system)			*7 *8
	Transmission speed	2400, 4800, 9600, 19200, 38400 bps (loader communications: 19200bps only)			
Power	Rating	24Vdc, current consumption: 300mA max.			
	Allowable power voltage range	21.6 to 26.4Vdc (ripple 5% max.)			
	Isolation	The power circuit is isolated from the input/output circuit.			
Material of gas-contacting parts		SUS316, Teflon, Fluororubber			
Connection method		9/16-18UNF, Rc 1/4", 1/4" Swagelok, 1/4" VCR			
Mounting orientation		Horizontal. Be sure that display surface does not face down.			
Mass		Approx. 1.2kg			
Applicable standards		EN61326-2-3: 2013, EN61326-1: 2013 (To be used in an industrial electromagnetic environment) During EMC testing, the reading or output may fluctuate by the equivalent of $\pm 10\%FS$.			

● MQV0005/0020/0050(B, C)

Item		Model No.	MQV0005	MQV0020	MQV0050 (B, C)
Valve type		Proportional solenoid valve			
Valve operation		Normally closed when de-energized (N.C.)			
Standard full-scale flow rate		*1	5.00L/min(standard)	20.0L/min(standard)	50.0 L/min(standard)
Gas types		Air/nitrogen (N ₂), oxygen (O ₂), argon (Ar), carbon dioxide (CO ₂), natural gas 13A (LNG), 100% methane (CH ₄), 100% propane (C ₃ H ₈), 100% butane (C ₄ H ₁₀) Gas must be dry and not contain corrosive components (chlorine, sulfur, acid). The gas must also be clean, not containing dust or oil mist.			
Control	Range	1 to 100% FS (see "Gas type and control range" table (page 7-11))			
	Valve output update cycle	5ms			
	Response (at standard differential pressure)	Within 0.3s at setting ±2% FS (typ.) (Control starts from the fully closed status or the setting is changed during control.)			
	Accuracy (at standard temperature and differential pressure, Q: flow rate)	*2 (1) ±1% FS (50% FS < Q ≤ 100% FS) (2) ±0.5% FS (0% FS ≤ Q ≤ 50% FS)			
	Repeatability (Q: flow rate)	(1) ±0.5% FS (50% FS < Q ≤ 100% FS) (2) ±0.25% FS (0% FS ≤ Q ≤ 50% FS)			
	Temperature characteristics (with air)	0.06% FS max. per 1°C			0.08% FS max. per 1°C
	Pressure characteristics (with air)	0.4% FS max. per 100kPa		0.2% FS max. per 100kPa	
Pressure	Standard differential pressure	*3	150kPa (inlet pressure: 150kPa (gauge), outlet pressure: 0kPa (gauge))	200kPa (inlet pressure: 200kPa (gauge), outlet pressure: 0kPa (gauge))	
	Required differential pressure	*4	5kPa	50kPa	100kPa
	Operating differential pressure range	*5	300kPa max.		
	Allowable inlet pressure	*6	0.5MPa (gauge)		
	Pressure resistance		1MPa (gauge)		
Temperature	Standard operating temperature	*3	+23°C		
	Allowable operating temperature range		-10 to +60°C		
	Allowable storage temperature range		-20 to +70°C		
Humidity	Allowable operating humidity range	10 to 90% RH (condensation not allowed)			
External leaks	Helium leak rate (1/4" VCR connection type)	Within 1 x 10 ⁻⁶ Pa·m ³ /s			
Flow rate setup	Setup method	(1) Key operation (2) External analog input (3) Dedicated loader communications (4) RS-485 communications (3 wire-system)			*7 *8
	Setup resolution	See "Gas type and control range" table (page 7-11).			
	External analog input	Input range: 0 to 5Vdc/1 to 5Vdc/0 to 20mA/4 to 20mA (switchable) Input impedance: 1MΩ±10% (voltage input), 250Ω±10% (current input)			

Item		Model No.	MQV0005	MQV0020	MQV0050 (B,C)
Flow rate display	Display method	7-segment LED 4 digits			
	Setup resolution	See "Gas type and control range" table (page 7-11).			
	Indication accuracy (at standard temperature and differential pressure; Q: flow rate)	(1) $\pm 1\%$ FS ± 1 digit (50% FS < Q \leq 100% FS) (2) $\pm 0.5\%$ FS ± 1 digit (0% FS \leq Q \leq 50% FS)			
Totalizing function	Display range	0.0 to 9,999,999.9L	0 to 99,999,999L	0 to 99,999,999L	
	Display resolution	0.1L	1L	1L	
	Totalized count backup timing	(1) Every 50L (2) Every hour from the previous backup (3) At the time the RUN key is pressed.	(1) Every 200L	(1) Every 500L	
Analog output	Output type	Instantaneous flow rate (PV) output or setting flow rate (SP) output (switchable)			
	Output scale	0 to full-scale flow rate (scale can be changed.)			
	Output range	0 to 5Vdc/1 to 5Vdc/0 to 20mA/4 to 20mA (switchable)			
	Max. output	7Vdc max./128 mA max. (max. output when flow rate exceeds range)			
	Accuracy	$\pm 0.3\%$ FS (Total output accuracy: Indication accuracy $\pm 0.3\%$ FS)			
	External load resistance	Voltage output type: 250k Ω min. Current output type: 300 Ω max.			
Alarm/event output	Number of outputs	Alarm output: 1. Event output: 2			
	Output rating	30Vdc, 30mA max. (open collector non-insulated output)			
	Totalized pulse output width	100ms $\pm 10\%$ (when pulse output is selected in the function setup)			
	Totalized pulse output rate	0.1L/1 pulse	1L/1 pulse	1L/1 pulse	
External switching input	Input type, number of inputs	External 3-way switching input (OPEN/GND/5V): 1 External contact input (2-way switching): 3			
	Required circuit type	Non-voltage contact, or open collector			
	Contact OFF terminal voltage	External 3-way switching input: 2.5 ± 0.5 V External contact input: 2.8 ± 0.5 V			
	Contact ON terminal current	Approx. 0.5mA (current flowing to contact)			
	Allowable ON contact resistance	250 Ω max.			
	Allowable OFF contact resistance	100k Ω min.			
	Allowable ON residual voltage	1.0V max. (open collector type)			
	Allowable OFF leakage current	50 μ A max. (open collector type)			
Reference voltage output	Output rating	5.0Vdc $\pm 5\%$, 5mA max.			
	Application	Reference voltage of flow rate setting voltage and 5V input of external 3-way switching input			
Communications	Mode	Dedicated loader communications RS-485 communications (3-wire system)			*7 *8
	Transmission speed	2400, 4800, 9600, 19200, 38400 bps (loader communications: 19200bps only)			
Power	Rating	24Vdc, current consumption: 300mA max.			
	Allowable power voltage range	21.6 to 26.4Vdc (ripple 5% max.)			
	Isolation	The power circuit is isolated from the input/output circuit.			
Material of gas-contacting parts		SUS316, Teflon, Fluororubber			
Connection method		9/16-18UNF, Rc 1/4", 1/4" Swagelok, 1/4" VCR			
Mounting orientation		Horizontal. Be sure that display surface does not face down.			
Mass		Approx. 1.2kg			
Applicable standards		EN61326-2-3: 2013, EN61326-1: 2013 (To be used in an industrial electromagnetic environment) During EMC testing, the reading or output may fluctuate by the equivalent of $\pm 10\%$ FS.			

● MQV0050(J, K)/0200/0500

Item		Model No.	MQV0050(J, K)	MQV0200	MQV0500
Valve type			Proportional solenoid valve		
Valve operation			Normally closed when de-energized (N.C.)		
Standard full-scale flow rate		*1	50.0 L/min(standard)	200 L/min(standard)	500 L/min(standard)
Gas types			Air/nitrogen (N ₂), oxygen (O ₂), argon (Ar), carbon dioxide (CO ₂), natural gas 13A (LNG), 100% methane (CH ₄), 100% propane (C ₃ H ₈), 100% butane (C ₄ H ₁₀) Gas must be dry and not contain corrosive components (chlorine, sulfur, acid). The gas must also be clean, not containing dust or oil mist.		
Control	Range		1 to 100% FS (see table "Gas type and control range" (page 7-11))		
	Valve output update cycle		5ms		
	Response (at standard differential pressure)		Within 0.7s at setting ±2% FS (typ.) (Control starts from the fully closed status or the setting is changed during control.)		
	Accuracy (at standard temperature and differential pressure, Q: flow rate)	*2	(1) ±1.5% FS (80% FS < Q ≤ 100% FS) (2) ±1% FS (40% FS < Q ≤ 80% FS) (3) ±0.5% FS (0% FS ≤ Q ≤ 40% FS)		
	Repeatability (Q: flow rate)		(1) ±0.75% FS (80% FS < Q ≤ 100% FS) (2) ±0.5% FS (40% FS < Q ≤ 80% FS) (3) ±0.25% FS (0% FS ≤ Q ≤ 40% FS)		
	Temperature characteristics (with air)		0.08% FS max. per 1°C		
	Pressure characteristics (with air)		0.2% FS max. per 100kPa		
Pressure	Standard differential pressure	*3	20kPa (inlet pressure: 20kPa (gauge), outlet pressure: 0kPa (gauge))	200kPa (inlet pressure: 200kPa (gauge), outlet pressure: 0kPa (gauge))	
	Required differential pressure	*4	10kPa	100kPa	150kPa
	Operating differential pressure range (T: operating temperature)	*5	100kPa max.	300kPa max. (-10°C ≤ T ≤ 40°C) 180kPa max. (40°C < T ≤ 60°C) Power voltage: 24Vdc *9	300 kPa max. (-10°C ≤ T ≤ 35°C) 240 kPa max. (35°C < T ≤ 50°C) Power voltage: 24Vdc *9
	Allowable inlet pressure	*6	0.5MPa (gauge)		
	Pressure resistance		1MPa (gauge)		
Temperature	Standard operating temperature	*3	+23°C		
	Allowable operating temperature range		-10 to +60°C		-10 to +50°C
	Allowable storage temperature range		-20 to +70°C		
Humidity	Allowable operating humidity range		10 to 90% RH (condensation not allowed)		
External leaks	Helium leak rate (3/8" VCR connection type)		Within 1 x 10 ⁻⁶ Pa·m ³ /s		
Flow rate setup	Setup method		(1) Key operation (2) External analog input (3) Dedicated loader communications (4) RS-485 communications (3 wire-system)		*7 *8
	Setup resolution		See "Gas type and control range" table (page 7-11).		
	External analog input		Input range: 0 to 5Vdc/1 to 5Vdc/0 to 20mA/4 to 20mA (switchable) Input impedance: 1MΩ±10% (voltage input), 250Ω±10% (current input)		

Item		Model No.	MQV0050(J, K)	MQV0200	MQV0500
Flow rate display	Display method	7-segment LED, 4 digits			
	Setup resolution	See "Gas type and control range" table (page 7-11).			
	Indication accuracy (at standard temperature and differential pressure; Q: flow rate)	(1) $\pm 1.5\%$ FS ± 1 digit (80% FS < Q \leq 100% FS) (2) $\pm 1.0\%$ FS ± 1 digit (40% FS < Q \leq 80% FS) (3) $\pm 0.5\%$ FS ± 1 digit (0% FS \leq Q \leq 40% FS)			
Totalizing function	Display range	0.001 to 99,999.999m ³	0.01 to 999,999.99m ³	0.0 to 9,999,999.9m ³	
	Display resolution	0.001m ³	0.01m ³	0.01m ³	
	Totalized count backup timing	(1) Every 0.5m ³ (2) Every hour from the previous backup (3) At the time the RUN key is pressed.	(1) Every 2m ³	(1) Every 5m ³	
Analog output	Output type	Instantaneous flow rate (PV) output or setting flow rate (SP) output (switchable)			
	Output scale	0 to full-scale flow rate (scale can be changed.)			
	Output range	0 to 5Vdc/1 to 5Vdc/0 to 20mA/4 to 20mA (switchable)			
	Max. output	7Vdc max./28 mA max. (max. output when flow rate exceeds range)			
	Accuracy	Total output accuracy $\pm 0.3\%$ FS Indication accuracy $\pm 0.3\%$ FS			
	External load resistance	Voltage output type: 250k Ω min. Current output type: 300 Ω max.			
Alarm/event output	Number of outputs	Alarm output: 1, Event output: 2			
	Output rating	30Vdc, 30mA max. (open collector non-insulated output)			
	Totalized pulse output width	100ms $\pm 10\%$ (when pulse output is selected in the function setup)			
	Totalized pulse output rate	0.001m ³ /1 pulse	0.01m ³ /1 pulse	0.01m ³ /1 pulse	
External switching input	Input type, number of inputs	External 3-way switching input (OPEN/GND/5V): 1 External contact input (2-way switching): 3			
	Required circuit type	Non-voltage contact, or open collector			
	Contact OFF terminal voltage	External 3-way switching input: 2.5 ± 0.5 V External contact input: 2.8 ± 0.5 V			
	Contact ON terminal current	Approx. 0.5mA (current flowing to contact)			
	Allowable ON contact resistance	250 Ω max.			
	Allowable OFF contact resistance	100k Ω min.			
	Allowable ON residual voltage	1.0V max. (open collector type)			
	Allowable OFF leakage current	50 μ A max. (open collector type)			
Reference voltage output	Output rating	5.0Vdc $\pm 5\%$, 5mA max.			
	Application	Reference voltage of flow rate setting voltage and 5V input of external 3-way switching input			
Communications	Mode	Dedicated loader communications RS-485 communications (3-wire system)			*7 *8
	Transmission speed	2400, 4800, 9600, 19200, 38400 bps (loader communications: 19200bps only)			
Power	Rating	24Vdc, current consumption: 400mA max.			24Vdc current consumption: 500mA max.
	Allowable power voltage range (T: operating temperature)	21.6 to 26.4Vdc (ripple 5% max.)	(1) 21.6 to 26.4Vdc (-10°C \leq T \leq 40°C) (2) 23.5 to 26.4Vdc (40°C < T \leq 60°C) (ripple 5% max.)	(1) 21.6 to 26.4Vdc (-10°C \leq T \leq 35°C) (2) 23.5 to 26.4Vdc (35°C < T \leq 50°C) (ripple 5% max.)	
	Isolation	The power circuit is isolated from the input/output circuit.			
Material of gas-contacting parts		SUS316, Teflon, Fluororubber			
Connection method		3/4-16UNF, Rc 1/2", 1/2" Swagelok, 3/8" VCR			
Mounting orientation		Horizontal. Be sure that display surface does not face down.			
Mass		Approx. 3.5kg			
Applicable standards		EN61326-2-3: 2013, EN61326-1: 2013 (To be used in an industrial electromagnetic environment) During EMC testing, the reading or output may fluctuate by the equivalent of $\pm 10\%$ FS.			

- *1. The notations mL/min (standard) and the L/min (standard) refer to volumetric flow rate per minute after conversion to 20°C , 1 atmosphere. The reference temperature can also be changed to 0°C, 25°C or 35°C in the ζ -1-9 flow rate display unit selection. The controllable flow rate range varies according to the gas type. See “Gas type and control range” table.
- *2. This table is accurate for air/nitrogen and oxygen (for oxygen model). For details about accuracy for other gas types, contact the azbil Group.
- *3. Temperature and pressure mean those during calibration.
- *4. Differential pressure required for obtaining full-scale flow rate. (Outlet pressure=0kPa (gauge))
- *5. Operation is possible even below the required differential pressure, but the controllable flow rate range becomes narrower. See “Relationship between differential pressure and flow rate”
- *6. For the advisability of using an inlet pressure of 0.5 MPa (gauge) or more, contact the azbil Group.
- *7. The MLP100 Loader Package for the MQV is required (sold separately).
- *8. Only models with RS-485 communications option.
- *9. The maximum operating differential pressure of the MQV0200/0500 may also vary depending on the power voltage. For details, see the graph below.

Relationship between power voltage and maximum operating differential pressure in MQV0200/0500

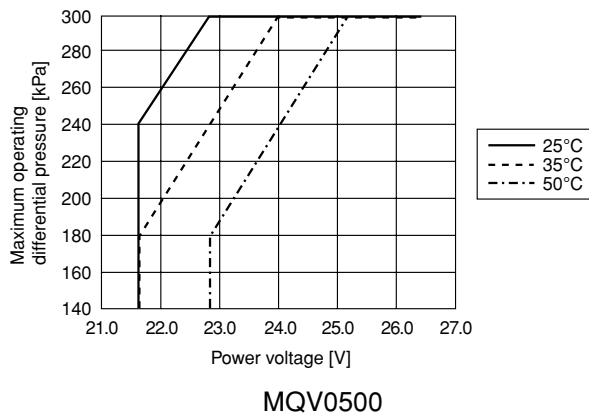
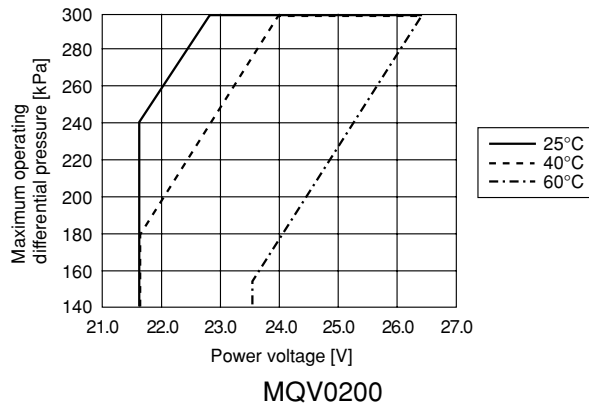

! Handling Precautions

- If this device is operated with a differential pressure exceeding the maximum operating differential pressure shown in the graph on the preceding page, the voltage to the valve becomes insufficient and the target flow rate cannot be obtained. Additionally, even if the voltage does not become insufficient, flow rate hunting may occur if the operating differential pressure exceeds 300kPa. Always operate this device with a differential pressure less than 300kPa.

■ Gas type and control range

The controllable flow rate range may vary depending on the type of gas.

For details, see the tables below.

Model No. Gas type	MQV9005		MQV9020	
	Control flow rate range mL/min(standard)	Setup/display resolution mL/min(standard)	Control flow rate range L/min(standard)	Setup/display resolution L/min(standard)
Air/nitrogen	0.10 to 5.00	0.02	0.2 to 20.0	0.1
Oxygen	0.10 to 5.00	0.02	0.2 to 20.0	0.1
Argon	0.10 to 5.00	0.02	0.2 to 20.0	0.1

Model No. Gas type	MQV9200		MQV9500		MQV0002	
	Control flow rate range mL/min(standard)	Setup/display resolution mL/min(standard)	Control flow rate range L/min(standard)	Setup/display resolution L/min(standard)	Control flow rate range L/min(standard)	Setup/display resolution L/min(standard)
Air/nitrogen	2 to 200	1	0.004 to 0.500	0.002	0.02 to 2.00	0.01
Oxygen	2 to 200	1	0.004 to 0.500	0.002	0.02 to 2.00	0.01
Argon	2 to 200	1	0.004 to 0.500	0.002	0.02 to 2.00	0.01
Carbon dioxide	1.0 to 120.0	0.5	0.003 to 0.300	0.001	0.010 to 1.200	0.005
Natural gas 13A (LNG) (1)	2 to 200	1	0.004 to 0.500	0.002	0.02 to 1.60	0.01
Natural gas 13A (LNG) (2)	2 to 200	1	0.004 to 0.500	0.002	0.02 to 2.00	0.01
100% methane	2 to 200	1	0.004 to 0.500	0.002	0.02 to 2.00	0.01
100% propane	0.6 to 60.0	0.2	0.002 to 0.160	0.001	0.006 to 0.600	0.002
100% butane	0.4 to 50.0	0.2	(1.0 to 120.0)*	(0.5)*	0.004 to 0.400	0.002

Model No. Gas type	MQV0005		MQV0020		MQV0050(B, C)	
	Control flow rate range L/min(standard)	Setup/display resolution L/min(standard)	Control flow rate range L/min(standard)	Setup/display resolution L/min(standard)	Control flow rate range L/min(standard)	Setup/display resolution L/min(standard)
Air/nitrogen	0.04 to 5.00	0.02	0.2 to 20.0	0.1	0.4 to 50.0	0.2
Oxygen	0.04 to 5.00	0.02	0.2 to 20.0	0.1	0.4 to 50.0	0.2
Argon	0.04 to 5.00	0.02	0.2 to 20.0	0.1	0.4 to 50.0	0.2
Carbon dioxide	0.03 to 3.00	0.01	0.10 to 12.00	0.05	0.3 to 30.0	0.1
Natural gas 13A (LNG) (1)	0.04 to 5.00	0.02	0.2 to 20.0	0.1	0.4 to 50.0	0.2
Natural gas 13A (LNG) (2)	0.04 to 5.00	0.02	0.2 to 20.0	0.1	0.4 to 50.0	0.2
100% methane	0.04 to 5.00	0.02	0.2 to 20.0	0.1	0.4 to 50.0	0.2
100% propane	0.02 to 1.60	0.01	0.06 to 6.00	0.02	0.2 to 16.0	0.1
100% butane	0.010 to 1.200	0.005	0.04 to 4.00	0.02	0.10 to 10.00	0.05

Model No. Gas type	MQV0050(J, K)		MQV0200		MQV0500	
	Control flow rate range L/min(standard)	Setup/display resolution L/min(standard)	Control flow rate range L/min(standard)	Setup/display resolution L/min(standard)	Control flow rate range L/min(standard)	Setup/display resolution L/min(standard)
Air/nitrogen	0.4 to 50.0	0.2	2 to 200	1	4 to 500	2
Oxygen	0.4 to 50.0	0.2	2 to 200	1	4 to 500	2
Argon	0.4 to 50.0	0.2	2 to 200	1	4 to 500	2
Carbon dioxide	0.3 to 30.0	0.1	1 to 120	0.5	4 to 400	2
Natural gas 13A (LNG) (1)	0.4 to 50.0	0.2	2 to 200	1	4 to 400	2
Natural gas 13A (LNG) (2)	0.4 to 50.0	0.2	2 to 200	1	4 to 500	2
100% methane	0.4 to 50.0	0.2	2 to 200	1	4 to 500	2
100% propane	0.2 to 16.0	0.1	0.6 to 60.0	0.2	2 to 200	1
100% butane	0.10 to 12.00	0.05	0.4 to 40.0	0.2	2 to 160	1

* When the gas type is set at "100% butane" on the MQV9500, the unit of flow rate display is mL/min.

Note

The setup and display resolutions described above can be improved by reducing the flow rate range using flow rate range setup $\zeta-24$ or $\zeta-25$.

A still higher resolution can be set using the analog setup ($\zeta-03$, #1). For more information, see section 5-4, "Flow Rate Range Change Function and Settings and Display Resolutions After Change of Range" (page 5-17).

Relationship between differential pressure and flow rate

Condition: the valve is fully open in air.

● **MQV9005/9020**

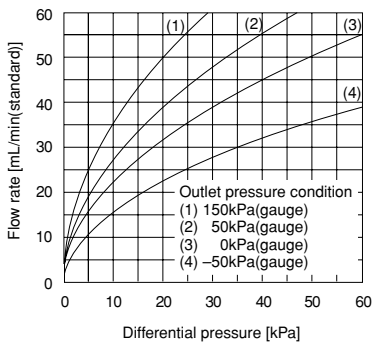

● **MQV9200/9500/0002**

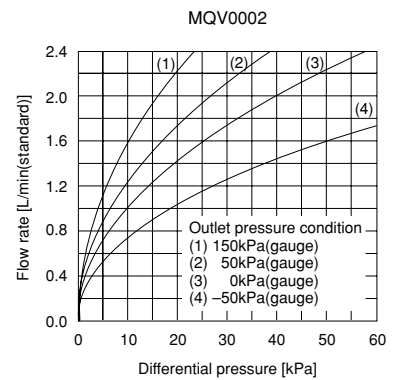
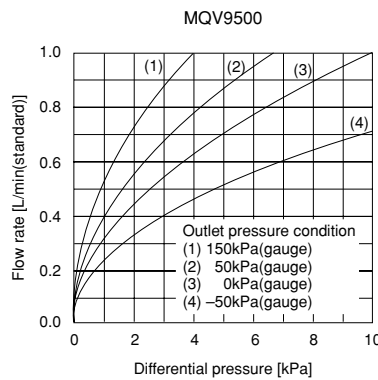
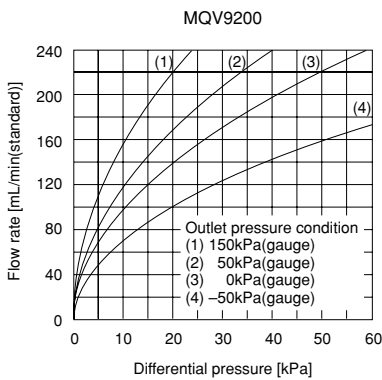

● **MQV0005/0020/0050(B, C)**

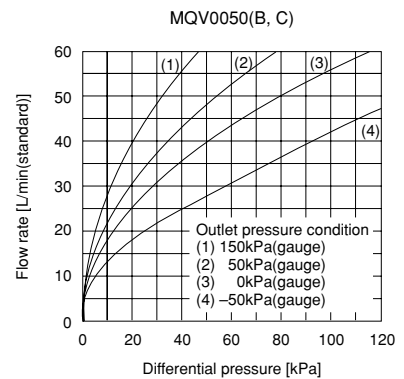
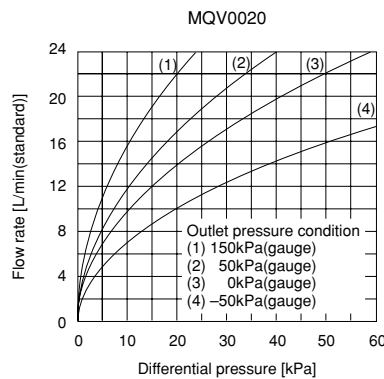
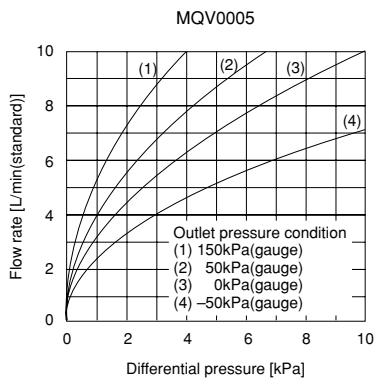

● MQV0050(J, K)/0200/0500

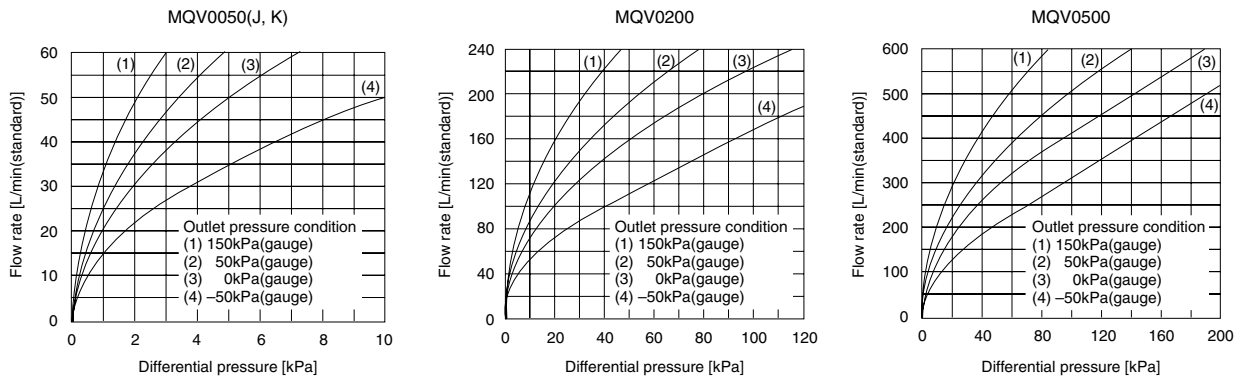

! Handling Precautions

- If the outlet pressure is different from the values graphed on the previous page, calculate the flow rate using the appropriate equation below.

- (1) When $P2 / P1 > 0.53$,

$$Q = C1 \sqrt{(P1 - P2) \times P2}$$
- (2) When $P2 / P1 \leq 0.53$,

$$Q = C2 \cdot P1$$

P1: Inlet absolute pressure [kPa (abs)]

P2: Outlet absolute pressure [kPa (abs)]

(Absolute pressure = gauge pressure + 101.3kPa)

Q: Flow rate [L/min (standard)] ([mL/min (standard)] for MQV9005/9020/9200)

C1 and C2: Constant values by model

- MQV9005: C1= 0.7097, C2=0.4653
- MQV9020: C1= 0.7097, C2=0.4653
- MQV9200: C1= 3.123, C2=1.559
- MQV9500: C1= 0.03123, C2=0.01559
- MQV0002: C1= 0.03123, C2=0.01559
- MQV0005: C1= 0.3123, C2=0.1559
- MQV0020: C1= 0.3123, C2=0.1559
- MQV0050(B, C): C1= 0.5529, C2=0.2760
- MQV0050(J, K): C1= 2.212, C2=1.104
- MQV0200: C1= 2.212, C2=1.104
- MQV0500: C1= 4.115, C2=2.054

- When used with the gases other than air, convert the flow rate using the following equation:

$$\text{Flow rate} = \text{Flow rate in air} \div \sqrt{\text{specific gravity of gas to be controlled}}$$

Example: When using the MQV0002 with CO₂, inlet pressure = 10kPa (gauge), and outlet pressure = 0kPa (gauge),
 1.0 L/min (standard) $\div \sqrt{1.53} = 0.81$ L/min (standard)

Specific gravity of standard compatible gas (air is taken as 1.0)

Gas type	Specific gravity
Oxygen	1.11
Argon	1.38
Carbon dioxide	1.53
Natural gas 13A (LNG)	0.64
100% methane	0.56
100% propane	1.56
100% butane	2.08

Relationship between differential pressure and outlet flow rate when valve of MQV0500 is fully closed (air flow under conditions of outlet pressure = 0kPa (gauge))

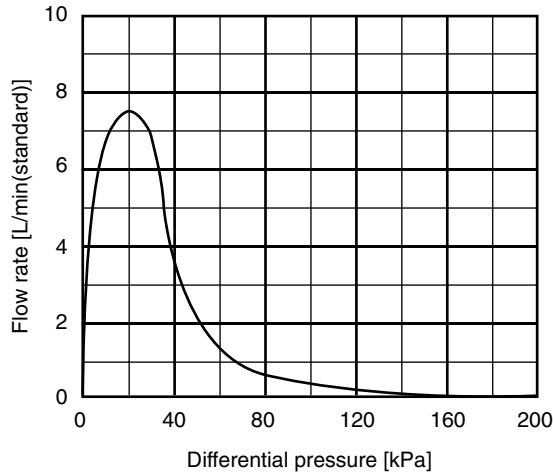

! Handling Precautions

- If this device is used for a gas other than air or if it is operated under conditions different from the outlet pressure, the conversion needs to be made using the equation stated on the previous page.

■ Optional parts (sold separately)

Item	Model No.	Remarks
Cable with dedicated connector	81446681-001	20-wire flat cable 2m (AWG#24)
	81446951-001	20-wire shielded cable 5m (7/0.2mm ²)
AC adapter	81446957-001	Input rating: 100 to 240Vac 50/60Hz 0.4A Output rating: 24Vdc/750mA Operating temperature range: 0 to 40°C
Potentiometer for flow rate setting	81446683-002	5kΩ with digital dial, 10 turns
Front cover for separate display unit	81446858-001	Mask: 1 piece Plate: 1 piece Mounting screws: 2 pieces
Loader Package	MLP100A100	MQV can be configured on a PC. In addition, operating status such as flow rate trends can be monitored on the PC screen.
Rc 1/4" joint	81446834-001	Set of 2 pieces, O-ring attached, oil-inhibited product
Rc 1/2" joint	81446834-002	Set of 2 pieces, O-ring attached, oil-inhibited product
1/4" Swagelok	81446833-001	Set of 2 pieces, O-ring attached, oil-inhibited product
1/2" Swagelok	81446833-002	Set of 2 pieces, O-ring attached, oil-inhibited product
1/4" VCR	81446895-001	Set of 2 pieces, O-ring attached, oil-inhibited product
3/8" VCR	81446895-002	Set of 2 pieces, O-ring attached, oil-inhibited product

! Handling Precautions

- The old type AC adapter, 81446682-001 (15Vdc, 350mA), cannot be used for this device.

External dimensions

Models with integrated display

MQV9005B/9020B/9200B/9500B/0002B/0005B/0020B/0050B

Unit: mm

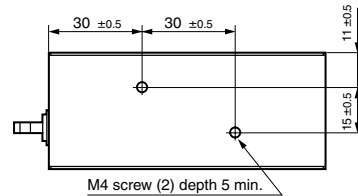
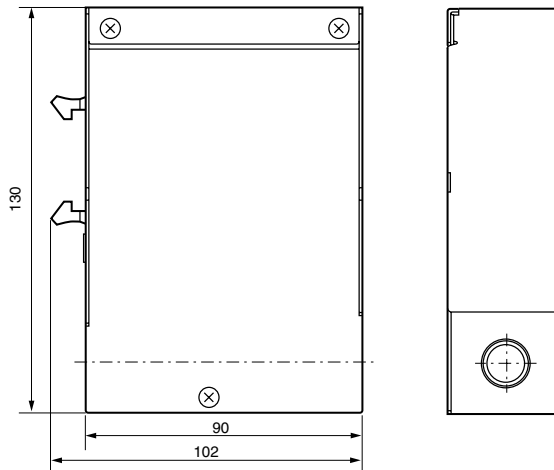
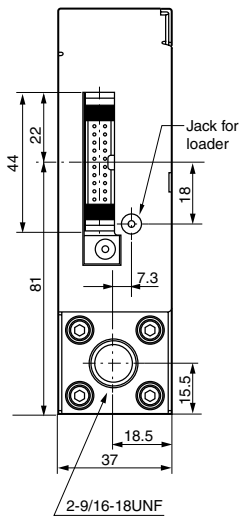
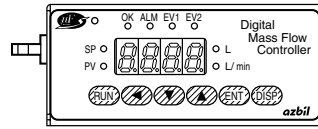

9/16-18UNF connection type

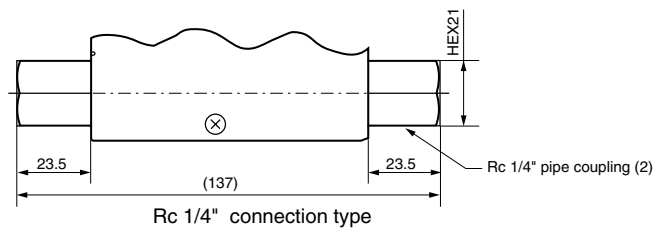

Rc 1/4" connection type

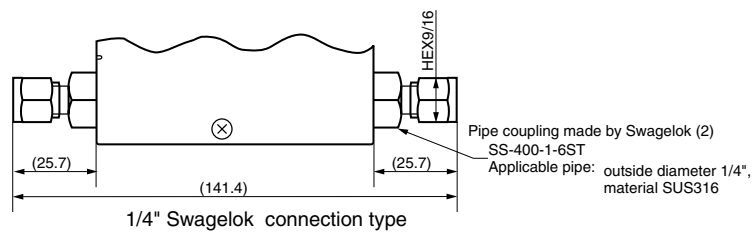

1/4" Swagelok connection type

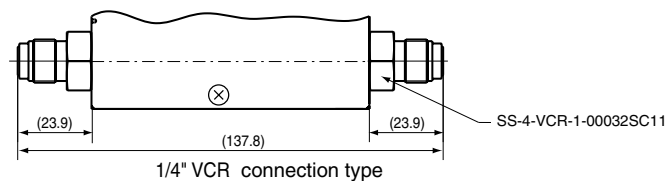

1/4" VCR connection type

● Models with integrated display
MQV0050J/0200J/0500J

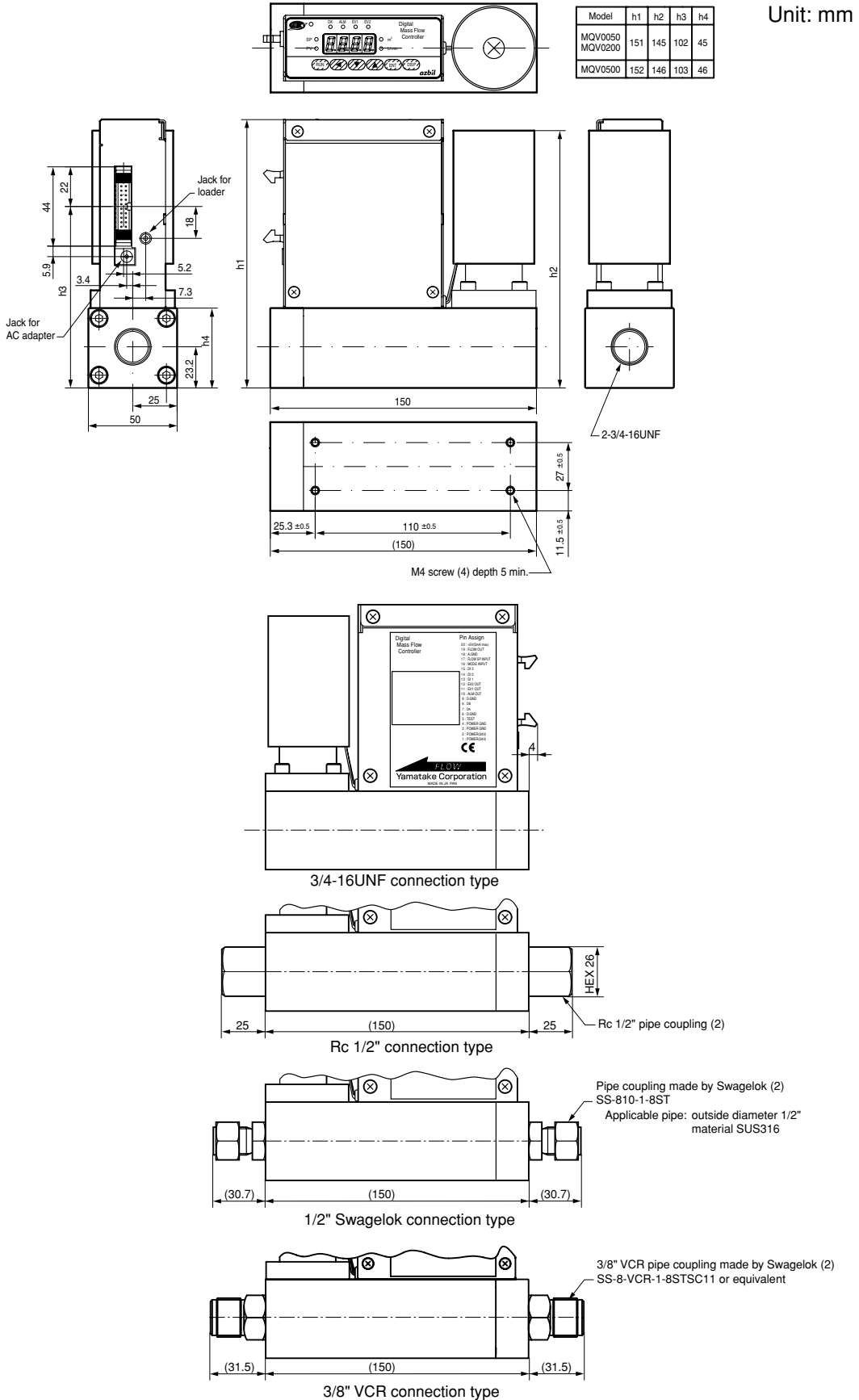

● Model with separate display
 MQV9005C/9020C/9200C/9500C/0002C/0005C/0020C/0050C

- Body

Unit: mm

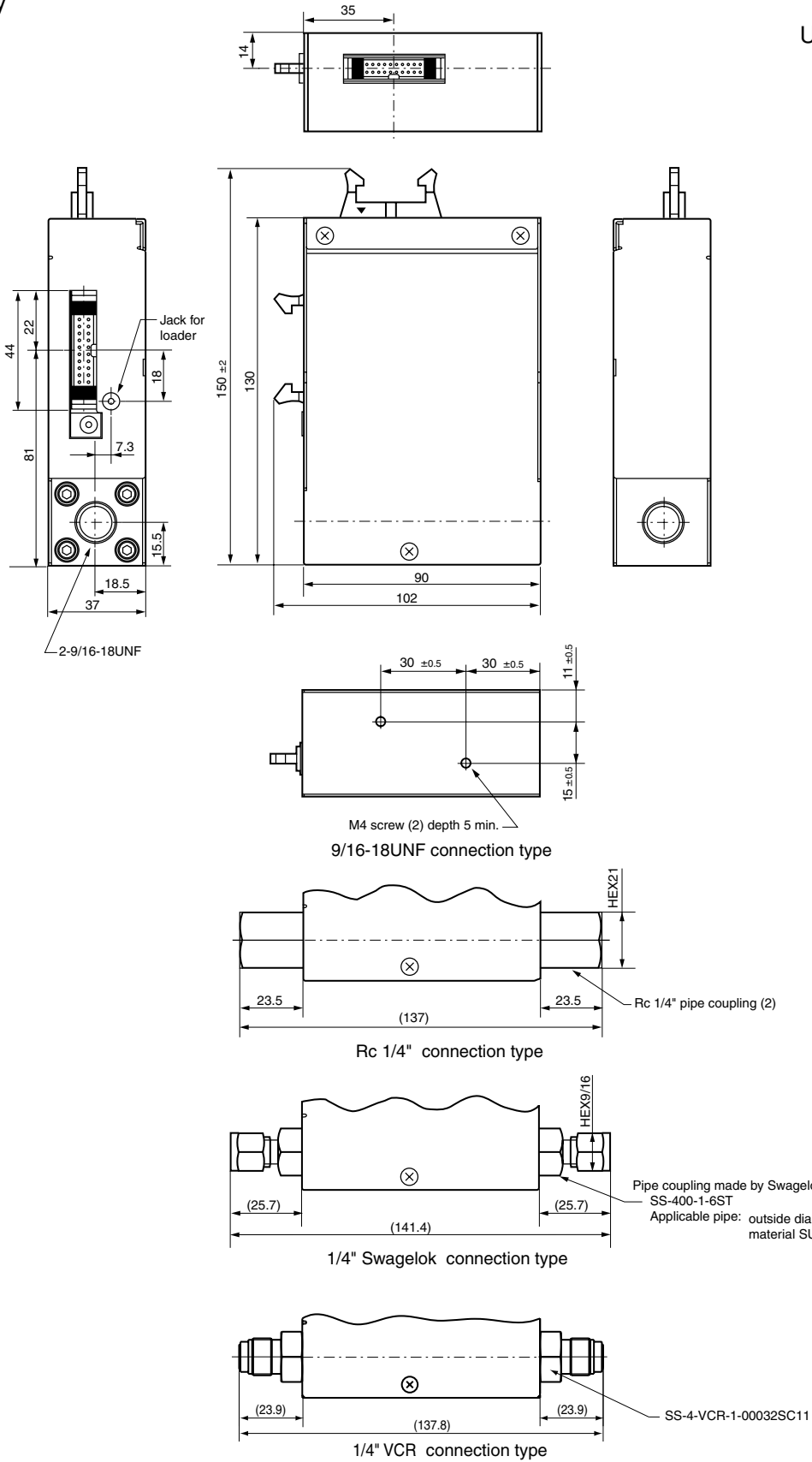

● Model with separate display
MQV0050K/0200K/0500K

- Body

Unit: mm

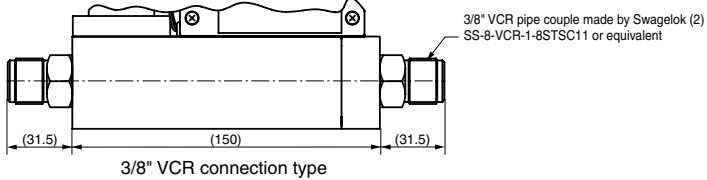
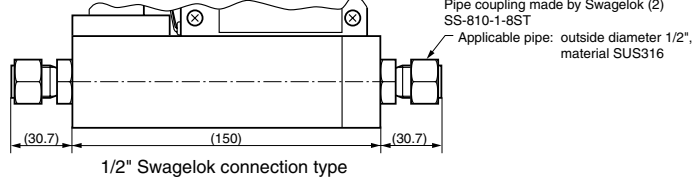
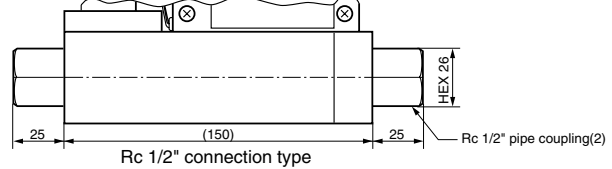
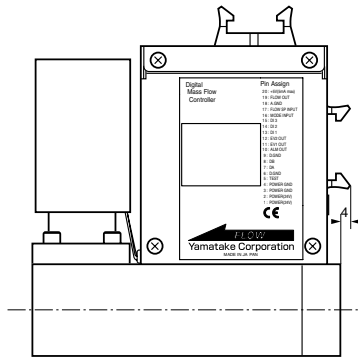
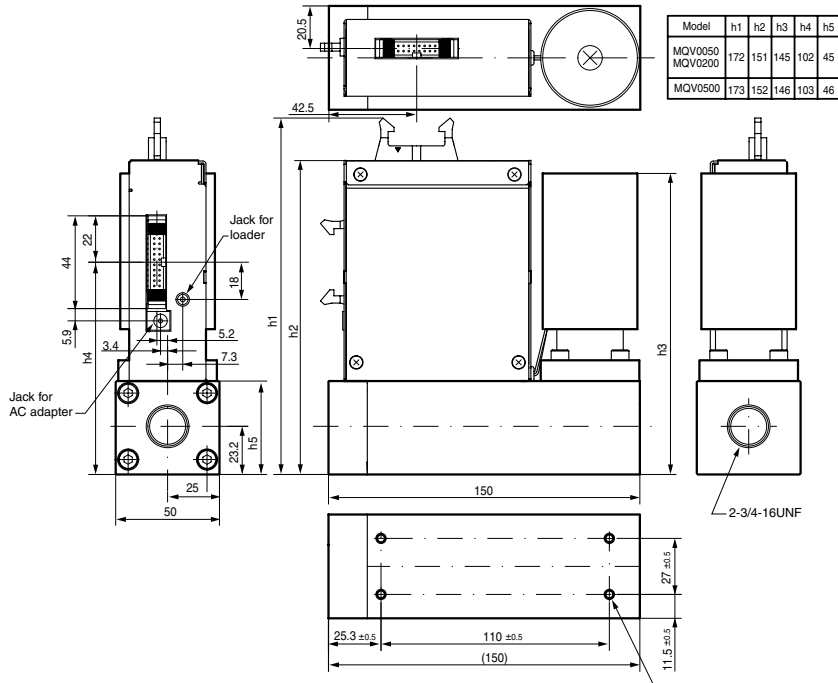

• Separate display unit

Unit: mm

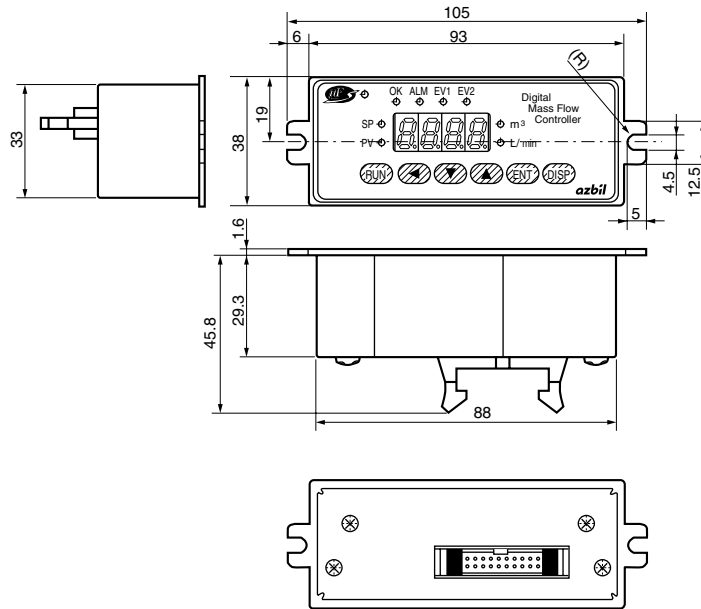

Mounting panel cutout dimensions (recommended)

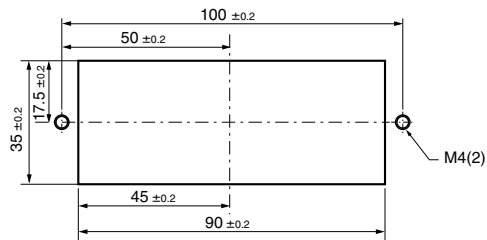

● Cable for connecting display to body

Unit: mm

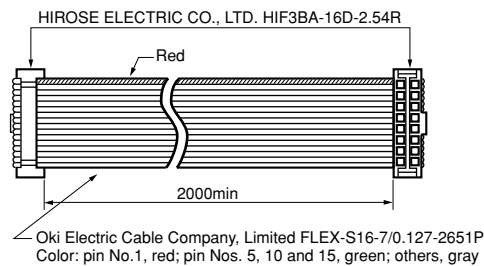

● Front cover for separate display unit 81446858-001

Unit: mm

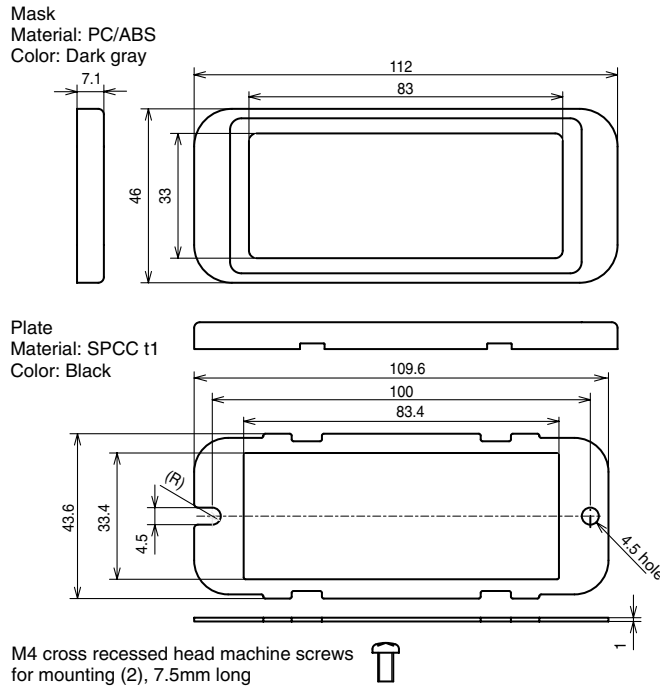

● Cable with dedicated connector

- 20-wire flat cable 81446681-001

Unit: mm

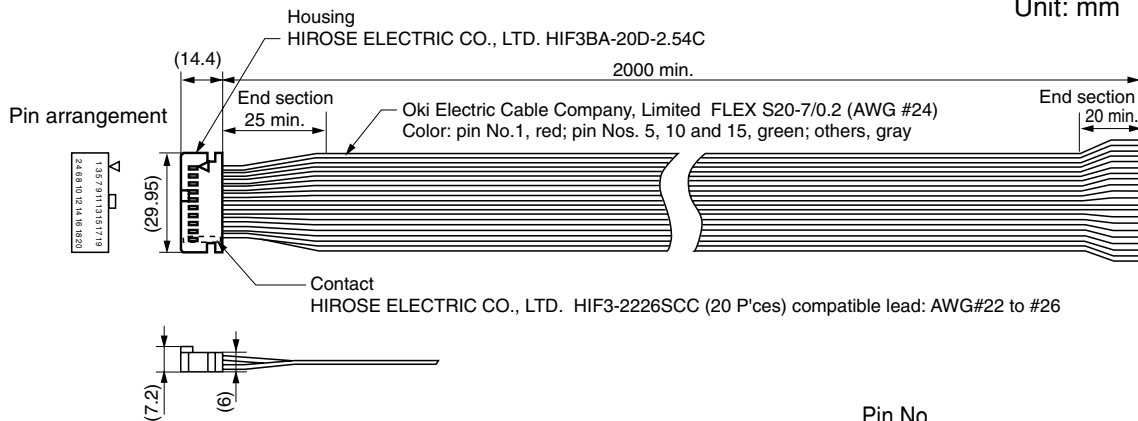

- 20-wire shielded cable 81446951-001

Pin No.

-lead wire color correspondence table

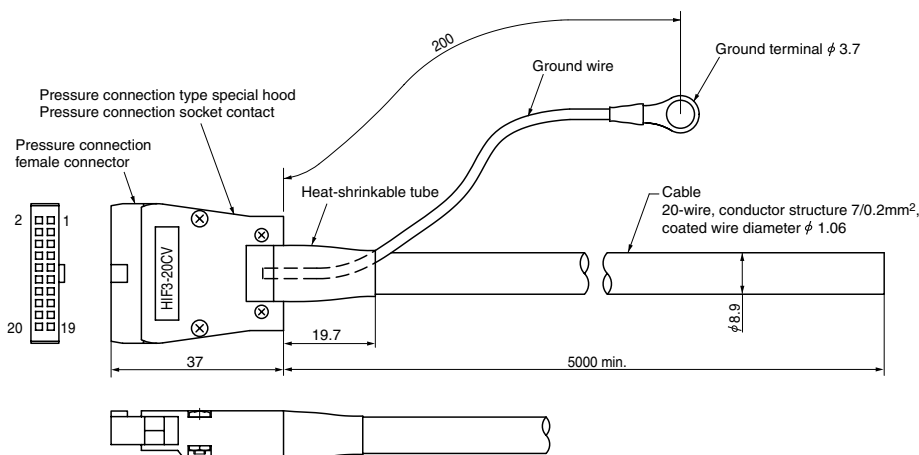

Pin No.	Lead wire
1	Black
2	Black/White
3	Red
4	Red/White
5	Green
6	Green/White
7	Yellow
8	Yellow/White
9	Brown
10	Brown/White
11	Blue
12	Blue/White
13	Grey
14	Grey/White
15	Orange
16	Orange/White
17	Purple
18	Purple/White
19	Bright Green
20	Bright Green/White

● Potentiometer for flow rate setting 81446683-002

- Digital dial

- Potentiometer

Unit: mm

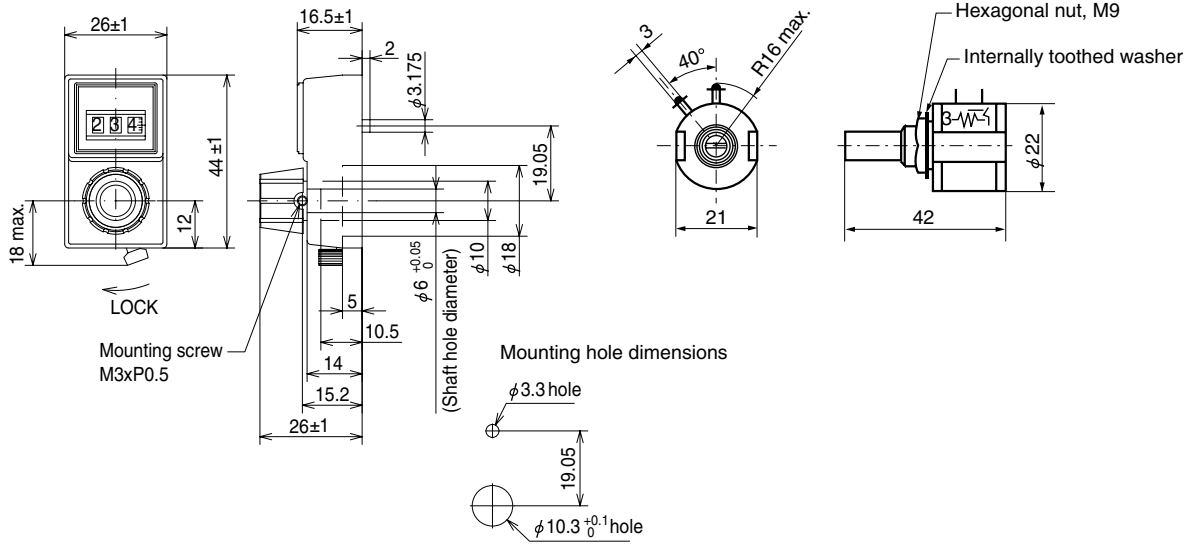

● AC adapter 81446957-001

Unit: mm

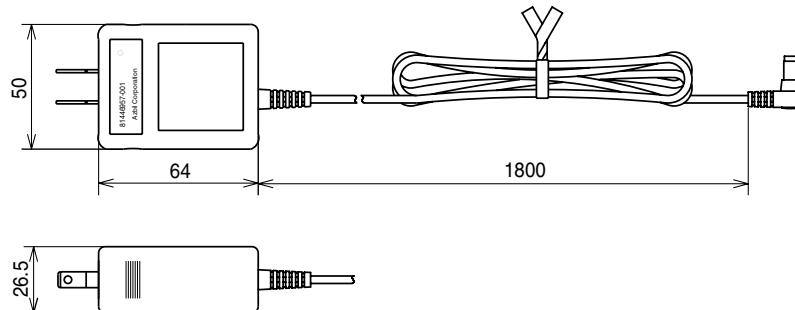

Revision History

Printed date	Manual Number	Edition	Revised pages	Description
Apr. 2006	CP-SP-1204E	1st Edition		
Sep. 2010		2nd Edition	i ii, iii, iv, 3-1, 3-6, 4-1 1-1 1-6, 1-7, 5-11, 5-14 3-12, 6-1 7-14 7-18 7-2 to 7-4, 7-11 to 7-13	Examples changed. Cautions changed and added. MVQ9005 added to Features. MVQ9005/9020 added. Handling Precautions added. AC adapter output rating changed. MLP100A Loader Package added to optional parts. Pin No. lead wire color correspondence table added. MVQ9005/9020 added to specifications.
July 2011		3rd Edition	1-8, 1-9 4-1 5-9 5-14 5-17 6-2 7-2 to 7-9 7-14	The model designation CMQ-V was changed to MQV. Change in note *2. Handling Precautions changed. Tables in notes 2 and 3 changed. Addition to note 14. MVQ9005/9020 added. Explanation added. Changes and additions to the Troubleshooting guide. Specifications changed. MQV9005/9020 added to the table. 6 parts added to Optional parts section.
Sep. 2011		4th Edition	ii, v, 1-2, 1-3 7-10	Contact information for inquiries was changed.
Apr. 2012		5th Edition		Company name changed.
Sep. 2017		6th Edition	7-3, 7-5, 7-7, 7-9 End of the manual	The discription was added in "Applicable standards" section. AAS-511A-014-09

Terms and Conditions

We would like to express our appreciation for your purchase and use of Azbil Corporation's products. You are required to acknowledge and agree upon the following terms and conditions for your purchase of Azbil Corporation's products (system products, field instruments, control valves, and control products), unless otherwise stated in any separate document, including, without limitation, estimation sheets, written agreements, catalogs, specifications and instruction manuals.

1. Warranty period and warranty scope

1.1 Warranty period

Azbil Corporation's products shall be warranted for one (1) year from the date of your purchase of the said products or the delivery of the said products to a place designated by you.

1.2 Warranty scope

In the event that Azbil Corporation's product has any failure attributable to azbil during the aforementioned warranty period, Azbil Corporation shall, without charge, deliver a replacement for the said product to the place where you purchased, or repair the said product and deliver it to the aforementioned place.

Notwithstanding the foregoing, any failure falling under one of the following shall not be covered under this warranty:

- (1) Failure caused by your improper use of azbil product (noncompliance with conditions, environment of use, precautions, etc. set forth in catalogs, specifications, instruction manuals, etc.);
- (2) Failure caused for other reasons than Azbil Corporation's product;
- (3) Failure caused by any modification or repair made by any person other than Azbil Corporation or Azbil Corporation's subcontractors;
- (4) Failure caused by your use of Azbil Corporation's product in a manner not conforming to the intended usage of that product;
- (5) Failure that the state-of-the-art at the time of Azbil Corporation's shipment did not allow Azbil Corporation to predict; or
- (6) Failure that arose from any reason not attributable to Azbil Corporation, including, without limitation, acts of God, disasters, and actions taken by a third party.

Please note that the term "warranty" as used herein refers to equipment-only-warranty, and Azbil Corporation shall not be liable for any damages, including direct, indirect, special, incidental or consequential damages in connection with or arising out of Azbil Corporation's products.

2. Ascertainment of suitability

You are required to ascertain the suitability of Azbil Corporation's product in case of your use of the same with your machinery, equipment, etc. (hereinafter referred to as "Equipment") on your own responsibility, taking the following matters into consideration:

- (1) Regulations and standards or laws that your Equipment is to comply with.
- (2) Examples of application described in any documents provided by Azbil Corporation are for your reference purpose only, and you are required to check the functions and safety of your Equipment prior to your use.
- (3) Measures to be taken to secure the required level of the reliability and safety of your Equipment in your use

Although azbil is constantly making efforts to improve the quality and reliability of Azbil Corporation's products, there exists a possibility that parts and machinery may break down.

You are required to provide your Equipment with safety design such as fool-proof design, *1 and fail-safe design*2 (anti-flame propagation design, etc.), whereby preventing any occurrence of physical injuries, fires, significant damage, and so forth. Furthermore, fault avoidance,*3 fault tolerance,*4 or the like should be incorporated so that the said Equipment can satisfy the level of reliability and safety required for your use.

*1. A design that is safe even if the user makes an error.

*2. A design that is safe even if the device fails.

*3. Avoidance of device failure by using highly reliable components, etc.

*4. The use of redundancy.

3. Precautions and restrictions on application

Azbil Corporation's products other than those explicitly specified as applicable (e.g. azbil Limit Switch For Nuclear Energy) shall not be used in a nuclear energy controlled area (radiation controlled area).

Any Azbil Corporation's products shall not be used for/with medical equipment.

The products are for industrial use. Do not allow general consumers to install or use any Azbil Corporation's product.

However, azbil products can be incorporated into products used by general consumers. If you intend to use a product for that purpose, please contact one of our sales representatives.

In addition,

you are required to conduct a consultation with our sales representative and understand detail specifications, cautions for operation, and so forth by reference to catalogs, specifications, instruction manual, etc. in case that you intend to use azbil product for any purposes specified in (1) through (6) below.

Moreover, you are required to provide your Equipment with fool-proof design, fail-safe design, anti-flame propagation design, fault avoidance, fault tolerance, and other kinds of protection/safety circuit design on your own responsibility to ensure reliability and safety, whereby preventing problems caused by failure or nonconformity.

- (1) For use under such conditions or in such environments as not stated in technical documents, including catalogs, specification, and instruction manuals
- (2) For use of specific purposes, such as:
 - * Nuclear energy/radiation related facilities
[For use outside nuclear energy controlled areas] [For use of Azbil Corporation's Limit Switch For Nuclear Energy]
 - * Machinery or equipment for space/sea bottom
 - * Transportation equipment
[Railway, aircraft, vessels, vehicle equipment, etc.]
 - * Antidisaster/crime-prevention equipment

- * Burning appliances
 - * Electrothermal equipment
 - * Amusement facilities
 - * Facilities/applications associated directly with billing
- (3) Supply systems such as electricity/gas/water supply systems, large-scale communication systems, and traffic/air traffic control systems requiring high reliability
 - (4) Facilities that are to comply with regulations of governmental/public agencies or specific industries
 - (5) Machinery or equipment that may affect human lives, human bodies or properties
 - (6) Other machinery or equipment equivalent to those set forth in items (1) to (5) above which require high reliability and safety
4. Precautions against long-term use

Use of Azbil Corporation's products, including switches, which contain electronic components, over a prolonged period may degrade insulation or increase contact-resistance and may result in heat generation or any other similar problem causing such product or switch to develop safety hazards such as smoking, ignition, and electrification. Although acceleration of the above situation varies depending on the conditions or environment of use of the products, you are required not to use any Azbil Corporation's products for a period exceeding ten (10) years unless otherwise stated in specifications or instruction manuals.
 5. Recommendation for renewal

Mechanical components, such as relays and switches, used for Azbil Corporation's products will reach the end of their life due to wear by repetitious open/close operations. In addition, electronic components such as electrolytic capacitors will reach the end of their life due to aged deterioration based on the conditions or environment in which such electronic components are used. Although acceleration of the above situation varies depending on the conditions or environment of use, the number of open/close operations of relays, etc. as prescribed in specifications or instruction manuals, or depending on the design margin of your machine or equipment, you are required to renew any Azbil Corporation's products every 5 to 10 years unless otherwise specified in specifications or instruction manuals. System products, field instruments (sensors such as pressure/flow/level sensors, regulating valves, etc.) will reach the end of their life due to aged deterioration of parts. For those parts that will reach the end of their life due to aged deterioration, recommended replacement cycles are prescribed. You are required to replace parts based on such recommended replacement cycles.
 6. Other precautions

Prior to your use of Azbil Corporation's products, you are required to understand and comply with specifications (e.g., conditions and environment of use), precautions, warnings/cautions/notices as set forth in the technical documents prepared for individual Azbil Corporation's products, such as catalogs, specifications, and instruction manuals to ensure the quality, reliability, and safety of those products.
 7. Changes to specifications

Please note that the descriptions contained in any documents provided by azbil are subject to change without notice for improvement or for any other reason. For inquires or information on specifications as you may need to check, please contact our branch offices or sales offices, or your local sales agents.
 8. Discontinuance of the supply of products/parts

Please note that the production of any Azbil Corporation's product may be discontinued without notice. For repairable products, we will, in principle, undertake repairs for five (5) years after the discontinuance of those products. In some cases, however, we cannot undertake such repairs for reasons, such as the absence of repair parts. For system products, field instruments, we may not be able to undertake parts replacement for similar reasons.
 9. Scope of services

Prices of Azbil Corporation's products do not include any charges for services such as engineer dispatch service. Accordingly, a separate fee will be charged in any of the following cases:

 - (1) Installation, adjustment, guidance, and attendance at a test run
 - (2) Maintenance, inspection, adjustment, and repair
 - (3) Technical guidance and technical education
 - (4) Special test or special inspection of a product under the conditions specified by you

Please note that we cannot provide any services as set forth above in a nuclear energy controlled area (radiation controlled area) or at a place where the level of exposure to radiation is equivalent to that in a nuclear energy controlled area.

azbil

Azbil Corporation
Advanced Automation Company

1-12-2 Kawana, Fujisawa
Kanagawa 251-8522 Japan

URL: <http://www.azbil.com>

Specifications are subject to change without notice. (09)

1st edition: Apr. 2006
6th edition: Sep. 2017 (F)