

Advanced Ultraviolet Burner Controller AUR300C, AUR350C

Overview

The AUR300C is a burner controller with a dynamic self-checking function and is used in combination with the AUD300C or AUD500C Advanced Ultraviolet Flame Detector.

This AUR300C controls the built-in flame relay while checking if any malfunction has occurred in the UV detector or the AUR300C by driving the shutter of the UV detector.

If the detector or amplifier circuit fails for any reason, the AUR300C is not automatically energized and secures the safety of the system.

Features

- When any abnormality exists at the start of operation, the start-check relay is not energized, ensuring safety by not generating a signal to the main valve or flame output.
- Operation status can be confirmed by LED displays (power, shutter, start check and flame).
- Flame signal output (0 to 5Vdc) is provided as a standard function. This is useful for burner adjustment and flame status control.
- A special loader (Smart Loader Package) for configuring the AUR350C from a PC is available (for the AUR350 only).
- The operation of the K3 relay (ON when an event* occurs, when flame voltage high or low limit is exceeded, or when maintenance cycle is due; or synchronous operation with relays K1 or K2) can be specified using the Smart Loader Package (with the AUR350 only).



AUR300



AUR350

- With the RS-485 communication function, monitored trend data (flame voltage, shutter cycle, K1–K3 relay operation), maintenance data, and playback data (event history) can be displayed on a PC using the Smart Loader Package (with the AUR350 only).

* In the case of the AUR350C, false flame, false discharge, frame ground short circuit, flame voltage drop, etc., are called events. The various settings are preset.

■ Precautions for equipment instrumentation

- When designing facilities that include combustion safety equipment, take the safety directives listed below into careful consideration.
- Safety Engineering Directives for Industrial Heating Furnace Combustion Equipment (Health, Labor and Welfare Ministry)
- General Safety Code for Industrial Combustion Furnaces (= JIS B 8415)
- Safety Engineering Directives for Industrial Gas Combustion Equipment (The Japan Gas Association)
- Safety Guidelines for Gas Boiler Combustion Equipment (The Japan Gas Association)

■ Important safety points

1. Directly connect the load to this device.
2. Structure the interlock so that power to the load is directly turned off.
3. Use the start check circuit during startup (do not short out the start contact input).
4. Do not make a manual operation circuit or other bypass circuit for any load.
5. Use redundant shutoff for both the main valve and pilot valve.

■ Precautions for system design

Use an external circuit for the purge function (this device does not have a purge function).

Specifications

• General specifications

Item	Description
Model	AUD300, AUD500
Flame failure response time (3 V flame voltage)	Nominal 1.5 s (max. 2 s), Nominal 3 s (max. 4 s) (selectable by model number)
Flame voltage output	DC 0~5 V
Flame voltage range (at rated voltage, room temp, and humidity)	Flame establishment: 1.5 to 4.0 V dc Flame-out detection: 0.0 to 0.6 V dc
Recommended flame voltage	Stable 2.0 V dc or more
Rated power supply voltage	100 V ac or 200 V ac at 50/60 Hz
Allowable voltage range	85 to 110 % of rated power supply voltage
Power consumption	10 W max. (with AUD300C/500C)
Dielectric strength	1500 V ac 50/60 Hz 1 min or 1800 V ac 50/60 Hz 1 s Application points: Between ground and primary terminals 1 to 8 units (except 9 to 14)
Insulation resistance	100 MΩ min. by a 500 V dc megger Measurement points: Between ground and primary terminals 1 to 8 units (except 9 to 14)
Induced thunderbolt surge	10 kV, 1.2/50μs (JEC-187: 75Ω min. surge impedance) The surge absorber listed hereunder must be connected between the power supply terminal (No.1 terminal) and the ground. Recommended surge absorber: Part No. 83968019-001
Service life	7 years or 100,000 cycles (operation cycles of each relay)
Ambient temperature	-20~+60°C
Storage temperature	-20~+70°C
Ambient humidity	90 % RH at 40°C max. (without condensation)
Vibration resistance	4.9 m/s ² max., 10 to 55 Hz for 2 hours each in X, Y and Z directions
Mounting posture	Wall mounting (vertical or horizontal mounting)
Color	White
Mass	Approx. 1.2 kg

• Communication specifications (only AUR350C)

Item	Description
Communication level	RS-485-compliant
Transmission line connection	Multipoint (up to 15 slave stations for 1 master station)
Communication method	Half-duplex
Synchronization method	Start-stop
Transmission control	Polling-selecting method (CPL communications format)
Maximum cable length	500m
Transmission line	3-wire system
Transmission speed error	0.16%
Terminating resistor	Built in. Do not attach an external resistor.
Transmission speed	2400, 4800, 9600, 19200bps
Data length	8 bits
Stop bits	1 or 2
Parity bit	Even parity or no parity

Model selection table

Basic No.	Function	Flame response	Power supply	Additional processing	Description
AUR300C					Advanced ultraviolet burner controller
AUR350C					Advanced ultraviolet burner controller with communication function
	1				-
		2			Nominal 1.5 s (max. 2 s)
		3			Nominal 3 s (max. 4 s)
			1		100 V ac
			2		200 V ac
				00	No additional processing
				D0	Inspection certificate provided
				T0	Tropicalization treatment applied
				DT	Tropicalization treatment applied and inspection certification provided

AUR300C part names

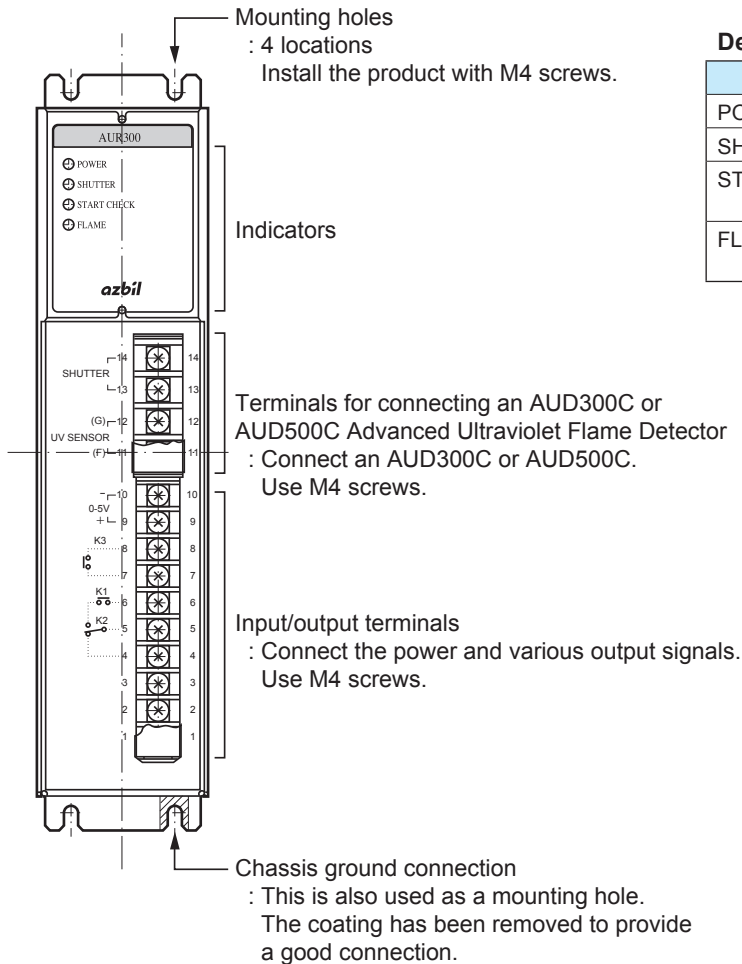

Details on indicators

Name	Color	Description
POWER	Green	Lit when power supply is ON
SHUTTER	Green	Lit when shutter is closed
START CHECK	Green	Synchronous with K1 relay (start check)
FLAME	Green	Synchronous with K2 relay (flame detection)

Terminal assignments

Terminal No.	Description	Electrical rating
14	AUD300C/500C Shutter (white)	DC24V 150mA *1
13	AUD300C/500C Shutter (white)	
12	AUD300C/500C G-terminal (yellow)	-
11	AUD300C/500C F-terminal (blue)	
10	Flame voltage output (-)	DC0~5V *2
9	Flame voltage output (+)	
8	Combustion lamp output (K3)	3A 250V (cosφ=1) *3
7	Combustion lamp output (K3)	
6	Flame output (K1, K2)	5A 250V (cosφ=1)
5	Common output contact	-
4	K2 relay (N.C. flame relay)	5A 250V(cosφ=1)
3	Start input	-
2	Power supply (R) high-voltage side	AC100/200V 50/60Hz
1	Power supply (S) ground side	

*1 : Shutter does not have polarity.

*2 : Use a measuring instrument with an input impedance of 100 KΩ min. To connect this device, use IV lead wires of 0.75 mm² no longer than 10 m.

*3 : Operation is the same as for the K2 relay. (However, since a start-checking function is not provided, do not use for combustion control, but only for combustion monitoring.)

AUR350C part names

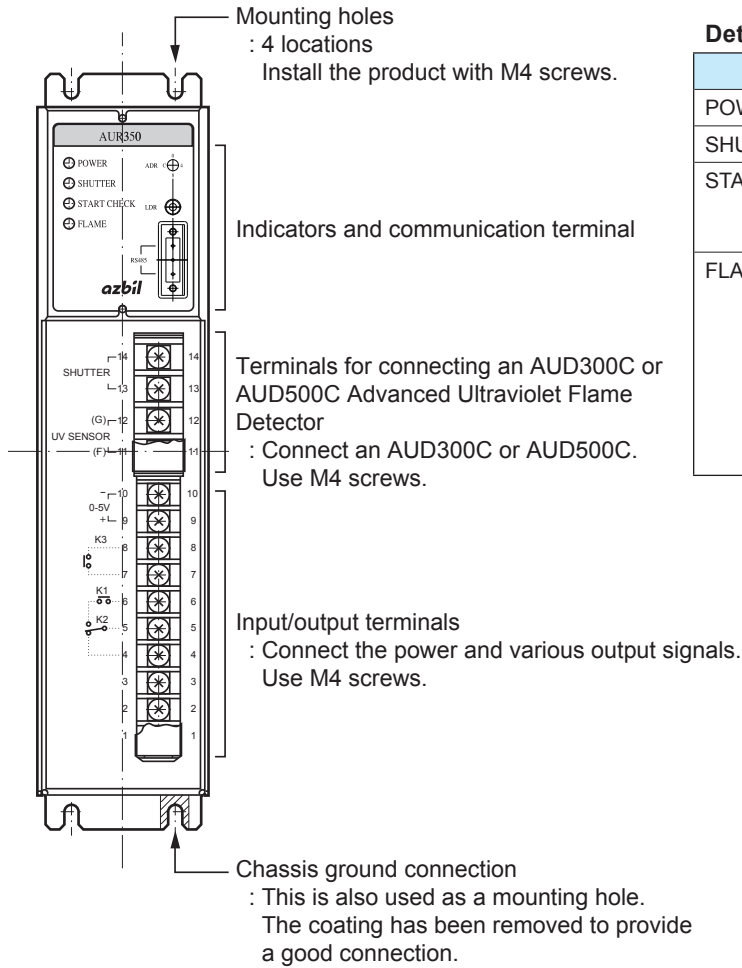

Details on indicators

Name	Color	Description
POWER	Green	Lit when power supply is ON
SHUTTER	Green	Lit when shutter is closed
START CHECK	Green	Synchronous with K1 relay (start check)
	Red	Blinks when an event occurs.
FLAME	Green	Synchronous with K2 relay (flame detection)
	Orange	The color depends on the flame voltage. Green : 2.5 V min. Orange : 1.5 to 2.5 V Red : Less than 1.5 V
	Red	Off when the K2 relay is off.

Terminal assignments

Terminal No.	Description	Electrical rating
14	AUD300C/500C Shutter (white)	DC24V 150mA *1
13	AUD300C/500C Shutter (white)	
12	AUD300C/500C G-terminal (yellow)	-
11	AUD300C/500C F-terminal (blue)	
10	Flame voltage output (-)	DC0~5V *2
9	Flame voltage output (+)	
8	Combustion lamp output (K3) *3	3A 250V(cosφ=1)
7	Combustion lamp output (K3) *3	
6	Flame output (K1, K2)	5A 250V(cosφ=1)
5	Common output contact	-
4	K2 relay (N.C. flame relay)	5A 250V(cosφ=1)
3	Start input	-
2	Power supply (R) high-voltage side	AC100/200V 50/60Hz
1	Power supply (S) ground side	

*1 : Shutter does not have polarity.

*2 : Use a measuring instrument with an input impedance of 100 KΩ min. To connect this device, use IV lead wires of 0.75 mm² no longer than 10 m.

*3 : For the K3 relay, various outputs upon the occurrence of an abnormal state can be specified using the loader. With the default settings, the K3 relay turns on when an event occurs (specifically, when K2 turns off because of false discharge).

● **Switch layout and function**

The AUR350C has a station address setting switch for communications, and also reset switches. These switches are located behind the protective plate of the AUR350C display.

To set a station address or to reset events or values, pull the upper part of the plate toward you to remove it from the peg, and slide the plate upward.

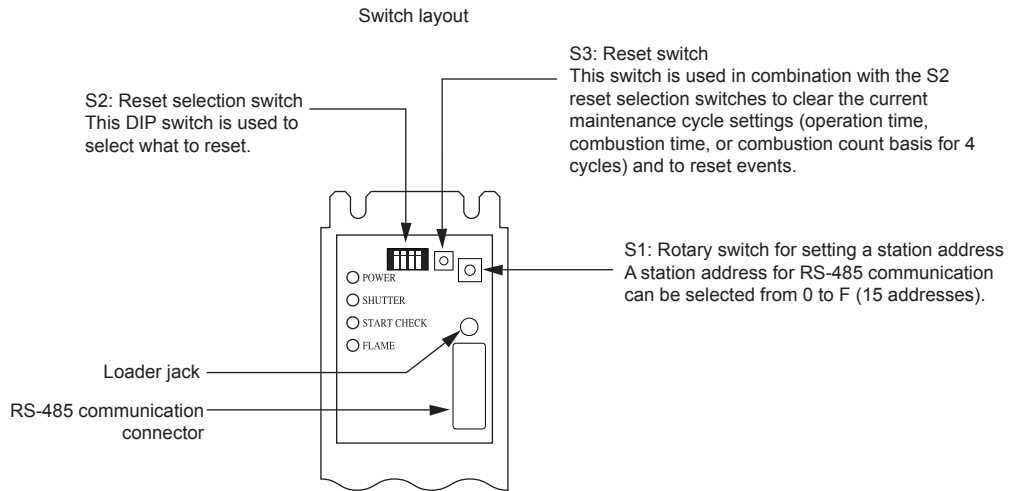

**Events or current values are reset by pressing the S3 switch.
What is reset depends on on/off state of the S2 DIP switches.**

S2				What is reset by pressing the S3 switch
1	2	3	4	
-	-	-	-	Events
○	-	-	-	The current value of the item specified in maintenance cycle setting 1
-	○	-	-	The current value of the item specified in maintenance cycle setting 2
-	-	○	-	The current value of the item specified in maintenance cycle setting 3
-	-	-	○	The current value of the item specified in maintenance cycle setting 4

○ : ON - : OFF

Multiple S2 switches can be ON at the same time. For example, if the S3 reset switch is pressed with S2-1 and S2-3 set to ON, the current value of the items specified for maintenance cycles 1 and 3 will be cleared. All S2 switches are set to OFF at the factory.

Wiring

● Monitoring of burner flame

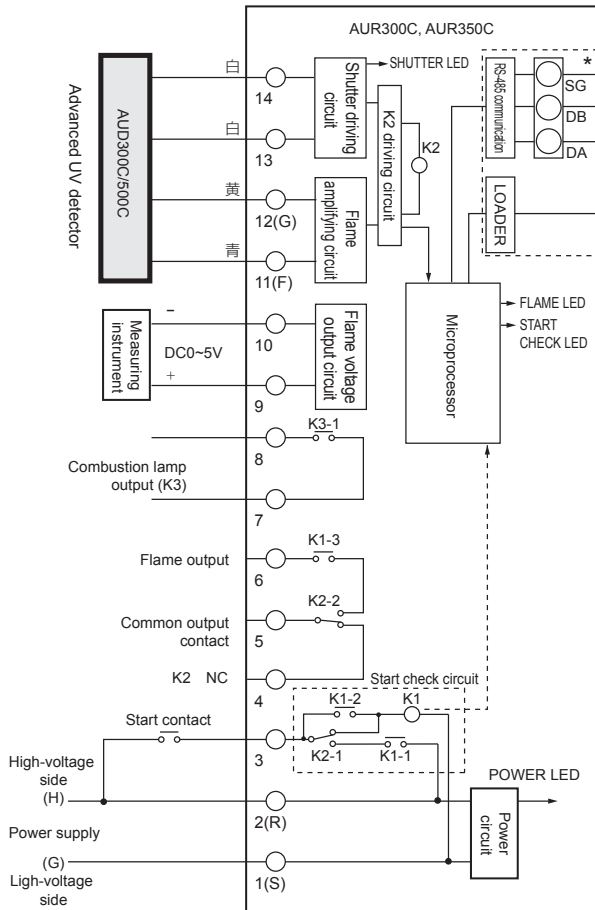

● Manual ignition (intermittent pilot)

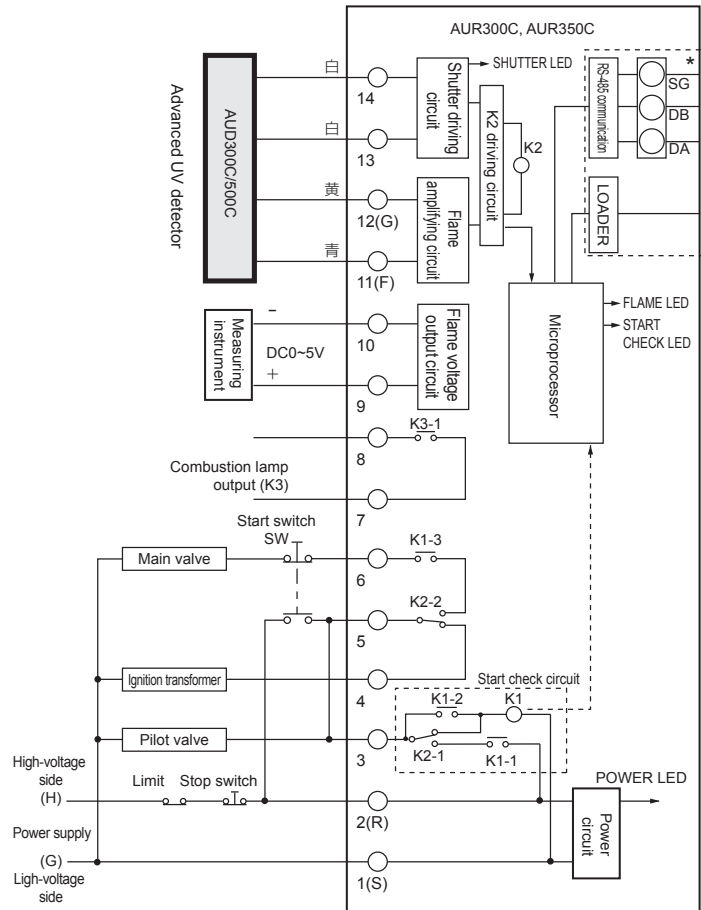

* : Only AUR350C

! Handling Precautions

- If the power supply circuit has a high potential side (H) and low potential side (G), connect the high potential side (H) to terminal 2 (R) and the low potential side (G) to terminal 1 (S).
- If necessary, connect a device for overload protection to the power supply.

Dimensions

(Unit : mm)

• AUR300

• AUR350

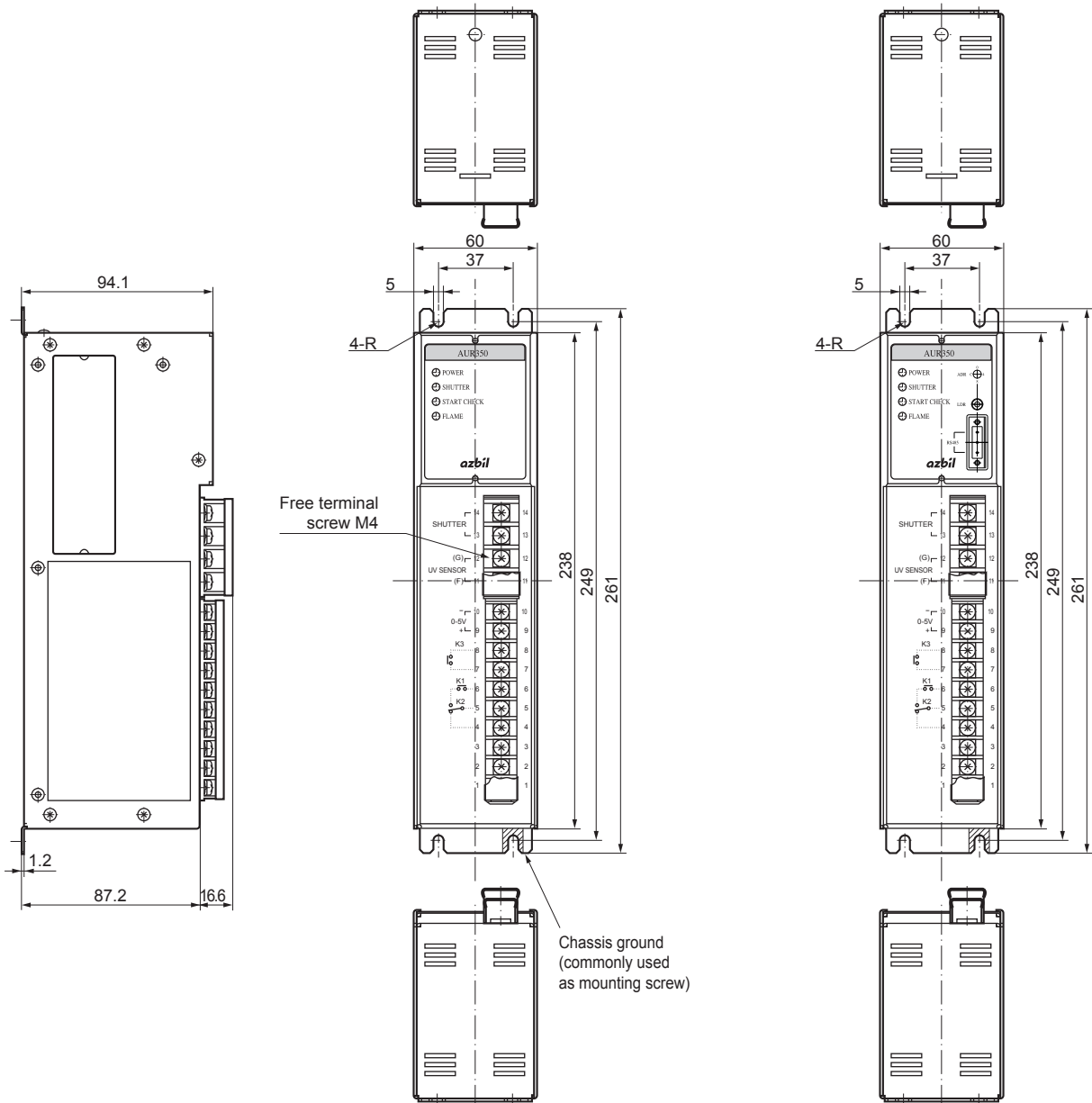

Cautions

- (1) Do not install the flame relay in the following locations:
 - Near the following chemicals or where their vapors are present: ammonia, sulfur, chlorine, ethylene compounds, acid, or any other corrosive gases.
 - Locations subject to water spray
 - Locations subject to continuous vibration
- (2) Before wiring, be sure to turn the power off. Touching terminals by mistake while the power is on may damage the device or result malfunction, or electrical shock.
- (3) After completing wiring, be sure to check all wiring connections. Incorrect wiring may damage the device or result in malfunction. In particular, as the flame detector (11(F)-12(G) terminals) has polarity, a reversed connection of F and G will result in the malfunction of the detector tube unit.
- (4) Use a dedicated packing case when transporting or storing this detector.
- (5) Do not bundle the power leads together with the flame detector signal lead wires, nor place them in the same conduit. Use independent cables.
- (6) Do not short-circuit the start input (terminals 2 and 3) to operate the device by turning the power supply on or off. This interferes with the device's start-checking function.
- (7) This device must be grounded with a resistance less than 100Ω according to the technical standards for electrical facilities. Be sure to ground the device.
- (8) Make sure that the ignition transformer high-voltage cables are properly connected in order to prevent faulty contacts. If there is a poor contact, radio frequency waves may be generated, resulting in errors from radio interference. Install the ignition transformer directly onto a metal part electrically connected to the burner.
- (9) Protection against induced lightning surge is not provided in this device. When adding surge protection, connect the protection device between terminal No.1 and the ground.
Recommended surge absorber: Part No. 83968019-001.
- (10) Turning the power supply on and off quickly may result in malfunction. Wait an interval of approx. 3 s before turning the device on or off again.
- (11) Electricity may remain in No.11 (F) terminal even after the power supply is turned off. Touching the terminal within 1 min after the power has been turned off might result in electric shock. Do not touch the No.11 (F) terminal soon after the power has been turned off.

Please read "Terms and Conditions" from the following URL before ordering and use.

<http://www.azbil.com/products/factory/order.html>

Specifications are subject to change without notice.



Azbil Corporation
Advanced Automation Company

1-12-2 Kawana, Fujisawa
Kanagawa 251-8522 Japan
URL: <http://www.azbil.com/>

1st edition: Jun. 2002
7th edition: Nov. 2017

No part of this publication may be reproduced or duplicated without the prior written permission of Azbil Corporation.