

Separate Type Temperature Humidity Sensor HTY7843 User's Manual



Thank you for purchasing the HTY7843.
This manual contains information for ensuring correct use of the HTY7843.
It also provides necessary information for installation, maintenance, and troubleshooting.
This manual should be read by those who design and maintain devices that use the HTY7843.
Be sure to keep this manual nearby for handy reference.
Please read the "Terms and Conditions" from the following URL before ordering or use:
<http://www.azbil.com/products/bi/order.html>

NOTICE

Be sure that the user receives this manual before the product is used.
Copying or duplicating this user's manual in part or in whole is forbidden. The information and specifications in this manual are subject to change without notice.
Considerable effort has been made to ensure that this manual is free from inaccuracies and omissions. If you should find an error or omission, please contact the azbil Group.
In no event is Azbil Corporation liable to anyone for any indirect, special or consequential damages as a result of using this product.

© 2003-2015 Azbil Corporation All Rights Reserved.

SAFETY PRECAUTIONS

Safety precautions are for ensuring safe and correct use of this product, and for preventing injury to the operator and other people or damage to property. You must observe these safety precautions. Also, be sure to read and understand the contents of this user's manual.



CAUTION

Cautions are indicated when mishandling this product might result in minor injury to the user, or only physical damage to this product.

CAUTION

- To ensure the safety, the connection work must be carried out only by the authorized engineers having special skill about instrumentation and electric construction work.
- Always operate the HTY7843 within the rated input/output specification range defined in this manual. Failure to do so might cause faulty operation.
- Always install the HTY7843 in the operating environment clarified in this manual. Failure to do so might cause faulty operation.
- Compositions of gas to be measured, such as corrosive gas or organic solvent might cause measurement error, short product service life, or faulty operation. When operating the HTY7843 in an environment other than the normal air environment, always consult Azbil Corporation's sales person.
- Before starting the wiring work, always shut-down the power supply completely. Failure to do so might cause faulty operation.
- Carry out the wiring work properly according to the predetermined indoor wiring and electric equipment technical standards.
- Do not disassemble the HTY7843. Doing so might cause faulty operation.
- If the HTY7843 malfunctions, excessively humid state may occur due to output drop. When necessary, take appropriate safety measures on the system or equipment side.
- When disposing of the HTY7843, dispose of it appropriately as industrial waste in accordance with local bylaws and regulations.

UNPACKING

When unpacking the HTY7843, check that the model No. you have received is the product you ordered, that the product does not have any apparent physical damage, and that all accessories are included.
If any damage is found or any package contents are missing, immediately contact your dealer.
The product package includes the following accessories:

- Main body
- Tie-up band
- Sponge
- User's Manual CP-UM-5304

1. OVERVIEW

Overview

This separate type temperature humidity sensor HTY7843 is a highly precise and reliable sensor, in which a Pt100 platinum RTD (JIS C1604 class A) is used for the temperature sensing element and a polymer capacitive film humidity sensing element (Azbil Corporation's development model No. FP3TM) is used for the humidity detection element.
This separate type temperature humidity sensor provides a wide measuring range and excellent stability.
Therefore, this sensor can be used for measurement of the outside air and in various industrial fields, such as insides of air-conditioner ducts and chambers.

■ Features

- The temperature and humidity can be measured precisely in a wide range.
- The environment-proof is excellent.
- The long-term stability is excellent.
- The responsibility and reproducibility are excellent.
- The probe is separated from the amplifier to achieve a compact design. This allows measurement in a narrow space and mounting on a small device.
- As an optional filter is attached to the probe, the protection structure of the probe is improved to the IP54 dust-proof and splash-proof structure.
- This sensor is applicable to the CE marking.
Directives : 2004/108/EC (Electromagnetic Compatibility (EMC) directive)
EN50081-1/1992(EN55011/1998 group1, class B)
EN61326-1 Class B Table 1 (For use in a basic electromagnetic environment)

2. MODEL SELECTION GUIDE

Select a model No. from Table below:

Model No.	Outputs	
	Humidity	Temperature
HTY7843D1P00	1 to 5 V *1	Pt 100 *4
HTY7843D1100	1 to 5 V *1	1 to 5 V *5
HTY7843D6600	0 to 10 V *2	0 to 10 V *6
HTY7843D1A00	1 to 5 V *1	1 to 5 V / 15 to 35°C *7
HTY7843D4400	4 to 20 mA *3	4 to 20 mA *8

- *1 Humidity voltage output 1 to 5V / 0 to 100%RH.
- *2 Humidity voltage output 0 to 10V / 0 to 100%RH.
- *3 Humidity current output 4 to 20mA / 0 to 100%RH.
- *4 Temperature resistance output Pt100 / 3 wire method.
- *5 Temperature voltage output 1 to 5V / 0 to 50°C.
- *6 Temperature voltage output 0 to 10V / 0 to 50°C.
- *7 Temperature voltage output 1 to 5V / 15 to 35°C.
- *8 Temperature current output 4 to 20mA / 0 to 50°C.

3. MOUNTING

■ Mounting Locations

Mount this sensor in a place shown below where:

- The typical temperature and humidity of gas to be measured can be detected and the specified wind velocity can be kept.
- The entire opening of the probe is put in gas to be measured and the gas flow may be in contact with the probe in the horizontal direction.
- No water drops directly splash onto the probe and no dew condensation occurs.
- Sufficient maintenance and inspection space can be kept.

! Handling Precautions

If this sensor is mounted in a place where a large amount of fine particle dust exists, attach the optional filter to the sensor.

■ Mounting the probe

! CAUTION

- Do not stretch the cable between the probe and amplifier. Doing so might cause cable disconnection or faulty wiring.
- When mounting this sensor on a steam heating air-conditioner, take appropriate measures so that any hot steam does not splash onto it. (If any hot steam splashes onto the sensor, this might cause faulty operation.)

! Handling Precautions

Do not mount the sensor with the opening of the probe faced upward. Doing so might cause water drops to accumulate in the opening.

● When using the mounting bracket (Model No.: FL-PA112):

This bracket is used to mount the probe in parallel to the wall surface.

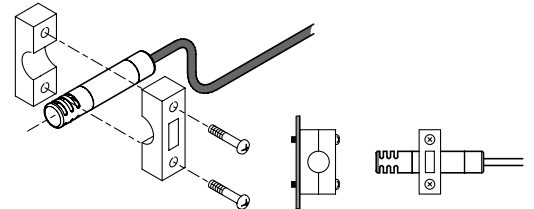

● When using the seal connector:

This connector is used to mount the probe through the wall.

- Filter is not used.

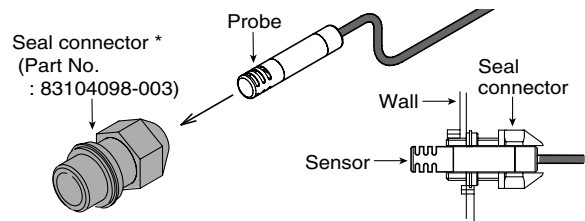

- Filter is used.

Use of this filter makes it possible to improve the protection structure level to the IP54 dust-proof and splash-proof structure.

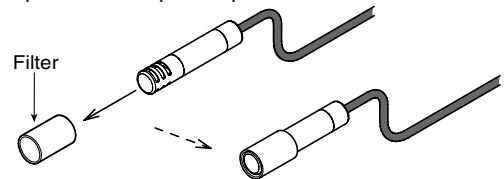

* When mounting the filter, use the seal connector Part No. 83104098-004.

■ Mounting the amplifier

Mount the amplifier on a flat wall surface with four M3 screws. To keep a sufficient maintenance and inspection space, do not mount any device in the shaded portions.

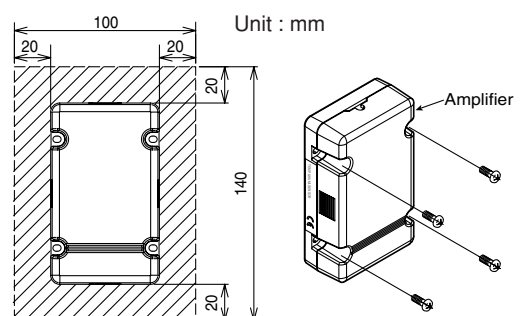

4. WIRING

CAUTION

- Do not stretch any lead wire. Doing so might cause the sensor to malfunction or faulty wiring.

The recommended wiring cable is AWG22 or its equivalent. For the crimp terminal, use the crimp terminal for the M3 screw terminal (JST Mfg. Co. VD1.25-N3A or its equivalent).

When using the voltage output or temperature (3-wire RTD) output, the maximum wiring length is 50m.

After the wiring has been completed, make sure again that the wiring is connected properly before turning ON the power.

Wiring diagram

Humidity output is the voltage output (Model No. : HTY7843D1***)

Humidity output is the current output (Model No. : HTY7843D4 ***)

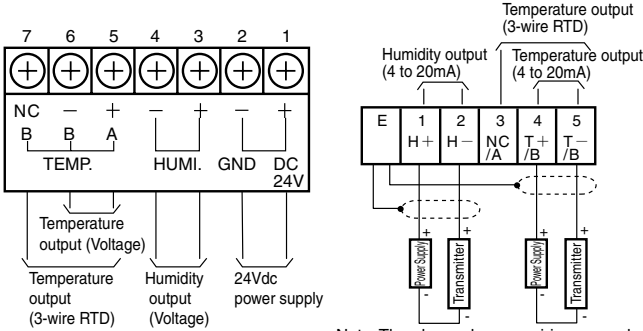

Note: The above shows a wiring example when both the temperature and humidity are the current output.

Handling Precautions

In the voltage output type sensor, the negative line of the voltage output is short-circuited with the negative line of the 24Vdc power supply. Therefore, great care should be taken if other units also use the same power supply commonly.

Wiring method

- Remove the cover of the amplifier. As shown in the Fig. below, remove the cover so that it is raised with its long sides kept pushed.

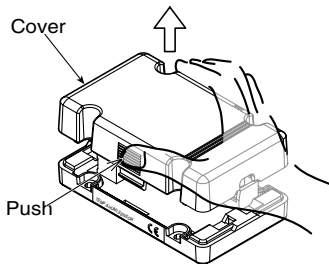

- When the humidity output is the voltage output: Attach crimp terminals to the lead wires and connect them to relevant terminals. (Terminal tightening torque: 0.5 N·m)

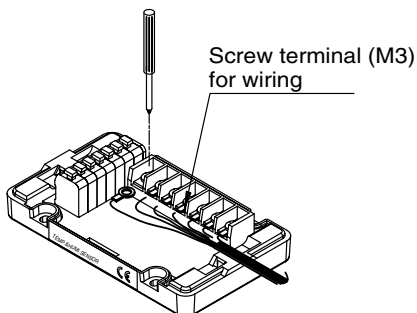

When the humidity output is the current output: Strip the sheath approximately 9 to 10 mm from the top of the lead wire and connect it to relevant single touch terminal so that the wiring label on the lead wire is matched with that on the terminal.

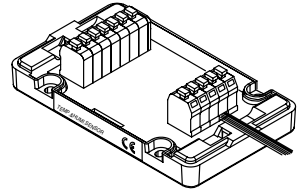

- Secure the cable to the case.

Humidity output is the voltage output.

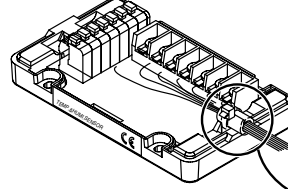

Wind the sponge supplied with the sensor around the cable, and then secure the cable with the tie-up band.

Humidity output is the current output.

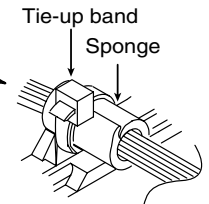
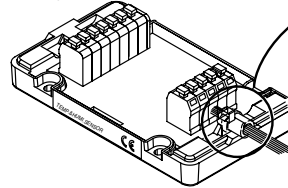

- Mount the cover to its original position.

Handling Precautions

Do not operate the sensor with the cover removed. After the wiring has been completed, always mount the cover firmly again.

5. MAINTENANCE

This sensor has been inspected and adjusted properly before shipment from the factory.

Therefore, it is not necessary to make the adjustment again at the installation site.

Carry out the maintenance of the sensor properly while referring to the following items:

Periodic inspection

- According to the amount of fine particle dust flying in gas to be measured or the contamination status, check the detection accuracy periodically.
- Check the filter for clogging. When necessary, clean the filter. If the filter is contaminated excessively, replace it with a new one.

Troubleshooting

If any trouble is found during operation, inspect the sensor while referring to the Table below and take corrective actions.

Trouble	Inspection	Corrective action
<ul style="list-style-type: none"> Output signal is not output. Output fluctuates. 	<ul style="list-style-type: none"> Check for loose wiring. Check the cable for faulty wiring. Check the power voltage. Check the sensor main body for breakage. 	<ul style="list-style-type: none"> Retighten the terminal. Carry out the wiring again. Replace the sensor.
<ul style="list-style-type: none"> Output response is slow. 	<ul style="list-style-type: none"> Sensor main body gets damp or dew condensation occurs. 	<ul style="list-style-type: none"> Remove the sensor from the mounting place and dry it naturally with the power turned OFF in the clean atmosphere. At this time, if the filter is attached to the sensor, detach it.
<ul style="list-style-type: none"> Sensor has a measuring error. 	<ul style="list-style-type: none"> Check the mounting location. Check the contamination status of the sensor main body. 	<ul style="list-style-type: none"> Mount the sensor in a place meeting the specified conditions (stated on page 2). Clean the filter. Replace the filter. Replace the sensor main body.

6. SPECIFICATIONS

Item		Specifications	
Detection accuracy	Temperature	±0.3 °C (Pt 100 output) ±0.5 °C (1 to 5Vdc output, 0 to 10Vdc output) ±0.5 °C (4 to 20mAdc output)	
	Humidity	±3% RH (30 to 70%RH at 25°C) ±5% RH (20 to 80%RH at 15 to 35°C)	
Output signal	Temperature	JIS Pt 100 (3-wire method) 1 to 5Vdc / 0 to 10Vdc (The temperature range specified by model) : the minimum input impedance is 50kΩ. 4 to 20mAdc (2-wire method) : the maximum load resistance at a power voltage of 24Vdc is 500Ω.	
	Humidity	1 to 5Vdc / 0 to 10Vdc (Linear to 0 to 100%RH) : the minimum input impedance is 50kΩ. 4 to 20mAdc (2-wire method) : the maximum load resistance at a power voltage of 24Vdc is 500Ω.	
Operating environmental conditions	Probe	Rated operating conditions 0 to 50°C 5 to 95%RH (No condensation allowed.) Limit operating conditions -20 to +80°C 0 to 100%RH (No condensation allowed.) Transportation/Storage conditions -20 to +70°C 5 to 95%RH (No condensation allowed.)	
		Amplifier	Rated operating conditions 0 to 50°C 10 to 90%RH (No condensation allowed.) Limit operating conditions 0 to 50°C 5 to 95%RH (No condensation allowed.) Transportation/Storage conditions -20 to +70°C 5 to 95%RH (No condensation allowed.)
			Wind velocity
Time constant (at wind velocity of 2 m/s)	Temperature	3 min. or less.	
	Humidity	30s or less	
Power voltage	24Vdc ± 10%		
Power consumption	0.2W or less (When humidity output is the voltage output.)		
Dielectric strength	Leak current is 1mA or less when 500Vac is applied for 1 min. (Between case and power terminal)		
Insulation resistance	20 MΩ or more when measured using 500Vdc-Megger. (Between case and power terminal)		
Vibration resistance	4.9m/s ² (10 to 65Hz), 9.8m/s ² in the packing status (10 to 150Hz for 2 hrs. in each of X, Y, and Z directions)		
Protection structure	Probe: Dust-proof and splash-proof structure (IP54) (When the filter is attached.)		
Mounting	Amplifier: M3 screw x 4		
Connection	Voltage output type: Terminal base connection (M3 screw) Current output type: One-touch terminal		
Material/Color	Probe	SUS304	
	Amplifier	Modified PE resin(UL94-V0), Gray (DIC-651 or its equivalent)	
Mass	Approximately 150g (The mass of the probe is approximately 60g.)		
Accessories	Tie-up band (1 unit), Sponge (1 unit)		

External dimensions

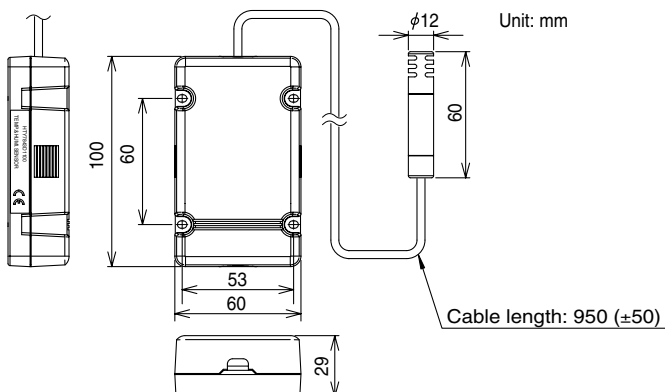

Optional parts (Sold separately)

Name	Part No.
Wall mounting bracket	FL-PA112
Seal connector	83104098-003 (Without filter)
	83104098-004 (With filter)
Filter	83162951-002

azbil

Azbil Corporation
Advanced Automation Company

1-12-2 Kawana, Fujisawa
Kanagawa 251-8522 Japan

URL: <http://www.azbil.com>

Specifications are subject to change without notice. (09)

1st edition: July 2003 (M)
5th edition: Aug. 2015 (M)