

1LS□-J401 SERIES ALL STAINLESS STEEL LIMIT SWITCHES

Continuous use under water or in other harsh environments or corrosive gas atmospheres is possible.



- Superior resistance to salt and corrosive gases
- May be used under water.

APPLICATIONS

- Chemical plants (acid and alkali resistant)
- Harbor facilities (protected against salt water corrosion)
- Dams and floodgates



ORDER GUIDE

Actuator		Cable type	Catalog listing
Name	Shape		
Roller lever		None	1LS1-J401
		30 m	1LS1-J401-03
		50 m	1LS1-J401-05
Adjustable roller lever type		None	1LS3-J401
		30 m	1LS3-J401-03
		50 m	1LS3-J401-05
Without lever	—	None	1LS2-J401
		30 m	1LS2-J401-03
		50 m	1LS2-J401-05

PERFORMANCE

Standards	Compliance	NECA C 4508	
Structure	Contact form	2-circuit double break	
	Terminal type	M4 screw (switch terminal screw)	
	Contact type	Rivet	
	Protective structure	IP67 (IEC 60529, JIS C 0920)	
Electrical performance	Electrical rating	See Table 1.	
	Dielectric strength	Between non-continuous terminals	1,000 Vac, 50/60 Hz for 1 minute
		Between each terminal and non-live metal part	2,000 Vac, 50/60 Hz for 1 minute
	Insulation resistance	Min. 100 M Ω (by 500 Vdc megger)	
	Initial contact resistance	Max. 50 m Ω (6 to 8 Vdc, thermal current 1A, voltage drop method)	
	Recommended min. contact operating voltage/current	24 Vdc 10 mA, 100 Vac 10 mA	
Mechanical performance	Actuator strength	Withstands load 5 times O.F. (operating direction for 1 minute)	
	Terminal strength	Withstands tightening force of 1.5 N·m for 1 minute	
	Impact resistance	Contacts open for 1 ms max. at 300 m/s ² in free position and total travel position	
		1.5 mm peak-to-peak amplitude, frequency 10 to 55 Hz, for 2 continuous hours Contacts open for 1 ms max. in free position and total travel position.	
	Vibration resistance	1.7 mm/s to 0.5 m/s	
	Allowable operating speed	Max. 120 operations/minute	
Life	Mechanical	Min.2 million operations (with O.T. at 1/3 to 2/3 the rated value)	
	Electrical	Min. 100,000 operations (tested at rated load and operating freq. of 20 times/minute)	
Ambient operating conditions	Temperature	-5 to +70°C(freezing not allowed)	
	Humidity	Max. 98% RH	
Recommended tightening torque	Body	5 to 6 N·m (M5 hexagon socket head bolt)	
	Cover	1.3 to 1.7 N·m (M4 screw)	
	Head	0.8 to 1.2 N·m (M3.5 screw)	
	Lever	4 to 5.2 N·m (M5 hexagon socket head bolt)	
	Terminal screw	1.3 to 1.4 N·m (M4 binding head machine screw)	

● Circuit diagram

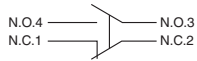

● **Basic dimensions**

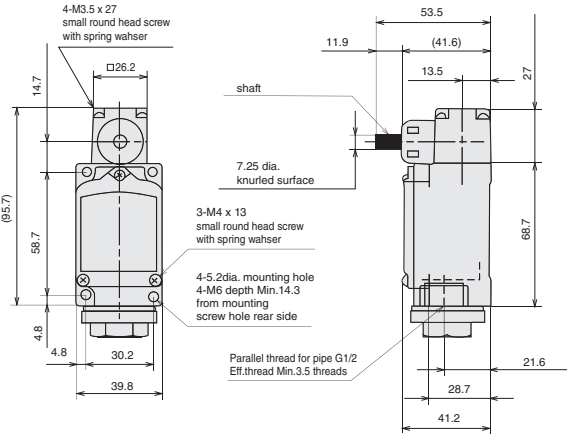

*Dimensional tolerance is ± 0.4 unless otherwise specified.

● **Actuator mounting dimensions**

Roller lever type

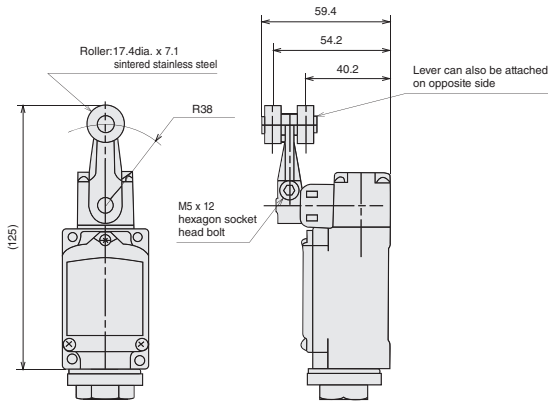

Adjustable roller lever type

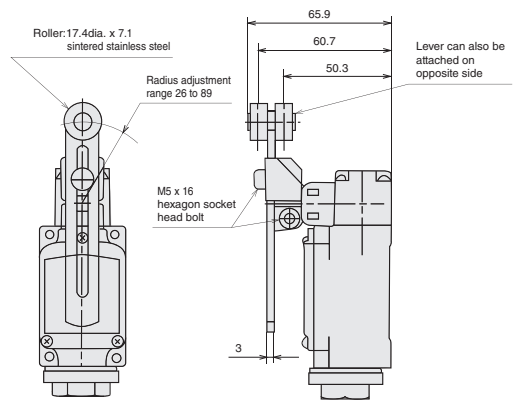

*Dimensional tolerance is ± 0.4 unless otherwise specified.

OPERATING CHARACTERISTICS

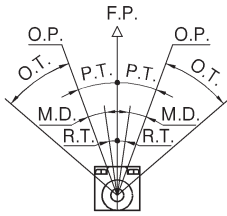

Characteristics	O.F. (Max. N)	13.4
	R.F. (Min. N)	2.2
	P.T. (Max. °)	20
	M.D. (Max. °)	12
	O.T. (Min. °)	30
	R.T. (Min. °)	5

PRECAUTIONS FOR USE

1. Attaching switches

- Tighten each of the parts on the limit switch according to the appropriate tightening torques listed in the performance tables. Overtightening damages screws and other parts. On the other hand, insufficient tightening of screws lowers the effectiveness of the seal and reduces various performance characteristics.
- Do not leave or use covers and conduit parts open. Water, dirt, or dust may enter, which causing malfunction.
- Prevent impact to the lever body and head. Failure to do so might deform the actuator or cause defective switch return.
- Do not use silicone rubber electrical lead insulation, silicone adhesive or grease containing silicone. Doing so might result in defective electrical conductivity.

2. Wiring

- Do not perform wiring with the power ON. Doing so might cause electric shock, or the machine may start unexpectedly, causing an accident.
- Use crimp-type terminal lugs with covered insulation for electrical leads to prevent contact with covers and housings. If a crimp-type terminal lug contacts a cover, the cover may no longer shut or a ground fault may occur.
- Use sealed connectors (**PA1 Series**, etc. sold separately) or flexible tubing (**PA3 Series**) with IP67 or equivalent seal for conduits.
- Firmly tighten covers and conduits. If covers and conduits are not sufficiently tightened, the seal will be impaired and switch performance will no longer be assured.

3. Adjusting switches

- Do not apply excessive force (5 times O.F.) to the actuator beyond the total travel position. Doing so might damage the switch.
- Keep overtravel between 1/3 to 2/3 of the rated value. Small overtravel might cause the contacts to rattle due to vibration and impact, or may result in defective contact.

4. Environment

- Do not use the switch in an environment where strong acid or alkali is directly splashed onto it.

Before use, thoroughly read the "Precautions for use" and "Precautions for handling" in the Technical Guide on pages **D-111** to **D-122** as well as the instruction manual and product specification for this switch.