



Series MFS Magnetic Inductive Flow Sensor

Specifications - Installation and Operating Instructions

Series MFS

Magnetic Inductive Flow Sensor



Table of contents	page
0 About this operating manual.....	3
1 Device description.....	4
1.1 Delivery, unpacking and accessories.....	4
1.2 Intended use.....	5
1.3 Exclusion of liability.....	5
2 Safety instructions.....	6
3 Construction and function.....	7
4 Installation of MFS.....	8
4.1 Installation instructions.....	8
4.2 Mounting.....	9
5 Electrical connection.....	10
5.1 Wirings.....	11
6 Commissioning and measuring mode.....	12
6.1 Commissioning.....	12
6.2 Switching on and off.....	12
6.3 Measuring mode.....	12
7 Maintenance and cleaning.....	14
7.1 Return shipment to the manufacturer.....	14
8 Disassembly and disposal.....	15
9 Technical data.....	16
9.1 Characteristics MFS.....	16
9.2 Materials table.....	17
9.3 Pressure drop.....	17
9.4 Temperature limits.....	18
9.5 Dimensions.....	19

Copyright notice:

The reproduction, distribution and utilization of this operating manual as well as the communication of its contents to others without express authorization is prohibited. Offenders will be held liable for the payment of damages. All rights reserved in the event of the grant of a patent, utility model or design.

0 About this operating manual

- The operating manual is aimed at specialists and semi-skilled personnel.
- Before each step, read through the relevant advice carefully and keep to the specified order.
- Thoroughly read and understand the information in the section "Safety instructions".

If you have any problems or questions, please contact your supplier or contact us directly at:



Dwyer INSTRUMENTS, INC.
P.O. Box 373 • Michigan City
INDIANA 46361, U.S.A.
Phone: (219) 879 - 8000
Fax: (219) 872 - 9057
Email: info@dwyer-inst.com

Hazard signs and other symbols used:



WARNING! / CAUTION! Risk of injury!

This sign indicates dangers that cause personal injuries that can lead to health defects or cause considerable damage to property.



CAUTION! Electric current!

This sign indicates dangers which could arise from handling of electric current.



CAUTION! Material damage!

This sign indicates actions which could lead to possible damage to material or environmental damage.



ADHERE TO OPERATING MANUAL!



NOTICE!

This symbol indicates important notices, tips or information.



NO DOMESTIC WASTE!

The device must not be disposed of together with domestic waste.



Pay attention to and comply with information that is marked with this symbol.



Follow the specified instructions and steps. Adhere to the given order.



Check the specified points or notices.



Reference to another section, document or source.



Item.

1 Device description

The sensor of the MFS series from Dwyer, is a non-contact flow sensor. The measurement is performed using magnetic induction and works without any moving parts.

The MFS is used for measuring or metering water and aqueous solutions. The compact design and independence from the intake and discharge sections allows the MFS to be used under a variety of conditions.

Versions *:

The MFS is available with inner diameters 0.39 in narrows to 0.16 in, 0.39 in and 0.79 in.

The versions can be configured differently (→ MFS data sheet).

Type plate:

The type plate sticker is located at the bottom side of the MFS.

It contains the most important data, the connection diagram and the arrow for the flow direction (Example → Fig.).

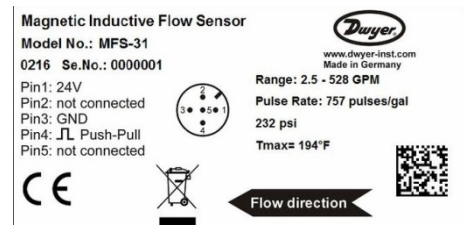

1.1 Delivery, unpacking and accessories

All units have been carefully checked for their operational reliability before shipment.

- Immediately after receipt, please check the outer packaging for damages or any signs of improper handling.
- Report any possible damages to the forwarder and your responsible sales representative. In such a case, state a description of the defect, the type and the serial number of the device.
Report any in-transit damage immediately. Damage reported at a later date shall not be recognized.

Unpacking:

- ☞ Carefully unpack the unit to prevent any damage.
- ☞ Check the completeness of the delivery based on the delivery note.

Scope of delivery:

- 1x MFS as ordered.
- 1x Operating manual.
- 1x Packing.



* Customised versions available on request.

**IMPORTANT!**

- ↳ Use the type plate to check if the delivered unit corresponds to your order.
- ↳ In particular, for devices with electrical components, check to see if the correct power supply voltage is specified.

Accessories:

- Connection cable with molded M12x1 coupling socket.
- M12x1 coupling socket as component.

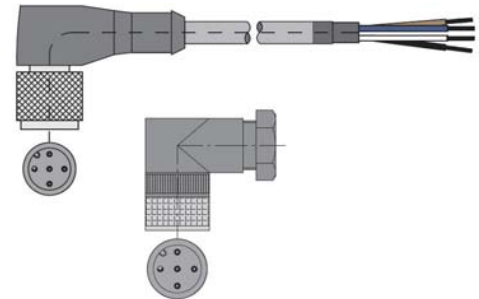

1.2 Intended use

The magnetic inductive flow sensor MFS must only be used for measuring and metering liquids with a minimum conductivity of 50 $\mu\text{S}/\text{cm}$.

**WARNING! No safety component!**

The magnetic inductive flow sensor of the series MFS is not safety components in accordance with Directive 2006-42-EC (Machine Directive).

- ↳ Never use the MFS as a safety component.

The operational safety of the device supplied is only guaranteed by intended use. The specified limits (\rightarrow § 9 "Technical data") may under no circumstances be exceeded.

Before installing the device, check that the wetted materials of the device are compatible with the media being used (\rightarrow § 9.2 "Materials table").

Measuring tube empty (or partially filled). / Conductivity too low.



The green LED may blink irregularly if the measuring tube of the MFS is empty or partially filled or if the conductivity of the fluid being used is too low. Random impulses will be present at the output, but they do not represent an actual flow.

- ↳ Ensure that the measuring tube of the MFS is always completely filled (\rightarrow § 4.1 "Installation instructions").
- ↳ Ensure that the conductivity of the fluid is at least 50 $\mu\text{S}/\text{cm}$.

1.3 Exclusion of liability

We accept no liability for any damage or malfunctions resulting from incorrect installation, inappropriate use of the device or failure to follow the instructions in this operating manual.

2 Safety instructions



Before you install the MFS, read through this operating manual carefully. If the instructions contained within it are not followed, in particular the safety guidelines, this could result in danger for people, the environment, and the device and the system it is connected to.

The MFS correspond to the state-of-the-art technology. This concerns the accuracy, the operating mode and the safe operation of the device.

In order to guarantee that the device operates safely, the operator must act competently and be conscious of safety issues.

Dwyer provides support for the use of its products either personally or via relevant literature. The customer verifies that our product is fit for purpose based on our technical information. The customer performs customer- and application-specific tests to ensure that the product is suitable for the intended use. With this verification all hazards and risks are transferred to our customers; our warranty is not valid.

Qualified personnel:

- ⚠ The personnel who are charged for the installation, operation and maintenance of the MFS must hold a relevant qualification. This can be based on training or relevant tuition. The personnel must be aware of this operating manual and have access to it at all times.
- ⚠ The electrical connection should only be carried out by a fully qualified electrician.

General safety instructions:

- ⚠ In all work, the existing national regulations for accident prevention and safety in the workplace must be complied with. Any internal regulations of the operator must also be complied with, even if these are not mentioned in this manual.
- ⚠ Degree of protection according to EN 60529:
Please ensure that the ambient conditions at the site of use does not exceed the requirements for the stated protection rating (→ § 9 "Technical data").
- ⚠ Prevent freezing of the medium in the device with appropriate measures.
- ⚠ Only use the MFS if it is in perfect condition. Damaged or faulty devices must be checked without delay and, if necessary, replaced.
- ⚠ When fitting, connecting and removing the MFS use only suitable appropriate tools.
- ⚠ Do not remove or obliterate type plates or other markings on the device, as otherwise the warranty is rendered null and void.

Special safety instructions:

Warnings that are specifically relevant to individual operating procedures or activities can be found at the beginning of the relevant sections of this operating manual.

3 Construction and function

Components:

- ① Housing:
The housing consists of aluminum die casting and has the IP65 degree of protection.
- ② Electrical connection:
The electrical connection is made via 4(5)-pin plug M12x1.
- ③ Operation / flow indicator LED.
- ④ Process connection:
The process connections are available in different sizes.
- ⑤ Type plate (sticker).

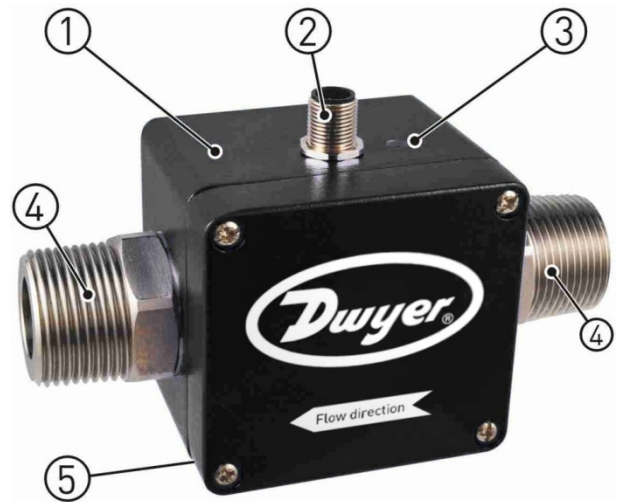

Construction:

The measuring tube with its earthing sleeves and electrodes passes through the housing and forms the external process connection of the MFS.

A magnetic field for the measurement process is generated inside the sensor housing, which also contains the sensor and signal conditioning circuitry.

The two stainless steel electrodes are located in the middle of the measuring tube between the earthing sleeves.

The MFS does not need any moving parts to make measurements. The inside of the measuring tube is completely open, allowing the fluid to flow unhindered through the measuring tube.

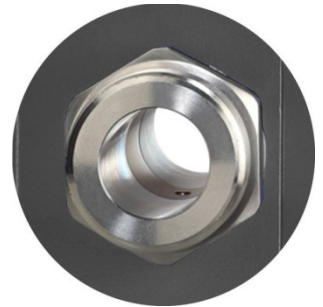

Function:

The magnetic inductive flow sensor operates in accordance with the principle of induction, i.e. a DC voltage is generated by the movement of a conductor in a magnetic field:

The measuring tube of the MFS is located in a magnetic field (B).

An electrically conductive liquid (Q) flows through the measuring tube. The positive and negative charge carriers are deflected in opposite directions.

A voltage perpendicular to the magnet field is generated and picked up by the two electrodes.

The resulting induced voltage is proportional to the mean flow velocity of the liquid.

The electronics of the MFS converts the induced voltage to a flow-proportional frequency signal.

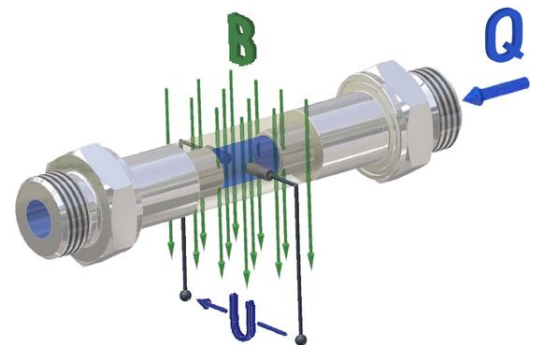

4 Installation of MFS

Before installing, check that

- the wetted materials of the device are suitable for the liquid being used (→ § 9.2 "Materials table").
- the equipment is switched off and is in a safe and de-energized state.
- the equipment is depressurized and has cooled down.



SUITABLE TOOLS:

- ☞ Use only suitable tools of the correct size.

4.1 Installation instructions



CAUTION! Risk of malfunction due to external magnetic fields!

Magnetic fields close to the device can cause malfunctions and should be avoided.

- ☞ Ensure that no external magnetic fields are present at the installation site of the MFS.

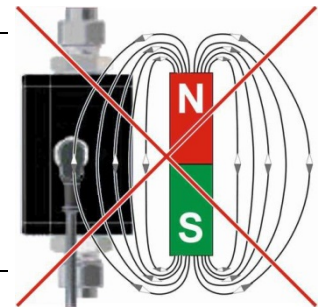

- The MFS can always be installed anywhere along the pipeline. Straight sections of piping are preferable, however.

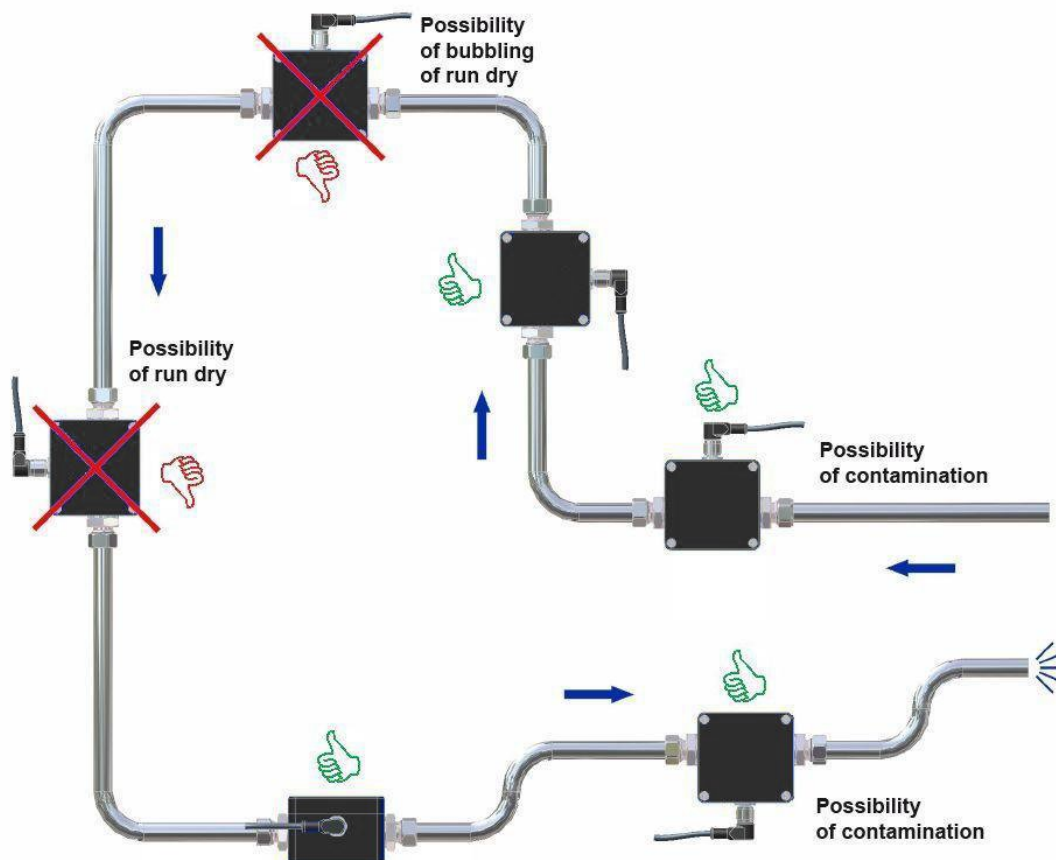

- Installation can occur in horizontal and vertical pipes. The flow sensor is only suitable for application in completely filled pipe systems.
- As a matter of principle magnetic inductive flow sensors are widely independent from the flow profile. An inlet section is not absolutely necessary.
To reach a most highly accuracy of the measurement, you should use straight inlet and outlet sections according to the inner diameter. The inlet section has to be at least 10 x inner diameter; the outlet section 5 x inner diameter in order to achieve the specified accuracy.
- The inlet and outlet sections and gaskets must have the same or a slightly larger inside diameter than the measuring tube in order to achieve the specified accuracy.

4.2 Mounting

The MFS is installed directly into the pipeline. The compact design and light weight of the unit make wall-mounting unnecessary.



IMPORTANT NOTICES:

- Observe the flow direction indicated on the MFS.
 - Observe the mounting dimensions (→ § 9.5 "Dimensions").
- ↪ Select an appropriate location for installation (→ § 4.1 "Installation instructions").
To ensure the best possible measuring accuracy, a vertical installation position with increasing flow is preferable (no collecting of dirt deposits).
- ↪ Wrap the MFS connections with 1 to 2 wraps of thread tape (e.g. Teflon® tape).
Wrap tape in a clockwise direction, viewed from the end, leaving the first two threads uncovered.
- ↪ Make sure the tape does not intrude into the flow path.
- ↪ Attach the MFS with arrow pointed in the direction of flow.
- ↪ The fittings should be screwed into MFS hand tight.



CAUTION! Material damage!

Pay attention to maximum torque.

While tightening, counter the union nut on the hexagon of the process connection!

If you do not counter it, the MFS can be damaged!

Maximum Torque		
MFS-1X • ½"	MFS-2X • ½" • ¾"	MFS-3X • 1"
15 Nm	15 Nm	30 Nm

- ↪ Use two wrenches to tighten the MFS an additional ¾ to 1 turn.
When tightening, use a wrench (AF 1.063 or AF 1.338) to counter the process connection on the hexagon (flange) in place.

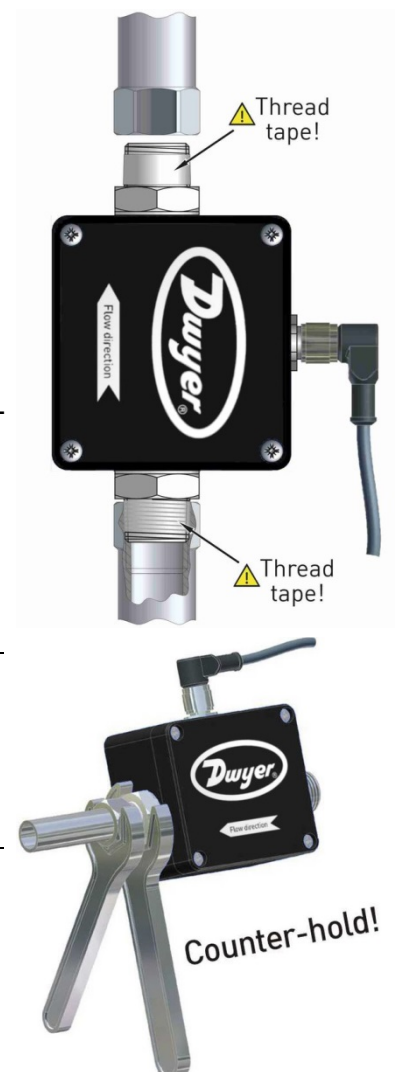

5 Electrical connection

The electrical connection of the MFS is via the 5-pin plug M12x1 at the top of the housing. The wiring of the MFS depends on the ordered version. A distinction is made between frequency and analog output, as well as basic and optional wiring.



CAUTION! Electric current!

The electrical connection should only be carried out by a fully qualified electrician.

↪ De-energize the electrical system before connecting the MFS.



CAUTION! Material damage and fire hazard!

Exceeding the specified limits will cause damage to the electronics. Without current limiting, there is a fire hazard due to overheating of the device.

↪ Connect the MFS only to a power source with limited power.

Optional wirings:

Depending on the version, an analog output can be optionally connected.

Connecting cable:

Suitable connection cables with molded coupling socket are available in various lengths included in the range of Dwyer accessories. The shielding is already connected with the knurled nut.



IMPORTANT! Shielding required!

↪ Use only shielded connection cables.

↪ The shield of the connection cable should not be connected to earth.

We recommend to ground the pipes directly before and behind the MFS (→ Figure).

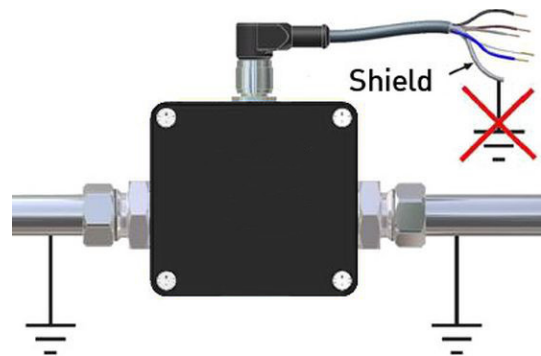

IMPORTANT NOTICE:

Pay attention to the temperature resistance of the connecting cable (→ § 9 "Technical data") at high media temperatures.

If the temperature resistance is smaller than the medium temperature, the cable may not be directly laid on the pipe.

Connection 5-pin plug M12x1:

↪ Screw the coupling socket of the connection cable to the plug of the MFS.

↪ Tighten the knurled nut of the coupling socket with a maximum torque of 1 Nm.

5.1 Wirings

Pinout:

The pinout differs according to the chosen configuration of the device.

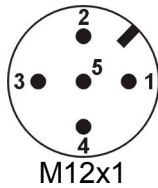

Possible pinout:

Pin 1: **+U_B**

Pin 2: n. c. (not connected) / Analog U/I

Pin 3: **GND**

Pin 4: Frequency

Pin 5: n. c. (not connected) / d. n. c. (do not connect)

↪ Connect the connecting cable according to your version and the pinout on the type plate.

Supply voltage:

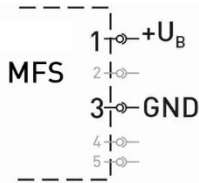

MFS with frequency output:

Push-Pull *1:

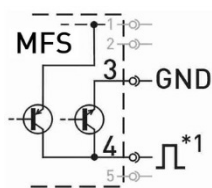

NPN Open Collector:

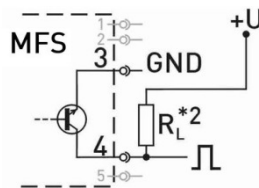

PNP Open Collector:

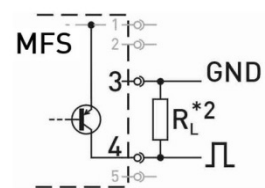

*1: Push-Pull switching outputs of several MFS may not be connected in parallel.

*2: Recommendation Pull-Up / Pull-Down resistance $R_L \sim 5 \text{ k}\Omega$

Use of frequency and analog output:

Push-Pull:

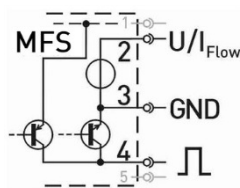

NPN Open Collector:

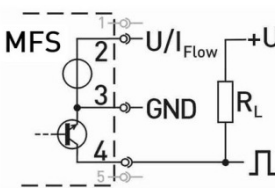

PNP Open Collector:

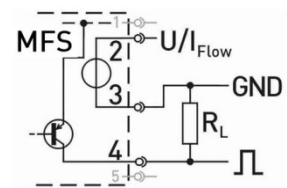

Recommendation for resistance $R_L \sim 5 \text{ k}\Omega$

6 Commissioning and measuring mode

Before switching on the MFS for the first time, please follow the instructions in the following section.

6.1 Commissioning

Check that

- the MFS has been installed correctly and that all screw connections are sealed.
- the electrical wiring has been connected properly.
- the measuring system is vented by flushing.

6.2 Switching on and off

The MFS has no switch and can therefore not be switched on and off independently. Switching on and off takes place via the connected supply voltage.

☞ Switch on the supply voltage.

The green LED lights up once for ~1 s. The MFS is ready and goes into measuring operation.



6.3 Measuring mode

In measuring mode, the green LED flashes corresponding to the frequency of the output signal.



The human eye cannot detect the flashing any longer from a frequency of ~30 ... 40 Hz. In that case the green LED seems to be lit permanently.



The following subsections only apply to devices which have the correspondent functionality.

MFS with frequency output:

The MFS provides according to the version a flow proportional NPN, PNP or Push-Pull square wave signal.

The frequency of the pulse output changes according to the flow (→ Fig.).

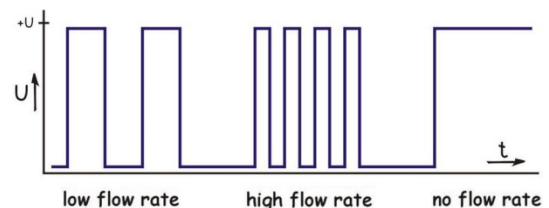

MFS with analog output:

According to the configuration of the MFS, the analog output provides a voltage or current signal.

This signal is proportional to the measured flow.

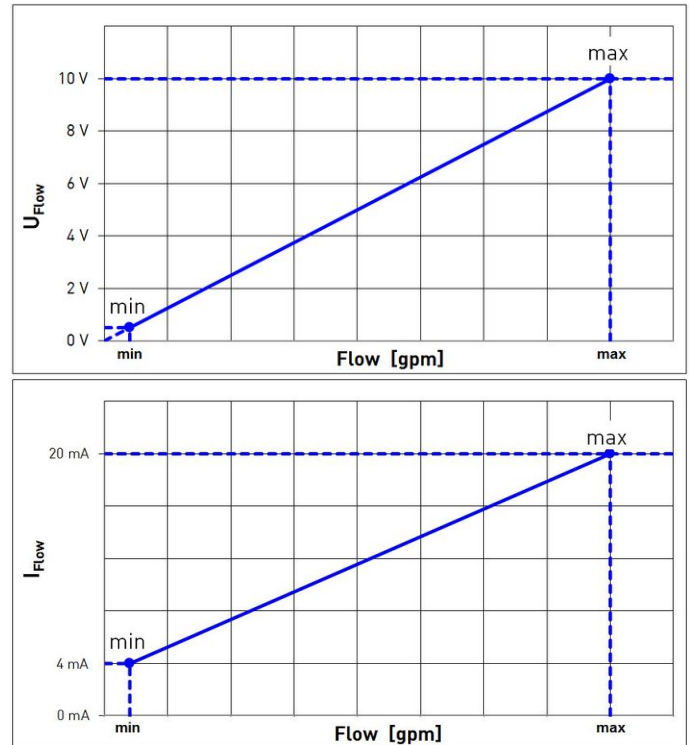

7 Maintenance and cleaning

Maintenance:

The MFS is maintenance-free and cannot be repaired by the user. In case of a defect, the device must be replaced or sent back the manufacturer for repair.



CAUTION! Material damage!

When opening the device, critical parts or components can be damaged.

⚠ Never open the device and perform any repair yourself.

Cleaning:

Clean the MFS with a dry or slightly damp lint-free cloth. Do not use sharp objects or aggressive agents for cleaning.

7.1 Return shipment to the manufacturer

Due to legal requirements placed on environmental protection and occupational safety and health and to maintain the health and safety of our employees, all units returned to Dwyer for repair must be free of toxins and hazardous substances. That also applies to cavities in the devices. If necessary, the customer must neutralize or purge the unit before return to Dwyer.

Costs incurred due to inadequate cleaning of the device and possible costs for disposal and/or personal injuries will be billed to the operating company.



WARNING! Risk of injury due to insufficient cleaning!

The operating company is responsible for all damages and harm of any kind, in particular physical injuries (e.g. caustic burns or toxic contaminations), decontamination measures, disposal etc. that can be attributed to insufficient cleaning of the measuring instrument.

⚠ Comply with the instructions below before returning the unit.

The following measures must be taken before you send the unit to Dwyer for repair:

- ⚠ Clean the device thoroughly. This is of extreme importance if the medium is hazardous to health, i.e. caustic, toxic, carcinogenic or radioactive etc.
- ⚠ Remove all residues of the media and pay special attention to sealing grooves and slits.
- ⚠ Attach a note describing the malfunction, state the application field and the chemical/physical properties of the media.
- ⚠ Please specify a point of contact in case our service department has any questions.

8 Disassembly and disposal



CAUTION! Risk of injury!

Never remove the device from a plant in operation.

↪ Make sure that the plant is shut down professionally.

Before disassembly:

Prior to disassembly, ensure that

- the equipment is switched off and is in a safe and de-energized state.
- the equipment is depressurized and has cooled down.

Disassembly:

- ↪ Remove the electrical connectors.
- ↪ Remove the MFS using suitable tools.

Disposal:



NO HOUSEHOLD WASTE!

The MFS consists of various different materials. He must not be disposed of with household waste.

- ↪ Take the MFS to your local recycling plant
- or
- ↪ send the MFS back to your supplier or to Dwyer.

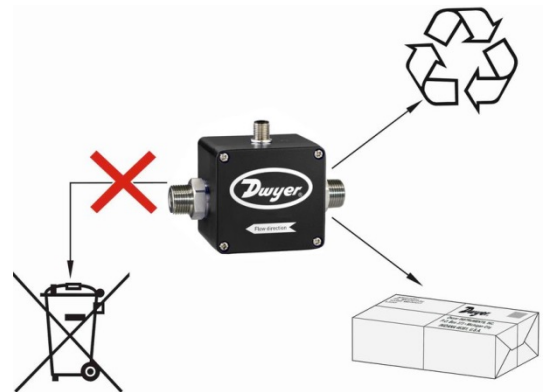

9 Technical data

The technical data of customized versions may differ from the data in these instructions. Please observe the information specified on the type plate.

9.1 Characteristics MFS

Type	MFS-1X	MFS-2X	MFS-3X
Measurement device characteristics			
Measuring range	0.13...8 GPM	0.26...16 GPM	1.3...66 GPM
Accuracy *1 (Frequency output)	±1.5% of reading ±0.3% of full scale value		
Repeatability *1	1%		
Output signal starting from	~0.11 GPM	~0.24 GPM	~1.06 GPM
Response time (frequency / frequency + analog)	< 500 ms / < 800 ms		
Flow indication	LED green, flow proportional flashing		
Output signal characteristics			
Frequency output:			
Pulse rate [pulses/gal] - optional*2	2,000 4...7,500	1,000 4...3,700	250 4...750
Resolution [gal/pulse] - optional*2	0.0005 0.25...0.0001	0.001 0.25...0.0003	0.005 0.25...0.0013
Signal shape	Square wave signal • duty cycle 50:50 Push-Pull • NPN open collector (o.c.) • PNP o.c.		
Signal current	≤ 100 mA, current limited		
Analog output 4...20 mA (optional):			
Signal current corresponding flow of *3	0...5 GPM • 0...8 GPM	0...10 GPM • 0...16 GPM	0...50 GPM • 0...66 GPM
maximum load	250 Ω to GND		
Analog output 0...10 V (optional):			
Signal voltage corresponding flow of *3	0...5 GPM • 0...8 GPM	0...10 GPM • 0...16 GPM	0...50 GPM • 0...66 GPM
Electrical characteristics			
Supply voltage	24 V _{DC} ±10%		
Current consumption	≤ 150 mA		
Electrical connection	5-pin plug M12x1		
Degree of protection (EN 60529)	IP 65 (with attached coupling socket)		

*1 Test conditions: Water 73.4 °F at 150 ±100 µS/cm; Standard pulse rate.

*2 factory setting.

*3 other ranges on request.

Type	MFS-1X	MFS-2X	MFS-3X
Process variables			
Medium to measure:	Water and others conductive liquids		
- Conductivity	> 50 $\mu\text{S/cm}$		
- Temperature	41...194 °F		
Ambient temperature	41... T_{max} °F (\rightarrow § 9.4)*		
Inner diameter	0.39 in narrows to 0.16 in	0.39 in	0.79 in
Nominal pressure	232 psi		
Process connection	½" NPT male thread	½" NPT male thread • ¾" NPT male thread	1" NPT male thread

* The maximum ambient temperature depends on the temperature of the medium and the wiring of the MFS.

9.2 Materials table

Component	Material	Wetted component
Housing	Aluminum die casting	
Measuring tube	PEEK-GF30	X
Electrodes	Stainless steel 1.4571	X
Gaskets	EPDM • FKM (optional)	X
Process connections	Stainless steel 1.4571	X

9.3 Pressure drop

MFS-1X and MFS-2X:

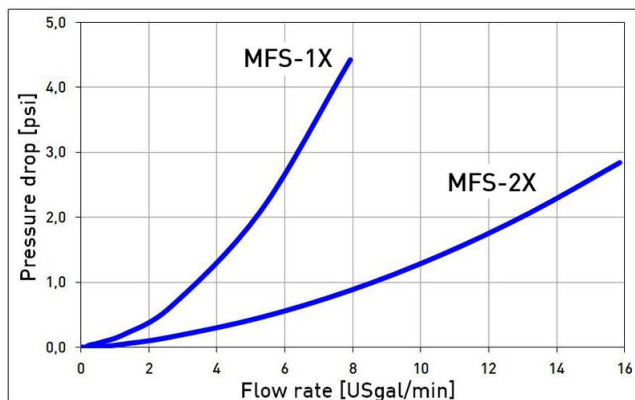

MFS-3X:

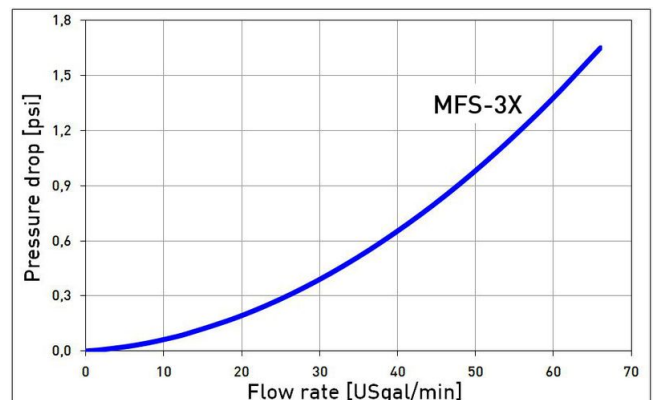

9.4 Temperature limits

The maximum ambient temperature depends on the medium temperature and the version of the MFS.

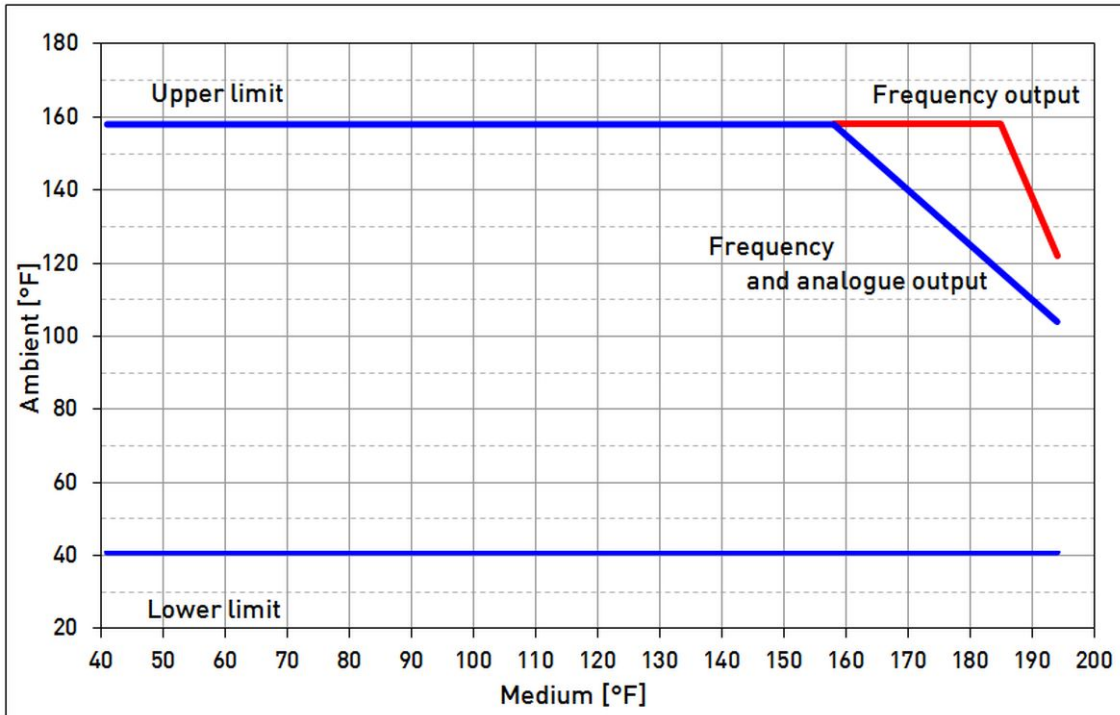

9.5 Dimensions

MFS-1X and MFS-2X:

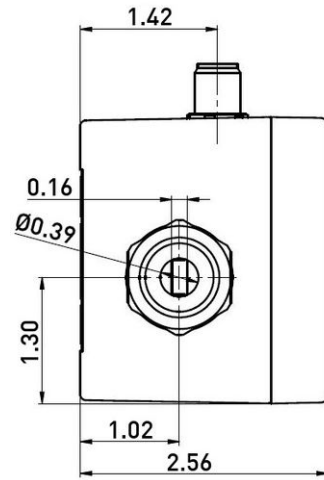
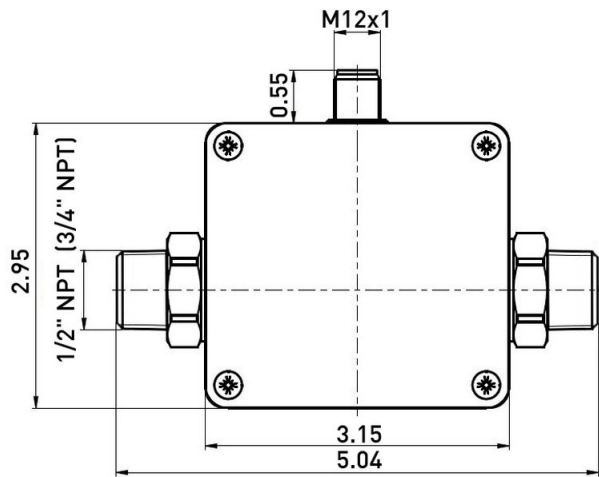

1/2" NPT only for MFS-2X.

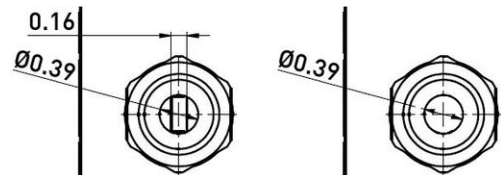
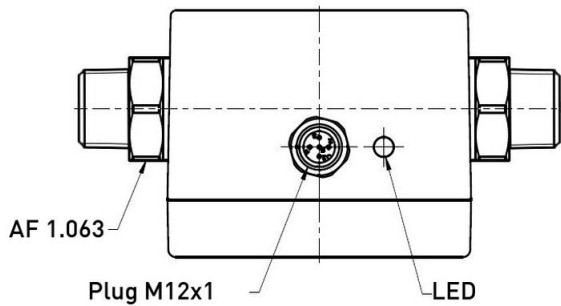

The cross section of the MFS-2X does not taper to 0.16 in.

MFS-3X:

