



# CONNECTION BULLETIN

## ***Vogt Valves***

Forged Steel  
Flow Control Valves

*FCD VVABR1015-00 – 01/05 (Replaces CB-15)*

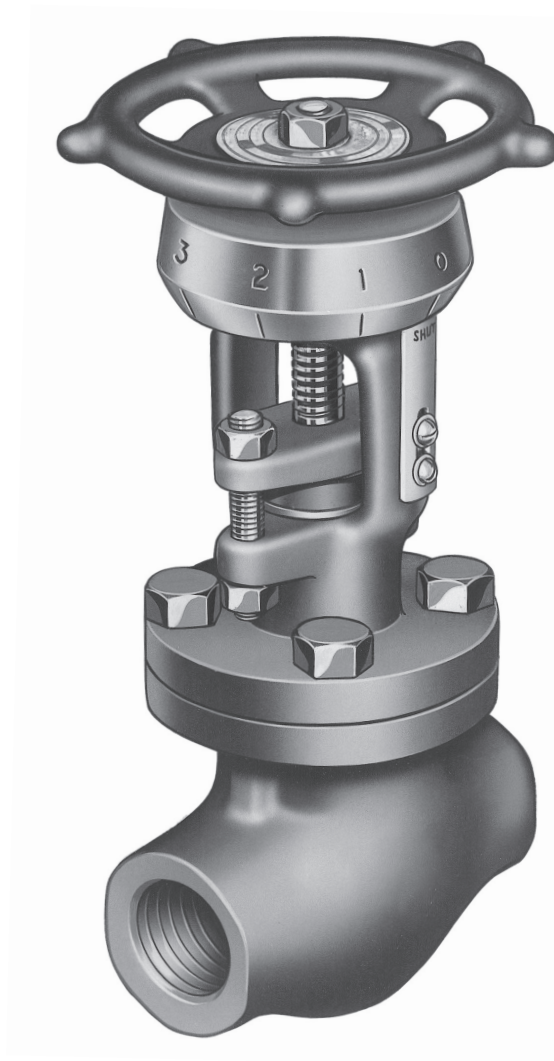

***Experience In Motion***

# Forged Steel Flow Control Valves

- Accurate Flow Regulation
- Positive Shutoff

## The Connection for Forged Steel Flow Control Valves

Flowserve Vogt Valves V-Port valve is particularly suited for “Continuous Blowdown” applications in power plants and “Speed Control” applications in hydraulic systems. The design of the valve ensures positive flow regulation without sacrificing the shutoff capability expected of a globe valve.

The V-Port flow control valves have specially designed discs for combination shutoff and throttling service. The shutoff and throttling surfaces are completely removed from each other in such a manner to insure that consistent flow rates are achieved during operation and that the shutoff seating surface is not subjected to the high velocities that occur at the throttling surface.

The discs are designed with an extended cylinder, which has V-shaped slots. As the disc is raised, the flow area at the V-shaped slots is increased, achieving regulation. The extended V-Port disc legs are fully guided in the valve body during full lift, ensuring minimum vibration of the disc.

Flow area generation at the disc throttling and seating surfaces are controlled to insure that a linear flow characteristic is achieved. Flow is directly proportional to the valve lift for a constant pressure drop. A stainless steel dial and indicator permit the operator to accurately regulate and duplicate the flow to a desired volume.

The  $C_v$  factors (see definition, page 6) are listed for the valves in the full open position.  $C_v$  factors at intermediate valve openings can be determined by multiplying the full open  $C_v$  factor by the ratio of the desired turns opening to turns full open.

Pressure drop or flow rates can be obtained for the Flowserve Vogt flow control valves by use of the  $C_v$  factor at full or intermediate valve openings in the formulas in Table 2.

Vogt’s needle-point stem valve is specifically designed for those applications requiring flow regulation in the extreme low  $C_v$  range. A linear flow characteristic is not achieved with this valve design but repeatability and close regulation is assured. The solid stem design assures that the flow geometry is maintained at any valve setting and duplication can be achieved even at high pressure drops. This valve can be provided with a dial and indicator if required.

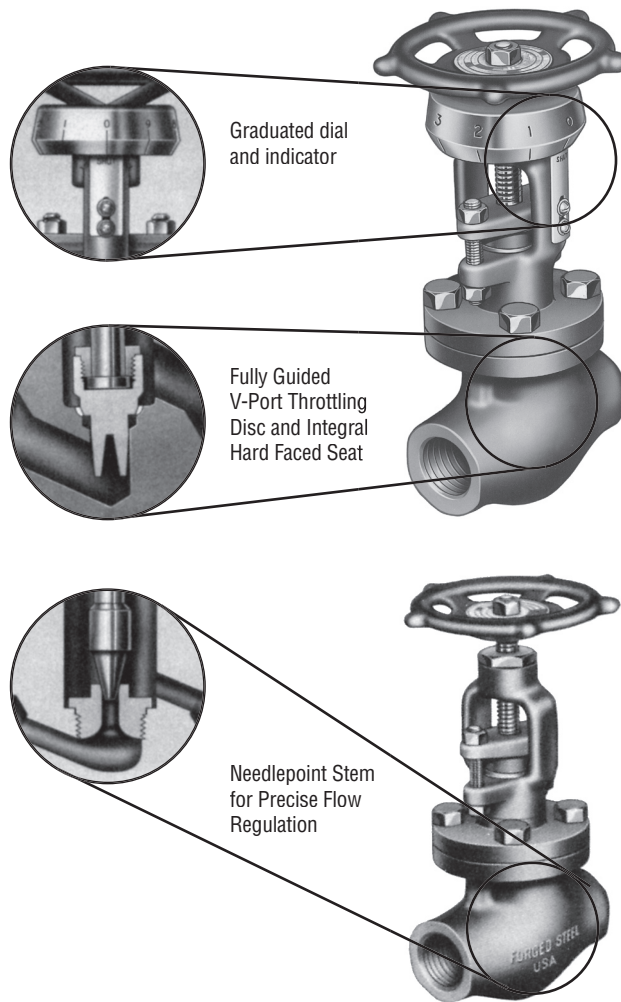

*Serving Worldwide Applications  
in Refineries, Chemicals,  
Power and Related Industries*

# Flow Capacities

## The Connection for Flow Control Valves in Continuous Blowdown Service

The following charts may be used to determine the flow anticipated for the Vogt V-Port valves when used in saturated water steam applications or continuous blowdown where a maximum “flashing condition” is expected.

Similar charts can be provided for other heat transfer fluids when desired.

Figure 1: Size 1/2, Series 12443, 15443

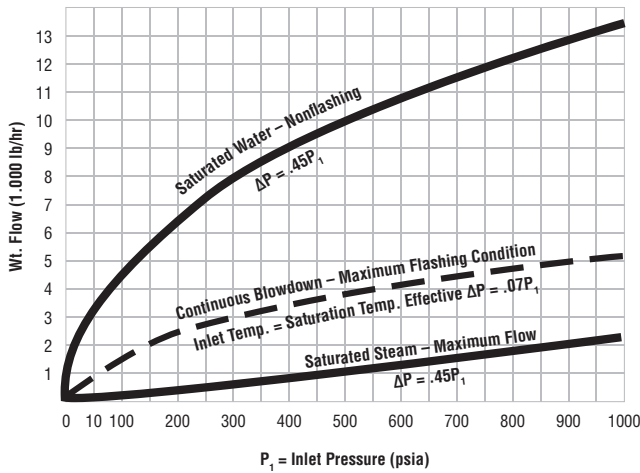

Figure 2: Size 3/4, Series 12443, 15443

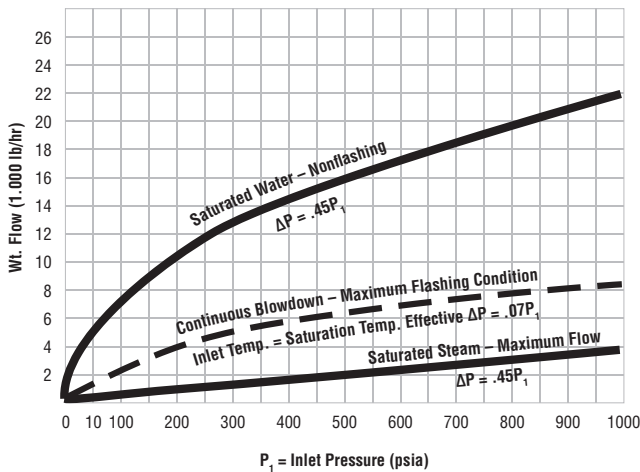

Figure 3: Size 1, Series 12443, 15443

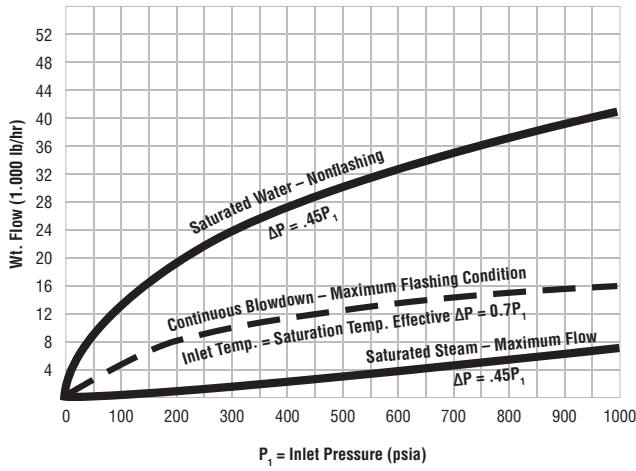

Figure 5: Size 1½, Series 15443

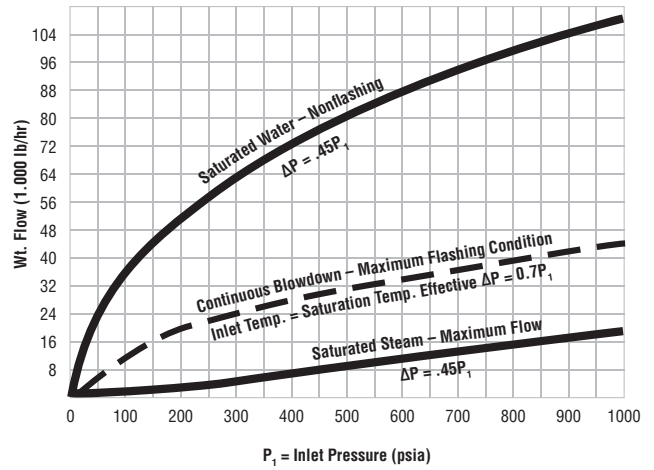

Figure 4: Size 1½, Series 12443

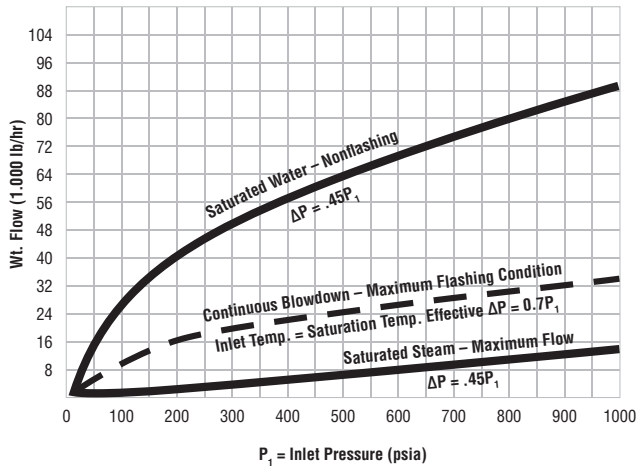
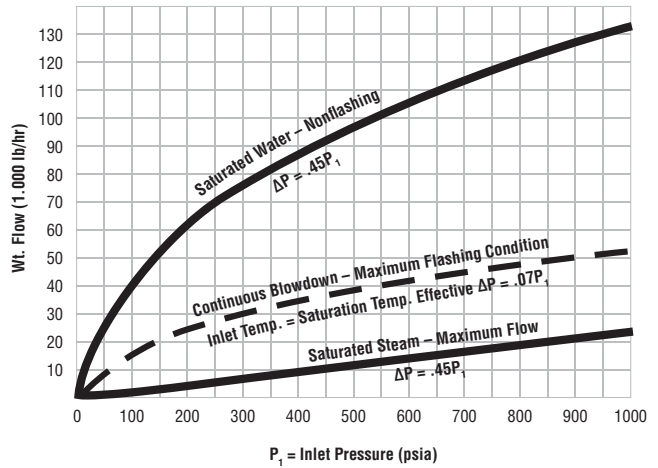

Figure 6: Size 2, Series 12443



## Correction Factors

Saturated Steam capacities (pounds per hour) from the preceding graphs are valid when the pressure drop across the valve is greater than 45% of the inlet pressure. For pressure drops less than 45% of the inlet pressure, multiply capacities by correction factor from Figure 7. For superheated steam, multiply saturated steam flow capacities from graphs by correction factor from Figure 8.

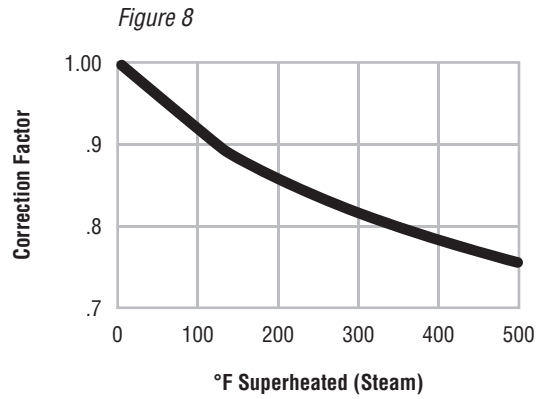
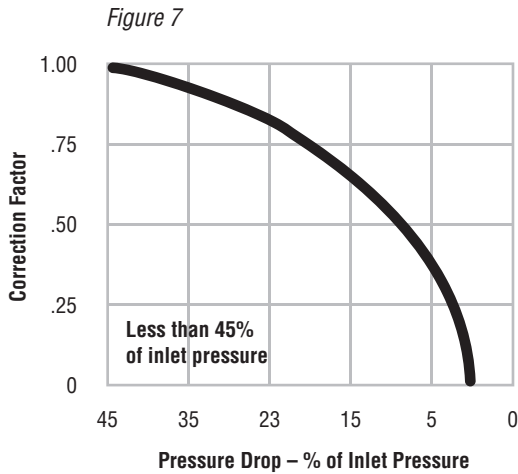

Table 1: Pressure/Temperature Ratings

Service Temperature (F°)	-20 to 100	200	300	400	500	600	650	700	750	800	850	900	950	1000
<b>Class 800</b>														
Carbon Steel A105 <sup>(1) (2)</sup>	1975	1810	1745	1690	1610	1515	1465	1415	1350	1100	850	615	365	225
<b>Class 1500</b>														
Carbon Steel A105 <sup>(1) (2)</sup>	3705	3395	3270	3170	3015	2840	2745	2655	2535	2055	1595	1150	685	430

<sup>(1)</sup> Ratings are in accordance with procedures in ASME B16.34, Standard Class.

<sup>(2)</sup> Permissible but not recommended for prolonged use above 800°F.

## C<sub>v</sub> Factors

This is the most common of flow coefficients in use today for the determination of valve flow capacity. It is defined as “the number of U.S. gallons per minute of water at 70°F which will flow through a valve at a pressure drop of one psi.” It can be used for liquids other than water and gas flow calculations.

Table 2: Flow Formulas Utilizing C<sub>v</sub> Factors

Type of Flow	Flow Rate	Pressure Drop
Liquid	$Q = C_v \sqrt{\frac{\Delta P}{S}}$	$\Delta P = S \left(\frac{Q}{C_v}\right)^2$
Gas	where $\Delta P < .5P_1$ $q^1m = 22.6 C_v \sqrt{\frac{\Delta P \times P_1}{T_1 Sg}}$	$\Delta P = \frac{.00195 T_1 Sg (q^1m)^2}{P_1 (C_v)^2}$
	where $\Delta P > .5P_1$ $q^1m = \frac{13.9 P_1 C_v}{\sqrt{Sg T_1}}$	
Dry Saturated Steam	where $\Delta P < .5P_1$ $W = 2.97 C_v \sqrt{\Delta P \times P_1}$	$\Delta P = \frac{.113 (W)^2}{P_1 (C_v)^2}$
	where $\Delta P > .5P_1$ $W = 1.82 C_v P_1$	
Superheated Steam	where $\Delta P < .5P_1$ $\frac{W = 2.97 C_v \sqrt{\Delta P \times P_1}}{(1 + .0007s)}$	$\Delta P = \frac{.113 (W(1 + .0007s))^2}{P_1 (C_v)^2}$
	where $\Delta P > .5P_1$ $W = \frac{1.82 C_v P_1}{(1 + .0007s)}$	
Flashing Mixtures of Water and Steam. <b>NOTE:</b> For $\Delta P$ , use minimum of actual $\Delta P$ or $\Delta P_{EFF}$	$W = 500 C_v \sqrt{S\Delta P}$	$\Delta P_{EFF} = [.07 + 0.022(t_s - t_1)^{-.70}] P_1$ for $(t_s - t_1)$ less than 120°F.

Fluid Flow Nomenclature	
<b>C<sub>v</sub></b>	Flow coefficient for valves and fittings.
<b>P<sub>1</sub></b>	Absolute inlet pressure. (psia)
<b>P<sub>2</sub></b>	Absolute outlet pressure. (psia)
<b>ΔP</b>	Pressure drop in pounds per square inch. (psi)
<b>ΔP<sub>EFF</sub></b>	Effective pressure drop in pounds per square inch. (psi)
<b>Q</b>	Liquid flow in gallons per minute (gpm)
<b>q<sup>1</sup>m</b>	Rate of gas flow in cubic feet per minute at standard conditions, 14.7 psia and 60°F. (scfm)
<b>S</b>	Specific gravity of flowing liquid relative to water at 60°F.
<b>Sg</b>	Specific gravity of gas relative to air.
<b>s</b>	Number of degrees of superheat for steam in °F.
<b>t</b>	Temperature in °F.
<b>T<sub>1</sub></b>	Absolute inlet temperature in Rankine. (R)
<b>t<sub>1</sub></b>	Actual inlet water temperature in °F.
<b>t<sub>s</sub></b>	Inlet water saturation temperature in °F.
<b>W</b>	Steam or vapor flow rate in pounds per hour. (lb/hr)

Figure 9: C<sub>v</sub> Factor vs Turns to Open (Flowserve Vogt V-Port Values)

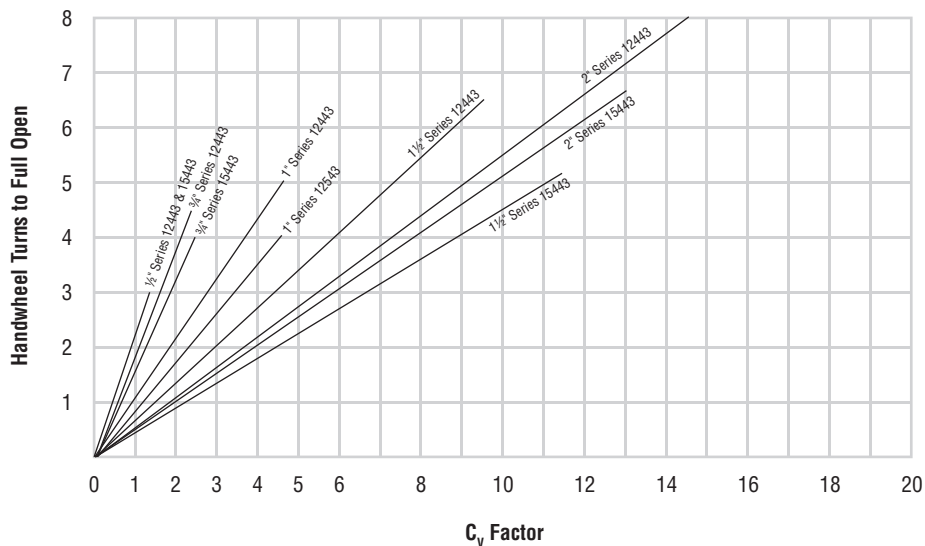

**NOTE:** C<sub>v</sub> Factors at intermediate-to-full opening range, shown in the accompanying graph, are valid for all liquids having viscosity near that of water at 60°F and specific gravity of 1.

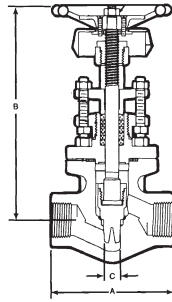
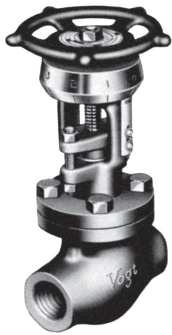

**Series 12443 & 15443**

- Loose V-Port Disc
- Dial and Indicator
- Round Bolted Bonnet
- Spiral-Wound Gasket
- Outside Screw and Yoke
- Bolted Gland
- Integral Hard-Faced Seat
- ASME B16.34

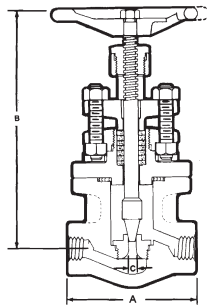
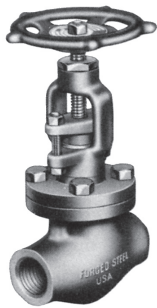

**Series 22461**

- Needle-Point Stem
- Round Bolted Bonnet
- Spiral-Wound Gasket
- Outside Screw and Yoke
- Bolted Gland
- Renewable Seat
- ASME B16.34

Table 2: Ordering Sizes and Series Numbers

	Pressure Class	Series Number		Material		Valve Size	Weight (lb.)	A	B	C	C <sub>v</sub> * Factor (in.)	Turns Full Open (Approx.)
		Threaded	Socket Weld	Body/Bonnet	Trim			End-to-End (in.)	Center-to-Top (open) (in.)	Seat Dia. (in.)		
Series 12443 and 15443	Class 800 1975 psi @ 100°F	12443	SW 12443	Carbon Steel A105	13% Cr. ★	½	5.14	3.75	6.81	.38	1.46	3
						¾	5.39	4.00	6.81	.44	2.38	4½
						1	9.50	4.62	8.44	.62	4.54	5
						1½	19.0	6.25	10.38	.94	9.65	6½
	Class 1500 3705 psi @ 100°F	15443	SW 15443	Carbon Steel A105	13% Cr. ★	½	10.8	4.50	7.88	.44	1.46	3
						¾	10.4	4.50	7.88	.44	2.38	4½
						1	21.5	6.25	10.12	.62	4.54	5
						1½	35.5	7.75	11.00	.94	11.50	5¼
Series 22461	Class 800 1975 psi @ 100°F	22461	SW 22461	Carbon Steel A105	13% Cr.	¼	4.80	3.75	6.69	.19	.56	3½
						⅜	4.59	3.75	6.69	.19	.55	3½
						½	5.00	3.75	6.69	.19	.68	3½
						¾	4.85	4.00	6.69	.19	.99	3½
						1	8.63	4.62	8.62	.25	1.50	5½

★ Integral hard-faced seat.

\*C<sub>v</sub> factors are for Vogt standard 4 V-port disc. 2 V-port discs can be furnished in standard flow control valves. Their Cv factors can be determined approximately by dividing the listed C<sub>v</sub> factors by 2, i.e., 1.414. Special flow control valves having C<sub>v</sub> factors less than 1 are available upon request.



**United States**  
Flowserve Corp.  
Flow Control  
Flowserve Vogt Valves  
1511 Jefferson Street  
Sulphur Springs, TX 75482 USA  
Telephone: 903-885-3151  
Fax: 903-439-3386

FCD VVABR1015-00 Printed in USA. (Replaces CB-15)

***To find your local Flowserve representative:***

For more information about Flowserve Corporation, visit  
[www.flowserve.com](http://www.flowserve.com) or call USA 1 800 225 6989

Flowserve Corporation has established industry leadership in the design and manufacture of its products. When properly selected, this Flowserve product is designed to perform its intended function safely during its useful life. However, the purchaser or user of Flowserve products should be aware that Flowserve products might be used in numerous applications under a wide variety of industrial service conditions. Although Flowserve can (and often does) provide general guidelines, it cannot provide specific data and warnings for all possible applications. The purchaser/user must therefore assume the ultimate responsibility for the proper sizing and selection, installation, operation, and maintenance of Flowserve products. The purchaser/user should read and understand the Installation Operation Maintenance (IOM) instructions included with the product, and train its employees and contractors in the safe use of Flowserve products in connection with the specific application.

While the information and specifications contained in this literature are believed to be accurate, they are supplied for informative purposes only and should not be considered certified or as a guarantee of satisfactory results by reliance thereon. Nothing contained herein is to be construed as a warranty or guarantee, express or implied, regarding any matter with respect to this product. Because Flowserve is continually improving and upgrading its product design, the specifications, dimensions and information contained herein are subject to change without notice. Should any question arise concerning these provisions, the purchaser/user should contact Flowserve Corporation at any one of its worldwide operations or offices.

© 2005 Flowserve Corporation, Irving, Texas, USA. Flowserve is a registered trademark of Flowserve Corporation.