



Worcester Controls Series 608 Ball Valve



Experience In Motion

Introducing a new 3-piece ball valve for services requiring API 608, such as downstream refiners and chemical companies. The design incorporates the stem design requirements of API 608 including torsional strength requirements.

Coupled with the superior Worcester seat design and a positive stem seal design, you are assured of high performance, high cycle life and excellent durability.

Additional options include API 607 4th edition fire safety, NACE compliance, metal seating options and multiple end connections. The valve is fully tested to API 598.

Lockout Device

Standard on all manual valves.

Gland Nut

Along with bellville washers adjusts packing pressure to compensate for normal wear and temperature fluctuations.

Stem

Large Diameter 17-4PH blowout-proof stem standard on both carbon steel and stainless steel valves.

Ball

Super smooth finish for low torque and long seat life. CF8M/316SS is standard for both carbon steel and stainless steel valves.

Stem And Body

Are continuously grounded to eliminate static discharge.

Body Gasket

PTFE standard. Grafoil® used for fire-sealed applications.

Seats

PTFE, Polyfill, High-Per Fill and Metal A and G seat options.



® Grafoil is a registered trademark of Union Carbide Corporation



Positive stem seal even after extended cycles

- Multi-element PTFE stem seals for unsurpassed seal life and cyclability
- Smooth stem finish reduces torque and increases stem seal life
- Glass filled PTFE thrust washer aids sealing while reducing torque
- Belleville springs maintain constant load on stem seals for high cycle life
- Stainless gland nut maintains packing compression through maximum operating temperature
- Double “D” stem positively indicates open or shut position

Variation (V-Numbered Options)

- V 3 Upstream Relief Hole
- V 6 Source Inspection
- V 20 Oxygen Service (½” – 2”)
- V 33 Oxygen Service w/o source Inspect. (½” – 2”)
- V 36 Certificate of Compliance
- V 37 Certificate of Compliance & Hydro Testing
- V 46 Silicone Free Lubricant
- V 58 B16.34 Compliance
- V 66 Certificate of Compliance for European Valve Orders

Worcester Controls Ball Valve 3-Piece Design, ANSI Class 600

½ in (15mm) - 2 in (50mm)

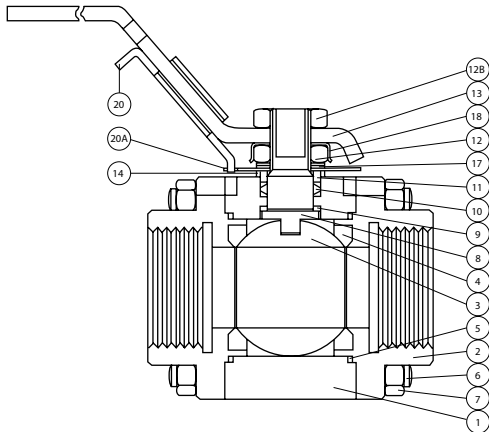

Item No.	Part Description	Valve Alloy	
		Stainless Steel	Carbon-Stainless Steel
1	Body	ASTM A182 Type 316 (FORGED)	ASTM A105 (FORGED) ASTM A350 LF2 (FORGED)
2	Pipe End	ASTM A182 Type 316	ASTM A105 (FORGED) ASTM A350 LF2 (FORGED)
3	Ball	ASTM A479-316 COND. A or ASTM A351 GR. CF8M	ASTM A479-316 COND. A or ASTM A351 GR. CF8M
4	Seat	High-Per-Fill	High-Per-Fill
		Polyfill	Polyfill
		Metal-G	Metal-G
5	Body Seal	Polytetrafluoroethylene - PTFE	Polytetrafluoroethylene - PTFE
		Grafoil (Firesafe Applications)	Grafoil (Firesafe Applications)
6	Body Bolt	ASTM A193 Gr. B8 CLASS 2	ASTM A193 GR. B7
7	Body Nut	ASTM A194 GR. 8	ASTM A194 GR. 2H
8	Stem	ASTM B564 H1150 (17-4PH SS)	ASTM B564 H1150 (17-4PH SS)
9	Stem Washer	Glass-Filled Polytetrafluoroethylene-GFPTFE	Glass-Filled Polytetrafluoroethylene-GFPTFE
10	Stem Seal	Polytetrafluoroethylene - PTFE	Polytetrafluoroethylene - PTFE
		Grafoil (Firesafe Applications)	Grafoil (Firesafe Applications)
11	Gland	SS 304	SS 304
12	Gland Nut	SS 304	SS 304
12B	Lever Nut	SS 304	Steel Plated
13	Lever	Stainless Steel	Stainless Steel
14	Antistatic Body Spring	SS 304	SS 304
17	Spring Disc	SS 304	EN 42 J
18	Lock Strip	SS 304	SS 304
20	Locking Plate	SS 304	SS 304

Ratings for Metal "A" and "G" and High-per Fill Seats

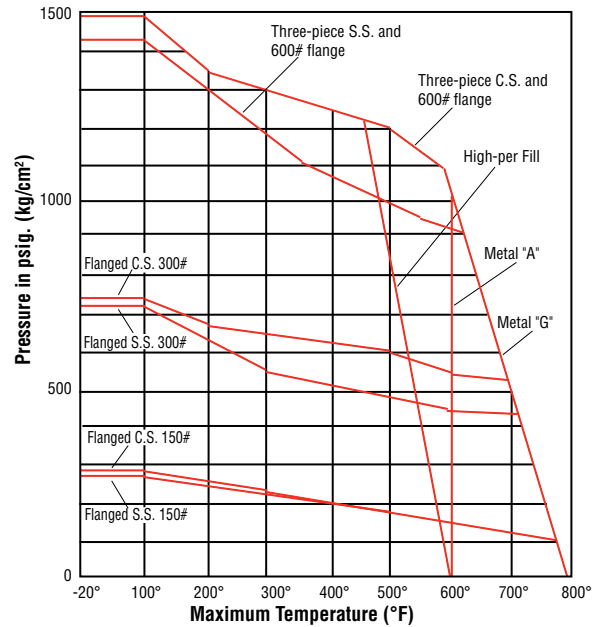

Ratings for Polyfill, RTFE, UHMWPE and TFE Seats

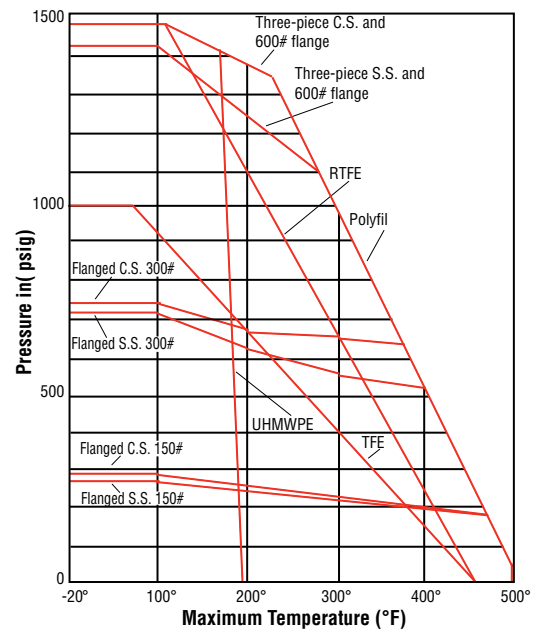



How to Order

Valve Size	Options	Port Options	Product Series	Body, Pipe Ends	Ball, Stem	Seat	Body Seal	Ends
1/4"	Blank – Built with lever handle	F – Full	608	4 – Carbon Steel	6 – 316 SS Ball	T – TFE	T – TFE	SE – Screwed Pipe Ends (NPT)
3/8"		R – Reduced		6 – 316 S.S.	17 – 4 Stem	R – Reinforced TFE	G – Graphite-coated S-gasket	Butt Weld ends:
1/2"	E – No handle			L – LF2		P – Polyfill	M – Teflon-coated S-gasket	BW4 – Carbon Steel, Sch. 40
3/4"	valve built for automation					X – High-Per Fill		BW4 – Stainless Steel, Sch. 40
1"						A – Metal A		SW – Socket Weld Ends
1 1/4"	Z – API 607 Firesafe					G – Metal G		
1 1/2"						Use only one letter if body seal is to be same material as seat		
2"								

**Variations (V-Numbered Options) see page 3 for listing. Leave blank if no variations.

Full ANSI B16.34 compliance requires a hydrotest and certified material test reports. Add V58 to ordering code if full B16.34 compliance is required.

Ordering Example (shown above): 1-1/4" Series 608 Full-Port valve with 316 S.S. body, ball and 17-4 PH stem, TFE seats and seals, and socket weld ends.

Polyfill® is a registered trademark of Flowserve Corporation.

High-Per Fill® is a registered trademark of Flowserve Corporation.

▲ CAUTION: Ball valves can retain pressurized media in the body cavity when closed.

Use care when disassembling. Always open valve to relieve pressure prior to disassembly.

Due to continuous development of our product range, we reserve the right to alter the dimensions and information contained in this leaflet as required.

To find your local Flowserve representative, visit www.flowserve.com or call USA 1 800 225 6989

**Flowserve Corporation
Flow Control**
1978 Foreman Drive
Cookeville, Tennessee 38501
Phone: 931 432 4021
Fax: 931 432 3105
www.flowserve.com

Flowserve Ahaus GmbH
Von Braun Straße 19a
D-48683 Ahaus
Germany
Phone: +49 2561 686-0
Fax: +49 2561 686-39

Flowserve Pte. Ltd.
12 Tuas Avenue 20
Republic of Singapore 638824
Phone: 65 862 3332
Fax: 65 862 2800

FCD WCENBR0065-01 Printed in USA.

Flowserve Corporation has established industry leadership in the design and manufacture of its products. When properly selected, this Flowserve product is designed to perform its intended function safely during its useful life. However, the purchaser or user of Flowserve products should be aware that Flowserve products might be used in numerous applications under a wide variety of industrial service conditions. Although Flowserve can (and often does) provide general guidelines, it cannot provide specific data and warnings for all possible applications. The purchaser/user must therefore assume the ultimate responsibility for the proper sizing and selection, installation, operation, and maintenance of Flowserve products. The purchaser/user should read and understand the Installation Operation Maintenance (IOM) instructions included with the product, and train its employees and contractors in the safe use of Flowserve products in connection with the specific application.

While the information and specifications contained in this literature are believed to be accurate, they are supplied for informative purposes only and should not be considered certified or as a guarantee of satisfactory results by reliance thereon. Nothing contained herein is to be construed as a warranty or guarantee, express or implied, regarding any matter with respect to this product. Because Flowserve is continually improving and upgrading its product design, the specifications, dimensions and information contained herein are subject to change without notice. Should any question arise concerning these provisions, the purchaser/user should contact Flowserve Corporation at any one of its worldwide operations or offices.

© 2006 Flowserve Corporation, Irving, Texas, USA. Flowserve is a registered trademark of Flowserve Corporation.