

Systempak (Digital/File Type) Potentiometer Conversion Module Model J-SPT 90/95

Introduction

The Potentiometer Conversion Module (J-SPT) accepts a change in resistance of potentiometer and converts it into a 1 to 5V DC or 4 to 20 mA DC output.

The J-SPT is available for one-output (J-SPT90) or two-output (J-SPT95) model. Settings such as linearization and filtering of inputs can be established responding to the application. Range settings and above optional functions are easily done with the dedicated Loader Software, which operates on a general-purpose PC.

Complete isolation is employed between the power, input, and output circuits. In the two-output model, isolation is also employed between the two output circuits.

Specification

- Input signal: Potentiometer (three-wire system)
- Input range: Total resistance; 100 ΩFS to 10 kΩFS
- Span: Within total resistance values
- Standard voltage: 0.5V DC or less
- Allowable wiring resistance:
10 Ω or less (Difference in resistance between three wires is within 0.5 Ω)
- Burnout signal: Upscale or Downscale (Specify when ordering.)
Slide detection only
- Burnout response:
Within 30 sec (Moving average available, first-order lag filtering: 0.1 sec)
- Output signal:
No. 1 output; 1 to 5V DC or 4 to 20 mA DC
No. 2 output; 1 to 5V DC (Between No. 1 and No. 2 outputs is isolated.)
Edge connector output; 1 to 5V DC (No. 1 output must be 1 to 5V DC when connecting the signal with the A-MC I/O cable.)
- Output impedance:
Voltage output; 250 Ω or less, Current output; 250 kΩ or more
- Allowable load resistance:
0 to 600 Ω (Current output: Up to +110%)
- Output update interval:
5 msec (Output hardware filtering 0 to 90% response, 50 msec)
- Output response:
Minimum of 160 msec, 0 to 90% response (Moving average and first-order lag filtering are not provided.)
- Accuracy:

Input span setting	Accuracy (for input span)
50% or more of input total resistance	±0.1%
50% or less of input total resistance	±0.1% × 50% / Input span for total resistance [%]

[Example]

Input total resistance (Potentiometer used)	Input span setting	Accuracy
1 kΩ	0 to 800 Ω	±0.1%
1 kΩ	100 to 900 Ω	±0.1%
1 kΩ	0 to 300 Ω	±0.1×50/30=±0.17%



- Insulation resistance: 500V DC, 100 MΩ min.
(Mutual between input - output - GND - power terminal)
- Withstand voltage: 1000V AC, 1 min
(Mutual between input - output - GND - power terminal)
- Power supply: 24V DC $^{+10}_{-15}$ %
- Current consumption: 130 mA or less (at 24V)
- Ambient temperature:
Normal operating condition; 5 to 45°C
Operation limit; 0 to 50°C
- Ambient humidity: 0 to 90%RH (No condensation allowed)
- Mounting: File
- Color of front mask: Black
- Weight: 250 g
- Operating influence:
Supply voltage effect; ±0.1%FS/24V DC $^{+10}_{-15}$ %
Temperature effect; ±0.15%FS/10°C
- Loader settings:
Module ID; 16 one-byte characters, 8 two-byte kanji characters
Potentiometer input range setting; Specify 0 and an input value by % corresponding to the span.
Linearization table; 101 points
Input filtering; Unavailable, available (Moving average)
Output zero span adjustment; -20 to +120%FS
First-order lag filtering; Without, with (0 sec to 20.0 sec, 63% response time)

Note: Burnout (Upscale, Downscale) is specified by hardware. Please specify it when ordering.
It will be set to Upscale unless otherwise specified.

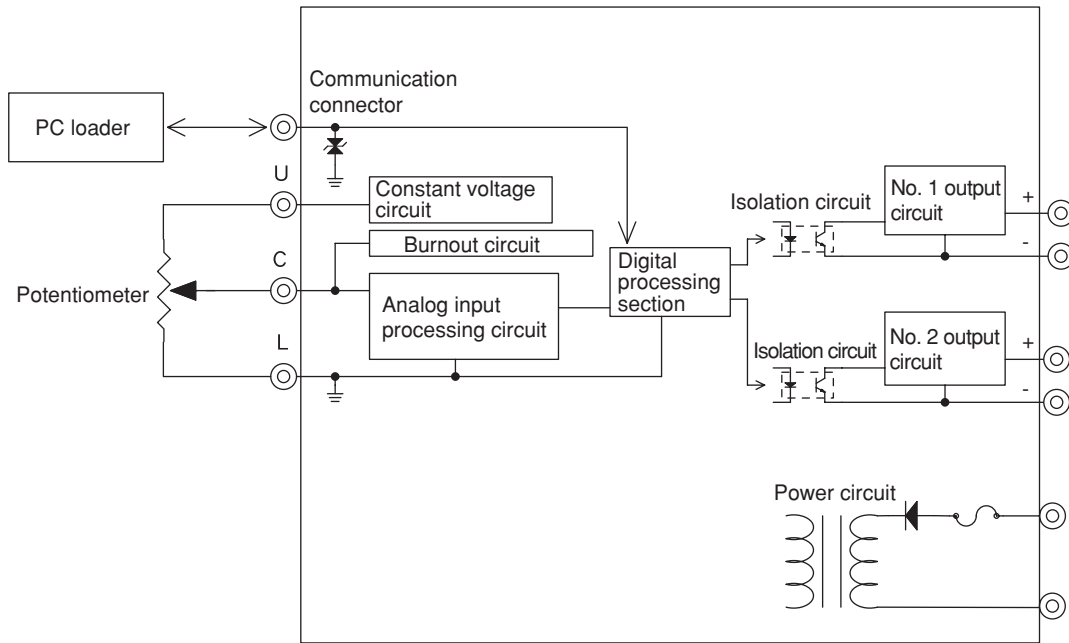

Figure 1. Functional block diagram of potentiometer conversion module

Model Number Table

One-output model

Basic model number	Selections		Additions	Description
	I	II	I	
J-SPT90				Potentiometer Conversion Module (one-output)
	X			No varnish coated
	C			Varnish coated
			-1	Input: Potentiometer
			1	Output: 1 to 5V DC
			2	Output: 4 to 20 mA DC
			-0	Without test report
			-1	With test report

Two-output model

Basic model number	Selections		Additions	Description
	I	II	I	
J-SPT95				Potentiometer Conversion Module (two-output)
	X			No varnish coated
	C			Varnish coated
			-1	Input: Potentiometer
			1	No. 1 output: 1 to 5V DC, No. 2 output: 1 to 5V DC
			2	No. 1 output: 4 to 20 mA DC, No. 2 output: 1 to 5V DC
			-0	Without test report
			-1	With test report

Example: J-SPT90C-12-1

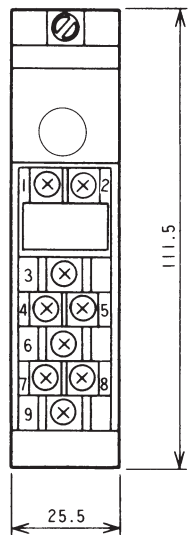
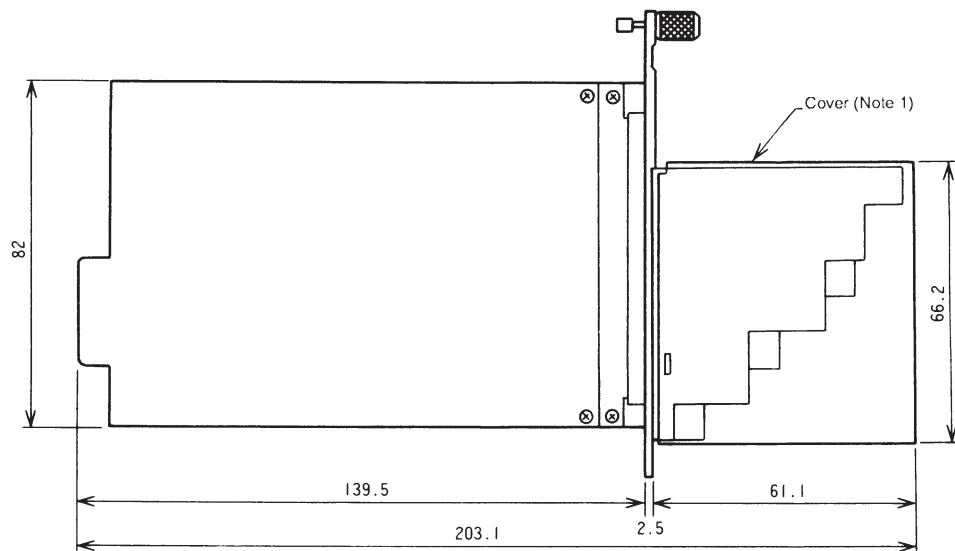

No.	Description	
1	Input U	U
2	Input L	L
3	Input C	c
4	No.1 output (+)	
5	No.1 output (-)	
6	No.2 output (+)	
7	No.2 output (-)	
8	—	
9	GND	

- Note
- 1) Operate the Module with a cover.
 - 2) Terminal screws: M3.5
 - 3) Use the pressured terminals with insulation sheath.

Figure 2. Dimensions and wiring diagram

When ordering, please specify:

1) Tag number

2) Input range*

[Set to 0 to 1000°C by default (0 to 50%, total resistance 2000 Ω)]

3) Burnout (Upscale, Downscale) [Set to Upscale by default]

The following are also set by default:

a) Input filtering: Moving average available

b) First-order lag filtering: Available, 0.1 sec

* Use the quick list below when specifying the range. Ranges other than those below are also accepted. Please also specify the total resistance.

Code No.	Input range
01	0 to 10%
02	0 to 20%
03	0 to 30%
04	0 to 40%
05	0 to 50%
06	0 to 60%
07	0 to 70%
08	0 to 80%
09	0 to 90%
10	0 to 100%

Please read the "Terms and Conditions" from the following URL before ordering or use:

<http://www.azbil.com/products/bi/order.html>

Specifications are subject to change without notice.



Azbil Corporation

Advanced Automation Company

1-12-2 Kawana, Fujisawa

Kanagawa 251-8522 Japan

URL: <http://www.azbil.com/>

2nd edition: Jan. 2013

No part of this publication may be reproduced or duplicated without the prior written permission of Azbil Corporation.