

**F4H9050/9200/9500/0002/
0005/0020
Compact Digital Mass Flow Controller
User's Manual
for
Installation and Configuration**



Thank you for purchasing an Azbil Corporation product.

This manual contains information for ensuring the correct use of this product. It also provides necessary information for installation, maintenance, and troubleshooting.

This manual should be read by those who design and maintain equipment that uses this product. Be sure to keep this manual nearby for handy reference.

Azbil Corporation

Please read “Terms and Conditions” from the following URL before ordering and use.

<http://www.azbil.com/products/factory/order.html>

NOTICE

Be sure that the user receives this manual before the product is used.

Copying or duplicating this user’s manual in part or in whole is forbidden. The information and specifications in this manual are subject to change without notice.

Considerable effort has been made to ensure that this manual is free from inaccuracies and omissions. If you should find an error or omission, please contact the azbil Group.

In no event is Azbil Corporation liable to anyone for any indirect, special or consequential damages as a result of using this product.

© 2017–2018 Azbil Corporation All Rights Reserved.

Modbus™ is a trademark and the property of Schneider Electric SE, its subsidiaries and affiliated companies.

Conventions Used in This Manual

- The safety precautions explained in the following section aim to prevent injury to the operator and others, and to prevent property damage.

 **WARNING** Warnings are indicated when mishandling this product might result in death or serious injury.

 **CAUTION** Cautions are indicated when mishandling this product might result in minor injury to the user, or only physical damage to the product.

- In describing the product, this manual uses the icons and conventions listed below.



Use caution when handling the product.



The indicated action is prohibited.



Always follow the indicated instructions.

Handling Precautions

Handling Precautions indicate items that the user should pay attention to when handling the F4H 9050/9200/9500/0002/0005/0020.



Note

Notes indicate information that might benefit the user.





This indicates the item or page that the user is requested to refer to.

(1), (2), (3):







Numbers within parentheses indicate steps in a sequence or parts of an explanation.

Safety Precautions















WARNING

-  Never allow a gas that is within explosive limits to pass through this device. Otherwise, an explosion may result.
-  To control the flow of oxygen, be sure to use the oxygen model. Do not use the oxygen model for gas that contains oil. If this should happen, never use the flow controller again for oxygen. The oil on parts that come into contact with the gas may catch fire.
-  Do not use this device in locations containing explosive gases or near flammable liquids or gases.

CAUTION

-  Prevent foreign matter from entering the flow path of this device. If rust, water droplets, oil mist, or dust from the pipes enters the device, a measurement or control error may occur, or the device may be damaged. If there is a possibility of foreign matter entering the device, install an upstream filter, strainer, or mist trap capable of eliminating foreign matter 0.1 μm and greater in diameter. Be sure to inspect and replace the filter at regular intervals.
-  Do not allow lint, metal shavings, water, etc., to enter the case of the device. Otherwise, a device malfunction or failure may result.
-  Do not subject the product to pressure beyond the rated pressure resistance range. Otherwise, damage to the product may result.
-  Be sure to use this device within the flow-rate range stipulated in the product specifications. To prevent excessive flow, use a suitable means to control the supply pressure or use a throttle valve or the like to control the flow rate. If the flow rate exceeds the upper limit, both the flow rate display and the output voltage/current may indicate lower values than the actual flow rate.
-  If damage could result from the abnormal functioning of this device, include appropriate redundancy in the system design.
-  When using this device for air-fuel ratio control of a burner, prevent the occurrence of flashback and also take countermeasures for the instrumentation to protect the device even if flashback occurs. A fire or an increase in pressure in the pipes caused by flashback from the burner will cause device failure.
-  Use this device within the operating differential pressure range. Failure to do so may result in hunting. Continuous hunting causes valve failure. It also may prevent the controlled flow rate from reaching the preset value.

CAUTION

 When controlling oxygen flow, use the oxygen model and follow the precautions below: <ul style="list-style-type: none">• The piping work should be carried out by a specialist with expertise in handling oxygen.• Use degreased pipes and parts.• Be sure to remove foreign matter, burrs, etc., from the pipes before connecting this device.
 Do not drop this device or subject it to impact. Otherwise, damage to this precision instrument may result.
 Mount this device securely so that it will not vibrate. Otherwise, a malfunction or failure may result.
 When mounting this device, make sure that the top panel does not face downward. If the top panel faces downward, device failure may result.
 When connecting the device to the pipes, hold the hexagonal part of the fitting in place and turn the pipe. After connecting the piping, check for gas leaks.
 If using Rc connections, exercise care not to use an excessive amount of sealant. Foreign matter or burrs in the pipes may result in measurement errors.
 Before connecting pipes with Swagelok or VCR fittings, check the instructions in the manual provided by the fitting manufacturer.
 Ensure that the wiring is correctly installed before turning the power on. Incorrect wiring may result in damage or malfunction.
 Do not apply excessive force to the connector or cables while the connector cable or AC adapter is connected. Otherwise, damage to the connector or circuit board may result.
 When disposing of this device, please observe local regulations.
 Do not connect equipment that causes a large throttling or pressure loss near the piping that is downstream of this device. Otherwise, hunting may result.
 When storing and transferring the device, place it in a plastic bag, etc., to prevent foreign matter from entering the flow path.
 If the device is installed in an environment subject to large temperature changes, introduce a flow of sufficiently dry gas through the pipes to remove any remaining wet gas in order to prevent water from condensing. Condensation may result in device malfunction.
 Do not blow air through the device or wipe the inside of the flow path with a rag.



CAUTION



Do not wash the device or steam-clean the inside of the flow path. Otherwise, a sensor malfunction may result.



Do not apply a negative voltage or a voltage exceeding 5 V to the flow rate setup input (+) terminal. Otherwise, a device malfunction or failure may result.



Always use the specified fittings and gaskets. After the piping work has been completed, check that there are no gas leaks before operating the device. Failure to do so may result in gas leakage.



The valve on this device cannot completely stop a flow. If complete shutoff is required, provide a separate shutoff valve. In addition, if an external shutoff valve is closed, fully close the valve of this device using either one of the following methods while it is standing by:

- Set the flow rate to zero.
- Set the operation mode to “valve fully closed.”

Even though the external shutoff valve is closed (flow rate is zero), leaving the device in control mode will cause a momentary excessive flow rate when the external shutoff valve is opened. Also, in control mode or with the valve forced fully open, if the external shutoff valve is kept closed, the valve overheating prevention function will be activated and the electrical current driving the valve will be forcibly limited.



If there is a risk of a lightning surge, use a surge absorber (surge protector). Failure to do so may result in a fire or device failure.



Do not turn off the power when settings are being written to EEPROM via RS-485 communication, when settings are being changed using the PC loader, or when the zero point adjustment switch is being used. Doing so might cause a problem.

The Role of This Manual

A total of 4 different manuals are available for the Compact Digital Mass Flow Controller (Model No.: F4H). Read them as necessary for your specific requirements. If a manual you require is not available, contact the azbil Group or its dealer.



F4H9050/9200/9500/0002/0005/0020 Compact Digital Mass Flow Controller User's Manual for Installation and Configuration **Manual No. CP-SP-1405E**

This manual.

This manual describes the hardware and all function of this unit.

Personnel in charge of design and/or manufacture of a system using this unit should read this manual thoroughly.

This manual covers mounting, connections for wiring, all functions and settings of this unit, operating procedures, troubleshooting, and detailed specifications.

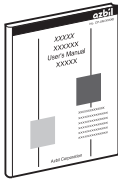

MLP300A000 Smart Loader Package for F4H-Series Compact Digital Mass Flow Controller User's Manual **Manual No. CP-SP-1415E**

Running the Smart Loader Package on a personal computer enables you to set the parameters of the F4H on the PC. This manual describes operations on the personal computer.

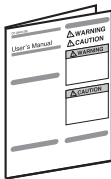

F4H9050/9200/9500/0002/0005/0020 Compact Digital Mass Flow Controller User's Manual **Manual No. CP-UM-5905JECK**

This manual is supplied with the product.

Personnel in charge of design and/or manufacture of a system using this unit should read this manual thoroughly.

This manual covers safety precautions, mounting, wiring, and main specifications. For more detailed information, see CP-SP-1405E.



F4H Series Compact Digital Mass Flow Controller User's Manual for RS-485 for Communication Functions **Manual No. CP-SP-1408E**

Those using the RS-485 communication functions should read this manual.

This manual gives an overview of communications, wiring, communication procedures, a list of F4H communication data, instructions on correcting problems, and communications specifications.

Copyrights, licenses, and registered trademarks

- Notice regarding the use of software licensed from ARM

This product includes software licensed from ARM Limited. The following information describes the conditions of the above-mentioned license and is not for the purpose of restricting your use of the product, etc.

Copyright © 2009–2015 ARM LIMITED All rights reserved.

Redistribution and use in source and binary forms, with or without modification, are permitted provided that the following conditions are met:

- Redistributions of source code must retain the above copyright notice, this list of conditions and the following disclaimer.
- Redistributions in binary form must reproduce the above copyright notice, this list of conditions and the following disclaimer in the documentation and/or other materials provided with the distribution.
- Neither the name of ARM nor the names of its contributors may be used to endorse or promote products derived from this software without specific prior written permission.

THIS SOFTWARE IS PROVIDED BY THE COPYRIGHT HOLDERS AND CONTRIBUTORS "AS IS" AND ANY EXPRESS OR IMPLIED WARRANTIES, INCLUDING, BUT NOT LIMITED TO, THE IMPLIED WARRANTIES OF MERCHANTABILITY AND FITNESS FOR A PARTICULAR PURPOSE ARE DISCLAIMED. IN NO EVENT SHALL COPYRIGHT HOLDERS AND CONTRIBUTORS BE LIABLE FOR ANY DIRECT, INDIRECT, INCIDENTAL, SPECIAL, EXEMPLARY, OR CONSEQUENTIAL DAMAGES (INCLUDING, BUT NOT LIMITED TO, PROCUREMENT OF SUBSTITUTE GOODS OR SERVICES; LOSS OF USE, DATA, OR PROFITS; OR BUSINESS INTERRUPTION) HOWEVER CAUSED AND ON ANY THEORY OF LIABILITY, WHETHER IN CONTRACT, STRICT LIABILITY, OR TORT (INCLUDING NEGLIGENCE OR OTHERWISE) ARISING IN ANY WAY OUT OF THE USE OF THIS SOFTWARE, EVEN IF ADVISED OF THE POSSIBILITY OF SUCH DAMAGE.

- Notice regarding the use of software licensed from STMicroelectronics

This product includes software licensed from STMicroelectronics. The following information describes the conditions of the above-mentioned license and is not for the purpose of restricting your use of the product, etc.

COPYRIGHT© 2014 STMicroelectronics

Redistribution and use in source and binary forms, with or without modification, are permitted provided that the following conditions are met:

1. Redistributions of source code must retain the above copyright notice, this list of conditions and the following disclaimer.
2. Redistributions in binary form must reproduce the above copyright notice, this list of conditions and the following disclaimer in the documentation and/or other materials provided with the distribution.
3. Neither the name of STMicroelectronics nor the names of its contributors may be used to endorse or promote products derived from this software without specific prior written permission.

THIS SOFTWARE IS PROVIDED BY THE COPYRIGHT HOLDERS AND CONTRIBUTORS "AS IS" AND ANY EXPRESS OR IMPLIED WARRANTIES, INCLUDING, BUT NOT LIMITED TO, THE IMPLIED WARRANTIES OF MERCHANTABILITY AND FITNESS FOR A PARTICULAR PURPOSE ARE DISCLAIMED. IN NO EVENT SHALL THE COPYRIGHT HOLDER OR CONTRIBUTORS BE LIABLE FOR ANY DIRECT, INDIRECT, INCIDENTAL, SPECIAL, EXEMPLARY, OR CONSEQUENTIAL DAMAGES (INCLUDING, BUT NOT LIMITED TO, PROCUREMENT OF SUBSTITUTE GOODS OR SERVICES; LOSS OF USE, DATA, OR PROFITS; OR BUSINESS INTERRUPTION) HOWEVER CAUSED AND ON ANY THEORY OF LIABILITY, WHETHER IN CONTRACT, STRICT LIABILITY, OR TORT (INCLUDING NEGLIGENCE OR OTHERWISE) ARISING IN ANY WAY OUT OF THE USE OF THIS SOFTWARE, EVEN IF ADVISED OF THE POSSIBILITY OF SUCH DAMAGE.

Contents

Conventions Used in This Manual

Safety Precautions

The Role of This Manual

Copyrights, licenses, and registered trademarks

Chapter 1.	OVERVIEW	1-1
	■ Overview	1-1
	■ Features	1-1
	■ Model selection guide	1-3
Chapter 2.	NAMES AND FUNCTIONS OF EACH PART	2-1
	■ Top panel	2-1
	■ Main unit	2-1
Chapter 3.	MOUNTING AND WIRING	3-1
3-1	Mounting	3-4
	■ Installation location	3-4
	■ Installation method	3-4
	■ Piping	3-6
3-2	Wiring	3-7
	■ Connector for external connection	3-7
	■ Communications connector (RS-485)	3-8
	■ Wiring	3-8
	■ Wiring Examples	3-9
Chapter 4.	BASIC SETTING	4-1
	■ Operation Mode	4-1
	■ Function for controlling the flow rate (SP)	4-1
	■ Flow rate setup by analog signal	4-1
	■ Flow rate setup by communication	4-2
	■ About control range and setup range	4-2
	■ Regarding operation outside the control range	4-2
	■ Selection function for valve operation	4-3
	■ Gas type selection function	4-3
	■ LED indication	4-4
	■ Communication functions	4-4
Chapter 5.	DETAILED SETTING	5-1
5-1	Function Code Settings	5-1
	■ Function code settings	5-1

5-2	Parameter Settings	5-9
	■ Parameter code settings	5-9
5-3	Other Detailed Setting	5-13
	■ SP ramp control function	5-13
	■ Zero point adjustment (when hydrogen/He gas is used)	5-14
	■ Multipoint flow rate correction	5-15
	■ Flow rate range change function	5-16
	■ Resolutions after changing range	5-17
	■ Functions related to maintenance	5-31
Chapter 6.	TROUBLESHOOTING	6-1
	■ Operation at alarm/event occurrence	6-1
	■ Other problems	6-4
Chapter 7.	Specifications	7-1
	■ F4H9050/9200/9500/0002/0005/0020	7-1
	■ Applied voltage and maximum differential pressure (air) for F4H0020	7-4
	■ Korean KC mark	7-5
	■ Relationship between differential pressure and flow rate when the valve is fully open (for air)	7-6
	■ Optional parts (sold separately)	7-7
	■ External Dimensions	7-8

Chapter 1. OVERVIEW

■ Overview

This device is a high-performance compact digital mass flow controller with advanced functions for the general industrial market. It features high speed and wide range flow rate control.

This product incorporates a Micro Flow sensor, which is an extremely high-speed response flow speed sensor developed by Azbil Corporation, a proportional solenoid valve, and advanced actuator control technology in order to achieve high-speed control.

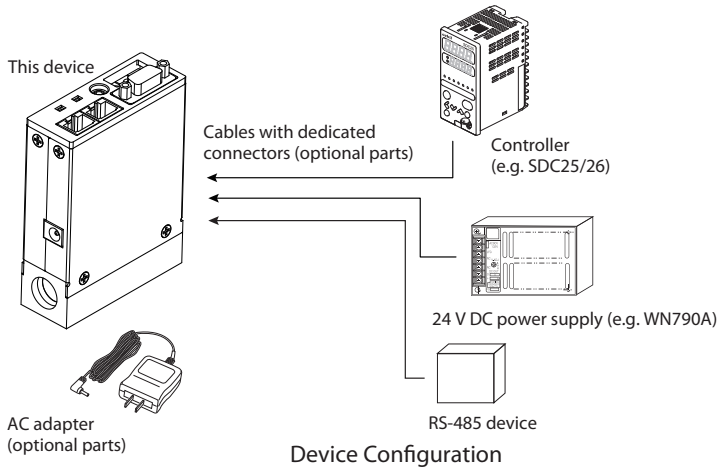

■ Features

- High-speed controllability
A high-speed response of 0.3 seconds* is realized.
* When control begins from the fully closed state or when the setting is changed during control, the controlled flow rate reaches the set value $\pm 2\%$ within 0.3 s.
- Wide control range
Provides a wide control range of 1 to 100 % full scale (FS).
(For F4H9050, 2 to 100 % FS)

- Ease of use

Product runs on 24 V DC from a single general-purpose power supply. In addition, the power supply circuit and the input/output circuit in this device are isolated.

When multiple F4Hs are driven through analog input/output using a programmable logic controller (PLC) or the like, even if the analog module channels on the PLC side are not isolated, a common power supply can be used to power this device. Even without using an individual power supply for each device, there is no need for concern regarding effects from one circuit on adjacent ones.

In addition, for the case of simple use in a laboratory, a convenient AC adapter (optional) is available.

■ Model selection guide

● SUS316 Air/nitrogen model

Basic model No.	Standard flow rate range	Flow path material	Piping connection method	Gas type	Communication type	O-ring material	Default gas type setting	Option 1	Option 2	Option 3	Appended No.	Remarks	
F4H												Compact Digital Mass Flow Controller	
	9050											1.00 to 50.00 [mL/min]*	
	9200											2.0 to 200.0 [mL/min]*	
	9500											5.0 to 500.0 [mL/min]*	
	0002											0.020 to 2.000 [L/min]*	
	0005											0.050 to 5.000 [L/min]*	
	0020											0.20 to 20.00 [L/min]*	
			6										SUS316 (with degreasing of gas-contacting parts)
				U									UNF (female thread is cut into the main unit)
				T									Rc fitting
				S									Swagelok fitting or equivalent
				V									VCR fitting or equivalent
					N								Air/nitrogen
						2							RS-485 CPL model
						3							RS-485 Modbus RTU model
							0						Fluoroelastomer
								N					Factory setting: Air/nitrogen
									0				No optional functions
										0			No optional functions
											0		No optional functions
										D		Inspection certificate	
										Y		Inspection certificate + traceability certification	
											0	Product version	

* Flow rate range for air, nitrogen, and argon.

● SUS316 Oxygen model

Basic model No.	Standard flow rate range	Flow path material	Piping connection method	Gas type	Communication type	O-ring material	Default gas type setting	Option 1	Option 2	Option 3	Appended No.	Remarks	
F4H												Compact Digital Mass Flow Controller	
	9050											1.00 to 50.00 [mL/min]*1	
	9200											2.0 to 200.0 [mL/min]*1	
	9500											5.0 to 500.0 [mL/min]*1	
	0002											0.020 to 2.000 [L/min]*1	
	0005											0.050 to 5.000 [L/min]*1	
	0020											0.20 to 20.00 [L/min]*1	
			6										SUS316 (with degreasing of gas-contacting parts)
				U									UNF (female thread is cut into the main unit)
				T									Rc fitting
				S									Swagelok fitting or equivalent
				V									VCR fitting or equivalent
					S								Oxygen
						2							RS-485 CPL model
						3							RS-485 Modbus RTU model
							0						Fluoroelastomer
								S					Factory setting: oxygen
									0				No optional functions
										0			No optional functions
											0		No optional functions
										D		Inspection certificate	
										Y		Inspection certificate + Traceability certification	
											0	Product version	

* Flow rate range for air, nitrogen, argon, and oxygen.

Chapter 2. NAMES AND FUNCTIONS OF EACH PART

■ Top panel

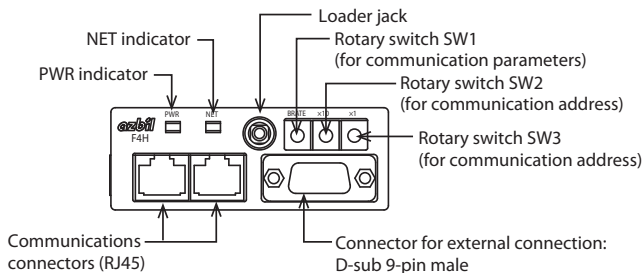

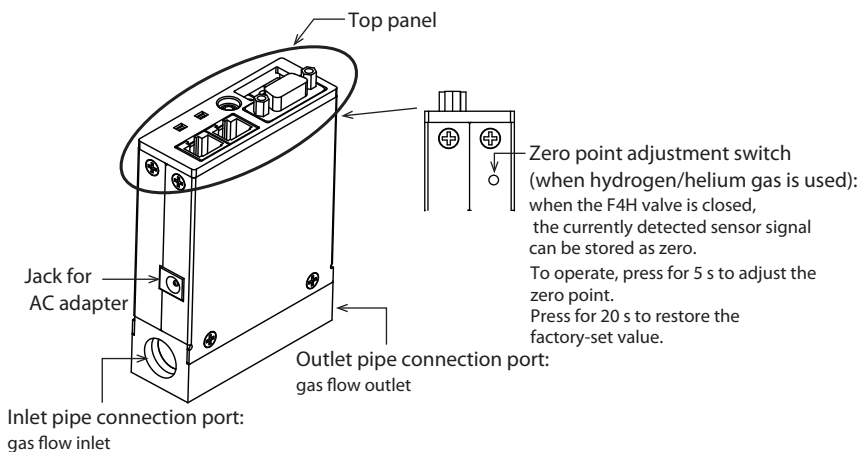

■ Main unit









Memo

Chapter 3. MOUNTING AND WIRING













WARNING

-  Never allow a gas that is within explosive limits to pass through this device. Otherwise, an explosion may result.
-  To control the flow of oxygen, be sure to use the oxygen model. Do not use the oxygen model for gas that contains oil. If this should happen, never use the flow controller again for oxygen. The oil on parts that come into contact with the gas may catch fire.
-  Do not use this device in locations containing explosive gases or near flammable liquids or gases.







CAUTION

-  **Prevent foreign matter from entering the flow path of this device.** If rust, water droplets, oil mist, or dust from the pipes enters the device, a measurement or control error may occur, or the device may be damaged. If there is a possibility of foreign matter entering the device, install an upstream filter, strainer, or mist trap capable of eliminating foreign matter 0.1 µm and greater in diameter. Be sure to inspect and replace the filter at regular intervals.
-  Do not allow lint, metal shavings, water, etc., to enter the case of the device. Otherwise, a device malfunction or failure may result.
-  Do not subject the product to pressure beyond the rated pressure resistance range. Otherwise, damage to the product may result.
-  **Be sure to use this device within the flow-rate range stipulated in the product specifications.** To prevent excessive flow, use a suitable means to control the supply pressure or use a throttle valve or the like to control the flow rate. If the flow rate exceeds the upper limit, both the flow rate display and the output voltage/current may indicate lower values than the actual flow rate.
-  **If damage could result from the abnormal functioning of this device, include appropriate redundancy in the system design.**
-  **When using this device for air-fuel ratio control of a burner, prevent the occurrence of flashback and also take countermeasures for the instrumentation to protect the device even if flashback occurs.**
A fire or an increase in pressure in the pipes caused by flashback from the burner will cause device failure.
-  **Use this device within the operating differential pressure range.** Failure to do so may result in hunting.
Continuous hunting causes valve failure. It also may prevent the controlled flow rate from reaching the preset flow rate.

 **CAUTION**

-  **When controlling oxygen flow, use the oxygen model and follow the precautions below:**
 - **The piping work should be carried out by a specialist with expertise in handling oxygen.**
 - **Use degreased pipes and parts.**
 - **Be sure to remove foreign matter, burrs, etc., from the pipes before connecting this device.**
-  **Do not drop this device or subject it to impact.**
Otherwise, damage to this precision instrument may result.
-  **Mount this device securely so that it will not vibrate.**
Otherwise, a device malfunction or failure may result.
-  **When mounting this device, make sure that the top panel does not face downward. If the top panel faces downward, device failure may result.**
-  **When connecting the device to the pipes, hold the hexagonal part of the fitting in place and turn the pipe.**
After connecting the piping, check for gas leaks.
-  **If using Rc connections, exercise care not to use an excessive amount of sealant. Foreign matter or burrs in the pipes may result in measurement errors.**
-  **Before connecting pipes with Swagelok or VCR fittings, check the instructions in the manual provided by the fitting manufacturer.**
-  **Ensure that the wiring is correctly installed before turning the power on.**
Incorrect wiring may result in damage or malfunction.
-  **Do not apply excessive force to the connector or cables while the connector cable or AC adapter is connected.**
Otherwise, damage to the connector or circuit board may result.
-  **When disposing of this device, please observe local regulations.**
-  **Do not connect equipment that causes a large throttling or pressure loss near the piping that is downstream of this device.**
Otherwise, hunting may result.
-  **When storing and transferring the device, place it in a plastic bag, etc., to prevent foreign matter from entering the flow path.**
-  **If the device is installed in an environment subject to large temperature changes, introduce a flow of sufficiently dry gas through the pipes to remove any remaining wet gas in order to prevent water from condensing.**
Condensation may result in device malfunction.

CAUTION

- 
 Do not blow air through the device or wipe the inside of the flow path with a rag.
- 
 Do not wash the device or steam-clean the inside of the flow path. Otherwise, a sensor malfunction may result.
- 
 Do not apply a negative voltage or a voltage exceeding 5 V to the flow rate setup input (+) terminal. Otherwise, a device malfunction or failure may result.
- 
 Always use the specified fittings and gaskets. After the piping work has been completed, check that there are no gas leaks before operating the device. Failure to do so may result in gas leakage.
- 
 The valve on this device cannot completely stop a flow. If complete shutoff is required, provide a separate shutoff valve. In addition, if an external shutoff valve is closed, fully close the valve of this device using either one of the following methods while it is standing by:
 - Set the flow rate to zero.
 - Set the operation mode to "valve fully closed."
 Even though the external shutoff valve is closed (flow rate is zero), leaving the device in control mode will cause a momentary excessive flow rate when the external shutoff valve is opened. Also, in control mode or with the valve forced fully open, if the external shutoff valve is kept closed, the valve overheating prevention function will be activated and the electrical current driving the valve will be forcibly limited.
- 
 If there is a risk of a lightning surge, use a surge absorber (surge protector). Failure to do so may result in a fire or device failure.

3 - 1 Mounting

■ Installation location

Install the device in a location not subject to the following:

- High or low temperature and/or humidity
- Sudden temperature changes that result in condensation
- Corrosive and/or flammable gases
- Large amounts of dust, salt, iron powder or other conductive substances in the atmosphere, or water droplets, oil mist, or organic solvents
- Direct vibration or shock
- Direct sunlight, wind, or rain
- Splashing of fluids, such as oil or chemicals
- Sources of electrical noise
- Strong magnetic or electrical fields

■ Installation method

CAUTION



When mounting, be sure to secure the product sufficiently so that it does not vibrate.

Otherwise, a device failure may result.

Using the mounting screw holes on the base of the device, mount using two M4 screws.

Unit: mm

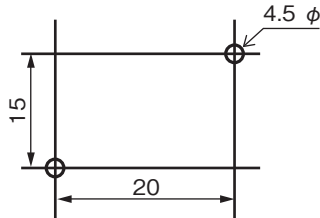

● Attaching the fitting (on a UNF connection)

⚠ CAUTION



When attaching the fitting (on a UNF connection), hold the lower part of the main unit in a vise gripped between rags to protect the finished surfaces, and turn the fitting to tighten.

If the lower part of the main unit is not held in place, it may be damaged.

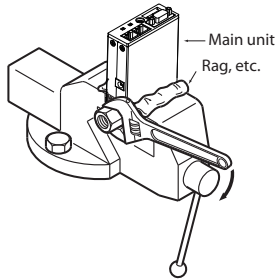

⚠ Handling Precautions

- When tightening the fitting, do not hold the upper part of the main unit by hand. Otherwise, deformation and damage may result.

Incorrect

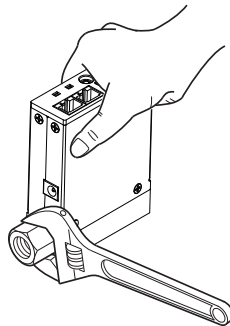

- Screw in the fittings with the correct torque recommended by the fitting manufacturer. Applying excessive torque may damage the connecting part.
- When connecting a commercially available quick-connect fitting, etc., to the Rc fitting, apply an appropriate amount of sealant. Do not put sealant on the first thread at the tip. In addition, remove any dust and burrs from inside the fitting.

Right

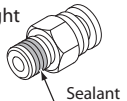

Wrong





 **Note**

- When purchasing a fitting, use the following products made by Ihara Science Co., Ltd:
 1/4 Swagelok or equivalent: DCU4-6SS (O-ring material: NBR)
 DCU4-6SS T-98694
 (degreased; O-ring material: fluoroelastomer)
- 1/4 VCR or equivalent: VTCU4-6 32
 (degreased; O-ring material: fluoroelastomer)

■ **Piping**

 **CAUTION**

-  **When connecting the device to the pipes, hold the hexagonal part of the fitting in place and turn the pipe.**
After connecting the piping, check for gas leaks.
-  **If using Rc connections, exercise care not to apply excessive sealant. Foreign matter or burrs in the pipes may result in measurement errors.**

 **Handling Precautions**

- Make sure that gas will flow in the  direction displayed on the main unit. If the gas direction is reversed, the flow rate cannot be controlled correctly.
- Do not touch the degreased gas-contacting parts with bare hands. Doing so will degrade the degreasing treatment.



- Do not hold the top part of the main unit with your hand when connecting the piping. Otherwise, deformation and damage may result.

● **Application of sealant (on Rc connections)**

 **Handling Precautions**

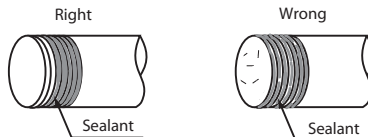

- Apply an appropriate amount of sealant. Do not put sealant on the two threads closest to the tip. In addition, remove any dust or burrs from the inside of the pipes.

3 - 2 Wiring

⚠ CAUTION

- ⊘ Do not apply a negative voltage or a voltage exceeding 5 V to the external setup voltage input terminal. Otherwise, a device malfunction or failure may result.
- ! When using a relay for an external contact input and/or an external 3-way switching input, use a relay designed for microcurrents (with gold contacts). Failure to use a relay designed for microcurrents may result in malfunction due to poor contact.
- ! If there is a risk of a lightning surge, use a surge protector. Failure to do so may result in a fire or device failure.
- ! Ensure that the wiring is correctly installed before turning the power on. Incorrect wiring may result in damage or malfunction.
- ! Do not apply excessive force on the connector or cables while the connector cable or AC adapter is connected. Otherwise, damage to the connector or circuit board may result.

■ Connector for external connection

● Connector specifications

D-sub 9-pin (male)

● Pin layout

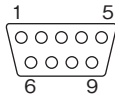

● Connector pin signal table

Pin No.	Signal	Description	Remarks
1	DI	External contact input (+)	-
2	FLOW RATE OUTPUT	Instantaneous flow rate output (+)	0-5 V, 1-5 V, or 4-20 mA output
3	POWER (24 V)	24 V DC power (+)	-
4	N.C.	-	-
5	POWER (GND)	24 V DC power (-)	-
6	FLOW RATE SP INPUT	Instantaneous flow rate setup input (+)	0-5 V, 1-5 V, or 4-20 mA input
7	A.GND	Instantaneous flow rate output (-) Instantaneous flow rate setup input (-)	Common ground for analog signals
8	D.GND	External contact input (-) Digital output 1 (-)	Common ground for digital signals
9	DO	Digital output (+)	Open collector output

Note: Even though the A.GND and D.GND are connected internally, be sure to ground them separately.

■ Communications connector (RS-485)

● Connector specifications

RJ-45

● Pin layout



87654321

● Connector pin signal table

Pin No.	Signal	Description
1	SG*	RS-485 communication SG
2	SG*	RS-485 communication SG
3	N.C	---
4	DB	RS-485 communication DB
5	DA	RS-485 communication DA
6	N.C	---
7	N.C	---
8	N.C	---

* SG is connected to A.GND and D.GND on the connector for external connection.

■ Wiring

● Power supply

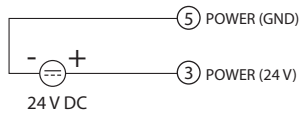

● Analog input/output

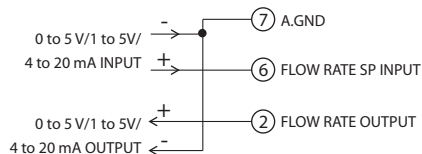

● External contact input

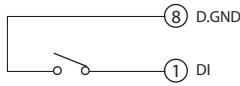

! Handling Precautions

- When switching by using relay contacts, use a relay designed for microcurrents (with gold contacts). Failure to use a relay designed for microcurrents may result in malfunction due to poor contact.

● Digital output

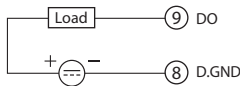

! Handling Precautions

- Be careful not to exceed the rated output of this device. In addition, when driving a relay, use a relay with built-in diode for absorbing coil surge.

■ Wiring Examples

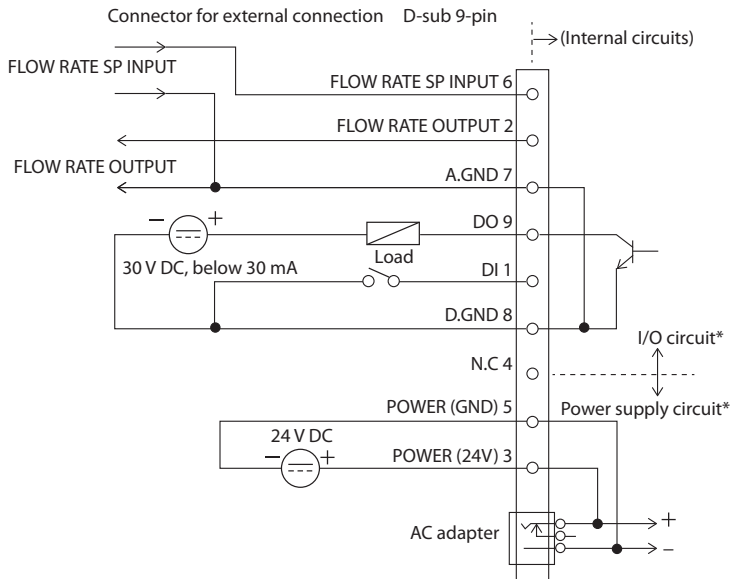

* The power supply circuit and I/O circuit are isolated.

Memo

Chapter 4. BASIC SETTING

■ Operation Mode

The following three operation modes are available.

- Fully closed mode: the valve is fully closed.
- Control mode: the flow rate is controlled to the set value.
- Fully open mode: the valve is fully open.

In control mode, the flow rate is controlled to the value that is set by analog signal or communication.

The selection of either analog signal or communication for setting is done by function setup.

The operation mode can be switched by the communication function.

 F4H Series Compact Digital Mass Flow Controller User's Manual for RS-485 for Communication Functions (CP-SP-1408E)

■ Function for controlling the flow rate (SP)

Using the "Flow rate (SP) setup method" function setting ($\zeta - 03$), you can select either analog (analog input signal) or digital (communication) as the setup method.

■ Flow rate setup by analog signal

If "1: Analog setup" is selected for function setup $\zeta - 03$, the set flow rate can be changed by an external analog signal.

Since the factory setting for $\zeta - 03$ is 1, control action is possible by inputting an analog signal (voltage or current) to the flow rate setup input.

By changing function setup $\zeta - 05$, the type of analog signal can be switched as shown below.

Function setup $\zeta - 05$	Input voltage/ current range	Voltage/current calculation formula for setting
0	0 to 5 V	Setup voltage [V] = Set flow rate / Full scale flow rate \times 5
1	1 to 5 V	Setup voltage [V] = Set flow rate / Full scale flow rate \times 4 + 1
2	4 to 20 mA	Setup current [mA] = Set flow rate / Full scale flow rate \times 16 + 4

In addition, you can switch to any scale by changing parameter setup $P - 17$.

You can change function settings and parameter settings through communication.

 F4H Series Compact Digital Mass Flow Controller User's Manual for RS-485 for Communication Functions (CP-SP-1408E)

In the case of flow rate setup by analog signal, set the input voltage/current within range.

Although there is some leeway in the range, the expected control performance may not be achieved outside the range.

■ Flow rate setup by communication

If "0: Digital setup" is selected for function setup $\zeta - 03$, the set flow rate can be changed by communication.

 F4H Series Compact Digital Mass Flow Controller User's Manual for RS-485 for Communication Functions (CP-SP-1408E)

■ About control range and setup range

The control range varies depending on the model number and the gas type selection.

 See note 1 in Chapter 7. Specifications ■ F4H9050/9200/9500/002/0005/0020 (P. 7-1)

The flow rate range can also be changed by using "Flow rate range" ($\zeta - 24$).

Please use within the range shown in sections  ■Flow rate range change function (P. 5-16) and ■Resolutions after changing range (P. 5-17) of Chapter 5. DETAILED SETTING.

■ Regarding operation outside the control range

When changing the settings by means of communication, if the set value is below the lower limit of the control range, control will not be carried out by the set value.

Device operation in such a case is as follows.

● In the case of F4H9050

- When a value from 2 % FS (control range lower limit) to 1 % FS is set, it is treated as 2 % FS.
- When a value from 1 % FS to 0 % FS is set, it is treated as 0 % FS.

● In cases other than F4H9050

- When a value from 1 % FS (control range lower limit) to 0.5 % FS is set, it is treated as 1 % FS.
- When a value from 0.5 % FS to 0 % FS is set, it is treated as 0 % FS.

■ Selection function for valve operation

● Forced valve open/close function

The valve can be forced fully opened or fully closed by selecting the operation mode at power-on or assigning the external contact input function.

For the settings,  the following functions listed under "■ Function code settings (P. 5-1)" in chapter 5.

- "Operation mode selection when power turned ON" (℄ - 02)
- "External contact input function" (℄ - 10).

● Automatic shutoff of valve

If "forced full close" is selected in "Operation selection at alarm/event occurrence," it can be used as an automatic shutdown function.

For the settings,  the following function listed under "■ Function code settings (P. 5-1)" in chapter 5.

- "Operation at alarm/event occurrence" (℄ - 15)

Handling Precautions

- Regarding "Forced full close"
The valve on this device cannot completely shut off a flow. If complete shutoff is required, provide a separate shutoff valve.

■ Gas type selection function

The gas type can be selected from air/nitrogen, oxygen (oxygen models only), argon, carbon dioxide, hydrogen, and helium using the "Gas type" function setting (℄ - 18). Be sure to set the gas type.

If any of the above gas types is selected, do not change the default value (1.000) of the "Conversion factor set by the user (C.F.)" parameter setting (P - 10).

Note

- The "Conversion factor set by the user (C.F.)" parameter setting (P - 10) is for the selected gas type. For a gas other than the above ones or a mixed gas, set the "Gas type" (℄ - 18) function setting and the "Conversion factor set by the user (C.F.)" parameter setting (P - 10) in accordance with the type of gas. Please contact us for the "Gas type" (℄ - 18) setting and the "Conversion factor set by the user (C.F.)" parameter setting (P - 10). (In some cases this product may not be compatible.)

■ LED indication

PWR indicator: Information not related to communication

	PWR indicator
At power-on (for approximately one second)	Green LED blinks quickly.
Zero-point calibration switch: zero-point adjusted	LED blinks twice.
Valve fully closed	Green LED blinks slowly.
Valve is being controlled	Green LED is lit
Valve fully open	Green LED blinks quickly.
Alarm (sensor failure)	Red LED is lit
Event	Orange LED blinks slowly

NET indicator: Information related to communication

	NET indicator
Communicating	Orange LED blinks slowly
Communication standby	Green LED is lit
Alarm for communication (serious failure such as hardware)	Red LED is lit
Alarm for communication (communication error)	Red LED blinks slowly

Note: Alarm / event ON/OFF information can be read through communication.

Note

-  F4H Series Compact Digital Mass Flow Controller User's Manual for RS-485 for Communication Functions (CP-SP-1408E)

■ Communication functions

● PC loader dedicated communication

The device is equipped with a port for PC loader dedicated communication. It can communicate with a PC one-on-one by using a dedicated tool (loader). (Operation, various settings and monitoring can be performed by communication.)

Please download the PC loader software (MLP300A000) from our website (COMPO CLUB) <http://www.compoclub.com>.

● RS-485 communication (CPL or Modbus-RTU communication)

3-wire RS-485 communication is used.

It is possible to communicate with a host device such as a PC or PLC using a communication program created by the user.

 Note

-  F4H Series Compact Digital Mass Flow Controller User's Manual for RS-485 for Communication Functions (CP-SP-1408E)

Memo

Chapter 5. DETAILED SETTING

5 - 1 Function Code Settings

The function code settings listed below can be changed by means of communication.

Note

-  F4H Series Compact Digital Mass Flow Controller User's Manual for RS-485 for Communication Functions (CP-SP-1408E)

■ Function code settings

Function code	Description	Setting No. and description	Initial value	Remarks
ℰ - 02	Operation mode at power-ON	0: Operation starts in control mode 1: Operation starts in the operating mode used before power was shut off 2: Operation starts in the fully closed mode	0	The operation mode when power is turned on can be selected.
ℰ - 03	Flow rate (SP) setup method	0: Digital setup (by communication) 1: Analog setup (by analog input signal)	1	 ■ Function for controlling the flow rate (SP) (P. 4-1)
ℰ - 05	Analog signal type	0: 0-5 V input/output 1: 1-5 V input/output 2: 4-20 mA input/output	0	The signal types for input and output are the same.
ℰ - 10	External contact input function	0: Disabled 5: When contact ON, forced full close; when contact OFF, forced full close is released 6: When contact ON, forced full open; when contact OFF, forced full open is released 7: SP ramp control setting switchover 8: Operation mode switchover (ON for control, OFF for fully open) 9: Flow rate zero adjustment 12: SP ramp control gradient switchover 13: Alarm reset	6	13: While contact is ON, all alarm detection is canceled. When the contact is turned OFF, alarm detection resumes.

Function code	Description	Setting No. and description	Initial value	Remarks
E - 18	Operation at alarm/event occurrence	0: Control continues and digital output is OFF when alarm/event occurs 1: Control continues and digital output is ON when alarm/event occurs 2: Forced full close and digital output is ON when alarm/event occurs 3: Forced full open and digital output is ON when alarm/event occurs 4: Control continues and digital output is ON when alarm occurs, control continues and digital output is OFF when event occurs 5: Forced full close and digital output is ON when alarm occurs, forced full close and digital output is OFF when event occurs 6: Forced full open and digital output is ON when alarm occurs, forced full open and digital output is OFF when event occurs 7: Control continues and digital output is ON when alarm occurs, control continues and digital output is OFF when event occurs 8: Forced full close and digital output is ON when alarm occurs, control continues and digital output is OFF when event occurs 9: Forced full open and digital output is ON when alarm occurs, control continues and digital output is OFF when event occurs	1	Even if "0" is selected, LED indicators operate. The behavior of settings 4 and 7 is identical. Related parameters P-03 - P-08, P-11, P-12  ■ Operation at alarm/event occurrence (P. 6-1)

Function code	Description	Setting No. and description	Initial value	Remarks
℄ - 18	Gas type	0: C.F. for gas type is set by the user 1: Air/Nitrogen (N ₂) 2: Oxygen (O ₂) Note: oxygen model only 3: Argon (Ar) 4: Carbon dioxide (CO ₂) 9: Hydrogen (H ₂) 10: Helium (He)	-	Initial value is set for the gas type of the product model. If the flow rate range changes due to a change in the gas type, the flow rate OK range and flow rate alarm range in the parameter setup must be changed. If "0" is selected, set the conversion factor set by the user (C.F.) in parameter setup mode. "2: Oxygen (O ₂)" can be set only on the oxygen model. Related parameters: P - 10, P - 23
℄ - 19	Flow rate standard condition	0: 20 °C 101.325 kPa (1 atm) 1: 0 °C 101.325 kPa (1 atm) 2: 25 °C 101.325 kPa (1 atm) 3: 35 °C 101.325 kPa (1 atm)	1	-
℄ - 20	Valve drive current alarm	0: Valve drive current alarm disabled 1: Only upper limit alarm enabled 2: Only lower limit alarm enabled 3: Upper and lower limit alarm enabled	0	The values for the upper and lower limit alarms are set in the parameter settings. Related parameters: P - 07, P - 11, P - 12
℄ - 23	PV filter (process for equalizing the instantaneous flow rate)*1	0: No PV filter 1: 2-sample moving average 2: 4-sample moving average 3: 8-sample moving average	0	If the PV filter is used at a "2" or "3" setting, the operational differential pressure must be lower than the standard differential pressure. Do not change the setting while control is in progress.

Function code	Description	Setting No. and description	Initial value	Remarks
ξ - 24	Flow rate range	0: Standard range 10-99:10-99 % of the standard range	0	<p>By reducing the flow rate range it is possible to improve the setting resolution. Note: See "Flow rate range change function" and "Resolutions after changing range" (page 5-12) for details. If a reduction rate of 10 to 99 is set, after range reduction calculation, the fraction is rounded in accordance with the resolution (it is rounded up if the fraction is half or more of the resolution, and is rounded off if the fraction is less than half of the resolution).</p> <p>Ex.) Model: F4H9500, gas type: oxygen, flow rate unit: mg/min According to the table on page 5-16, the standard range is 714.5 mg/min. If a reduction rate of 23 % is set, the calculation formula will be: $714.5 \times 0.23 = 164.335$ According to the table, the resolution after reduction is 0.2. When the value is separated into a valid value and a fraction, $164.335 = 164.2 + 0.135$ Since 0.135 (fraction) is more than half of the resolution, it is rounded up, and 164.4 will be the range after range reduction.</p>

Function code	Description	Setting No. and description	Initial value	Remarks
℄ - 27	SP ramp control	0: Disabled 1: SP ramp control type 1 (during SP ramp up, gradient 1, and during SP ramp down, gradient 2) 2: SP ramp control type 2 (during external contact OFF, gradient 1; during external contact ON, gradient 2)	0	It is possible to keep the gradient of change of the SP (set flow rate) constant at the start of control and when the SP is changed Gradients 1 and 2 are set in the parameter setup mode. Related parameters: P - 15, P - 16
℄ - 28	Optional analog scaling	0: Disabled 1: Enabled	0	The flow rate corresponding to 100 % analog input/output can be freely set to any value. Flow rate is set in the parameter setup mode. Related parameter: P - 17
℄ - 29	Low flow cutoff	0: Disabled 1: Enabled	0	After the flow rate is set to zero or the valve is set to fully closed mode, after a delay the low flow cutoff area is expanded. In this way zero point deviation of the instantaneous flow rate due to piping inclination, etc., can be ignored. The delay time is set in the parameter setup mode. Related parameter: P - 20
℄ - 30	Device address	0: Communication function is disabled 1-127: Device address	0	-
℄ - 31	Transmission speed	0: 38400 bps 1: 19200 bps 2: 9600 bps	1	-
℄ - 32	Data format	0: Even parity, 1 stop bit 1: Even parity, 2 stop bits 2: No parity, 1 stop bit 3: No parity, 2 stop bits 4: Odd parity, 1 stop bit 5: Odd parity, 2 stop bits	0	-

Function code	Description	Setting No. and description	Initial value	Remarks
ξ - 34	Piping orientation	0: Horizontal 1: Vertical (flow from bottom to top) 2: Vertical (flow from top to bottom)	0	In the case of "0" (Horizontal), characteristic correction is unnecessary, so characteristics are not corrected. For a setting of "1" or "2," the characteristics are corrected for vertical piping. Be sure to set P - 23 ("Primary pressure setting") and ξ - 18 ("Gas type"). These settings determine the amount of correction. Related parameters: P - 18, P - 23
ξ - 36	Control response	0: Emphasis on response 1: Standard 2: Emphasis on stability	1	The method of control can be optimized according to the actual operating environment. ("0" is used when a quicker response is desired, mainly at low differential pressure, and "2" is used when a slower response is desired at high differential pressure.)
ξ - 37	Flow rate display unit change function *2	0: L/min or mL/min 1: m ³ /h or L/h 2: g/min or mg/min 9: % FS	0	Related parameters P - 01 - P - 06, P - 17 Please note that changing the unit will switch the display of the above parameters automatically to the new unit.
ξ - 39	Zero point adjustment (when hydrogen/He gas is selected)	0: Do nothing 1: Adjust the zero-point	0	Note: Please use only for hydrogen/He gas. Correction is performed, and then it automatically returns to 0. Available only when the valve is fully closed.

Function code	Description	Setting No. and description	Initial value	Remarks
℄ - 40	PV communication data filter (process for equalizing instantaneous flow rate)*1	0: No PV filter 1: 4-sample moving average 2: 8-sample moving average 3: 16-sample moving average 4: Special filter N = 32 5: Special filter N = 64 6: Special filter N = 128 7: Special filter N = 256	3	For settings 1 to 3, the most recent PV values are averaged (ex.: for setting 1, "4-sample moving average," the four most recent PV values are averaged). For the special filters (settings 4 to 7), the average PV value is calculated using the following formula: $PV = \{PV + (N-1) \times PV'\} \div N$ where PV' is previous PV PV is the current PV N is the weight"
℄ - 41	Multipoint flow rate correction	0: Disabled 1: Enabled	0	Enables/disables the function for fine adjustment of the control flow rate according to a reference device. To use this function, select "1" (Enabled) and then set "Polygonal line correction X1 to Y4" from P-27 to P-34.
℄ - 42	Display resolution	0: Normal resolution 1: High resolution	0	By changing the resolution, flickering of the display can be minimized. Note: This setting does not affect the resolution of the analog output.

*1 Supplement to "PV filter (process for equalizing instantaneous flow rate)" (℄ - 23) and "PV communication data filter (process for equalizing instantaneous flow rate)" (℄ - 40)

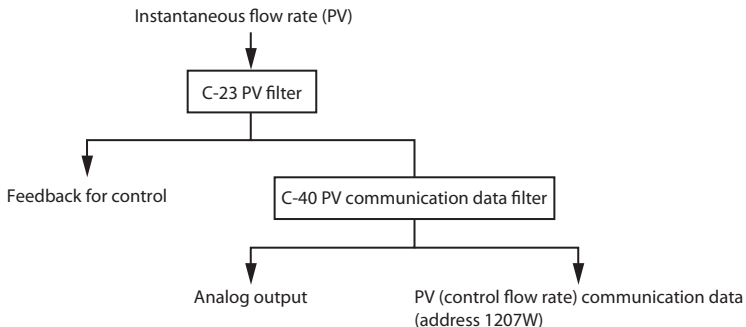

*2 Regarding the applied density selected by "2: g/min or mg/min" for "Flow rate display unit" (Ⓒ - 37), the density used for conversion varies depending on the gas type setting in "Gas type" (Ⓒ - 18).

Gas type (Ⓒ - 18)	Density
0: CF for the gas type is set by the user	(⒫ - 24) Converted to the density set by "Density for unit conversion (for user-set units)."
1: Air/nitrogen (N ₂)	1.2500 (density of nitrogen*)
2: Oxygen (O ₂) Note: oxygen model only	1.4290
3: Argon (Ar)	1.7840
4: Carbon dioxide (CO ₂)	1.9770
9: Hydrogen (H ₂)	0.0899
10: Helium (He)	0.1785

* When "Gas type" (Ⓒ - 18) is set to "1: Air/nitrogen" and "Flow rate display unit" (Ⓒ - 37) is set to "2: g/min or mg/min," conversion is based on the density of nitrogen (1.2500).
 If you want to convert using the density of air, set "Gas type" (Ⓒ - 18) to "0: CF for the gas type is set by the user" and set "Density for unit conversion (for user-set units)" (⒫ - 24) to the density of air (1.2930). In addition, use "Conversion factor set by the user" (⒫ - 18) with the initial value (1.000) unchanged.

5 - 2 Parameter Settings

The parameter code settings listed below can be changed by communication.

Note

-  F4H Series Compact Digital Mass Flow Controller User's Manual for RS-485 for Communication Functions (CP-SP-1408E)

■ Parameter code settings

Parameter code	Description	Initial value	Setting range	Related function settings	Remarks
P-01	Flow rate OK judgment range*1	(2 % FS)*6	(0.5 to 100.0 % FS)*6	-	Unit of measurement is set in ζ - 37.
P-02	Flow rate OK judgment Hysteresis*1	(1 % FS)*6	(0.5 to 100.0 % FS)*6	-	Unit of measurement is set in ζ - 37.
P-03	Instantaneous flow rate deviation upper limit alarm*2	(10 % FS)*6	(0.5 to 100 % FS)*6	ζ - 18	Unit of measurement is set in ζ - 37.
P-04	Instantaneous flow rate deviation upper limit alarm Hysteresis*2	(2 % FS)*6	(0.5 to 100 % FS)*6	ζ - 18	Unit of measurement is set in ζ - 37.
P-05	Instantaneous flow rate deviation lower limit alarm*2	(10 % FS)*6	(0.5 to 100 % FS)*6	ζ - 18	Unit of measurement is set in ζ - 37.
P-06	Instantaneous flow rate deviation lower limit alarm Hysteresis*2	(2 % FS)*6	(0.5 to 100 % FS)*6	ζ - 18	Unit of measurement is set in ζ - 37.
P-07	Instantaneous flow rate deviation alarm / valve drive current alarm judgment delay time	10.0 s	0.5 to 999.9 s	ζ - 18, ζ - 20	---
P-08	Digital output Delay time	0.0 s	0.0 to 999.9 s	ζ - 18	The time between alarm detection and output
P-10	Conversion factor set by the user*3	1.000	0.040 to 9.999	ζ - 18	---
P-11	Valve drive current Upper limit alarm*4	100.0 %	0.1 to 100 %	ζ - 18, ζ - 20	Alarm detection is OFF for the initial value.
P-12	Valve drive current Lower limit alarm*4	0.0 %	0.0 to 99.9 %	ζ - 18, ζ - 20	Alarm detection is OFF for the initial value.

Parameter code	Description	Initial value	Setting range	Related function settings	Remarks
P - 15	SP ramp control gradient 1	(0 % FS)*6	(0 to 500 % FS)*6	---	Sets the change in flow rate per second. If zero is set, gradient 1 is not applied to ramping.
P - 16	SP ramp control gradient 2	(0 % FS)*6	(0 to 500 % FS)*6	---	Sets the change in flow rate per second. If zero is set, gradient 2 is not applied to ramping.
P - 17	Optional analog scaling*5	(100 % FS)*6	(10 to 100 % FS)*6	ζ - 28	Sets the flow rate corresponding to 100 % analog input/output (5 V). Unit of measurement is set in ζ - 37.
P - 20	Low flow cutoff delay time	3.0 s	0.0 to 999.9 s	ζ - 29	---
P - 23	Primary pressure setting (for correcting vertical pressure)	200	0 to 500 kPa (gauge)	ζ - 18, ζ - 34	The setting is effective only if ζ - 34 is set to a vertical setting. This function is not available on model F4H9050. (Even if it is set, no correction will occur.)
P - 24	Density for unit conversion (for user-set units)	0.1000	0.0000 to 6.0000 kg/m ³	ζ - 18, ζ - 37	Sets the density used for conversion when "0: C.F. for the gas type is set by the user" is selected in ζ - 18 and "2: g/min or mg/min" is selected in ζ - 37.
P - 25	Amount of zero point adjustment	0	-2000 to +2000	ζ - 39	Check P - 25 to learn the result of zero adjustment.
P - 26	Low flow cutoff threshold (when valve closed)	50	0 to 100 % FS	---	Sets the low flow cutoff point for the instantaneous flow rate as a percentage of the full scale when the valve is forced fully closed or the control flow rate is set to zero.

Parameter code	Description	Initial value	Setting range	Related function settings	Remarks
P-27	Multipoint flow rate correction value X1	(25 % FS)	(5 to 45 % FS)	ζ-41	---
P-28	Multipoint flow rate correction value X2	(50 % FS)	(30 to 70 % FS)	ζ-41	---
P-29	Multipoint flow rate correction value X3	(75 % FS)	(55 to 95 % FS)	ζ-41	---
P-30	Multipoint flow rate correction value X4	(100 % FS)	(80 to 120 % FS)	ζ-41	---
P-31	Multipoint flow rate correction value Y1	(25 % FS)	(5 to 45 % FS)	ζ-41	---
P-32	Multipoint flow rate correction value Y2	(50 % FS)	(30 to 70 % FS)	ζ-41	---
P-33	Multipoint flow rate correction value Y3	(75 % FS)	(55 to 95 % FS)	ζ-41	---
P-34	Multipoint flow rate correction value Y4	(100 % FS)	(80 to 120 % FS)	ζ-41	-

*1 Operation of flow rate OK judgment

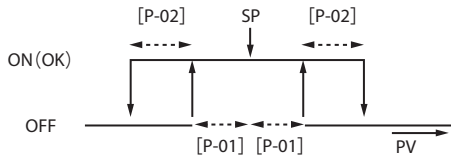

*2 Operation of flow rate deviation upper/lower limit alarm judgment

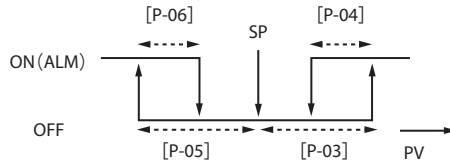

*3 Effective only when "0: User setting" is selected for the "Gas type" function setting (ζ-18).

If the "Conversion factor set by the user (C.F.)" (P-10) is set to less than 1, the control range will be reduced to the amount of the range × CF. Also, please note that even if you change the "Conversion factor set by the user (C.F.)" to 1 or larger, the upper limit of the control range will not increase.

*4 Only items corresponding to the alarm selected in "Valve drive current alarm" (ζ - 20) in the function settings are valid.

The valve drive current varies greatly depending on the differential pressure even at the same flow rate. The valve drive current alarm function cannot be used unless the differential pressure is stable.

Even if the differential pressure is stable, the hysteresis characteristics (drive current differs even at the same flow rate) affect the relationship between the valve drive current and the flow rate.

When using the valve drive current alarm, please check the valve drive current with sufficient testing under operating conditions before determining what alarm current to set.

*5 Effective only when "1: Enabled" is selected for "Optional analog scaling" (ζ - 28) in the function settings.

*6 The initial value and setting range are the full scale flow rate multiplied by the percentage in parentheses. (Setting range varies depending on model and gas type.)

Handling Precautions

- If you change the unit of measurement in "Flow rate display unit change function" (ζ - 37) in the function settings, the unit switches automatically to the changed unit. Before setting parameters, check the setting of ζ - 37.

5 - 3 Other Detailed Setting

■ SP ramp control function

SP ramp control consists of control types 1 and 2. Select the type in "SP ramp control" (ξ - 27).

● SP ramp control type 1

When the SP is rising, it is ramped at gradient 1, and when it is falling, it is ramped at gradient 2.

● SP ramp control type 2

The control gradients are switched by turning the external contact on/off.

Ramping is at gradient 1 while the external contact is OFF, and is at gradient 2 while the external contact is ON.

Note

- For the combination and operation of the "SP ramp control" (ξ - 27) and "External contact input function" (ξ - i3) settings, see the table below.

		(ξ - i3) External contact input function		
		0: Disabled	7:SP ramp control action (when ON, SP ramp control; when OFF, normal control)	12:SP ramp control gradient switchover
(ξ - 27) SP ramp control	0: Disabled	No function (Regardless of contact ON/OFF, normal control is in effect.)		
	1: SP ramp control type 1 (during SP ramp up, gradient 1; during SP ramp down, gradient 2)	SP ramp control type 1 operation (regardless of contact ON/OFF)	SP ramp control type 1 operation (When contacts are OFF, normal; when ON, ramp control)	-
	2: SP ramp control type 2 (when external contact OFF, gradient 1; when external contact ON, gradient 2)	-	-	SP ramp control type 2 operation (When contacts are OFF, gradient 1; when ON, gradient 2)

■ Zero point adjustment (when hydrogen/He gas is used)

When F4H valve is closed, the sensor signal currently detected can be recorded as zero. For hydrogen/He gas use, since the characteristics differ greatly from air/nitrogen, it is necessary to adjust the zero point.

! Handling Precautions

- Do not adjust the zero point for gas types other than hydrogen/He. If the zero point was adjusted accidentally, before using the device, restore the factory-set zero point by using the zero point adjustment switch on the main unit.
- After zero point adjustment, the adjusted value is recorded in the built-in nonvolatile memory, so it will be reflected in the operation the next time the main unit power is turned on.

Zero point initialization or zero point adjustment can be executed when the valve is fully closed (OFF) or when SP = 0 in Control mode.

● Adjusting the zero point

This can be done in the following three ways:

- Press the zero point adjustment switch on the side of the main unit for 5 seconds.
- Select "9: Flow rate zero adjustment" for "External contact input function" (㉔ - ㉕), and keep the external contact ON continuously for 10 seconds.
- Set "1: Adjust the zero point" for "Zero point adjustment" (㉔ - ㉙).

The amount of adjustment can be checked in "Amount of zero point adjustment" (㉙ - ㉚).

● To return "Amount of zero point adjustment" to the initial factory setting

Press the zero point adjustment switch on the side of the main unit for 20 seconds. The value will change to 0.

Note

-  Chapter 2. NAMES AND FUNCTIONS OF EACH PART (for the position of the zero point adjustment switch)

■ Multipoint flow rate correction

This function corrects the control flow rate when the SP value is set. It is intended for fine adjustment of the control flow rate according to a reference device.

● How to Use

Select "1: Enabled" for "Multipoint flow rate correction" ($\zeta - 44$) and then set Multipoint flow rate correction values X1 to Y4 ($P - 27$ to $P - 34$).

Each setting range for $P - 27$ to $P - 34$ is the full scale flow rate multiplied by the percentage in parentheses. (Setting range varies depending on model and gas type.)

● Application example

For model F4H9200, when "1: Air/nitrogen" is set for "Gas type" ($\zeta - 48$) and "0: L/min or mL/min" is set for "Flow rate display unit" ($\zeta - 37$), since the full scale flow rate is 200.0 mL/min, (100 % FS) is 200.0.

Now, suppose that the reference device reads 195.0 mL/min when model F4H9200 is controlled at SP = 200.0 mL/min (100 % FS).

If "195.0" is set for "Multi-point flow rate correction value Y4," control will be corrected so that the reading of the reference device is 200.0 when SP = 200.0 mL/min.

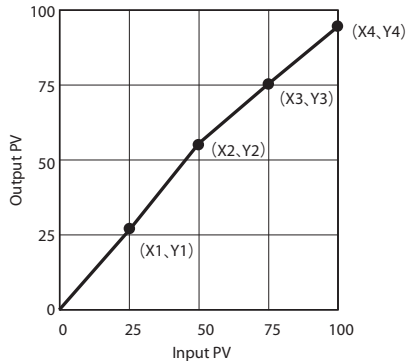

! Handling Precautions

- Set the polyline for monotonic increase. Otherwise, the operation will not be performed correctly. (A "multipoint flow rate correction data setting error" event will occur.)

■ Flow rate range change function

By changing the "Flow rate range" setting ($\zeta - 24$), the range can be reduced to 99 to 10 % of the standard range.

Note that the lower limit of the control range does not change.
(for the standard range of the F4H)

Note that even if the "Flow rate range" setting ($\zeta - 24$) is changed, the accuracy specification is the same as in the standard range

Example: For F4H0005 (standard range: 0.050–5.000 [L/min]) with "Gas type" ($\zeta - 18$) = 1 (Air/nitrogen) and "Display resolution" ($\zeta - 42$) = 0 (Normal resolution), if "Flow rate range" ($\zeta - 24$) is set to 40 %, the control range will be 0.050–2.000 L/min. The full scale flow rate will be 2.000 L/min, so the resolution will be 0.010 L/min (see "When the gas type is 1 (Air/nitrogen [N₂]), 2 (Oxygen [O₂]), or 3 (Argon [Ar])" in the next section).

■ Resolutions after changing range

● Unit of flow rate: L/min or mL/min

● When the gas type is "1: Air/nitrogen (N₂),"2: Oxygen (O₂),"or "3: Argon (Ar)!"

Normal resolution: "Display resolution" (ζ - 4ζ) is set to 0 (Normal resolution)

F4H9050		F4H9200		F4H9500	
Full scale flow rate [mL/min]	Resolution [mL/min]	Full scale flow rate [mL/min]	Resolution [mL/min]	Full scale flow rate [mL/min]	Resolution [mL/min]
50.00 to 30.20	0.20	---	---	500.0 to 302.0	2.0
30.00 to 12.10	0.10	200.0 to 121.0	1.0	300.0 to 121.0	1.0
12.00 to 6.05	0.05	120.0 to 60.5	0.5	120.0 to 60.5	0.5
6.00 to 5.00	0.02	60.0 to 30.2	0.2	60.0 to 50.0	0.2
---	---	30.0 to 20.0	0.1	---	---

F4H0002		F4H0005		F4H0020	
Full scale flow rate [L/min]	Resolution [L/min]	Full scale flow rate [L/min]	Resolution [L/min]	Full scale flow rate [L/min]	Resolution [L/min]
---	---	5.000 to 3.020	0.020	---	---
2.000 to 1.210	0.010	3.000 to 1.210	0.010	20.00 to 12.10	0.10
1.200 to 0.605	0.005	1.200 to 0.605	0.005	12.00 to 6.05	0.05
0.600 to 0.302	0.002	0.600 to 0.500	0.002	6.00 to 3.02	0.02
0.300 to 0.200	0.001	---	---	3.00 to 2.00	0.01

High resolution: "Display resolution" (ζ - 4ζ) is set to 1 (High resolution)

F4H9050		F4H9200		F4H9500	
Full scale flow rate [mL/min]	Resolution [mL/min]	Full scale flow rate [mL/min]	Resolution [mL/min]	Full scale flow rate [mL/min]	Resolution [mL/min]
50.00 to 20.05	0.05	---	---	500.0 to 200.5	0.5
20.00 to 10.02	0.02	200.0 to 100.2	0.2	200.0 to 100.2	0.2
10.00 to 5.00	0.01	100.0 to 20.0	0.1	100.0 to 50.0	0.1

F4H0002		F4H0005		F4H0020	
Full scale flow rate [L/min]	Resolution [L/min]	Full scale flow rate [L/min]	Resolution [L/min]	Full scale flow rate [L/min]	Resolution [L/min]
---	---	5.000 to 2.005	0.005	---	---
2.000 to 1.002	0.002	2.000 to 1.002	0.002	20.00 to 10.02	0.02
1.000 to 0.200	0.001	1.000 to 0.500	0.001	10.00 to 2.00	0.01

● When the gas type is "4: Carbon dioxide (CO₂)"

Normal resolution: "Display resolution" (☞ - ☞) is set to 0 (Normal resolution)

F4H9050		F4H9200		F4H9500	
Full scale flow rate [mL/min]	Resolution [mL/min]	Full scale flow rate [mL/min]	Resolution [mL/min]	Full scale flow rate [mL/min]	Resolution [mL/min]
30.00 to 12.10	0.10	---	---	300.0 to 121.0	1.0
12.00 to 6.05	0.05	120.0 to 60.5	0.5	120.0 to 60.5	0.5
6.00 to 3.02	0.02	60.0 to 30.2	0.2	60.0 to 30.2	0.2
3.00	0.01	30.0 to 12.0	0.1	30.0	0.1

F4H0002		F4H0005		F4H0020	
Full scale flow rate [L/min]	Resolution [L/min]	Full scale flow rate [L/min]	Resolution [L/min]	Full scale flow rate [L/min]	Resolution [L/min]
---	---	3.000 to 1.210	0.010	---	---
1.200 to 0.605	0.005	1.200 to 0.605	0.005	12.00 to 6.05	0.05
0.600 to 0.302	0.002	0.600 to 0.302	0.002	6.00 to 3.02	0.02
0.300 to 0.120	0.001	---	---	3.00 to 1.20	0.01

High resolution: "Display resolution" (☞ - ☞) is set to 1 (High resolution)

F4H9050		F4H9200		F4H9500	
Full scale flow rate [mL/min]	Resolution [mL/min]	Full scale flow rate [mL/min]	Resolution [mL/min]	Full scale flow rate [mL/min]	Resolution [mL/min]
30.00 to 20.05	0.05	---	---	300.0 to 200.5	0.5
20.00 to 10.02	0.02	120.0 to 100.2	0.2	200.0 to 100.2	0.2
10.00 to 3.00	0.01	100.0 to 12.0	0.1	100.0 to 30.0	0.1

F4H0002		F4H0005		F4H0020	
Full scale flow rate [L/min]	Resolution [L/min]	Full scale flow rate [L/min]	Resolution [L/min]	Full scale flow rate [L/min]	Resolution [L/min]
---	---	3.000 to 2.005	0.005	---	---
1.200 to 1.002	0.002	2.000 to 1.002	0.002	12.00 to 10.02	0.02
1.000 to 0.120	0.001	1.000 to 0.300	0.001	10.00 to 1.20	0.01

● When the gas type is "9: Hydrogen (H₂)"

Normal resolution: "Display resolution" (ζ - 42) is set to 0 (Normal resolution)

F4H9050		F4H9200		F4H9500	
Full scale flow rate [mL/min]	Resolution [mL/min]	Full scale flow rate [mL/min]	Resolution [mL/min]	Full scale flow rate [mL/min]	Resolution [mL/min]
---	---	800.0 to 605.0	5.0	---	---
---	---	600.0 to 302.0	2.0	---	---
200.0 to 121.0	1.0	300.0 to 121.0	1.0	2000 to 1210	10
120.0 to 60.5	0.5	120.0 to 80.0	0.5	1200 to 605	5
60.0 to 30.2	0.2	---	---	600 to 302	2
30.0 to 20.0	0.1	---	---	300 to 200	1

F4H0002		F4H0005		F4H0020	
Full scale flow rate [L/min]	Resolution [L/min]	Full scale flow rate [L/min]	Resolution [L/min]	Full scale flow rate [L/min]	Resolution [L/min]
8.000 to 6.050	0.050	---	---	---	---
6.000 to 3.020	0.020	---	---	60.00 to 30.20	0.20
3.000 to 1.210	0.010	20.00 to 12.10	0.10	30.00 to 12.10	0.10
1.200 to 0.800	0.005	12.00 to 6.05	0.05	12.00 to 6.05	0.05
---	---	6.00 to 3.02	0.02	6.00	0.02
---	---	3.00 to 2.00	0.01	---	---

High resolution: "Display resolution" (ζ - 42) is set to 1 (High resolution)

F4H9050		F4H9200		F4H9500	
Full scale flow rate [mL/min]	Resolution [mL/min]	Full scale flow rate [mL/min]	Resolution [mL/min]	Full scale flow rate [mL/min]	Resolution [mL/min]
---	---	800.0 to 200.5	0.5	---	---
200.0 to 100.2	0.2	200.0 to 100.2	0.2	2000 to 1002	2
100.0 to 20.0	0.1	100.0 to 80.0	0.1	1000 to 200	1

F4H0002		F4H0005		F4H0020	
Full scale flow rate [L/min]	Resolution [L/min]	Full scale flow rate [L/min]	Resolution [L/min]	Full scale flow rate [L/min]	Resolution [L/min]
8.000 to 2.005	0.005	---	---	60.00 to 20.05	0.05
2.000 to 1.002	0.002	20.00 to 10.02	0.02	20.00 to 10.02	0.02
1.000 to 0.800	0.001	10.00 to 2.00	0.01	10.00 to 6.00	0.01

● When the gas type is "10: Helium (He)"

Normal resolution: "Display resolution" (└ - 4┘) is set to 0 (Normal resolution)

F4H9050		F4H9200		F4H9500	
Full scale flow rate [mL/min]	Resolution [mL/min]	Full scale flow rate [mL/min]	Resolution [mL/min]	Full scale flow rate [mL/min]	Resolution [mL/min]
---	---	800.0 to 605.0	5.0	---	---
---	---	600.0 to 302.0	2.0	---	---
120.0 to 60.5	0.5	300.0 to 121.0	1.0	1200 to 605	5
60.0 to 30.2	0.2	120.0 to 80.0	0.5	600 to 302	2
30.0 to 12.0	0.1	---	---	300 to 120	1

F4H0002		F4H0005		F4H0020	
Full scale flow rate [L/min]	Resolution [L/min]	Full scale flow rate [L/min]	Resolution [L/min]	Full scale flow rate [L/min]	Resolution [L/min]
8.000 to 6.050	0.050	---	---	---	---
6.000 to 3.020	0.020	---	---	50.00 to 30.20	0.20
3.000 to 1.210	0.010	---	---	30.00 to 12.10	0.10
1.200 to 0.800	0.005	12.00 to 6.05	0.05	12.00 to 6.05	0.05
---	---	6.00 to 3.02	0.02	6.00 to 5.00	0.02
---	---	3.00 to 1.20	0.01	---	---

High resolution: "Display resolution" (└ - 4┘) is set to 1 (High resolution)

F4H9050		F4H9200		F4H9500	
Full scale flow rate [mL/min]	Resolution [mL/min]	Full scale flow rate [mL/min]	Resolution [mL/min]	Full scale flow rate [mL/min]	Resolution [mL/min]
---	---	800.0 to 200.5	0.5	---	---
120.0 to 100.2	0.2	200.0 to 100.2	0.2	1200 to 1002	2
100.0 to 12.0	0.1	100.0 to 80.0	0.1	1000 to 120	1

F4H0002		F4H0005		F4H0020	
Full scale flow rate [L/min]	Resolution [L/min]	Full scale flow rate [L/min]	Resolution [L/min]	Full scale flow rate [L/min]	Resolution [L/min]
8.000 to 2.005	0.005	---	---	50.00 to 20.05	0.05
2.000 to 1.002	0.002	12.00 to 10.02	0.02	20.00 to 10.02	0.02
1.000 to 0.800	0.001	10.00 to 1.20	0.01	10.00 to 5.00	0.01

● **Unit of flow rate: m³/h or L/h**

● **When the gas type is "1: Air/nitrogen (N₂)," "2: Oxygen (O₂)," or "3: Argon (Ar)"**

Normal resolution: "Display resolution" (ζ - 4ζ) is set to 0 (Normal resolution)

F4H9050		F4H9200		F4H9500	
Full scale flow rate [L/h]	Resolution [L/h]	Full scale flow rate [L/h]	Resolution [L/h]	Full scale flow rate [L/h]	Resolution [L/h]
3.000 to 1.210	0.010	---	---	30.00 to 12.10	0.10
1.200 to 0.605	0.005	12.00 to 6.05	0.05	12.00 to 6.05	0.05
0.600 to 0.302	0.002	6.00 to 3.02	0.02	6.00 to 3.02	0.02
0.300	0.001	3.00 to 1.20	0.01	3.00	0.01

F4H0002		F4H0005		F4H0020	
Full scale flow rate [m ³ /h]	Resolution [m ³ /h]	Full scale flow rate [m ³ /h]	Resolution [m ³ /h]	Full scale flow rate [m ³ /h]	Resolution [m ³ /h]
---	---	0.3000 to 0.1210	0.0010	---	---
0.1200 to 0.0605	0.0005	0.1200 to 0.0605	0.0005	1.200 to 0.605	0.005
0.0600 to 0.0302	0.0002	0.0600 to 0.0302	0.0002	0.600 to 0.302	0.002
0.0300 to 0.0120	0.0001	0.0300	0.0001	0.300 to 0.120	0.001

High resolution: "Display resolution" (ζ - 4ζ) is set to 1 (High resolution)

F4H9050		F4H9200		F4H9500	
Full scale flow rate [L/h]	Resolution [L/h]	Full scale flow rate [L/h]	Resolution [L/h]	Full scale flow rate [L/h]	Resolution [L/h]
3.000 to 2.005	0.005	---	---	30.00 to 20.05	0.05
2.000 to 1.002	0.002	12.00 to 10.02	0.02	20.00 to 10.02	0.02
1.000 to 0.300	0.001	10.00 to 1.20	0.01	10.00 to 3.00	0.01

F4H0002		F4H0005		F4H0020	
Full scale flow rate [m ³ /h]	Resolution [m ³ /h]	Full scale flow rate [m ³ /h]	Resolution [m ³ /h]	Full scale flow rate [m ³ /h]	Resolution [m ³ /h]
---	---	0.3000 to 0.2005	0.0005	---	---
0.1200 to 0.1002	0.0002	0.2000 to 0.1002	0.0002	1.200 to 1.002	0.002
0.1000 to 0.0120	0.0001	0.1000 to 0.0300	0.0001	1.000 to 0.120	0.001

● When the gas type is "4: Carbon dioxide (CO₂)"

Normal resolution: "Display resolution" (ζ - 4²) is set to 0 (Normal resolution)

F4H9050		F4H9200		F4H9500	
Full scale flow rate [L/h]	Resolution [L/h]	Full scale flow rate [L/h]	Resolution [L/h]	Full scale flow rate [L/h]	Resolution [L/h]
---	---	7.200 to 6.050	0.050	---	---
---	---	6.000 to 3.020	0.020	---	---
1.800 to 1.210	0.010	3.000 to 1.210	0.010	18.00 to 12.10	0.10
1.200 to 0.605	0.005	1.200 to 0.720	0.005	12.00 to 6.05	0.05
0.600 to 0.302	0.002	---	---	6.00 to 3.02	0.02
0.300 to 0.180	0.001	---	---	3.00 to 1.80	0.01

F4H0002		F4H0005		F4H0020	
Full scale flow rate [m ³ /h]	Resolution [m ³ /h]	Full scale flow rate [m ³ /h]	Resolution [m ³ /h]	Full scale flow rate [m ³ /h]	Resolution [m ³ /h]
0.07200 to 0.06050	0.00050	---	---	0.7200 to 0.6050	0.0050
0.06000 to 0.03020	0.00020	---	---	0.6000 to 0.3020	0.0020
0.03000 to 0.01210	0.00010	0.1800 to 0.1210	0.0010	0.3000 to 0.1210	0.0010
0.01200 to 0.00720	0.00005	0.1200 to 0.0605	0.0005	0.1200 to 0.0720	0.0005
---	---	0.0600 to 0.0302	0.0002	---	---
---	---	0.0300 to 0.0180	0.0001	---	---

High resolution: "Display resolution" (ζ - 4²) is set to 1 (High resolution)

F4H9050		F4H9200		F4H9500	
Full scale flow rate [L/h]	Resolution [L/h]	Full scale flow rate [L/h]	Resolution [L/h]	Full scale flow rate [L/h]	Resolution [L/h]
---	---	7.200 to 2.005	0.005	---	---
1.800 to 1.002	0.002	2.000 to 1.002	0.002	18.00 to 10.02	0.02
1.000 to 0.180	0.001	1.000 to 0.720	0.001	10.00 to 1.80	0.01

F4H0002		F4H0005		F4H0020	
Full scale flow rate [m ³ /h]	Resolution [m ³ /h]	Full scale flow rate [m ³ /h]	Resolution [m ³ /h]	Full scale flow rate [m ³ /h]	Resolution [m ³ /h]
0.07200 to 0.02005	0.00005	---	---	0.7200 to 0.2005	0.0005
0.02000 to 0.01002	0.00002	0.1800 to 0.1002	0.0002	0.2000 to 0.1002	0.0002
0.01000 to 0.00720	0.00001	0.1000 to 0.0180	0.0001	0.1000 to 0.0720	0.0001

● When the gas type is "9: Hydrogen (H₂)"

Normal resolution: "Display resolution" (㉔ - ㉔) is set to 0 (Normal resolution)

F4H9050		F4H9200		F4H9500	
Full scale flow rate [L/h]	Resolution [L/h]	Full scale flow rate [L/h]	Resolution [L/h]	Full scale flow rate [L/h]	Resolution [L/h]
---	---	48.00 to 30.20	0.20	---	---
---	---	30.20 to 12.10	0.10	---	---
12.00 to 6.05	0.05	12.00 to 6.05	0.05	120.0 to 60.5	0.5
6.00 to 3.02	0.02	6.00 to 4.80	0.02	60.0 to 30.2	0.2
3.00 to 1.20	0.01	---	---	30.0 to 12.0	0.1

F4H0002		F4H0005		F4H0020	
Full scale flow rate [m ³ /h]	Resolution [m ³ /h]	Full scale flow rate [m ³ /h]	Resolution [m ³ /h]	Full scale flow rate [m ³ /h]	Resolution [m ³ /h]
0.4800 to 0.3020	0.0020	---	---	3.600 to 3.020	0.020
0.3000 to 0.1210	0.0010	---	---	3.000 to 1.210	0.010
0.1200 to 0.0605	0.0005	1.200 to 0.605	0.005	1.200 to 0.605	0.005
0.0600 to 0.0480	0.0002	0.600 to 0.302	0.002	0.600 to 0.360	0.002
---	---	0.300 to 0.120	0.001	---	---

High resolution: "Display resolution" (㉔ - ㉔) is set to 1 (High resolution)

F4H9050		F4H9200		F4H9500	
Full scale flow rate [L/h]	Resolution [L/h]	Full scale flow rate [L/h]	Resolution [L/h]	Full scale flow rate [L/h]	Resolution [L/h]
---	---	48.00 to 20.05	0.05	---	---
12.00 to 10.02	0.02	20.00 to 10.02	0.02	120.0 to 100.2	0.2
10.00 to 1.20	0.01	10.00 to 4.80	0.01	100.0 to 12.0	0.1

F4H0002		F4H0005		F4H0020	
Full scale flow rate [m ³ /h]	Resolution [m ³ /h]	Full scale flow rate [m ³ /h]	Resolution [m ³ /h]	Full scale flow rate [m ³ /h]	Resolution [m ³ /h]
0.4800 to 0.2005	0.0005	---	---	3.600 to 2.005	0.005
0.2000 to 0.1002	0.0002	1.200 to 1.002	0.002	2.000 to 1.002	0.002
0.1000 to 0.0480	0.0001	1.000 to 0.120	0.001	1.000 to 0.360	0.001

● When the gas type is "10: Helium (He)"

Normal resolution: "Display resolution" ($\zeta - \psi_2$) is set to 0 (Normal resolution)

F4H9050		F4H9200		F4H9500	
Full scale flow rate [L/h]	Resolution [L/h]	Full scale flow rate [L/h]	Resolution [L/h]	Full scale flow rate [L/h]	Resolution [L/h]
7.200 to 6.050	0.050	---	---	72.00 to 60.50	0.50
6.000 to 3.020	0.020	48.00 to 30.20	0.20	60.00 to 30.20	0.20
3.000 to 1.210	0.010	30.00 to 12.10	0.10	30.00 to 12.10	0.10
1.200 to 0.720	0.005	12.00 to 6.05	0.05	12.00 to 7.20	0.05
---	---	6.00 to 4.80	0.02	---	---

F4H0002		F4H0005		F4H0020	
Full scale flow rate [m ³ /h]	Resolution [m ³ /h]	Full scale flow rate [m ³ /h]	Resolution [m ³ /h]	Full scale flow rate [m ³ /h]	Resolution [m ³ /h]
---	---	0.7200 to 0.6050	0.0050	---	---
0.4800 to 0.3020	0.0020	0.6000 to 0.3020	0.0020	3.000 to 1.210	0.010
0.3000 to 0.1210	0.0010	0.3000 to 0.1210	0.0010	1.200 to 0.605	0.005
0.1200 to 0.0605	0.0005	0.1200 to 0.0720	0.0005	0.600 to 0.302	0.002
0.0600 to 0.0480	0.0002	---	---	0.300	0.001

High resolution: "Display resolution" ($\zeta - \psi_2$) is set to 1 (High resolution)

F4H9050		F4H9200		F4H9500	
Full scale flow rate [L/h]	Resolution [L/h]	Full scale flow rate [L/h]	Resolution [L/h]	Full scale flow rate [L/h]	Resolution [L/h]
7.200 to 2.005	0.005	48.00 to 20.05	0.05	72.00 to 20.05	0.05
2.000 to 1.002	0.002	20.00 to 10.02	0.02	20.00 to 10.02	0.02
1.000 to 0.720	0.001	10.00 to 4.80	0.01	10.00 to 7.20	0.01

F4H0002		F4H0005		F4H0020	
Full scale flow rate [m ³ /h]	Resolution [m ³ /h]	Full scale flow rate [m ³ /h]	Resolution [m ³ /h]	Full scale flow rate [m ³ /h]	Resolution [m ³ /h]
0.4800 to 0.2005	0.0005	0.7200 to 0.2005	0.0005	3.000 to 2.005	0.005
0.2000 to 0.1002	0.0002	0.2000 to 0.1002	0.0002	2.000 to 1.002	0.002
0.1000 to 0.0480	0.0001	0.1000 to 0.0720	0.0001	1.000 to 0.300	0.001

● **Unit of flow rate: g/min or mg/min**

● **When the gas type is "1: Air/nitrogen (N₂)"***

Normal resolution: "Display resolution" (㉔ - ㉔㉔) is set to 0 (Normal resolution)

F4H9050		F4H9200		F4H9500	
Full scale flow rate [mg/min]	Resolution [mg/min]	Full scale flow rate [mg/min]	Resolution [mg/min]	Full scale flow rate [mg/min]	Resolution [mg/min]
62.50 to 60.50	0.50	250.0 to 121.0	1.0	625.0 to 605.0	5.0
60.00 to 30.20	0.20	120.0 to 60.5	0.5	600.0 to 302.0	2.0
30.00 to 12.10	0.10	60.0 to 30.2	0.2	300.0 to 121.0	1.0
12.00 to 6.25	0.05	30.0 to 25.0	0.1	120.0 to 62.5	0.5

F4H0002		F4H0005		F4H0020	
Full scale flow rate [g/min]	Resolution [g/min]	Full scale flow rate [g/min]	Resolution [g/min]	Full scale flow rate [g/min]	Resolution [g/min]
2.500 to 1.210	0.010	6.250 to 6.050	0.050	25.00 to 12.10	0.10
1.200 to 0.605	0.005	6.000 to 3.020	0.020	12.00 to 6.05	0.05
0.600 to 0.302	0.002	3.000 to 1.210	0.010	6.00 to 3.02	0.02
0.300 to 0.250	0.001	1.200 to 0.625	0.005	3.00 to 2.50	0.01

High resolution: "Display resolution" (㉔ - ㉔㉔) is set to 1 (High resolution)

F4H9050		F4H9200		F4H9500	
Full scale flow rate [mg/min]	Resolution [mg/min]	Full scale flow rate [mg/min]	Resolution [mg/min]	Full scale flow rate [mg/min]	Resolution [mg/min]
62.50 to 20.05	0.05	250.0 to 200.5	0.5	625.0 to 200.5	0.5
20.00 to 10.02	0.02	200.0 to 100.2	0.2	200.0 to 100.2	0.2
10.00 to 6.25	0.01	100.0 to 25.0	0.1	100.0 to 62.5	0.1

F4H0002		F4H0005		F4H0020	
Full scale flow rate [g/min]	Resolution [g/min]	Full scale flow rate [g/min]	Resolution [g/min]	Full scale flow rate [g/min]	Resolution [g/min]
2.500 to 2.005	0.005	6.250 to 2.005	0.005	25.00 to 20.05	0.05
2.000 to 1.002	0.002	2.000 to 1.002	0.002	20.00 to 10.02	0.02
1.000 to 0.250	0.001	1.000 to 0.625	0.001	10.00 to 2.50	0.01

* When "Gas type" (㉔ - ㉔) is set to "1: Air/nitrogen" and "Flow rate display unit" (㉔ - ㉔) is set to "2: g/min or mg/min," conversion is based on the density of nitrogen (1.2500).

To convert based on the density of air, set "Gas type" (㉔ - ㉔) to "0: CF for the gas type is set by the user" and set "Density for unit conversion (for user-set units) (㉔ - ㉔)" to the density of air (1.2930). In addition, use "Conversion factor set by user" (㉔ - ㉔) with the initial value (1.000) unchanged.

● When the gas type is "2: Oxygen (O₂)"

Normal resolution: "Display resolution" (ζ - 4ζ) is set to 0 (Normal resolution)

F4H9050		F4H9200		F4H9500	
Full scale flow rate [mg/min]	Resolution [mg/min]	Full scale flow rate [mg/min]	Resolution [mg/min]	Full scale flow rate [mg/min]	Resolution [mg/min]
71.45 to 60.50	0.50	286.0 to 121.0	1.0	714.5 to 605.0	5.0
60.00 to 30.20	0.20	120.0 to 60.5	0.5	600.0 to 302.0	2.0
30.00 to 12.10	0.10	60.0 to 30.2	0.2	300.0 to 121.0	1.0
12.00 to 7.15	0.05	30.0 to 28.6	0.1	120.0 to 71.5	0.5

F4H0002		F4H0005		F4H0020	
Full scale flow rate [g/min]	Resolution [g/min]	Full scale flow rate [g/min]	Resolution [g/min]	Full scale flow rate [g/min]	Resolution [g/min]
2.860 to 1.210	0.010	7.145 to 6.050	0.050	28.60 to 12.10	0.10
1.200 to 0.605	0.005	6.000 to 3.020	0.020	12.00 to 6.05	0.05
0.600 to 0.302	0.002	3.000 to 1.210	0.010	6.00 to 3.02	0.02
0.300 to 0.286	0.001	1.200 to 0.715	0.005	3.00 to 2.86	0.01

High resolution: "Display resolution" (ζ - 4ζ) is set to 1 (High resolution)

F4H9050		F4H9200		F4H9500	
Full scale flow rate [mg/min]	Resolution [mg/min]	Full scale flow rate [mg/min]	Resolution [mg/min]	Full scale flow rate [mg/min]	Resolution [mg/min]
71.45 to 20.05	0.05	286.0 to 200.5	0.5	714.5 to 200.5	0.5
20.00 to 10.02	0.02	200.0 to 100.2	0.2	200.0 to 100.2	0.2
10.00 to 7.15	0.01	100.0 to 28.6	0.1	100.0 to 71.5	0.1

F4H0002		F4H0005		F4H0020	
Full scale flow rate [g/min]	Resolution [g/min]	Full scale flow rate [g/min]	Resolution [g/min]	Full scale flow rate [g/min]	Resolution [g/min]
2.860 to 2.005	0.005	7.145 to 2.005	0.005	28.60 to 20.05	0.05
2.000 to 1.002	0.002	2.000 to 1.002	0.002	20.00 to 10.02	0.02
1.000 to 0.286	0.001	1.000 to 0.715	0.001	10.00 to 2.86	0.01

● When the gas type is "3: Argon (Ar)"

Normal resolution: "Display resolution" ($\zeta - \psi_2$) is set to 0 (Normal resolution)

F4H9050		F4H9200		F4H9500	
Full scale flow rate [mg/min]	Resolution [mg/min]	Full scale flow rate [mg/min]	Resolution [mg/min]	Full scale flow rate [mg/min]	Resolution [mg/min]
89.00 to 60.50	0.5	357.0 to 302.0	2.0	892.0 to 605.0	5.0
60.00 to 30.20	0.2	300.0 to 121.0	1.0	600.0 to 302.0	2.0
30.00 to 12.10	0.1	120.0 to 60.5	0.5	300.0 to 121.0	1.0
12.00 to 8.90	0.05	60.0 to 35.6	0.2	120.0 to 89.0	0.5

F4H0002		F4H0005		F4H0020	
Full scale flow rate [g/min]	Resolution [g/min]	Full scale flow rate [g/min]	Resolution [g/min]	Full scale flow rate [g/min]	Resolution [g/min]
3.570 to 3.020	0.020	8.920 to 6.050	0.050	35.70 to 30.20	0.20
3.000 to 1.210	0.010	6.000 to 3.020	0.020	30.00 to 12.10	0.10
1.200 to 0.605	0.005	3.000 to 1.210	0.010	12.00 to 6.05	0.05
0.600 to 0.356	0.002	1.200 to 0.892	0.005	6.00 to 3.56	0.02

High resolution: "Display resolution" ($\zeta - \psi_2$) is set to 1 (High resolution)

F4H9050		F4H9200		F4H9500	
Full scale flow rate [mg/min]	Resolution [mg/min]	Full scale flow rate [mg/min]	Resolution [mg/min]	Full scale flow rate [mg/min]	Resolution [mg/min]
89.20 to 80.10	0.1	---	---	892.0 to 801.0	1.0
80.00 to 20.05	0.05	357.0 to 200.5	0.5	800.0 to 200.5	0.5
20.00 to 10.02	0.02	200.0 to 100.2	0.2	200.0 to 100.2	0.2
10.00 to 8.92	0.01	100.0 to 35.7	0.1	100.0 to 89.2	0.1

F4H0002		F4H0005		F4H0020	
Full scale flow rate [g/min]	Resolution [g/min]	Full scale flow rate [g/min]	Resolution [g/min]	Full scale flow rate [g/min]	Resolution [g/min]
---	---	8.920 to 8.010	0.01	---	---
3.570 to 2.005	0.005	8.000 to 2.005	0.005	35.70 to 20.05	0.05
2.000 to 1.002	0.002	2.000 to 1.002	0.002	20.00 to 10.02	0.02
1.000 to 0.357	0.001	1.000 to 0.892	0.001	10.00 to 3.57	0.01

● When the gas type is "4: Carbon dioxide (CO₂)"

Normal resolution: "Display resolution" (└ - 4┘) is set to 0 (Normal resolution)

F4H9050		F4H9200		F4H9500	
Full scale flow rate [mg/min]	Resolution [mg/min]	Full scale flow rate [mg/min]	Resolution [mg/min]	Full scale flow rate [mg/min]	Resolution [mg/min]
59.40 to 30.20	0.20	237.0 to 121.0	1.0	594.0 to 302.0	2.0
30.00 to 12.10	0.10	120.0 to 60.5	0.5	300.0 to 121.0	1.0
12.00 to 6.05	0.05	60.0 to 30.2	0.2	120.0 to 60.5	0.5
6.00 to 5.94	0.02	30.0 to 23.7	0.1	60.0 to 59.4	0.2

F4H0002		F4H0005		F4H0020	
Full scale flow rate [g/min]	Resolution [g/min]	Full scale flow rate [g/min]	Resolution [g/min]	Full scale flow rate [g/min]	Resolution [g/min]
---	---	5.940 to 3.020	0.020	---	---
2.370 to 1.210	0.010	3.000 to 1.210	0.010	23.70 to 12.10	0.10
1.200 to 0.240	0.005	1.200 to 0.595	0.005	12.00 to 2.40	0.05

High resolution: "Display resolution" (└ - 4┘) is set to 1 (High resolution)

F4H9050		F4H9200		F4H9500	
Full scale flow rate [mg/min]	Resolution [mg/min]	Full scale flow rate [mg/min]	Resolution [mg/min]	Full scale flow rate [mg/min]	Resolution [mg/min]
59.30 to 20.05	0.05	237.0 to 200.5	0.5	593.0 to 200.5	0.5
20.00 to 10.02	0.02	200.0 to 100.2	0.2	200.0 to 100.2	0.2
10.00 to 5.93	0.01	100.0 to 23.7	0.1	100.0 to 59.3	0.1

F4H0002		F4H0005		F4H0020	
Full scale flow rate [g/min]	Resolution [g/min]	Full scale flow rate [g/min]	Resolution [g/min]	Full scale flow rate [g/min]	Resolution [g/min]
2.370 to 2.005	0.005	5.930 to 2.005	0.005	23.70 to 20.05	0.05
2.000 to 1.002	0.002	2.000 to 1.002	0.002	20.00 to 10.02	0.02
1.000 to 0.237	0.001	1.000 to 0.593	0.001	10.00 to 2.37	0.01

● When the gas type is "9: Hydrogen (H₂)"

Normal resolution: "Display resolution" (ζ - ζ₂) is set to 0 (Normal resolution)

F4H9050		F4H9200		F4H9500	
Full scale flow rate [mg/min]	Resolution [mg/min]	Full scale flow rate [mg/min]	Resolution [mg/min]	Full scale flow rate [mg/min]	Resolution [mg/min]
---	---	72.00 to 60.50	0.50	---	---
18.00 to 12.10	0.10	60.00 to 30.20	0.20	180.0 to 121.0	1.0
12.00 to 6.05	0.05	30.00 to 12.10	0.10	120.0 to 60.5	0.5
6.00 to 3.02	0.02	12.00 to 7.20	0.05	60.0 to 30.2	0.2
3.00 to 1.80	0.01	---	---	30.0 to 18.0	0.1

F4H0002		F4H0005		F4H0020	
Full scale flow rate [g/min]	Resolution [g/min]	Full scale flow rate [g/min]	Resolution [g/min]	Full scale flow rate [g/min]	Resolution [g/min]
0.7150 to 0.6050	0.0050	---	---	5.400 to 3.020	0.020
0.6000 to 0.3020	0.0020	1.800 to 1.210	0.010	3.000 to 1.210	0.010
0.3000 to 0.1210	0.0010	1.200 to 0.605	0.005	1.200 to 0.605	0.005
0.1200 to 0.0715	0.0005	0.600 to 0.302	0.002	0.600 to 0.540	0.002
---	---	0.300 to 0.180	0.001	---	---

High resolution: "Display resolution" (ζ - ζ₂) is set to 1 (High resolution)

F4H9050		F4H9200		F4H9500	
Full scale flow rate [mg/min]	Resolution [mg/min]	Full scale flow rate [mg/min]	Resolution [mg/min]	Full scale flow rate [mg/min]	Resolution [mg/min]
---	---	71.90 to 20.05	0.05	---	---
18.00 to 10.02	0.02	20.00 to 10.02	0.02	180.0 to 100.2	0.2
10.00 to 1.80	0.01	10.00 to 7.19	0.01	100.0 to 18.0	0.1

F4H0002		F4H0005		F4H0020	
Full scale flow rate [g/min]	Resolution [g/min]	Full scale flow rate [g/min]	Resolution [g/min]	Full scale flow rate [g/min]	Resolution [g/min]
0.7190 to 0.2005	0.0005	---	---	5.395 to 2.005	0.005
0.2000 to 0.1002	0.0002	1.798 to 1.002	0.002	2.000 to 1.002	0.002
0.1000 to 0.0719	0.0001	1.000 to 0.180	0.001	1.000 to 0.539	0.001

● When the gas type is "10: Helium (He)"

Normal resolution: "Display resolution" (㉟ - ㉟) is set to 0 (Normal resolution)

F4H9050		F4H9200		F4H9500	
Full scale flow rate [mg/min]	Resolution [mg/min]	Full scale flow rate [mg/min]	Resolution [mg/min]	Full scale flow rate [mg/min]	Resolution [mg/min]
21.40 to 12.10	0.10	143.0 to 121.0	1.0	214.0 to 121.0	1.0
12.00 to 6.05	0.05	120.0 to 60.5	0.5	120.0 to 60.5	0.5
6.00 to 3.02	0.02	60.0 to 30.2	0.2	60.0 to 30.2	0.2
3.00 to 2.14	0.01	30.0 to 14.3	0.1	30.0 to 21.4	0.1

F4H0002		F4H0005		F4H0020	
Full scale flow rate [g/min]	Resolution [g/min]	Full scale flow rate [g/min]	Resolution [g/min]	Full scale flow rate [g/min]	Resolution [g/min]
---	---	---	---	8.950 to 6.050	0.050
1.430 to 1.210	0.010	2.140 to 1.210	0.010	6.000 to 3.020	0.010
1.200 to 0.605	0.005	1.200 to 0.605	0.005	3.000 to 1.205	0.005
0.600 to 0.302	0.002	0.600 to 0.302	0.002	1.200 to 0.892	0.002
0.300 to 0.143	0.001	0.300 to 0.214	0.001	---	---

High resolution: "Display resolution" (㉟ - ㉟) is set to 1 (High resolution)

F4H9050		F4H9200		F4H9500	
Full scale flow rate [mg/min]	Resolution [mg/min]	Full scale flow rate [mg/min]	Resolution [mg/min]	Full scale flow rate [mg/min]	Resolution [mg/min]
21.40 to 20.05	0.05	---	---	214.0 to 200.5	0.5
20.00 to 10.02	0.02	142.8 to 100.2	0.2	200.0 to 100.2	0.2
10.00 to 2.14	0.01	100.0 to 14.3	0.1	100.0 to 21.4	0.1

F4H0002		F4H0005		F4H0020	
Full scale flow rate [g/min]	Resolution [g/min]	Full scale flow rate [g/min]	Resolution [g/min]	Full scale flow rate [g/min]	Resolution [g/min]
---	---	---	---	8.930 to 8.010	0.010
---	---	2.140 to 2.005	0.005	8.000 to 2.005	0.005
1.428 to 1.002	0.002	20.000 to 1.002	0.002	2.000 to 1.002	0.002
1.000 to 0.143	0.001	1.000 to 0.214	0.001	1.000 to 0.893	0.001

■ Functions related to maintenance

The functions below are available for maintenance. The following data can be read out or the setting can be made through RS-485 communication or through PC loader-dedicated communication.

Note

-  F4H Series Compact Digital Mass Flow Controller User's Manual for RS-485 for Communication Functions (CP-SP-1408E) or the manual for MLP300A000 PC Loader Software .

● Number of times the valve is ON

It is possible to read out the number of times the valve is ON through communication.

Handling Precautions

- Because recording takes place every 10 minutes, depending on when the power of the device is shut off, there may be cases where the record for a period as long as 10 minutes before shut-down is not kept.

Communication addresses: 9501W (last 4 digits of the number of times the valve is ON), and
9502W (first 4 digits of the number of times the valve is ON)

● Records of the occurrence of as many as five alarms and events that can be read out through communication are recorded

If more than five alarms or events have occurred, the latest 5 records are saved and the older ones are deleted.

Communication addresses: 9511W to 9526W

● Forced analog output, forced valve drive current output

When the "forced test" flag is set through communication, the analog output and the drive current for valve control can be kept at a steady value. The forced analog output is used to test the connection with the receiving device.

The forced valve drive current output is used to check whether there are any disturbances (such as pulsation) which affect control.

Item	Data range	RAM
		Address Decimal (hexadecimal)
Forced test flag	Bit 0: Forced AO 1: On 0: Off Bit 1: Forced valve drive current output 1: On 0: Off	9991 (2707)
Forced AO level	0.0 to 100.0 %	9992 (2708)
Forced valve drive current output level	0.0 to 100.0 %	9993 (2709)

Note: If the forced test flag is enabled, normal operation cannot be performed.
Turn off the main unit power or set the forced test flag bits to 0 ("Off").

Chapter 6. TROUBLESHOOTING

■ Operation at alarm/event occurrence

When an instantaneous flow rate deviation alarm occurs or an alarm occurs during controller self-diagnosis, the device forcibly switches to the operation mode currently selected for the "Operation at alarm/event occurrence" function setting (ξ - ιδ).

The color and behavior of the NET and PWR indicators vary depending on the type of alarm or event.

Note

-  Chapter 4. BASIC SETTING LED indication (P. 4-4)

The following shows the behavior of the device as determined by the "Operation at alarm/event occurrence" function setting (ξ - ιδ).

ξ - ιδ setting	When an alarm occurs			When an event occurs		
	Control mode	Digital output	PWR LED	Control mode	Digital output	NET LED
0	Control continues	OFF	Red LED is lit	Control continues	OFF	Orange LED blinks slowly
1	Control continues	ON	Red LED is lit	Control continues	ON	Orange LED blinks slowly
2	Forced fully closed	ON	Red LED is lit	Forced fully closed	ON	Orange LED blinks slowly
3	Forced fully open	ON	Red LED is lit	Forced fully open	ON	Orange LED blinks slowly
4*	Control continues	ON	Red LED is lit	Control continues	OFF	Orange LED blinks slowly
5	Forced fully closed	ON	Red LED is lit	Forced fully closed	OFF	Orange LED blinks slowly
6	Forced fully open	ON	Red LED is lit	Forced fully open	OFF	Orange LED blinks slowly
7*	Control continues	ON	Red LED is lit	Control continues	OFF	Orange LED blinks slowly
8	Forced fully closed	ON	Red LED is lit	Control continues	OFF	Orange LED blinks slowly
9	Forced fully open	ON	Red LED is lit	Control continues	OFF	Orange LED blinks slowly

* The behavior of settings 4 and 7 is identical.

● Classes of alarms and events

Class	Code	Description	Cause	Remedy
Event	<i>RL01</i>	Flow rate deviation lower limit event	Insufficient alarm/event judgment delay time, insufficient voltage, insufficient inlet pressure, excessive inlet pressure, excessive operating temperature, etc.	Request repair service if there are no problems related to the items listed to the left.
Event	<i>RL02</i>	Flow rate deviation upper limit event	Insufficient alarm/event judgment delay time, valve problem, sensor problem, etc.	Request repair service if there are no problems related to the delay time.
Event	<i>RL11</i>	Valve drive current lower limit event	Insufficient alarm/event judgment delay time, alarm current setting is too high, excessive inlet pressure, etc.	Change the settings.
Event	<i>RL12</i>	Valve drive current upper limit event	Insufficient alarm/event judgment delay time, alarm current setting is too low, insufficient voltage, insufficient inlet pressure, etc.	Change the settings.
Event	<i>RL51</i>	Multipoint flow rate correction setting error	An incorrect correction value was entered.	Change the settings.
Alarm	<i>RL51</i>	Sensor unit error (setting error)	Correction according to the piping orientation setting (④ - ④) cannot be executed properly because of a built-in electronic board error due to a failure or disconnection.	Request repair service if turning the power off and back on does not restore normal device operation.
Alarm	<i>RL52</i>	Sensor unit error (PV error)	The correct instantaneous flow rate (PV) cannot be obtained because of a built-in electronic board error due to a failure or disconnection.	Request repair service if turning the power off and back on does not restore normal device operation.
Event	<i>RL71</i>	Valve overheating prevention limit activated	During the control or fully open mode, the gas is forcibly shut off for five minutes or longer by an external device.	When the gas is shut off by an external device and remains off, change the set flow rate to zero or put the valve in fully closed mode.

Class	Code	Description	Cause	Remedy
Event	<i>RL72</i>	Valve overheating prevention limit activated (2)	During the control or fully open mode, the gas is forcibly shut off for 30 minutes or longer by an external device.	When the gas is shut off by an external device and remains off, change the set flow rate to zero or put the valve in fully closed mode.
Alarm	<i>RL8100</i>	Sensor error 0 (Heater voltage Va lower limit error)	Sensor failure, foreign object on sensor, condensation on sensor, etc.	Remove the probable causes. If normal device operation does not resume after the power has been shut off for a while, request repair.
Alarm	<i>RL8101</i>	Sensor error 1 (Heater voltage Va upper limit error)		
Alarm	<i>RL8102</i>	Sensor error 2 (Heater voltage Vb lower limit error)		
Alarm	<i>RL8103</i>	Sensor error 3 (Heater voltage Vb upper limit error)		
Alarm	<i>RL8204</i>	Sensor error 4 (Measured flow rate signal lower limit error)	Excessively large flow rate when the valve is fully open, reverse flow, sensor failure, foreign object on sensor, etc.	Remove the probable causes. If normal device operation does not resume after the power has been shut off for a while, request repair.
Alarm	<i>RL8205</i>	Sensor error 5 (Measured flow rate signal upper limit error)		
Alarm	<i>RL910</i>	Sensor calibration data error	Data corrupted due to electrical noise.	Request repair services if resetting the power supply does not cause normal device operations to be restored.
Alarm	<i>RL911</i>	Error in factory adjustment data	Data corrupted due to electrical noise.	Request repair service if turning the power off and back on does not restore normal device operation.
Alarm	<i>RL920</i>	Error in factory setting for sensor	Data corrupted due to electrical noise.	Request repair service if turning the power off and back on does not restore normal device operation.
Alarm	<i>RL921</i>	Error in parameter function setting	Power was shut off while a setting was being written to memory.	Change any function setting and try to save the setting.
Alarm	<i>RL931</i>	Error in function setting	Power was shut off while a setting was being written to memory.	Change any function setting and try to save the setting.

■ Other problems

Symptom	Cause	Remedy
Flow rate is zero but flow rate output does not read zero.	<ul style="list-style-type: none"> • The device is mounted vertically. • Condensation on the sensor. • Drift in the zero point of the sensor. • Foreign object on the sensor. 	<ul style="list-style-type: none"> • Specify the mounting orientation for the "Piping orientation" function setting ($\zeta - 34$) and set the actual pressure for parameter code $P - 23$, "Primary pressure setting." Alternatively, use the "Low flow cutoff function" ($\zeta - 29$). • Insert a mist trap upstream. • Do the zero flow adjustment described below. • Request repair.
Flow rate does not stabilize.	<ul style="list-style-type: none"> • Operating differential pressure is excessive. • Large inlet pressure fluctuation. • Pressure regulator interference. • Large pressure loss in piping (large fluctuation in operating differential pressure according to the flow rate) • Check valve vibration. • Operating differential pressure (function setting $\zeta - 35$) does not match the differential pressure actually used. 	<ul style="list-style-type: none"> • Reduce the inlet pressure. • Insert a pressure regulator upstream. • Change the regulator pressure setting or increase the piping capacity between the device and regulator. • Use the PV filter ($\zeta - 23$). • Use a larger diameter pipe. • Remove equipment causing a large pressure loss or insert a control between this device and the equipment. • Change the check valve to one with a low cracking pressure. • Adjust the operating differential pressure setting to the actual operating differential pressure or set the operating differential pressure to "2."
Poor accuracy	<ul style="list-style-type: none"> • Temperature standard does not match that of the reference flowmeter. • Regulator is vibrating slightly. • Foreign object on the sensor. 	<ul style="list-style-type: none"> • Adjust the temperature standard. It can be changed in "Flow rate standard condition" ($\zeta - 49$). • Change the regulator pressure setting. • Request repair.

● Adjustment of zero flow

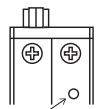

Zero point adjustment switch

If the reason that the actual flow rate is zero but the flow rate display does not read zero could be because of drift in the zero point of the sensor, adjust the zero point as shown below. When F4H valve is closed, the sensor signal currently detected can be recorded as zero.

Operation

- (1) Press for 5 s to activate the zero-point correction.
- (2) Press for 20 s to return to the factory-set value.

● Canceling an alarm

When "Alarm/event response," function code $\xi - 15$, is set to 2, 3, 5, or 6, and an alarm or event occurs (an alarm only in the case of 5 and 6), the operation mode (forced fully open or forced fully closed) continues until the alarm is canceled.

To cancel the alarm, switch the operation mode to "Control mode" through communication, or use the rotary switch.

● Canceling the alarm using rotary switch RSW1

- (1) Change the current value set with rotary switch RSW1. At this point, the alarm is not canceled.
- (2) Change the rotary switch back to the original setting. At this point, the alarm is canceled.

Memo

Chapter 7. SPECIFICATIONS

■ F4H9050/9200/9500/0002/0005/0020

Item		F4H9050	F4H9200	F4H9500	F4H0002	F4H0005	F4H0020
Valve	Valve type	Proportional solenoid valve					
	Valve operation	Normally closed when not powered (N.C.)					
	Durability	A minimum of 1,000,000 full-open-to-full-close cycles with solenoid mounted vertically or horizontally					
Full scale flow rate*1		50.00 mL/min	200.0 mL/min	500.0 mL/min	2.000 L/min	5.000 L/min	20.00 L/min
Gas type		<p>Air and nitrogen model: Air/nitrogen (N₂), argon (Ar), carbon dioxide (CO₂), hydrogen (H₂), helium (He). Factory setting: air/nitrogen, selectable by setting.</p> <p>Oxygen model: Oxygen (O₂), air/nitrogen (N₂), argon (Ar), carbon dioxide (CO₂), hydrogen (H₂), helium (He). Factory setting: oxygen, selectable by setting.</p> <p>Gas must be dry and not contain corrosive components (chlorine, sulfur, acid, etc.). It must also be clean and not contain any dust or oil mist.</p>					
Control	Control range	2 to 100 % FS		1 to 100 % FS			
		The control range depends on the gas type. See the "Gas type and control range" table in *1 (p. 7-3) .					
	Valve output update cycle	1 ms					
	Responsiveness (at standard differential pressure)	Time required to go from a flow rate of 0 to a stable flow at the set amount ± 2 % FS: 0.3 s (typ.)					
	Accuracy *2	± 2 % FS		± 1 % FS			
	Repeatability	± 0.2 % FS ± 1 digit					
	Reproducibility	0.5 % FS + 1 digit					
PV offset from set point	± 0.1 % FS ± 1 digit						
Pressure	Standard differential pressure*3	100 kPa		200 kPa			
	Operating differential pressure range 1*4 at ambient temperature -10 ≤ t ≤ 40 °C	20 to 200 kPa	50 to 300 kPa	100 to 300 kPa	50 to 300 kPa	100 to 300 kPa*9	180 to 300 kPa*9,*10
	Operating differential pressure range 2*4 at ambient temperature 40 < t ≤ 50 °C	20 to 200 kPa	100 to 300 kPa	150 to 300 kPa*5	100 to 300 kPa	150 to 300 kPa*9	Not available
	Allowable inlet pressure*6	0.5 MPa (gauge) max.					
	Pressure resistance	1 MPa (gauge)					
Effect of pressure (per 100 kPa with controller mounted horizontally)	± 1.0 % FS max.	± 0.5 % FS max.	± 0.2 % FS max.	± 0.2 % FS max.	± 0.2 % FS max.	± 0.2 % FS max.	

Chapter 7. SPECIFICATIONS

Item		F4H9050	F4H9200	F4H9500	F4H0002	F4H0005	F4H0020
Temperature	Standard operating temperature *3	23 °C					
	Allowable operating temperature	-10 to +50 °C					-10 to +40 °C
	Allowable storage temperature	-20 to +70 °C					
	Effect of temperature	±0.1 % FS max. per 1 °C					
Humidity	Allowable operating humidity	10 to 90% RH (without condensation)					
External leakage	Helium leakage rate	1×10 ⁻⁸ Pa·m ³ /s (not including O-ring permeability)					
Flow rate setting	Method	External analog input, RS-485 communications (3-wire system), MLP loader communications *7					
	Setting resolution	External analog input: approx. 1:3000 RS-485 (3-wire system) or MLP loader communications: 1:1000 (High resolution)					
	External analog input	Input range: 0 to 5 V DC (factory setting) / 1 to 5 V DC / 4 to 20 mA Input impedance: 1 MΩ ± 10 % (with voltage input) / 250 Ω ± 10 % (with current input)					
Analog output	Output type	Instantaneous flow rate (PV) output					
	Output range	0 to 5 V DC (factory setting) / 1 to 5 V DC / 4 to 20 mA					
	Maximum output	110 % min. (120 % max.) (maximum output when the flow rate is out of range)					
	Accuracy	Indication accuracy ±0.3 % FS					
	External load resistance	250 kΩ min. (with voltage output) / 300Ω max. (with current output)					
	Output resolution	Approx. 1:3000					
External contacts	Number of input points	1					
Input	Circuit type	Non-voltage contacts or open collector					
	Terminal voltage with contacts OFF	4.5 ± 1 V					
	Terminal current with contacts ON	Approx. 0.5 mA					
	Allowable ON contact resistance	250 Ω max.					
	Allowable OFF contact resistance	100 kΩ min.					
	Allowable ON residual voltage	0.8 V max. (with open collector)					
	Allowable OFF leakage current	50 μA max. (with open collector)					
Event output	Number of outputs	1					
	Output rating	30 V DC, 30 mA max. (open collector non-isolated output)					
	Residual voltage when ON	1 V max.					
	Leakage current when OFF	0.5 μA max. (Vcc = 30 V, 25 °C)					

Item		F4H9050	F4H9200	F4H9500	F4H0002	F4H0005	F4H0020
Communication specifications	Communication system	RS-485 (CPL or Modbus-RTU)					
	Connection	RJ45 × 2 Loader communication: loader jack connector					
	Transmission speed	9600, 19200, 38400 bps (only 19200 bps for loader communications)					
Supply power	Rating	24 V DC, current consumption: 300 mA max.					
	Allowable voltage range	22.8 to 25.2 V DC (ripple: 5 % max.)					
	Isolation	Power circuit and I/O circuit are isolated.					
Main gas-contacting materials		SUS316, fluororesin, fluoroelastomer					
Connection method		9/16-18 UNF, Rc 1/4, 1/4 Swagelok or equivalent, 1/4 VCR or equivalent					
Mounting orientation		Horizontally (note that the top panel must not face downward), vertical not allowed	Horizontally (note that the top panel must not face downward) or vertically*8				
Mass		Approx. 700 g (excluding fittings)					
Standards and regulations compliance		EN 61326-1:2013, EN 61326-2-3:2013 During EMC testing, the reading or output may fluctuate by the equivalent of ±5 % FS.					

*1. mL/min and L/min indicate the volumetric flow rate per minute converted to conditions of 0 °C and 101.325 kPa (1 atm). The reference temperature can be changed to 20, 25, or 35 °C.

The controllable flow rate range varies depending on the type of gas. For details, see the following table.

Gas type and control range

Gas type	F4H9050	F4H9200	F4H9500	F4H0002	F4H0005	F4H0020
Air/nitrogen (N ₂)	1.00 to 50.00 [mL/min]	2.0 to 200.0 [mL/min]	5.0 to 500.0 [mL/min]	0.020 to 2.000 [L/min]	0.050 to 5.000 [L/min]	0.20 to 20.00 [L/min]
Oxygen (O ₂)	1.00 to 50.00 [mL/min]	2.0 to 200.0 [mL/min]	5.0 to 500.0 [mL/min]	0.020 to 2.000 [L/min]	0.050 to 5.000 [L/min]	0.20 to 20.00 [L/min]
Argon (Ar)	0.60 to 30.00 [mL/min]	1.2 to 120.0 [mL/min]	3.0 to 300.0 [mL/min]	0.012 to 1.200 [L/min]	0.030 to 3.000 [L/min]	0.12 to 12.00 [L/min]
Carbon dioxide (CO ₂)	4.0 to 200.0 [mL/min]	8.0 to 800.0 [mL/min]	20 to 2000 [mL/min]	0.080 to 8.000 [L/min]	0.20 to 20.00 [L/min]	0.80 to 60.00 [L/min]
Hydrogen (H ₂)	4.0 to 120.0 [mL/min]	8.0 to 800.0 [mL/min]	20 to 1200 [mL/min]	0.080 to 8.000 [L/min]	0.20 to 12.00 [L/min]	0.80 to 50.00 [L/min]

Note: When controlling the flow rate, use the gas within the range indicated in the table.

- *2 Instrument error under standard conditions according to our equipment.
Standard conditions
 - Fluid: air ● Fluid pressure: standard differential pressure $\pm 5\%$
 - Ambient temperature: $23 \pm 3\text{ }^\circ\text{C}$
 - Supply voltage: $24\text{ V DC} \pm 2\%$
 - Warm-up time: leave device at room temperature for more than 2 hours and wait at least 30 minutes after powering up
 - Vibration: 0 m/s^2 ● Mounting orientation: top panel must face upward.
 - Length of straight pipe: 50 mm or more for upstream straight pipe, 25 mm or more for downstream straight pipe
 - Piping: use our standard fittings (Rc/Swagelok or equivalent / VCR or equivalent). When an Rc fitting is used, the inside diameter of the straight pipe section must be greater than 4 mm.
 - Gas temperature: ambient air temperature $\pm 1\text{ }^\circ\text{C}$
 - Gas dew point temperature: $-18\text{ }^\circ\text{C}$ or below.
- *3 This is the temperature/pressure during calibration.
- *4 Operation is possible even below the required differential pressure, but the controllable flow rate range is narrower.
- *5 The supply voltage must be kept at 23.5 V DC or above.
- *6 For information on the advisability of using an inlet pressure greater than 0.5 MPa (gauge), contact Azbil Corporation.
- *7 To use loader communication, a USB loader cable and PC loader software (sold separately) are required.
- *8 Measurement error occurs if the device is vertically mounted. To avoid this, specify the mounting orientation for function code $\text{L} - 34$, the piping orientation, and set the actual pressure for parameter code $\text{P} - 23$, the primary pressure setting.
- *9 To be used with a supply voltage from 23.5 to 25.2 V.
- *10 The maximum operating differential pressure varies according to the supply voltage. See the graphs (for air) below.
The operating differential pressure range for argon (Ar) is 250 to 300 kPa.

■ **Applied voltage and maximum differential pressure (air) for F4H0020**

F4H0020 Applied voltage and maximum differential pressure (air)

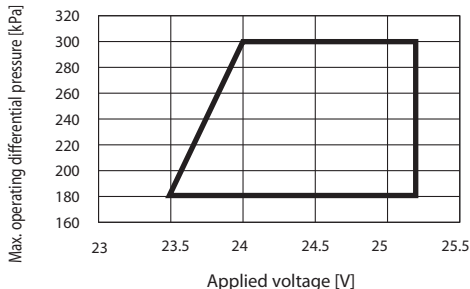

■ Korean KC mark

CP-SP-1405-1

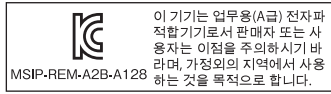

■ Relationship between differential pressure and flow rate when the valve is fully open (for air)

Note: The following is reference data from our in-house evaluation.

● F4H9050/9200/9500

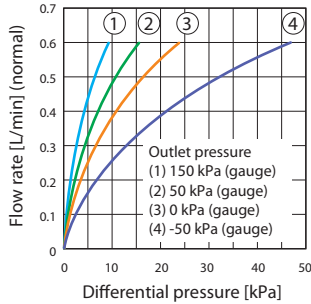

● F4H0002/0005

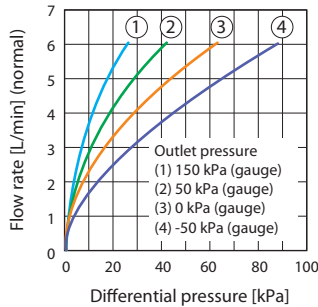

● F4H0020

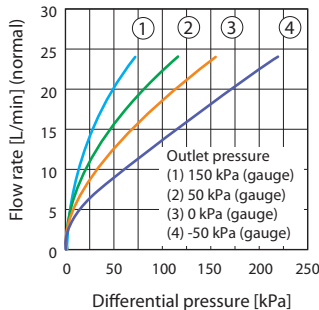

■ Optional parts (sold separately)

Item	Model Number	Remarks
USB cable	81441177-001	For PC loader *Please download the PC loader software from our Compo Club website at http://www.compoclub.com .
AC adapter	81446957-001	Input rating: 100–240 V AC, 50/60 Hz, 0.4 A Output rating: 24 V DC, 750 mA Operating temperature range: 0 to 40 °C
Rc 1/4 fitting	81446834-001	Two
1/4 Swagelok fitting or equivalent	81447653-001	O-rings included. Fluoroelastomer, degreased fittings
1/4 VCR fitting or equivalent	81447654-001	

■ External Dimensions

Unit: mm

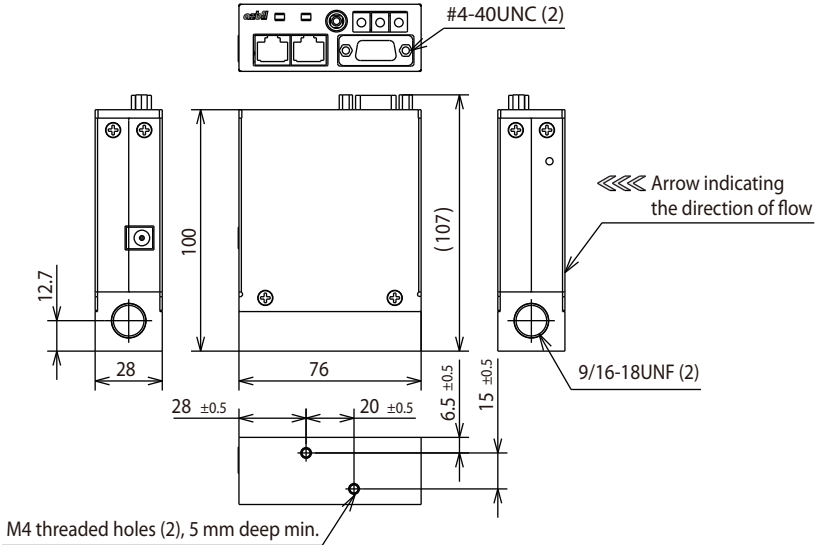

1/4 BI-LOK fitting type
(equivalent to Swagelok fitting)

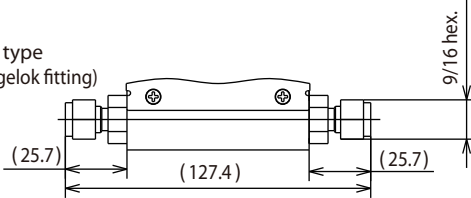

1/4 VTF fitting type
(equivalent to VCR fitting)

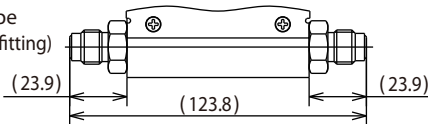

1/4 Rc connection type

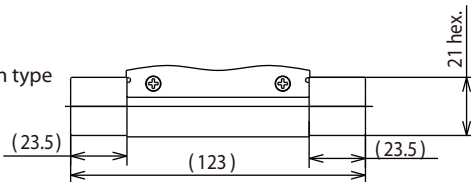

● AC adapter (part number: 81446957-001)

Unit: mm

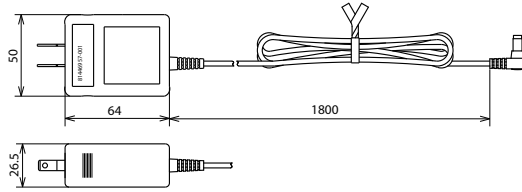

Memo

Safety Sheet

In accordance with the amendment of the Industrial Safety and Health Act, which came into effect on April 1, 2006, Azbil Corporation asks its customers to attach a copy of this Safety Sheet when sending in a device for repair.

The Safety Sheet is intended to ensure that the customer's device is safe for repair personnel and to ensure environmentally proper handling.

Azbil Corporation cannot work on a device that is not accompanied by the Safety Sheet. Also, it may be necessary for Azbil Corporation to ask the customer to resubmit the Safety Sheet.

Please complete the Safety Sheet and include it in the shipping box with your device.

Please copy this page.

To Azbil Corporation	Statement by the End User
I attest to the safety of this device based on the following (circle the applicable item):	
<ul style="list-style-type: none">• The device has been decontaminated.• No hazardous material was used in this device.	
Model number: _____	
Date code: _____	
Serial number: _____	
Date	Company name: _____
	Department: _____
	Name (signature): _____
	Approved by (signature): _____
	Phone: _____
Comments or supplementary information: _____	

Dealer/Agent/Salesperson Information (for Azbil Corp. internal use only)	
Date	Company name: _____
	Department: _____
	Name (signature): _____
	Phone: _____
Date	Company name: _____
	Department: _____
	Name (signature): _____
	Phone: _____

[Important Notice]

Depending upon the degree of contamination of the device, Azbil Corporation reserves the right to refuse repair. Thank you for your understanding.

[Handling of personal information]

We will use personal information provided to us only for the purpose of providing after-sales services to you.

azbil

Specifications are subject to change without notice. (09)

Azbil Corporation
Advanced Automation Company

1-12-2 Kawana, Fujisawa
Kanagawa 251-8522 Japan

URL: <http://www.azbil.com>

1st edition: Jan. 2017 (V)
2nd edition: June 2018