

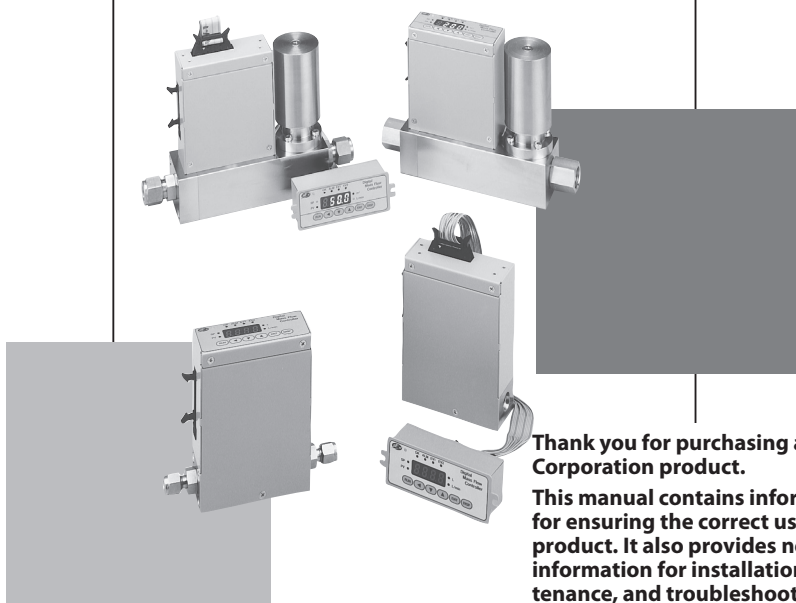

Digital Mass Flow Controller For Hydrogen and Helium Gases

MQV9020/9050/9500/0005/
0010/0050/0200

User's Manual



Thank you for purchasing an Azbil Corporation product.

This manual contains information for ensuring the correct use of this product. It also provides necessary information for installation, maintenance, and troubleshooting.

This manual should be read by those who design and maintain equipment that uses this product. Be sure to keep this manual nearby for handy reference.

Azbil Corporation

Please read "Terms and Conditions" from the following URL before ordering and use.

<http://www.azbil.com/products/factory/order.html>

NOTICE

Be sure that the user receives this manual before the product is used.

Copying or duplicating this user's manual in part or in whole is forbidden. The information and specifications in this manual are subject to change without notice.

Considerable effort has been made to ensure that this manual is free from inaccuracies and omissions. If you should find an error or omission, please contact the azbil Group.

In no event is Azbil Corporation liable to anyone for any indirect, special or consequential damages as a result of using this product.

© 2006–2017 Azbil Corporation All Rights Reserved.

Micro Flow™, μF™ and μF sensor™ are trademarks of Azbil Corporation in Japan.

Conventions Used in This Manual

- The safety precautions explained in the following section aim to prevent injury to the operator and others, and to prevent property damage.

 **WARNING** Warnings are indicated when mishandling this product might result in death or serious injury.

 **CAUTION** Cautions are indicated when mishandling this product might result in minor injury to the user, or physical damage to the product.

- In describing the product, this manual uses the icons and conventions listed below.



Use caution when handling the product.



The indicated action is prohibited.



Always follow the indicated instructions.

Handling Precautions

Handling Precautions indicate items that the user should pay attention to when handling the product.



Note

Notes indicate information that might benefit the user.



This indicates the item or page that the user is requested to refer to.



This font indicates what is shown on the 7-segment display.



This is an LED indicator on the display.





This is an operation key.







This indicates the result of an operation or the state after the operation.

Safety Precautions

WARNING

-  Never allow gases that are within explosion limits (in particular, mixed gases within explosion limits that contain hydrogen) to pass through this device. Doing so might result in an explosion accidents.
-  When using this device for gases that contain hydrogen, be sure to purge the device with an inert gas (such as nitrogen or argon) before use. Use without purging may cause an explosion.

CAUTION

-  If the device is used for burner air-fuel ratio control, take the necessary countermeasures with the equipment to prevent the occurrence of backfire and to avoid any influence to the device even if backfire occurs. Pressure increase or fire in the pipes caused by the backfire of the burner could damage the controller.
-  This device is exclusively for hydrogen and helium gases. It cannot be used for control or measurement of gases other than hydrogen, helium, and hydrogen-helium mixtures (excluding mixed gases within explosion limits). Oxygen cannot be measured even if gas-contacting sections of this device are oil-inhibited.
-  This device is set initially for hydrogen gas use at the factory. To use it for helium gas or mixed gases, change the gas type setting. The use of this device for helium or mixed gases without changing the gas type setting will result in a measurement error.
-  Prevent foreign matter from entering the device. If rust, water droplet, oil mist, or dust in the pipes enters the device, measurement or control error or damage might occur.
If there is a possibility of foreign matter entering the device, provide a filter, strainer or mist trap capable of eliminating foreign matter 0.1 μm or greater in diameter at the upstream. Be sure to inspect and replace the filter at regular intervals.
-  Use the device within the operating differential pressure range. Also, do not subject it to pressure beyond the rated pressure resistance range. Doing so might damage it.

CAUTION

 The valve on this device cannot completely shut a flow off. If complete shutoff is required, provide a shutoff valve separately. When the external valve is closed, it is necessary also to fully close the valve of the device using either of the following methods:

- Set the flow rate setpoint to zero.
- Make the valve operation mode to fully closed.

If this valve remains in normal control status when the external shutoff valve is closed (zero flow rate), there will be an excessively large flow as soon as the external shutoff valve is opened. This excessive flow rate could activate the AL83 alarm (operated by the sensor safety circuit). If the sensor safety circuit is activated, flow rate measurement and flow control are not possible until the power is turned off and back on again.

 Before connecting pipes with Swagelok or VCR connections, check the precautions in the instruction provided by the connecting joint manufacturer.

When separately purchasing a connecting joint, use the following made by Swagelok Co., Ltd:

1/4" Swagelok:	SS-400-1-6STSC11
1/4" VCR:	SS-4-VCR-1-00032SC11

 The device is a precision instrument. Do not drop it or subject it to impact, or it might be damaged.











 When installing joints (UNF connections), secure the lower part of the body in a vise or the like gripped between rags to protect the finished surfaces, and turn the joint to tighten. The device may be damaged if the lower body is not secured.

 Mount securely in order to prevent vibration. Otherwise, equipment failure could result.

 Mount the device horizontally. Do not mount it with the display facing down. Doing so might cause measurement error or equipment failure.



CAUTION

	When making the pipe connections, hold the hexagonal part of the connector section and turn the pipe to tighten. After connecting, check that there are no gas leaks.
	If using Rc connections, take care not to coat with too much sealant. Foreign matter or burrs in the pipes may also cause measurement errors.
	Do not apply a negative voltage or a voltage exceeding 5V to the external setup voltage input terminal. Doing so might cause malfunction or equipment failure.
	When using a relay for external contact input and/or external 3-way switching input, always use a relay designed for micro-current use (with gold contacts). Failure to do so could cause faulty contact, resulting in malfunction.
	If there is a risk of a power surge caused by lightning, use Azbil Corporation's SurgeNon to prevent possible fire or equipment failure.
	Gas type switching by external contact input, flow rate switching, and analog input/output voltage range switching by external 3-way input switching should be done only after setting the operation mode to fully closed. Switching while controlling could cause large fluctuations.
	Be sure to check that the wiring is correct before turning the power on. Incorrect wiring could cause damage or malfunction.
	Do not apply excessive force to cables or connectors when connector cables or the AC adapter is attached. Excessive force may damage the connectors or circuit board.
	Do not operate the console keys using a sharp object such as a mechanical pencil or screwdriver. Doing so might damage the console.
	When discarding the device, dispose of it as industrial waste, following local regulations.

The Role of This Manual

A total of 2 different manuals are available for the MQV. Read them as necessary for your specific requirements. If a manual you require is not available, contact the azbil Group or its dealer.

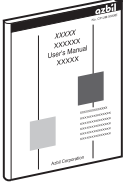

Digital Mass Flow Controller For Hydrogen and Helium Gases MQV 9020/9050/9500/0005/0010/0050/0200 User's Manual **Manual No. CP-SP-1205E**

This manual.

Personnel who are using the MQV digital mass flow controller (for hydrogen and helium gases) for the first time or who are in charge of hardware design and/or maintenance of equipment containing the MQV should read this manual thoroughly.

This manual gives an overview of the product, describes installation, wiring, operation, maintenance, and troubleshooting, and gives hardware specifications.

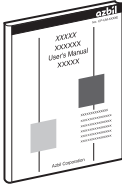

CMQ-V Series Digital Mass Flow Controller User's Manual Communications **Manual No. CP-SP-1197E**

Personnel who use this device's communications functions should read this manual.

The manual gives an overview of communications, describes wiring, transmission protocols, communications data, and troubleshooting, and gives communications specifications.

Organization of the Manual

This manual is organized as follows.

Chapter 1. INTRODUCTION

This chapter briefly describes this device and its features, and gives a model selection guide.

Chapter 2. NAMES AND FUNCTIONS OF PARTS

This chapter describes the names and functions of this device's parts.

Chapter 3. MOUNTING AND WIRING

This chapter describes installation, mounting, wiring and initial settings of this device.

Chapter 4. BASIC OPERATION

This chapter gives the basis of how to operate this device.

Chapter 5. ADVANCED OPERATION

This chapter describes how to set functions, parameters, device information display, and flow rate range.

Chapter 6. TROUBLESHOOTING

This chapter describes how to investigate and remedy trouble that may occur during operation of this device.

Chapter 7. SPECIFICATIONS

This chapter describes the device's specifications and external dimensions.

Contents

Conventions Used in This Manual

Safety Precautions

The Role of This Manual

Organization of the Manual

Chapter 1.	INTRODUCTION	1-1
	■ Introduction.....	1-1
	■ Features.....	1-1
	■ Functions.....	1-2
	■ Model selection guide.....	1-7
	■ Basic operation and advanced operation.....	1-8
Chapter 2.	NAMES AND FUNCTIONS OF PARTS	2-1
	■ Display.....	2-1
Chapter 3.	MOUNTING AND WIRING	3-1
	■ Mounting.....	3-2
	■ Piping.....	3-6
	■ Wiring.....	3-7
Chapter 4.	BASIC OPERATION	4-1
	■ Basic operation.....	4-1
	■ Digital flow rate setup.....	4-5
	■ Flow rate setup by external contact input (Advanced use).....	4-7
	■ Flow rate setup by external 3-way switching input (Advanced use).....	4-8
	■ Analog flow rate setup.....	4-9
	■ Operating mode selection.....	4-10
	■ Operating mode display.....	4-10
Chapter 5.	ADVANCED OPERATION	5-1
	■ Setup mode transition operation.....	5-1
	■ Setup method.....	5-2
	■ Function setup items.....	5-3
	■ Parameter setup item list.....	5-12
	■ Setup method.....	5-15
	■ Device information display item.....	5-16
	■ Setup resolution in the analog setup.....	5-17

Chapter 6.	TROUBLESHOOTING	6-1
	■ Alarm code display.....	6-1
	■ Troubleshooting guide.....	6-3
Chapter 7.	SPECIFICATIONS	7-1
	■ MQV9020/9050.....	7-1
	■ MQV9500/0005/0010.....	7-3
	■ MQV0050/0200.....	7-5
	■ Korea Certification Mark.....	7-7
	■ Gas type and control range.....	7-8
	■ China RoHS.....	7-8
	■ Relationship between differential pressure and flow rate (For Hydrogen).....	7-9
	■ Relationship between differential pressure and flow rate (For Helium).....	7-10
	■ Optional parts (sold separately).....	7-11
	■ External dimensions.....	7-12

Chapter 1. INTRODUCTION

■ Introduction

MQV high performance, digital mass flow controllers with advanced functions have been developed for the general industrial application. They feature flow rate control with high speed and wide range ability. MQV controllers integrate three component technologies: the ultra quick response μF (Micro Flow) thermal flow sensor, made with proprietary Azbil Corporation technology, a proportional solenoid valve, and advanced actuator control technology.

Integrating these technologies has achieved a high-speed control with low differential pressure.

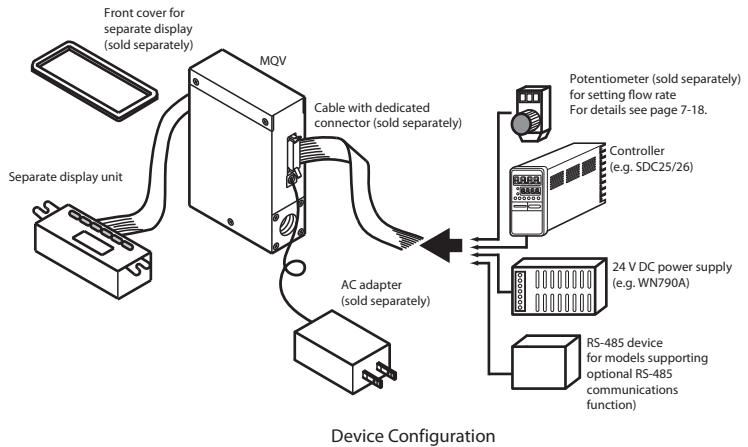

■ Features

- **High-speed controllability**
Fast response of 300 ms or less*
(500 ms for the MQV9020/9050.)
* Response time is the time required for the controlled flow rate to reach $\pm 2\%$ of the set value, starting from the fully closed state or from when the set value is changed during control.
- **Low differential pressure operation**
MQV controllers can operate at a low differential pressure of 50 kPa or less.
- **Wide control range**
Wide control range of 1 to 100% FS
- **Wide product line-up**
There are two types of models, those with integrated display and those with separate display. On models with separate display, the display unit can be detached to allow remote operation via the dedicated 2 m cable.

- **User-friendly**
Runs on a general-purpose 24 V DC power supply, and the MQV's internal power circuit and input/output circuits are isolated. When multiple MQV are driven through the analog inputs and outputs, as with a PLC, they can all use a common power supply even if the PLC's analog modules are not isolated by channel. Therefore, even without individual power supplies for each device, problems with one circuit do not affect adjacent ones. Also provided is a handy AC adapter (sold separately) for easy use in the laboratory.
- **Display direction can be changed (models with integrated display only)**
The direction of the display can be rotated 180° to match the direction of the gas flow, in case it was mounted the other way.
- **Improved design (separate display model)**
A front cover (sold separately) hides the mounting screws of the separate display on the panel surface and improves the appearance.
- **Various additional functions**
The functions listed below are all standard.

■ Functions

All MQV models have the functions described below. For function setup, ➔ Chapter 5. ADVANCED OPERATION

- **Multi-setup (function setup ξ - 24)**
Quickly switch to one of eight preset flow set value by key operation or external input. If "Switching of SP No." is set to external 3-way switching input, up to three set values can be switched.
- **Gas type switching (function setup ξ - 18, ξ - 25)**
The gas type to be used can be selected from the standard compatible gases by key operation. Additionally, two kinds of gas type settings can be changed by external contact input.
- **Gas type setup (function setup ξ - 18)**
The user can set gas type conversion factors for gases other than the standard compatible gases, and for mixed gases.
- **Control flow rate range setting (function setup ξ - 24, ξ - 25)**
The control flow range can be changed to the desired range (10 to 100% of the flow range at factory setting) in units of 1% FS. The setup and display resolution levels can be improved by reducing the control flow range. Additionally, two kinds of control flow ranges can be switched through external contact input.

-
- Direct setup (function setup $\xi - 21$)
When changing the flow set value by key input, the controlled flow rate can follow the set value while changes are being made (the flow set value can be changed quickly). This function is useful when the user frequently changes set value, for example when adjusting the flow set value during a trial run.
 - SP ramp control (function setup $\xi - 27$)
This function is used to set the set value change ramp amount (the rate of change per second) to a constant value for the start of control and for set value changes. With this function, the set value change ramp amount can be set more precisely than with the slow start function. Two different types of ramps can be set, and there are the following 2 control modes:
 - SP ramp control 1
In SP ramp-up: Ramp 1
In SP ramp-down: Ramp 2
 - SP ramp control 2
In external contact OFF: Ramp 1
In external contact ON: Ramp 2
 - SP limit (function setup $\xi - 35$)
The lower and upper limits of the set value range can be set to desired levels. (This prevents mistaken high/low settings.)
 - Slow start (function setup $\xi - 47$)
Sudden changes in the controlled flow rate, when control is started or when the set value is changed, can be suppressed. The control speed can be changed in eight stages within a range of about 1 to 6 seconds.
 - Flow rate totalization (function setup $\xi - 09, \xi - 12$)

MQV9020/9050:	in 1 mL units
MQV9500:	in 0.01 L units
MQV0005:	in 0.1 L units
MQV0010/0050:	in 1 L units
MQV0200:	in 0.01 m ³ units

Integrated flow count can be up to eight digits long (to 99,999,999) for each unit. (Display alternates between first and last 4 digits.)
The count can be reset by key operation or external contact input. Use of external contact input makes it possible to remotely operate the start, temporary stop, and reset of totalization. When resetting the integrated count by key operation, the count restarts automatically after it has been reset. On the other hand, when resetting with the external contact input (by contact ON), the count restarts when the contact is turned OFF.

- Event lamp lighting/output (function setup $\xi - 07, \xi - 08$)
Two of the event types listed below can be selected. Output ON delay time can also be set (but delay cannot be set for totalizer pulse output).
 - Integrated flow event output (when the integrated flow event setting is exceeded.)
 - Totalized pulse output (pulse can be output for each totalizing flow display unit.)
 - OK output (the control flow rate is within the set value \pm allowable range.)
 - Flow rate upper or lower limit output (output in comparison with optional upper or lower limit flow rate set value)
 - Output mode (The four modes — control / fully open / control or fully open / fully closed — can be identified and output.)
- OK lamp ON/output (function setup $\xi - 07, \xi - 08$)
The OK lamp can be set to light when the control flow rate is within the set value \pm allowable range. This function is very handy for verifying at a glance whether or not there is a proper response to a new set value after its value is changed. OK lamp output can also be used as an interlock signal for subsequent processes by assigning it to event output and including it in a sequence program.
- PV filter (function setup $\xi - 23$)
This function is used to average the detected instantaneous flow rates (control flow rates). It can also reduce the effect of slight pressure fluctuations.
- Control dead band setup (prevention of valve operation) (function setup $\xi - 22$)
This function is used to stop the valve from driving as long as the control flow rate is within the OK range. Additionally, the OK range (width of dead band) can be set to the desired level.
- Valve amperage display (function setup $\xi - 20$)
The electric current supplied to the valve can be displayed in units of 0.0 to 100.0%. Additionally, use of the valve amperage alarm detection function makes it possible to detect an inlet pressure change or clogging of the piping at the outlet.
- Gas type external switching (function setup $\xi - 10$ to $\xi - 12, \xi - 18, \xi - 28$)
Two preset types of gases (including one with a user-determined gas type conversion factor) can be switched by external contact input.
- Control flow rate range external switching (function setup $\xi - 10$ to $\xi - 12, \xi - 24, \xi - 25$)
Two preset control flow ranges can be switched by external contact input.

- PV forced zero (function setup $\zeta - 29$)
This function forcibly sets the detected instantaneous flow rate to 0 (zero) after the delay time elapses when the flow rate setpoint has been set to 0 (zero) or the valve mode has been changed to fully closed. This function makes it possible to ignore the deviation of the instantaneous flow rate zero point caused by inclination of the piping or the like.
- Flow rate display unit change (function setup $\zeta - 37$)
This function is used to change the flow rate display unit to L/min or mL/min of the MQV9500/0005. When multiple devices are used side-by-side, this function can make the flow rate display units uniform.
- PV display decimal point change (function setup $\zeta - 38$)
This function is used to shift the decimal point position of the instantaneous flow rate display one digit left or right. When multiple devices are used side-by-side, the number of digits after the decimal point of the flow rate display can be made uniform.
- Valve forcibly open or close (function setup $\zeta - 02, \zeta - 09$ to $\zeta - 12$)
This function is used to forcibly open or close the valve fully by key operation, external contact input, or external 3-way switching input.
- Automatic shut-off (function setup $\zeta - 13, \zeta - 15$)
The valve can be shut off automatically under the following conditions:
(1) When the totalized flow count reaches the preset value.
(2) When one of the alarms, including flow rate alarms, is triggered.
- ALM (alarm) lamp ON/output/valve shut-off (function setup $\zeta - 15, \zeta - 16, \zeta - 20$)
The alarm output can be set for high and low deviations in the flow set value and instantaneous flow rate. Additionally, an alarm judgment delay time can also be set. If a flow rate alarm occurs or if an alarm occurs during self diagnosis of this controller, the valve can be forced fully closed or opened.

! Handling Precautions

- The valve on this device cannot completely shut off.
- If complete shutoff is required, provide a shutoff valve separately.
- Automatic reset of totalized flow at start of control function (function setup $\zeta - 14$)
Start of control and reset of totalized flow count can be done simultaneously by a single action (by key or external switching input). Combining this function with the automatic shut-off function described above is handy for shutting the valve off in cases where a fixed totalized flow amount is counted repeatedly.

- Analog scaling (function setup $\xi - 28$)

This function is used to optionally change the flow rate (between 10% FS and 100% FS) corresponding to 100 % FS analog input/output (5 V or 20 mA).

- Analog input (flow set value) range selection (function setup $\xi - 35, \xi - 39$)

In analog setup, the desired input range can be selected from those shown below either by key operation or by external 3-way switching input. When doing so, the voltage input and current input are selected automatically, as they are linked with the settings of function setup $\xi - 36$ (analog output type selection). For example, when the voltage output (0 to 5 V or 1 to 5 V) is selected in $\xi - 36$, the voltage input is selected automatically. Likewise, when the current output (0 to 20 mA or 4 to 20 mA output) is selected, the current input is selected automatically.

- (1) Internal reference 0 to 5 V input*/External reference 0 to 20 mA input
 - (2) External reference 0 to 5 V input/External reference 0 to 20 mA input
 - (3) External reference 1 to 5 V input/External reference 4 to 20 mA input
- *0-5 V internal-reference is used when the 5 V output terminal (pin No. 20) of this controller is used as the reference.

- Analog output type/range selection (function setup $\xi - 36, \xi - 39$)

Output can be set either to instantaneous flow rate (PV) or flow set value (SP). Furthermore, a voltage/current output range can be selected from (1) to (4) shown below by key operation. Additionally, (1)/(2) or (3)/(4) can be changed through the external 3-way switching input. (Combinations are switched because of linkage with the analog input range selection.)

<u>Instantaneous flow rate (PV) output</u>	<u>Flow set value (SP) output</u>
(1) 0 to 5 V output	(1) 0 to 5 V output
(2) 1 to 5 V output	(2) 1 to 5 V output
(3) 0 to 20 mA output	(3) 0 to 20 mA output
(4) 4 to 20 mA output	(4) 4 to 20 mA output

■ Model selection guide

● MQV9020/9050

Basic model Nos.	Standard control flowrate range	Display	Material of gas-contacting parts	Connection method	Gas type	Optional functions					Appended No.	Description
						1	2	3	4	5		
MQV												Digital mass flow controller
	9020											0.2–20.0 mL/min (standard) *1
	9050											0.4–50.0 mL/min (standard) *1
		B										Integrated display (body length: 90 mm)
		C										Separate display (body length: 90 mm)
			S									SUS316
				S								1/4" Swagelok
				V								1/4" VCR
					H							Hydrogen *2
					0							Without optional functions
					0							Without optional functions
					1							Model with RS-485 communications (CPL)
						0						Without optional functions
							1					Gas-contacting parts treated to be oil free
								0				Without optional functions
								D				With inspection certificate
								Y				With traceability certificate
									0			Product version

● MQV9500/0005/0010/0050/0200

Basic model Nos.	Standard control flowrate range	Display	Material of gas-contacting parts	Connection method	Gas type	Optional functions					Appended No.	Description
						1	2	3	4	5		
MQV												Digital mass-flow controller
	9500											0.004–0.500 L/min (standard) *1
	0005											0.04–5.00 L/min (standard) *1
	0010											0.10–10.00 L/min (standard) *1
	0050											0.4–50.0 L/min (standard) *1
	0200											2–200 L/min (standard) *1
		B										Integrated display (body length 90 mm)
		C										Separate display (body length 90 mm)
			S									SUS316
				R								Rc 1/4"
				S								1/4" Swagelok
				V								1/4" VCR
				U								9/16-18UNF
					H							Hydrogen *2
					0							Without optional functions
					0							Without optional functions
					1							Model with RS-485 communications (CPL)
						0						Without optional functions
							1					Gas-contacting parts treated to be oil free
								0				Without optional functions
								D				With inspection certificate
								Y				With traceability certificate
									0			Product version

Notes: *1. The unit L/min (standard) indicates the volumetric flow rate per minute converted to 20 °C, 101.325 kPa (one atmosphere). The reference temperature can also be changed to 0 °C, 25 °C and 35 °C.

*2. This device is set initially for hydrogen gas use at the factory. It can be used for helium gas by changing the gas type setting.

■ Basic operation and advanced operation

This device provides two kinds of operations, basic operation and advanced operation. Basic operation is the state of the device during normal use. In basic operation, the contents of the 7-segment display can be changed to show instantaneous flow rate, flow set value, totalized flow value, or amperage to the valve in normal operation mode. Also, how to set the flow set value is described in the basic operation part.

Advanced operation is for selecting various functions or setting parameters of the device. When the device is used with the factory settings, no setup operation is needed. However, to change the gas type, set a range, set an external contact input, set upper and lower alarm limits, or set communication conditions (for models with communication functions), it is necessary to configure various settings using advanced operation. The diagram below gives an outline of operation flow. Basic and advanced operation are described in Chapters 4 and 5, respectively.

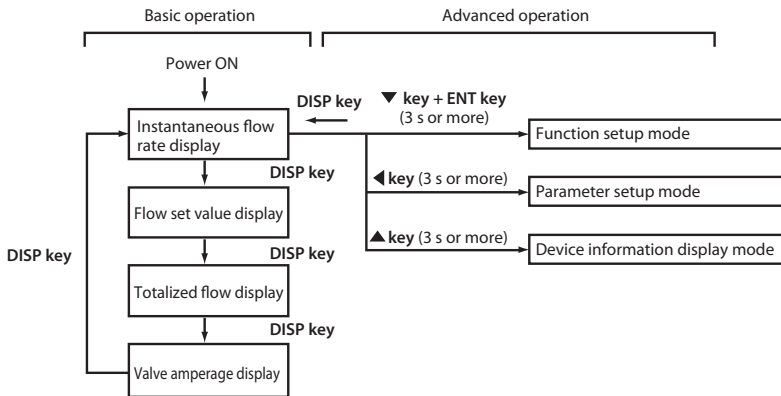

Chapter 2. NAMES AND FUNCTIONS OF PARTS

■ Display

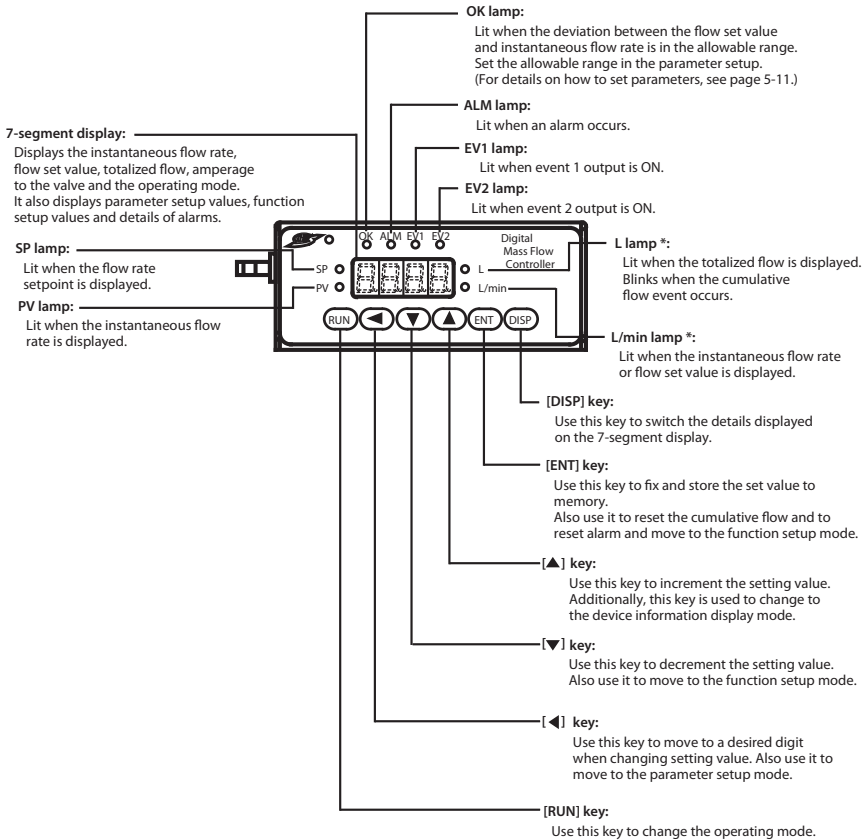

*1 The "L" lamp is labeled "m³" on the MQV0200.

*2 The "L/min" lamp is labeled "mL/min" on the MQV9020/ 9050

Note

- Technical terms used in this manual are defined as follows:
 - SP (setpoint): The flow set value (or flow rate set point)
 - PV (process variable): Instantaneous flow rate (or controlled flow rate)
 - Operating mode: One of 3 modes (valve fully closed/valve control/

● **Body (MQV9020/9050/9500/0005/0010/0050/0200)**

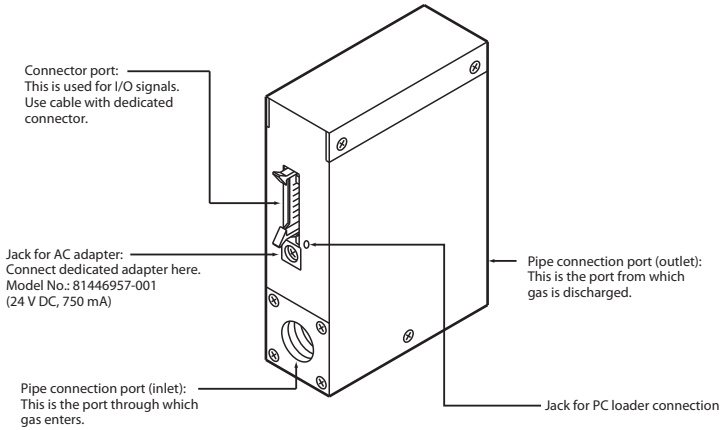

! Handling Precautions

- The former AC adapter (model No. 81446682-001, 15 V DC/350 mA) can not be used with MQV.

Chapter 3. MOUNTING AND WIRING

WARNING



Never allow gases that are within explosion limits (in particular, mixed gases within explosion limits that contain hydrogen) to pass through this device. Doing so might result in an explosion accidents.



When using this device for gases that contain hydrogen, be sure to purge the device with an inert gas (such as nitrogen or argon) before use. Use without purging may cause an explosion.

CAUTION



Prevent foreign matter from entering the device. If rust, water droplet, oil mist, or dust in the pipes enters the device, measurement or control error or damage might occur. If there is a possibility of foreign matter entering the device, provide a filter, strainer or mist trap capable of eliminating foreign matter 0.1 μm or greater in diameter at the upstream. Be sure to inspect and replace the filter at regular intervals.



This device is exclusively for hydrogen and helium gases. It cannot be used for control or measurement of gases other than hydrogen, helium, and hydrogen-helium mixtures (excluding mixed gases within explosion limits). Oxygen cannot be measured even if gascontacting sections of this device are oil-inhibited.



This device is set initially for hydrogen gas use at the factory. To use it for helium gas or mixed gases, change the gas type setting. The use of this device for helium or mixed gases without changing the gas type setting will result in a measurement error.



Use the device within the operating differential pressure range. Also, do not subject it to pressure beyond the rated pressure resistance range. Doing so might damage it.



The valve on this device cannot completely shut a flow off. If complete shutoff is required, provide a shutoff valve separately. When the external valve is closed, it is necessary also to fully close the valve of the device using either of the following methods:

- Set the flow rate setpoint to zero.
- Make the valve operation mode to fully closed.

If this valve remains in normal control status when the external shutoff valve is closed (zero flow rate), there will be an excessively large flow as soon as the external shutoff valve is opened. This excessive flow rate could activate the FLBB alarm (operated by the sensor safety circuit). If the sensor safety circuit is activated, flow rate measurement and flow control are not possible until the power is turned off and back on again.



Before connecting pipes with Swagelok or VCR connections, check the precautions in the instruction provided by the connecting joint manufacturer.

When purchasing a connecting joint, use the following made by Swagelok Co., Ltd:

- 1/4" Swagelok: SS-400-1-6STSC11
- 1/4" VCR: SS-4-VCR-1-00032SC11



The device is a precision instrument. Do not drop it or subject it to impact, or it might be damaged.

■ Mounting

● Installation locations

Avoid mounting the device in the following locations:

- Locations subject to high and low temperature and humidity
- Locations whose atmospheres contain large amounts of dirt and dust, salt, conductive substances such as iron powder, water droplet, oil mist or organic solvents
- Locations subject to direct sunlight and rain
- Locations directly subject to mechanical vibration or shock
- Locations close to sources of electrical noise
- Locations where strong magnetic or electrical fields are generated

! Handling Precautions

- The valve of this device cannot completely shut a flow off. If complete shutoff is required, provide a shutoff valve separately.

● Changing the display direction (models with integrated display only)

The display can be turned 180°, in case the controller has been mounted with the display upside-down.

● Procedure

- (1) Turn the power OFF.
- (2) Remove the four screws holding the display.
- (3) Lift up the display from the body, and turn it 180° counterclockwise.

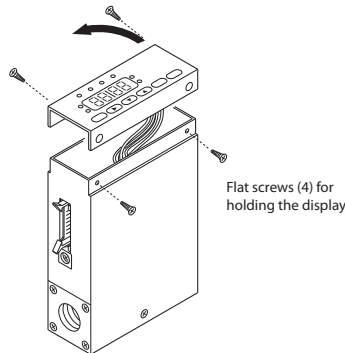

- (4) Put the display back on the body, and fasten with the four screws taken off in step (2).
- (5) To return the display to its original position on the body, turn it 180° clockwise.

! Handling Precautions

- Before changing the display direction, be sure to turn the power OFF.
- Prevent foreign objects from falling inside the body when the display is taken off. Failure to do so might cause trouble or malfunction.
- Do not remove the connectors used inside the device.

● Installing joints (UNF connections)

⚠ CAUTION

! When installing joints (UNF connections), secure the lower part of the body in a vise or the like gripped between rags to protect the finished surfaces, and turn the joint to tighten. The device may be damaged if the lower body is not secured.

When using a standard type UNF connection, install the joint first (except when the pipe is directly connected).

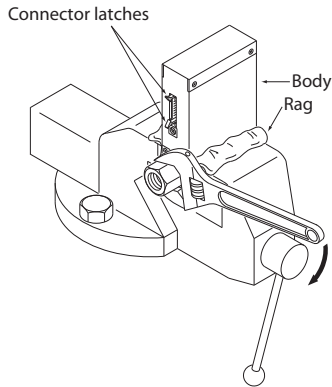

● **!** Handling Precautions

- Do not hold the top part of the body with your hand. Doing so might deform the case.

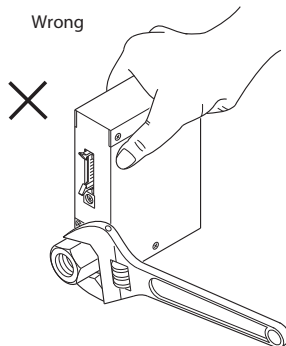

- Take special care not to damage the connector latches.

● Installation procedure

CAUTION

- ! Mount securely in order to prevent vibration. Otherwise, equipment failure could result.
- ! Mount the device horizontally. Do not mount it with the display facing down. Doing so might cause measurement error or equipment failure.

● MQV9020/9050/9500/0005/0010/0050/0200

Install the device with two M4 screws using the mounting holes on the base of the device. Unit: mm

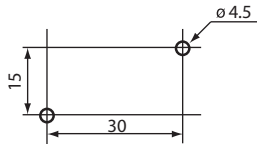

● Installing the separate display unit

For models with a separate display

- (1) Make mounting holes in the panel according to the panel cutout dimensions. Unit: mm

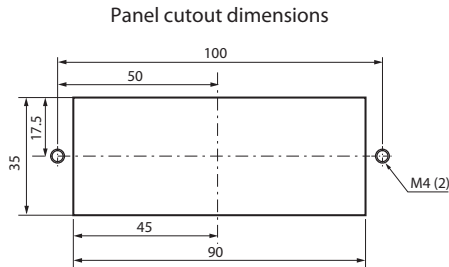

- (2) Mount the display and secure it by tightening the screws.

● Installing the front cover for the separate display unit

For models with a separate display, a front cover (decorative frame) can be mounted. Use of this cover makes it possible to hide the mounting screws, improving the appearance.

Items needed for installation

- Front cover (81446858-001), 1 set
- Phillips screwdriver

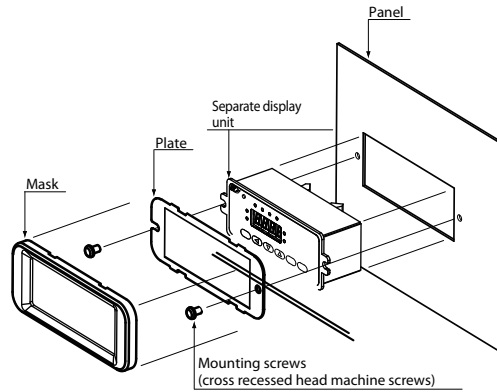

Note



- The front cover set includes one mask, one plate, and two mounting screws.

Procedure

- (1) As shown in the figure, put the plate over the display panel, and then secure it to the display by tightening the screws.
- (2) Fit the mask onto the display to mount it.

■ Piping

CAUTION

-  **Mount the device horizontally. However, do not mount it with the display facing down.**
Doing so might cause measurement error or equipment failure.
-  **When making the pipe connections, hold the hexagonal part of the connector section and turn the pipe to tighten. After connecting, check that there are no gas leaks.**
-  **If using Rc connections, take care not to coat with too much sealant. Foreign matter or burrs in the pipes may also cause measurement errors.**

Handling Precautions

- Make sure that the gas flows into the device in the direction indicated by the FLOW arrow on the body. Otherwise, the flow rate cannot be controlled correctly.
- Do not touch the pipe sections of a controller treated to be oil-free with your bare hands. Doing so will degrade the oil-free treatment.
- Do not hold the top part of the body with your hand when connecting piping. Doing so might deform the case.

Fasten and connect pipes to the body using a wrench (spanner) or similar tool on the hexagonal sections of the joints.

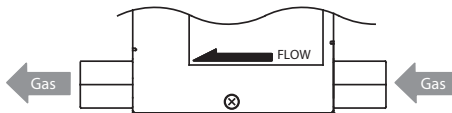

● Coating sealant (Rc connection)





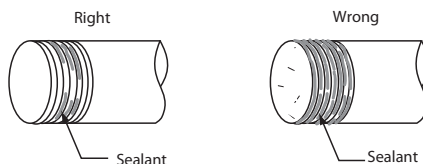

● Handling Precautions

- Coat with an appropriate amount of sealant. Do not coat the top two threads. Remove any dirt or burrs from inside the pipes.



■ Wiring

⚠ CAUTION

-  Do not apply a negative voltage or a voltage exceeding 5V to the external setup voltage input terminal. Doing so might cause malfunction or equipment failure.
-  When using a relay for external contact input and/or external 3-way switching input, always use a relay designed for micro-current use (with gold contacts). Failure to do so could cause faulty contact, resulting in malfunction.
-  If there is a risk of a power surge caused by lightning, use Azbil Corporation's SurgeNon to prevent possible fire or equipment failure.
-  Gas type switching by external contact input, flow rate switching, and analog input/output voltage range switching by external 3-way input switching should be done only after setting the operation mode to fully closed. Switching while controlling could cause large fluctuations.
-  Be sure to check that the wiring is correct before turning the power on. Incorrect wiring could cause damage or malfunction.
-  Do not apply excessive force to cables or connectors when connector cables or the AC adapter is attached. Excessive force may damage the connectors or circuit board.

● Connector pin layout

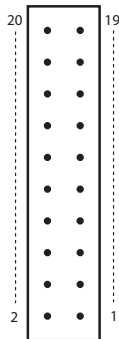

View from connector insertion side

Connector model No. (device side): HIF3BA-20PA-2.54DS

Manufacturer: HIROSE ELECTRIC CO., LTD.

● Table of compatible connectors (all made by HIROSE ELECTRIC CO., LTD.)

Connector type	Compatible connector model No.	Compatible contact model No.	Compatible wire
Contact crimp type	HIF3BA-20D-2.54C	HIF3-2226SCC	AWG#22 to #26 (single wire allowed)
Cable clamp type	HIF3BA-20D-2.54R	Not required	AWG#28 (flat cable only)

● Connector signal names

Pin No.	Signal name	Description	Notes
20	+5 V (5 mA max.)	5 V DC reference voltage output	5 mA max.
19	FLOW OUT	Instantaneous flow rate (PV) or flow rate setpoint (SP) output	0 to 5 V/1 to 5 V/0 to 20 mA/ 4 to 20 mA output
18	A.GND	Analog ground	Analog signal common
17	FLOW SP INPUT	Setpoint flow rate (SP) voltage input	0 to 5 V/1 to 5 V/0 to 20 mA/ 4 to 20 mA input
16	MODE INPUT	External 3-way switching input	3-stage switching input (OPEN/GND/5 V)
15	DI3	External contact input 3	2-stage switching input (OPEN/GND)
14	DI2	External contact input 2	
13	DI1	External contact input 1	
12	EV2 OUT	Event output 2	Open collector non-insulated output
11	EV1 OUT	Event output 1	
10	ALM OUT	Alarm output	
9	D.GND	Digital ground	Digital signal common
8	DB	RS-485 communications DB	Do not connect on models without the communications function.
7	DA	RS-485 communications DA	
6	D.GND	Digital ground	Digital signal common
5	TEST	For test	Do not use.
4	POWER GND	Power supply ground	Connect two wires each in parallel to the power supply to reduce voltage drop caused by wiring resistance.
3	POWER GND	Power supply ground	
2	POWER (24 V)	Power supply + (24 V DC)	
1	POWER (24 V)	Power supply + (24 V DC)	

● Wiring

● Power supply

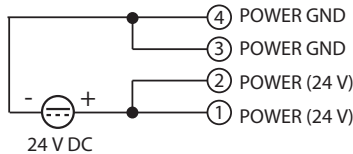

● RS-485 communications (for models with optional RS-485 only)

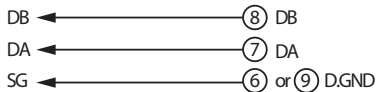

• Alarm output/event output

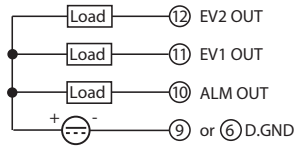

! Handling Precautions

- Take special care that the event and alarm outputs do not exceed the output rating of the device. Additionally, when driving a relay, use an appropriate coil surge absorption diode built-in relay. Failure to do so might cause the device to malfunction.

• External contact input

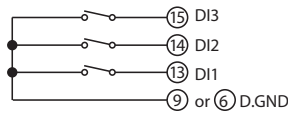

! Handling Precautions

- When switching by relay contact, use an appropriate relay intended for micro-current use (with gold contacts). Failure to do so could cause faulty contact, resulting in malfunction.

• Analog I/O

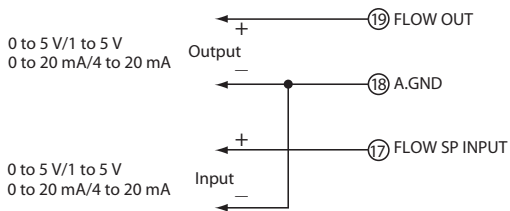

• When using potentiometer (0 to 5 V)

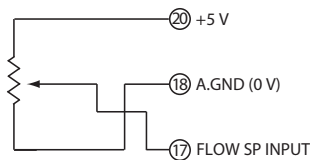

• External 3-way switching input

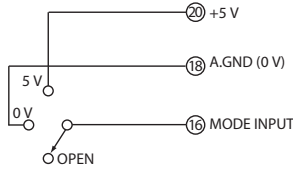

! Handling Precautions

- When switching by relay, use an appropriate relay intended for microcurrent use (with gold contacts). Failure to do so could cause faulty contact, resulting in malfunction.

Operation of external 3-way switching input

Input state of pin No.16		OPEN	GND	5V
		Assigned function		
Switching of operating mode 1		Control	Fully closed	Fully open
Switching of operating mode 2		Fully closed	Control	Fully open
Switching of SP No.		SP-0	SP-1	SP-2
Switching of totalizing operation		Continue counting	Reset	Stop counting
Switching of analog I/O voltage range	Input	Internal reference* 0 to 5 V or external reference 0 to 20 mA	External reference 0 to 5 V or 0 to 20 mA	External reference 1 to 5 V or 4 to 20 mA
	Output	0 to 5 V/0 to 20 mA	0 to 5 V/0 to 20 mA	1 to 5 V/4 to 20 mA

* "Internal reference" refers to the use of the 5Vdc reference voltage pin (No. 20) on this device, and is used when the setting value is set by an externally connected potentiometer.

📖 Note

- For details on how to assign external 3-way switching input functions, Chapter 5. ADVANCED OPERATION

● Example of wiring

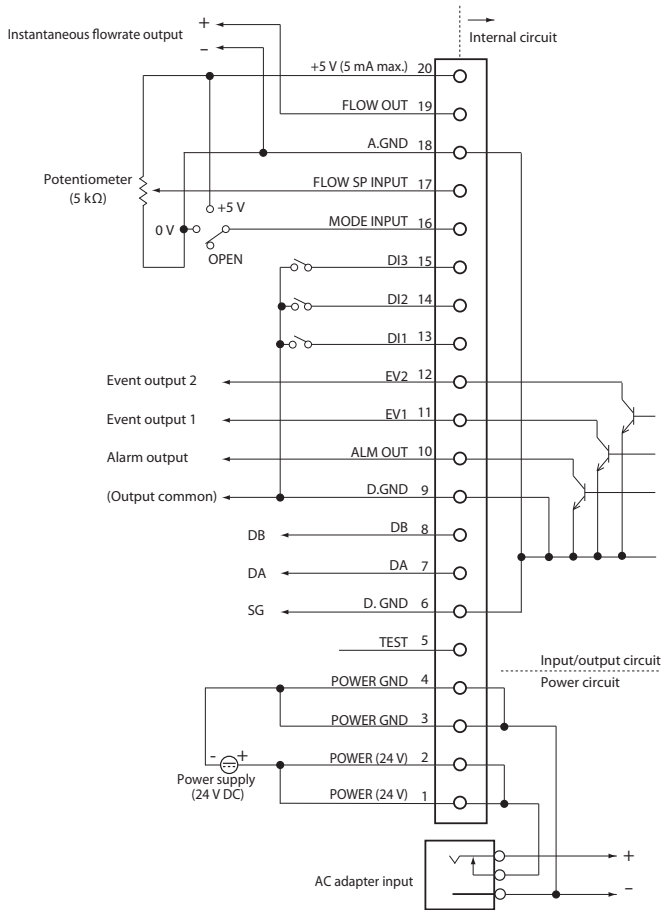

! Handling Precautions

- Do not input any signal to pin No. 5.
- The power circuit is isolated from the input/output circuit inside this device.
- Even though the analog GND and digital GND are connected internally, always carry out the grounding wiring individually.
- When the AC adapter plug is inserted into the AC adapter power supply terminal, the power supply changes from the DC power supply to the AC adapter.
- The former AC adapter 81446682-001 (15 V DC, 350 mA) cannot be used with this MQV.

● Connector terminal block

Sometimes two or more connections must be made to the same pin during wiring. In this case, use a connector terminal block. If you need a 20-core cable for the connectors on the device and connector terminal block, contact the azbil Group or your dealer.

 Note

- Recommended connector terminal block

Manufacturer: Toyo Giken

Model: PCN-1H-20

Mounting connector

HIROSE ELECTRIC CO., LTD., HIF3BA-20PA-2.54DSA

Compatible connector (other side)

HIROSE ELECTRIC CO., LTD., HIF3BA-20D-2.54R

 Handling Precautions

- The specifications of the recommended connector terminal block are subject to change. Contact the manufacturer beforehand for details.

This terminal block can be mounted directly on a DIN rail.

The following table shows the correspondence between connector pin Nos. and terminal block Nos.:

Pin No.	Terminal block No.
20	B-10
19	A-10
18	B-9
17	A-9
16	B-8
15	A-8
14	B-7
13	A-7
12	B-6
11	A-6
10	B-5
9	A-5
8	B-4
7	A-4
6	B-3
5	A-3
4	B-2
3	A-2
2	B-1
1	A-1

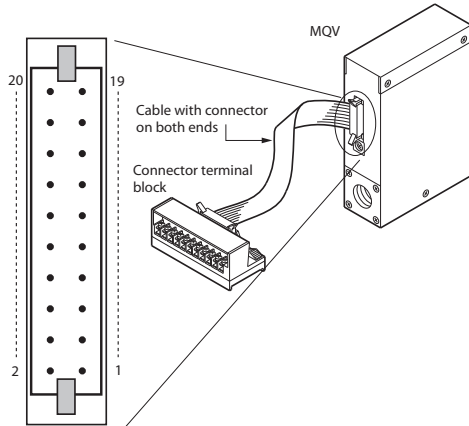

Chapter 4. BASIC OPERATION

4 - 1 Switching Displays

⚠ CAUTION



Do not operate the console keys using a sharp object such as a mechanical pencil or screwdriver. Doing so might damage the console.

■ Basic operation

Basic operation is used to change the display to instantaneous flow rate (PV), flow set value (SP), totalized flow value, or valve amperage.

Normally, when the power is turned ON, the instantaneous flow rate is displayed in basic operation mode. When this is the case, operating the [DISP] key changes the contents of the 7-segment display as described below.

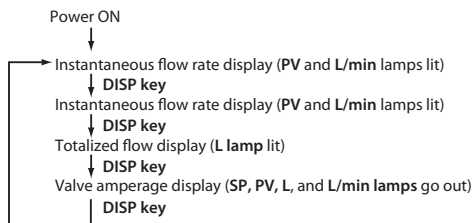

! Handling Precautions

- If there is no operator input for approximately 10 seconds while the flow set value is being displayed, the display automatically reverts to the instantaneous flow rate display.
- The "L" lamp is labeled "m³" on the MQV0200.

● Indicating instantaneous flow rate (PV display)

When the power is turned ON, the PV and L/min lamps light, and the instantaneous flow rate is indicated on the display.

! Handling Precautions

- When the operating mode is set to fully closed, and the flow rate is zero, and when the operating mode is switched to the control mode or fully open mode, the operating mode (OFF/ON/FULL) is displayed for about one second.
- When an alarm occurs, the alarm code and the PV are displayed alternately.

● Indicating the flow set value (SP display)

If [DISP] key is pressed while the instantaneous flow rate is displayed, the PV lamp goes out, the SP lamp lights and the flow set value (SP) is indicated on the display.

[!] Handling Precautions

- If the SP value is not changed for about 10 seconds while the flow set value is displayed, the instantaneous flow rate is redisplayed automatically. For details on how to change the flow rate, see section 4-2 Setting the Flow Rate (P. 4-4).
- When multiple setpoints (2 to 8 SPs) have been selected in $\zeta - 04$ in the function setup, when switching by external input, the flow set value SP value) is displayed for about one second, and then the display switches to the SP No.

● Indicating the totaled flow

When the [DISP] key is pressed while the flow set value (SP) is displayed, the SP and L/min lamps go out, the L lamp lights up, and the totaled flow value is indicated on the display.

When the totaled flow value is 10,000 or higher, the number is displayed in two parts, the last four digits, followed by the first four digits. When the value is the last four digits, the decimal point on the display is lit up.

For example, when the totaled flow value is "123,456L", "3456." is displayed.

Press the [DISP] key to display "123". To alternately display the first and last four digits, press the [◀] key.

[!] Handling Precautions

- When an alarm occurs, the alarm code and the totaled flow value are displayed alternately.

● Resetting the totaled flow count

The totaled flow value is reset to zero by holding down the [ENT] key for two seconds or more while the totaled flow value is displayed.

[!] Note (Advanced operation)

- Totalized flow event output function
When "1: Totalized flow rate count up ON" is selected as the event output type for function setup $\zeta - 07$ or $\zeta - 08$, the event output turns ON when the totaled flow value reaches the totaled flow event setting. This threshold value for the totaled flow event is set in the parameter setup mode.
- Totalized flow event automatic valve shut-off function
When "1: Function enabled" is set for the automatic valve shut-off function in function setup $\zeta - 13$, the valve will be automatically closed fully if the totaled flow value reaches the preset value. The threshold value for the totaled flow event is set in the parameter setup mode.

For details on function setup and parameter setup,

 Chapter 5. ADVANCED OPERATION

● Valve amperage display

If [DISP] key is pressed while the totalized flow is displayed, the PV, SP, L and L/min lamps go out, and the electrical current to the valve (0.0 to 100.0 [%]) is indicated on the 7-segment display.

Handling Precautions

- The valve amperage can vary greatly according to the differential pressure even at the same flow rate. The valve amperage alarm function cannot be used unless the differential pressure is stable.
- Even under stable differential pressure conditions, the relationship between the valve amperage and flow rate has hysteresis characteristics (amperage may vary even at the same flow rate).

When using the valve amperage alarm, be sure to test sufficiently under operating conditions. That way, an appropriate alarm current setting can be determined.

Note (Advanced operation)

- When "1: Only upper limit alarm used," "2: Only lower limit alarm used," or "3: Upper and lower limit alarm used" is selected for valve amperage alarm type (1 - 3 in the function setup), the valve amperage alarm will be activated if the valve current exceeds the upper limit set value or goes below the lower limit value. The valve amperage upper and lower limits are set in the parameter setup mode.

For details on function setup and parameter setup,  Chapter 5. ADVANCED OPERATION

4 - 2 Setting the Flow Rate

Set the flow rate as shown below.

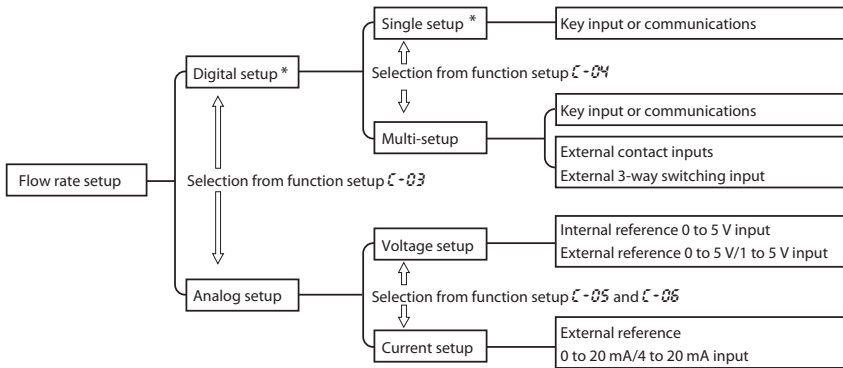

* Factory setting

Two kinds of setup methods, that is, digital and analog setup, are provided to set the flow rate. Additionally, the digital setup further provides two kinds of setup methods, single setup and multi-setup.

In single setup, the flow rate is set through key input or communications. In multi-setup, the flow rate is set through the key input, communications, external contact input, or external 3-way switching input. One flow set value can be set in the single setup while up to eight flow set values can be set in the multi-setup.

In the analog setup, the flow rate is set through the external voltage/current input.

The factory setting is digital setup.

Either digital setup or analog setup is selected as the flow rate setup method (ζ - 03 in the function setup).

0: Digital setup (flow rate is set through the key input or communication.)

1: Analog setup (flow rate is set through the external analog voltage/current.)

For further detailed setup, make selections in ζ - 04 to ζ - 06 in the function setup. For details on function setup,  Chapter 5. ADVANCED OPERATION

Handling Precautions

- Setup by communications is available only for models with RS-485 communications.

■ Digital flow rate setup

Up to eight SP values can be set on this device. The operating procedure may vary depending on the number of SP values to be set.

● Single setup (number of SPs in function setup ζ - 04 is 0)

Follow the procedure below to change the SP value:

- (1) Press the [DISP] key.
- >> The SP (flow rate setpoint) is shown on the 7-segment display
- (2) Change the SP value by pressing the [\blacktriangle] key or [\blacktriangledown] keys. You can move to the digit to be changed by pressing the [\blacktriangleleft] key.
- >> The digit currently being changed starts blinking.
- (3) When you have reached the target value, press the [ENT] key.
- >> The SP value is set, and saved.

Note (Advanced use, direct setup function)

- Control can be executed using an SP value currently being changed (indicated by blinking display) when the direct setup function is enabled for the instantaneous flow rate direct setup function ON/OFF (ζ - 24 in the function setup). In this case, the [ENT] key need not be pressed to enter the SP value.

Handling Precautions

- When switching the display by pressing the [DISP] key, first press the [ENT] key to enter the SP value, and switch the display.

For details on how to set up functions,  Chapter 5. ADVANCED OPERATION.

● Multi-setup (number of SPs in function setup ζ - 04 is 1 to 7)

In multi-setup, up to eight SP values can be switched by key operation and by external contact input.

Follow the procedure below to change the SP No. and SP value:

- (1) Press the [DISP] key.
- >> The display switches to SP No. $5P-0$ to $5P-7$ after about one second.
- (2) Press the [\blacktriangle] or [\blacktriangledown] keys to change the SP No. and press the [ENT] key.
- >> The SP No. is entered.
- (3) Change the SP value by pressing the [\blacktriangle] or [\blacktriangledown] keys. You can move to the digit to be changed by pressing the [\blacktriangleleft] key.
- >> The digit currently being changed blinks while the SP value is being changed.
- (4) When you have reached the target value, press the [ENT] key to enter the new SP value.
- >> The SP value and SP No. are updated, and the SP value of the selected SP No. is new the active SP.

 **Note (Advanced use, direct setup function)**

- Control can be executed using an SP No. or SP value currently being changed (indicated by blinking display) when the direct setup function is enabled for the instantaneous flow rate direct setup function ON/OFF (☑ - ☒ in the function setup). In this case, the [ENT] key need not be pressed to enter the SP value.

 **Handling Precautions**

- When switching the display by pressing the [DISP] key, first press the [ENT] key to enter the SP value. For details on how to set up functions,  Chapter 5. ADVANCED OPERATION.

 **Handling Precautions (Common to single setup and multi-setup)**

- When "1: Analog setup" is selected as the flow rate setup method (☑ - ☒ in the function setup) and the SP value is controlled by external voltage input, the SP value and SP No. cannot be changed with the [▲] or [▼] key.
- If no operation is made for approximately 10 s after the operation stated in (1) has been performed, the display automatically returns to the instantaneous flow rate display.
- If the [DISP] key is pressed during the operations in steps (2) and (3) (setting is blinking), the SP No. and SP value return to their previous values without saving of new values.
- When the SP value is updated in step (3) for single setup or in step (4) for multi-setup, the display automatically returns to the instantaneous flow rate display after approximately 2 s have elapsed.

■ Flow rate setup by external contact input (Advanced use)

When assigning "3: Switching of SP No." at external contact input function assignment $\xi - 1\xi$ to $\xi - 1\xi$ in the function setup, up to eight SP values can be changed by means of external contact ON and OFF combinations.

! Handling Precautions

- When changing the SP number by external contact input, the [▲] and [▼] keys cannot be used (but the SP value can be changed).
- (1) When the number of preset SP values is set to 5 to 8 in function setup $\xi - 0\xi$.
Assign "3: Switching of SP No." to all of $\xi - 1\xi$ to $\xi - 1\xi$ in the function setup.

	Input 3 (DI3)	Input 2(DI2)	Input 1(DI1)	Selected SP
External contact input state	OFF	OFF	OFF	SP-0
	OFF	OFF	ON	SP-1
	OFF	ON	OFF	SP-2
	OFF	ON	ON	SP-3
	ON	OFF	OFF	SP-4
	ON	OFF	ON	SP-5
	ON	ON	OFF	SP-6
	ON	ON	ON	SP-7

- (2) When the number of SP values is set to 3 or 4 in function setup $\xi - 0\xi$.
Assign "3: Switching of SP No." to two of $\xi - 1\xi$ to $\xi - 1\xi$ in the function setup.

	External contact input pair		Selected SP
	Input 2 (DI2)	Input 1 (DI1)	
	Input 3 (DI3)	Input 1 (DI1)	
	Input 3 (DI3)	Input 2 (DI2)	
External contact input state	OFF	OFF	SP-0
	OFF	ON	SP-1
	ON	OFF	SP-2
	ON	ON	SP-3

- (3) When the number of SP values is set to 2 in function setup $\xi - 0\xi$.
Assign "3: Switching of SP No." to one of $\xi - 1\xi$ to $\xi - 1\xi$ in the function setup.

	Input 1 to 3 (DI1 to DI3)	Selected SP
External contact input state	OFF	SP-0
	ON	SP-1

■ Flow rate setup by external 3-way switching input (Advanced use)

When "2: Switching of SP No." is assigned at external 3-way switching function $\zeta - \zeta^{\circ}$ in the function setup, three SP values ($\zeta^{\circ} - \zeta^{\circ}$ to $\zeta^{\circ} - \zeta^{\circ}$) can be changed with the external 3-way switching input as described in the table below.

External 3-way switching input state	Selected SP
OPEN	SP-0
0 V	SP-1
5 V	SP-2

! Handling Precautions

- When the SP No. is switched by the external 3-way switching input, you cannot switch the SP No. using [\blacktriangle] or [\blacktriangledown] keys, though you can switch the SP value.

■ Analog flow rate setup

The SP value (flow set value) can be changed by analog voltage by selecting analog setting as the flow rate setting method in function setup $\zeta - 03$. For details on how to set up the function,  Chapter 5. ADVANCED OPERATION.

The setup voltage/current range can be selected in the input range selection for analog setup ($\zeta - 05$ in the function setup).

The selection of voltage input/current input is linked automatically with the settings for analog output type and range selection ($\zeta - 05$ in the function setup). For example, when current output is selected as analog output type and range selection in $\zeta - 05$, the input type becomes current input type. Then, analog setup voltage/current for SP value can be calculated by the equations below.

Function setup $\zeta - 05$	Input voltage/current range	Setup voltage/current calculation
0	Internal reference 0 to 5 V*/ External reference 0 to 20 mA	Setup voltage [V] = Setting flow rate \div Full-scale flow rate \times Reference output voltage Setup current [mA] = Setting flow rate \div Full-scale flow rate \times 20
1	External reference 0 to 5 V/ External reference 0 to 20 mA	Setup voltage [V] = Setting flow rate \div Full-scale flow rate \times 5 Setup current [mA] = Setting flow rate \div Full-scale flow rate \times 20
2	External reference 1 to 5 V/ External reference 4 to 20 mA	Setup voltage [V] = Setting flow rate \div Full-scale flow rate \times 4 + 1 Setup current [mA] = Setting flow rate \div Full-scale flow rate \times 16 + 4

* Internal reference 0 to 5 V input means that the 5 V-reference voltage input of connector pin No. 20 of this controller is used and a voltage is input with the optional potentiometer (variable resistor with dial).

In this case, no external power supply for setup is needed. The reference voltage (5 V) is not accurate, so to actually measure and calculate the reference voltage output from this controller, use a voltage tester for the setup voltage calculation.

Note (Advanced use)

- When "1: Function enabled" is selected for analog scaling function $\zeta - 28$ in the function setup, the full scale flow rate can be changed to a desired level during analog setup. In this case, the full-scale flow rate of the analog flow rate output voltage/current (PV output voltage/current) is also changed as it is linked with the above flow rate. The scaling flow rate is set in the parameter setup mode. For details on how to set up functions,  Chapter 5. ADVANCED OPERATION.

4 - 3 Selecting the Operating Mode

■ Operating mode selection

Three kinds of valve operating modes are provided, "control mode," "fully closed mode," and "fully open mode." The factory setting is the control mode.

The operating mode can be forcibly changed to "fully closed mode" (valve is fully closed) or "fully open mode" (valve is fully open).

As shown in the diagram below, the mode is changed alternately between the control mode and fully closed mode every time the [RUN] key is pressed.

Additionally, to change the mode from the control mode to the fully open mode, keep the [RUN] key pressed for 2 seconds or longer.

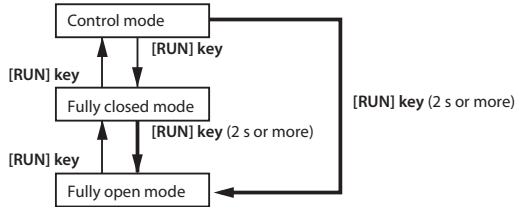

■ Operating mode display

The operating mode is shown on the 7-segment display during instantaneous flow rate display. Additionally, the OK lamp blinks in the fully open mode.

Operation mode	7-segment display	OK lamp	Remarks
Fully closed mode	0FF	Out	0FF is always displayed after checking that the flow rate is zero (0).
Control mode	0n	Out or lit	0n is displayed for approximately 1 second when the mode changes to the control mode.
Fully open mode	FULL	Blinking	FULL is displayed for approximately 1 second when the mode transits to the fully open mode.

! Handling Precautions

- When "0: [RUN] key disabled" is selected for "C - 02: [RUN] key operation and operating mode selection when power turned ON" in the function setup, the operating mode is not changed even though the [RUN] key is pressed.

- When "operating mode change (5, 6, or 8)" is selected for external contact input function assignment $\zeta - 1\text{①}$ to $\zeta - 1\text{②}$ in the function setup, changes by external contact take precedence over [RUN] key operation.

In the same manner, when "operating mode change (1 or 5)" is selected for external 3-way switching function $\zeta - 0\text{③}$ in the function setup, the

- The fully open mode cannot directly be changed to the control mode. To make the change, press the [RUN] key to change the fully open mode to the fully closed mode. After that, press the [RUN] key again to change the fully closed mode to the control mode.

 **Note (Advanced use, Selecting the operating mode through external input)**

- When "operating mode change (5, 6, or 8)" is selected for external contact input function assignment $\zeta - 1\text{①}$ to $\zeta - 1\text{②}$ in the function setup, the operating mode can be changed through external contact input.
- When "operating mode change (1, or 5)" is selected for external 3-way switching input function assignment $\zeta - 0\text{③}$ in the function setup, the operating mode can be changed through the external 3-way switching input.

For details on how to set up functions,  Chapter 5. ADVANCED OPERATION.

Chapter 5. ADVANCED OPERATION

The advanced operation provides three kinds of modes, "Function setup mode," "Parameter setup mode," and "Controller information display mode."

■ Setup mode transition operation

Normally, when the power is turned ON, the instantaneous flow rate is displayed in the basic operation mode.

When keys are operated as described in the diagram below during instantaneous flow rate display, the operation changes to the specified mode.

When the operating mode changes to "Function setup mode" or "Parameter setup mode," the specified setup can be changed.

In the "Device information display mode," you can check the statuses of major setup items (gas type, full scale flow rate, reference temperature, and communications address).

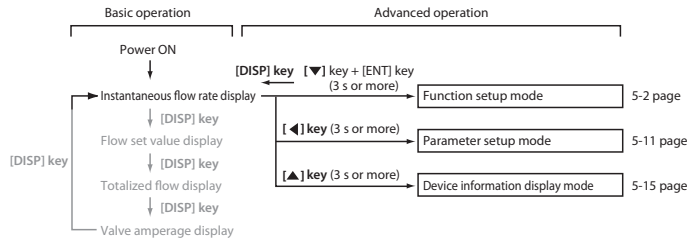

5 - 1 Functions

This section describes how to set up functions.

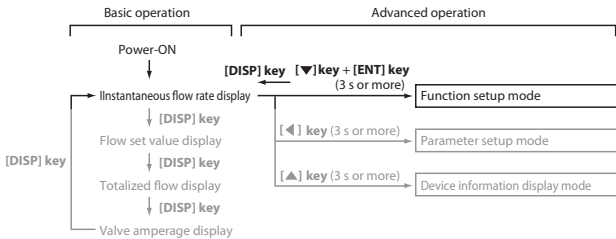

■ Setup method

Follow the procedure below to set functions such as event output type and external contact input assignments:



- (1) Press the [DISP] key several times to display the instantaneous flow rate.
 - >> The PV and L/min lamps light.
- (2) Hold down the and the [ENT] keys for three seconds or more.
 - >> Item $\zeta - \text{U} \text{!}$ is displayed on the 7-segment display and mode changes to the function setup mode.
- (3) Press the [▲] or [▼] key to select the desired setup item number, and then press the [ENT] key.
 - >> The current setting value blinks on the 7-segment display.
- (4) Press the [▲] or [▼] key to select the desired setting.
- (5) When you have selected the desired setting, press the [ENT] key to enter the setting.
 - >> The setting value is updated. (At this point, the setting value is saved.)
- (6) If you want to set up other items, return to step (3) and repeat the procedure.
 - Otherwise, proceed to step (7).
- (7) Press the [DISP] key.
 - >> The function setup mode changes to the instantaneous flow rate display.

! Handling Precautions



- If you do not press any keys for one minute after entering the function setup mode, the display automatically returns to the instantaneous flow rate display.
- If you press the [DISP] key without pressing the [ENT] key after carrying out the operation in step (4), the setting remains at the previous value without being updated.

■ Function setup items

The following table shows the function setup items:

Display item	Item Description	Setup Item and Description	Factory Setting	Remarks
$\zeta - 01$	Key lock	0: Key lock disabled 1: Settings other than flow rate setting (SP) are key-locked 2: All settings are key-locked	0	The key lock can be cancelled even while it is enabled. When an attempt is made to change a key-locked setting, $\zeta - 01$ is indicated on the display.
$\zeta - 02$	[RUN] key operation and operation mode selection when power turned ON	0: [RUN] key disabled (Operation starts in the control mode when the power is turned ON) 1: [RUN] key enabled (1) (Operation is started up in the operating mode used before power shut-down when the power is turned ON) 2: [RUN] key enabled (2) (Operation is started up in the fully closed mode when the power is turned ON)	1	Determines whether or not the operating mode is changed (fully closed/control/fully open) by the [RUN] key. Additionally, the operating mode at power ON can be selected. For how to select the operating mode:  4-3 Selecting the Operating Mode (P. 4-10).
$\zeta - 03^{*1}$	Flow rate setup method (SP setup method selection)	0: Digital setup (set by key operation or communications) 1: Analog setup (set by external analog input voltage)	0	
$\zeta - 04$	Number of flow set value (number of SPs selection)	0: Number of SPs = 1 ($SP - 0$ only) 1: Number of SPs = 2 ($SP - 0, SP - 1$) 2: Number of SPs = 3 ($SP - 0$ to $SP - 2$) 3: Number of SPs = 4 ($SP - 0$ to $SP - 3$) 4: Number of SPs = 5 ($SP - 0$ to $SP - 4$) 5: Number of SPs = 6 ($SP - 0$ to $SP - 5$) 6: Number of SPs = 7 ($SP - 0$ to $SP - 6$) 7: Number of SPs = 8 ($SP - 0$ to $SP - 7$)	0	How to switch the SP number using external contact input and external 3-way switching input:  Multi-setup (number of SPs in function setup C-04 is 1 to 7) (P. 4-5).
$\zeta - 05^{*2 *3}$	Input range selection of analog setup (analog SP input range selection)	(1) Analog output selection is set at voltage output ($\zeta - 05 = 0, 1, 4, \text{ or } 5$). 0: 0 to 5V internal reference input 1: 0 to 5V external reference input 2: 1 to 5V external reference input (2) Analog output selection is set at current output ($\zeta - 05 = 2, 3, 6, \text{ or } 7$) 0: 0 to 20 mA external reference input 1: 0 to 20 mA external reference input 2: 4 to 20 mA external reference input	1	Internal reference 0 to 5V input is the setting to use the 5V-reference voltage from this device when inputting a voltage with the optional potentiometer (variable change resistor with dial). Using this method, no external power supply for setup is needed. The voltage input/current input is automatically selected as it is linked with the set value of $\zeta - 05$:  Table in Note *2 (P. 5-9).

Display item	Item Description	Setup Item and Description	Factory Setting	Remarks
ζ-05 *2,*3	Analog output type and range selection	0: 0 to 5 V instantaneous flow rate output 1: 1 to 5 V instantaneous flow rate output 2: 0 to 20 mA instantaneous flow rate output 3: 4 to 20 mA instantaneous flow rate output 4: 0 to 5 V setting flow rate output 5: 1 to 5 V setting flow rate output 6: 0 to 20 mA setting flow rate output 7: 4 to 20 mA setting flow rate output	0	The scale can also be changed to the desired flow rate range. For details, see ζ-28 (Optional analog scaling function).
ζ-07	Event output 1 type assignment	0: Not used (OFF at all times) 1: ON when the totalized flow event occurs	0	The event output delay time is set in the parameter setup mode (see page 5-11). Note, however, that delay cannot be set for totalizer pulse output. 9: Events are output even in fully closed operation mode. 10: Events are not output in fully closed operation mode. -1 to -10: OFF at all times during power shutoff
ζ-08	Event output 2 type assignment	2: Totalized pulse output 3: ON when the flow rate is OK 4: ON in control mode 5: ON in fully open mode 6: ON in control or fully open mode 7: ON in fully closed mode 8: PV upper limit event 9: PV lower limit event 1 10: PV lower limit event 2 -1 to -10: Inverse output of above 1 to 10 (Normal operation: ON, Event occurrence: OFF)	0	
ζ-09	External 3-way switching function	0: Not used 1: Switching of operating mode 1 2: Switching of SP No. 3: Switching of totalizing operation 4: Switching of analog I/O voltage range (simultaneous external switching of ζ-05 and ζ-06) 5: Switching of operating mode 2	0	External inputs OPEN/GND/5 V are switched as shown below. For details on wiring, see page 3-10. 1: Control/fully closed/fully open 2: SP-0/SP-1/SP-2 3: Continue count/reset count/ stop count 4: See the table in note *3. 0 to 5 V/0 to 5 V/1 to 5 V 5: Fully closed/control/fully open

Display item	Item Description	Setup Item and Description	Factory Setting	Remarks
$\zeta - 10$	External contact 1 input function assignment (2-way switching)	0: Not used 1: Reset totalized flow count 2: Stop totalizing flow count 3: Switching of SP No.	0	3: For details on how to switch three or more SP Nos., see the description of the multi-setup (page 4-5).
$\zeta - 11$	External contact 2 input function assignment (2-way switching)	4: Switching of instantaneous flow rate setup method 5: Valve forced fully closed 6: Valve forced fully open	0	4: The $\zeta - 03$ (analog/digital) setting is shown when the contact is ON. 7: "Slow start ON" must be selected in $\zeta - 17$ (Slow start when the contact is ON). Similarly, in case of SP ramp control, "SP ramp control 1 or 2" must be selected in $\zeta - 27$. (Ramp control when the contact is ON.)
$\zeta - 12$	External contact 3 input function assignment (2-way switching)	7: Switching of slow start operation or switching of instantaneous SP ramp control operation 8: Switching of operating mode (control by contact ON, forced fully closed by contact OFF) 9: Flow rate zero adjustment 10: Switching of gas type setup 11: Switching of flow rate range 12: Switching of SP ramp 13: Alarm reset	0	5, 6, 8: If the forced fully closed and fully open are input from two sources at the same time, both inputs become invalid. 9: Set the operation mode to full close or set the flow rate to zero and perform the contact ON operation for a minimum of 10 seconds. See page 6-2 for the details. 10: $\zeta - 18$ becomes active by contact OFF and $\zeta - 28$ becomes active by contact ON. 11: $\zeta - 24$ becomes active by contact OFF and $\zeta - 25$ becomes active by contact ON. 12: Parameter setup ramp 1 is selected when the contact is OFF. Ramp 2 is selected when the contact is ON. 13: All alarm detections are cancelled while the contact ON is being continued.
$\zeta - 13$	Automatic valve shut-off when the totalized flow event occurs	0: Function disabled 1: Function enabled	0	When the totalized flow count reaches the totalized flow event setting, the valve is closed fully. This totalized flow event preset value can be set in the parameter setup mode.  5-2 Parameters (P. 5-11).
$\zeta - 14$	On/off of totalized flow reset function at start of control	0: Function disabled 1: Function enabled	0	When control is resumed from the fully closed operating mode, the totalized flow count is automatically reset.
$\zeta - 15$	Flow rate alarm setup type	0: Function disabled 1: Only upper limit alarm used 2: Only lower limit alarm used 3: Upper / lower limit alarm used	3	Set the alarm flow rate in the parameter setup mode.  5-2 Parameters (P. 5-11).

Display item	Item Description	Setup Item and Description	Factory Setting	Remarks
ξ - 16	Operation selection at alarm occurrence	0: Control continued and alarm output OFF any-time (alarm ignored) 1: Control continued and alarm output ON 2: Forced fully closed and alarm output ON 3: Forced fully open and alarm output ON -1: Control continued and alarm output ON -2: Forced fully closed and alarm output ON -3: Forced fully open and alarm output ON	1	Alarm code displays even if "0" is selected. -1 to -3: Output logic 1 to 3 is inverted (ON at all times). (However, they are turned OFF at all times during power shutoff.)
ξ - 17	Slow start setup	0: Slow start disabled 1 to 8: Slow start enabled (equivalent to approx. 1 to 6 seconds settling time)	0	Slow start is used when the external contact input turns ON when slow start operation switching is selected at ξ - 16 to ξ - 12.
ξ - 18	Gas type selection 1	0: Conversion factor for each gas type set by user 9: Hydrogen 10: Helium	9	If "0" is selected, a conversion factor (C.F.) must be entered in parameter setup mode. (☞ 5-2 Parameters (P. 5-11)). If "10: gas type changeover" is selected for the external contact input function assignment (ξ - 18 ξ - 11, or ξ - 12) and if the relevant contact is ON, the gas type is determined by the setting in ξ - 26 (gas type selection 2).
ξ - 19	Temperature at reference conditions	0: 20 °C, 101.325 kPa (1 atm) 1: 0 °C, 101.325 kPa (1 atm) 2: 25 °C, 101.325 kPa (1 atm) 3: 35 °C, 101.325 kPa (1 atm)	0	
ξ - 20	Valve amperage alarm setup	0: Valve amperage alarm disabled 1: Only upper limit alarm enabled 2: Only lower limit alarm enabled 3: Upper / lower limit alarm enabled	0	Set up the alarm current value in the parameter setup. (☞ 5-2 Parameters (P. 5-11)).
ξ - 21	Direct setup function ON/OFF	0: Function disabled 1: Function enabled	0	SP value being changed (flashing) is used for control.
ξ - 22	Control dead band setup	0: Function disabled 1: Function enabled	0	Valve operation stops while the control flow rate is within the OK judgment range. The OK judgment range can be set in the parameter setup mode. (☞ 5-2 Parameters (P. 5-11)).

Display item	Item Description	Setup Item and Description	Factory Setting	Remarks
ζ-23	PV filter (process for filtering of instantaneous flowrate)	0: Without filter 1: Two samplings moving average 2: Four samplings moving average 3: Eight samplings moving average	0	If the PV filter is used at a "2" or "3" setting, the operational differential pressure must be lower than the standard differential pressure. Do not change the setting while control is in progress.
ζ-24	Flow rate range setup 1	0: Standard range 10 to 99: 10% to 99% of standard range. (When calculating the range reduction, the value is cut off at the least significant digit.) -10 to -99: 10% to 99% of standard range. (When calculating the range reduction, the value is not cut off at the least significant digit.)	0	The setup and display resolution levels can be improved by reducing the flow rate range. ☞ 5-4 Flow Rate Range (P. 5-17). If a value of 10 to 99 is set, the value is cut off at the least significant digit when calculating the range reduction. Example: Standard range = 30.0 L/min. and range setup = 67 Calculation formula: 30.0 x 0.67 = 20.1 → Since the value is cut off at the least significant digit, the flow rate range becomes 20.0 L/min. The range selected by ζ-25 becomes active if "11" is selected for assignments ζ-10 to ζ-12 (external contact input function assignment) and only when the objective contact is turned ON. However, the range selected by ζ-24 becomes active otherwise.
ζ-25	Flow rate range setup 2		0	
ζ-26	Gas type selection 2	0: Conversion factor for each gas type set by user 9: Hydrogen 10: Helium	9	This setting determines the gas type when "10: gas type changeover" is selected for the external contact input function assignment (ζ-10, ζ-11, or ζ-12) and when the relevant contact is ON. For details, see the remarks for ζ-10, ζ-11, ζ-12 and ζ-18.

Display item	Item Description	Setup Item and Description	Factory Setting	Remarks
ℰ - 27	SP ramp control function	0: Function disabled 1: SP ramp control 1. (In SP ramp-up: ramp 1, in SP ramp-down: ramp 2) 2: SP ramp control 2. (In external contact OFF: ramp 1, in external contact ON: ramp 2)	0	The SP change ramp level (the rate of change per second) can be set to a constant value for control startup and setting flow rate changed. Setting of ramps 1 and 2 is done in parameter setup mode. ☞ 5-2 Parameters (P. 5-11). In case of SP ramp control 2, the operation is performed by ramp 2 when "12" is selected in either one of ℰ - 10 to ℰ - 12 (external contact input function assignment) and also when the target contact is ON, but otherwise operation is performed by ramp 1. If "7" is selected anywhere in ℰ - 10 to ℰ - 12, SP ramp control is performed only when the target contact is ON.
ℰ - 28	Analog scaling function	0: Function disabled 1: Function enabled	0	The flow rate at analog input / output 100% (5 V) can be optionally set. The flow rate is set in parameter setup mode. ☞ 5-2 Parameters (P. 5-11).
ℰ - 29	Forced PV (instantaneous flow rate) zero function	0: Function disabled 1: Function enabled	0	Instantaneous flow rate is made zero forcibly after the flow rate is set to zero or the mode is changed to valve forced fully closed mode and delay time has elapsed. Instantaneous flow rate variation in zero position caused by the inclination of pipe is neglected. Delay time is set in parameter setup mode. ☞ 5-2 Parameters (P. 5-11).
ℰ - 30*4	Communications address setting	0: Communications function disabled 1 to 127: Communications address	0	
ℰ - 31*4	Transfer speed selection	0: 38400 bps 1: 19200 bps 2: 9600 bps 3: 4800 bps 4: 2400 bps	1	
ℰ - 32*4	Data format selection	0: 8 data bits, even parity, 1 stop bit 1: 8 data bits, no parity, 2 stop bits	0	
ℰ - 35	SP limit function	0: SP limit function disabled 1: Only upper limit enabled 2: Only lower limit enabled 3: Upper and lower limits enabled	0	The upper and lower limit values of the flow rate setup range can be set to desired levels. Upper and lower limits are set in parameter setup mode. ☞ 5-2 Parameters (P. 5-11).

Display item	Item Description	Setup Item and Description	Factory Setting	Remarks
ζ - 36	Operating differential pressure setting for control optimization	0: Low differential pressure (50 ± 50 kPa) 1: Standard differential pressure (200 ± 100 kPa) 2: High differential pressure (300+0, -100 kPa)	1	When the setting corresponds to the actual operating differential pressure, control can be optimized. (When "0" is set, the control response speed becomes fast. When "2" is set, the control response speed becomes slow.)
ζ - 37*5	Flow rate display unit selection	0: Flow rate is displayed in the standard flow rate unit. 1: Flow rate is displayed in [L/min] at all times. -1: Flow rate is displayed in [mL/min] at all times.	0	0: When the flow rate range or gas type is changed, the unit is automatically changed to the display unit so that the range after change becomes the maximum resolution. 1: A value less than 0.001[L/min] is not displayed
ζ - 38	PV (instantaneous flow rate) display decimal point change function	0: Decimal point position is not changed 1: Decimal point position is shifted one digit left -1: Decimal point position is shifted one digit right	0	The decimal point position of the SP display is not changed. 1: When the standard decimal point position is the 4th digit (0.xxx), the function is invalid even though this setting is selected. If the flow rate exceeds the display range, a dash is displayed for all digits (----). -1: When the standard flow rate display does not have a decimal point, it is invalid even though this function is selected.

*1. When "4: flow rate setting method switching" is selected in the external contact inputs ζ - 40 to ζ - 42 in the function setup, switching according to external input takes precedence.

*2. According to the settings in ζ - 45 and ζ - 46, the analog input and output ranges are changed as shown in the table below.

Setting in ζ - 45	Settings in function setup ζ - 46		
	0	1	2
0	0 to 5 V internal reference input/ 0 to 5 V instantaneous flow rate output	0 to 5 V external reference input/ 0 to 5 V instantaneous flow rate output	1 to 5 V external reference input/ 0 to 5 V instantaneous flow rate output
1	0 to 5 V internal reference input/ 1 to 5 V instantaneous flow rate output	0 to 5 V external reference input/ 1 to 5 V instantaneous flow rate output	1 to 5 V external reference input/ 1 to 5 V instantaneous flow rate output
2	0 to 20 mA external reference input/ 0 to 20 mA instantaneous flow rate output	0 to 20 mA external reference input/ 0 to 20 mA instantaneous flow rate output	4 to 20 mA external reference input/ 0 to 20 mA instantaneous flow rate output
3	0 to 20 mA external reference input/ 4 to 20 mA instantaneous flow rate output	0 to 20 mA external reference input/ 4 to 20 mA instantaneous flow rate output	4 to 20 mA external reference input/ 4 to 20 mA instantaneous flow rate output
4	0 to 5 V internal reference input/ 0 to 5 V setting flow rate output	0 to 5 V external reference input/ 0 to 5 V setting flow rate output	1 to 5 V external reference input/ 1 to 5 V setting flow rate output
5	0 to 5 V internal reference input/ 1 to 5 V setting flow rate output	0 to 5 V external reference input/ 1 to 5 V setting flow rate output	1 to 5 V external reference input/ 1 to 5 V setting flow rate output
6	0 to 20 mA external reference input/ 0 to 20 mA setting flow rate output	0 to 20 mA external reference input/ 0 to 20 mA setting flow rate output	4 to 20 mA external reference input/ 0 to 20 mA setting flow rate output
7	0 to 20 mA external reference input/ 4 to 20 mA setting flow rate output	0 to 20 mA external reference input/ 4 to 20 mA setting flow rate output	4 to 20 mA external reference input/ 4 to 20 mA setting flow rate output

*3. When "4: Switching of analog I/O voltage range" is selected for external 3-way switching function assignment $\zeta - \text{B}9$ in the function setup, external 3-way switching input takes precedence over others. Additionally, the analog input and output ranges change as shown in the table below according to the input status and the setting status of $\zeta - \text{B}5$.

Setting in $\zeta - \text{B}5$	Status of external 3-way switching input		
	OPEN	0 V	5 V
0	0 to 5 V internal reference input/ 0 to 5 V instantaneous flow rate output	0 to 5 V external reference input/ 0 to 5 V instantaneous flow rate output	1 to 5 V internal reference input/ 1 to 5 V instantaneous flow rate output
1	0 to 20 mA external reference input/ 0 to 20 mA instantaneous flow rate output	0 to 20 mA external reference input/ 0 to 20 mA instantaneous flow rate output	4 to 20 mA external reference input/ 4 to 20 mA instantaneous flow rate output
2	0 to 5 V internal reference input/ 0 to 5 V setting flow rate output	0 to 5 V external reference input/ 0 to 5 V setting flow rate output	1 to 5 V internal reference input/ 1 to 5 V setting flow rate output
3	0 to 20 mA external reference input/ 0 to 20 mA setting flow rate output	0 to 20 mA external reference input/ 0 to 20 mA setting flow rate output	4 to 20 mA external reference input/ 4 to 20 mA setting flow rate output
4	0 to 5 V internal reference input/ 0 to 5 V instantaneous flow rate output	0 to 5 V external reference input/ 0 to 5 V instantaneous flow rate output	1 to 5 V internal reference input/ 1 to 5 V instantaneous flow rate output
5	0 to 20 mA external reference input/ 0 to 20 mA setting flow rate output	0 to 20 mA external reference input/ 0 to 20 mA setting flow rate output	4 to 20 mA external reference input/ 4 to 20 mA setting flow rate output
6	0 to 5 V internal reference input/ 0 to 5 V instantaneous flow rate output	0 to 5 V external reference input/ 0 to 5 V instantaneous flow rate output	1 to 5 V internal reference input/ 1 to 5 V instantaneous flow rate output
7	0 to 20 mA external reference input/ 0 to 20 mA setting flow rate output	0 to 20 mA external reference input/ 0 to 20 mA setting flow rate output	4 to 20 mA external reference input/ 4 to 20 mA setting flow rate output

*4. This setting can be made only for models with RS-485 communications.

*5. This function can be set only on the MQV9500 and MQV0005.

*6. The SP display on the main unit shows the final SP that was reached. This setting is also valid if $\zeta - \text{B}3$, "Flow rate setup method selection" is set to "1: Analog setup (by external analog input voltage)."

Handling Precautions

- When the operational differential pressure setting ($\zeta - \text{B}5$) is changed to "0: Low differential pressure (50 ± 50 kPa)," always use the device with an operational differential pressure less than 100 kPa. Failure to do so may cause overshoot or hunting of the flow rate.

5 - 2 Parameters

This section describes parameter setup.

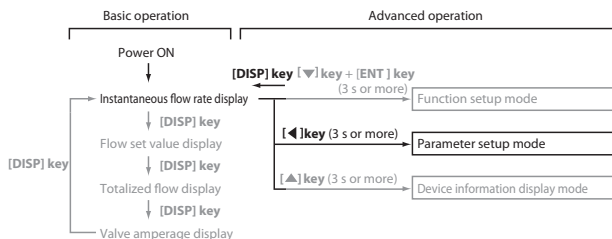

● Setup method

Follow the procedure below to set constants such as flow rate deviation alarm upper and lower limit setting values and event output delay times :

- (1) Press the [DISP] key several times to display the instantaneous flow rate.
 - >> The PV and L/min lamps light.
- (2) Hold down the [◀] key for three seconds or more.
 - >> Item No. 0.000 is displayed on the 7-segment display and the mode changes to the parameter setup mode.
- (3) Press the [▲] or [▼] key to select the desired setup item numbers, and press the [ENT] key.
 - >> The current setting blinks on the 7-segment display.
- (4) Press the [▲] or [▼] key to change the setting to the desired setting. You can move to the digit to be changed by pressing the [◀] key.
- (5) When you have finished changing the setting, press the [ENT] key to enter the setting.
 - >> At this point, the setting is updated.
- (6) If you want to set up other items, return to step (3) and repeat the procedure.
 - Otherwise, proceed to step (7).
- (7) Press the [DISP] key.
 - >> The mode return to the instantaneous flow rate mode from the parameter setup mode.

! Handling Precautions

- If you do not press any keys for one minute after entering the parameter setup mode, the display automatically returns to the regular (instantaneous flow rate) display.
- If you press the [DISP] key without pressing the [ENT] key after carrying out step (4), the setting remains at the previous value without being updated.

■ Parameter setup item list

No.	Display	Description	Factory Setting	Setting Range	Related Function Setup	Remarks
1	<i>R.RB</i> ^{*1}	Flow rate OK judgment range	2 % FS (0.02) *14	0.5 to 100% FS (0.005 to 1.00)*14	<i>ζ-07</i> <i>ζ-08</i>	Unit: L/min (standard)
2	<i>R.HYS</i> ^{*1}	Flow rate OK judgment hysteresis	1 % FS (0.01) *14	0.5 to 100% FS (0.005 to 1.00)*14	<i>ζ-22</i>	
3	<i>R.HI</i> ^{*2,*3}	Flow rate deviation upper limit alarm	10 % FS (0.10) *14	0.5 to 100% FS (0.005 to 1.00)*14	<i>ζ-15</i> <i>ζ-16</i>	
4	<i>R.H.HYS</i> ^{*2,*3}	Flow rate deviation upper limit alarm hysteresis	2 % FS (0.02) *14	0.5 to 100% FS (0.005 to 1.00)*14		
5	<i>R.Lo</i> ^{*2,*3}	Flow rate deviation lower limit alarm	10 % FS (0.10) *14	0.5 to 100% FS (0.005 to 1.00)*14		
6	<i>R.L.HYS</i> ^{*2,*3}	Flow rate deviation lower limit alarm hysteresis	2 % FS (0.02) *14	0.5 to 100% FS (0.005 to 1.00)*14		
7	<i>R.dLY</i> ^{*4}	Flow rate deviation alarm/valve amperage alarm judgment delay time	10.0 s	0.5 to 999.9 s <i>ζ-16</i> <i>ζ-20</i>	<i>ζ-15</i> <i>ζ-16</i> <i>ζ-20</i>	
8	<i>E.1.dL</i> ^{*5}	Event output 1 delay	0.0 s	0.0 to 999.9 s <i>ζ-08</i>	<i>ζ-07</i> <i>ζ-08</i>	Delay does not apply to totalizer pulse output.
9	<i>E.2.dL</i> ^{*5}	Event output 2 delay	0.0 s	0.0 to 999.9 s		
10	<i>ζ.F.</i> ^{*6}	User set gas type conversion factor	1.000	0.100 to 9.999 <i>ζ-26</i>	<i>ζ-18</i> <i>ζ-26</i>	
11	<i>R.I.HI</i> ^{*7}	Valve amperage upper limit alarm	100.0 %	0.1 to 100.0 % <i>ζ-20</i>	<i>ζ-16</i> <i>ζ-20</i>	At the factory setting, alarms are not detected.  Handling Precautions (P. 5-14).
12	<i>R.I.Lo</i> ^{*7}	Valve amperage lower limit alarm	0.0 %	0.0 to 99.9 %		
13	<i>E.1.SP</i> ^{*8}	Event output 1 upper/ lower limit flow rate setup	0% FS (0.0) *14	0 to 100 % FS (0.0 to 1.00) *14	<i>ζ-07</i> <i>ζ-08</i>	Unit: L/min (standard)
14	<i>E.2.SP</i> ^{*8}	Event output 2 upper/ lower limit flow rate setup	0% FS (0.0) *14	0 to 100 % FS (0.0 to 1.00) *14		
15	<i>r.RP.1</i> ^{*9}	SP ramp control slope 1	MQV9020/9050: 0.00	MQV9020/9050: 0.00 to 99.99	<i>ζ-27</i>	Sets the flow rate change per second. Flow rate unit: L/min (standard) (mL/min (standard) for the MQV9020/9050/9500) Ramp control does not function if the value stays at the factory setting (slope zero). (The SP takes effect immediately after a change.)
16	<i>r.RP.2</i> ^{*9}	SP ramp control slope 2	MQV9500: 0.0 MQV0005: 0.000 MQV0010/0050: 0.00 MQV0200: 0.0	MQV9500 : 0.0 to 999.9 MQV0005 : 0.000 to 9.999 MQV0010/0050 : 0.00 to 99.99 MQV0200: 0.0 to 999.9		

No.	Display	Description	Factory Setting	Setting Range	Related Function Setup	Remarks
17	R, S, C, L *10	Analog scaling	100 % FS (1.00) *14	10 to 100% FS (0.10 to 1.00) *14	└ - 28	Sets the flow rate corresponding to 100 % of analog input / output (5 V). Unit: L/min(standard)
18	E, R, L, o *11	Totalized flow event setting (last 4 digits)	0	0 to 9999	└ - 07 └ - 08 └ - 13	The unit (decimal point position) may vary depending on the model.
19	E, R, H, i *11	Totalized flow event setting (first 4 digits)	0	0 to 9999		☞ Flow rate totalization (P. 1-3).
20	P, O, d, L *12	PV forced zero function delay	3.0 s	0.0 to 999.9 s	└ - 29	
21	S, P, L, H *13	SP upper limit flow rate	100 % FS (1.00) *14	0 to 100 % FS (0.0 to 1.00) *14	└ - 35	Unit: L/min (standard)
22	S, P, L, L *13	SP lower limit flow rate	0 % FS (0.0) *14	0 to 100 % FS (0.0 to 1.00) *14		

*1. Operation during judgment of flow rate OK.

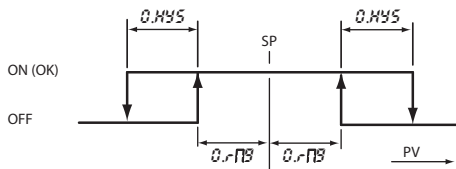

*2. Operation during judgment of flow rate deviation upper and lower limit alarms
Be sure to set so that $R, L, o \geq R, L, H, Y$ or $R, H, i \geq R, H, H, Y$.

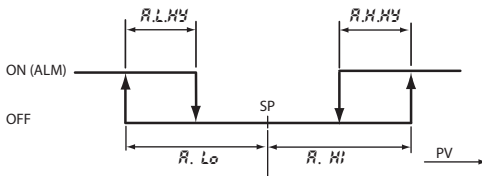

*3. Only items corresponding to the alarm type selected in flow rate alarm setup (└ - 15 in the function setup) can be set.

*4. These alarms can be set when (1 to 3) is set for flow rate alarm setup type (└ - 15) and valve amperage alarm setup type (└ - 09) in the function setup.

*5. This cannot be set when "0: Not used (OFF all times)" has been selected for └ - 07 and └ - 08 event output type assignment in the function setup.

*6. This can be set only when "0: Conversion factor for each gas type set by the user" has been selected for the └ - 18 or └ - 25 gas type selection 1 or 2 in the function setup.

*7. This can be set only if a suitable alarm type is selected in the └ - 20 valve amperage alarm setup (in the function setup).

-
- *8. This can be set only when "8 to 10: PV upper / lower limit event 1, 2" has been selected for the $\zeta - 07$ and $\zeta - 08$ event output type assignment in the function setup.
 - *9. This can be set only when "1 and 2: SP ramp control" has been selected for the $\zeta - 27$ SP ramp control function in the function setup.
 - *10. This can be set only when "1: Function enabled" has been selected for the $\zeta - 28$ analog optional scaling function in the function setup.
 - *11. This can be set only when "11: Cumulative flow event" has been selected as event output type in $\zeta - 07$ or $\zeta - 08$ in the function setup or when "1: Function enabled" has been selected for the automatic valve shut-off function upon occurrence of the cumulative flow event ($\zeta - 13$).
 - *12. This can be set only when "1: Function enabled" has been selected for the $\zeta - 29$ forced PV zero function in the function setup.
 - *13. This can be set only if suitable limit type is selected for the $\zeta - 35$ SP limit function in the function setup.
 - *14. The initial value and setting range are the full scale value multiplied by the ratio in parentheses. (The setting range differs according to model number and gas type.)

Handling Precautions

- The valve amperage changes greatly according to the differential pressure even if the flow rate is the same. For this reason, the valve amperage alarm function cannot be used under unstable differential pressure conditions.
- Even under stable differential pressure conditions, hysteresis characteristics (electric current to the valve differs even if the flow rate is the same) are applied to the relationship between the valve amperage and the flow rate. So, to use the valve amperage alarm function, first sufficiently test under operating conditions to check the valve amperage range, and then determine the alarm amperage setting.

5 - 3 Device Information Display

This section describes device information display.

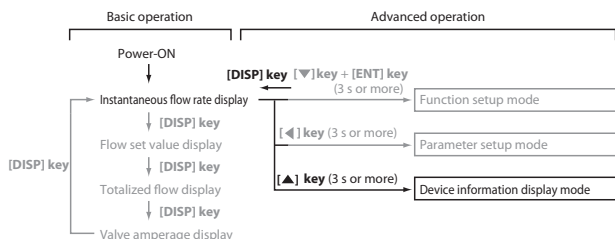

■ Setup method

Four items of those set on the device, that is, gas type, full-scale flow rate, reference temperature, and communications address* are displayed sequentially.

- (1) Press the [DISP] key several times to display the instantaneous flow rate.
 - >> The instantaneous flow rate is displayed and the PV and L/min lamps light.
- (2) Hold down the [▲] key for three seconds or more.
 - >> The \overline{RS} is displayed on the 7-segment display and the mode changes to the device information display mode.
- (3) Release the [▲] key once.
- (4) Press the [▲] or [▼] key to select the desired setting.
 - >> When releasing the key, the display item and currently set value are alternately displayed automatically.
- (5) If you want to set up other items, return to step (3) and repeat the procedure.
 - Otherwise, proceed to step (6).
- (6) Press the [DISP] key.
 - >> The mode returns to the instantaneous flow rate display mode.

*The communications address is displayed only on models with the RS-485 communications option.

! Handling Precautions

- If you do not press any keys for one minute after entering the device information display mode, the display automatically returns to the instantaneous flow rate display.

■ Device information display item

No.	Display Item	Description	Setting Range and Description	Related Function Setup	Remarks
1	gR5	Gas type	0 : Conversion factor for each gas type set by the user 9 : Hydrogen 10 : Helium	└- 18, └- 25	
2	F, SCL	Full-scale flow rate	(10 to 100 % of standard range)	└- 18, └- 24 └- 25, └- 25	Unit: L/min(standard)
3	S, dE9	Reference temperature	0 to 35	└- 19	Unit: °C
4	└, R05*	Communications address	0 to 127	└- 30	"0" means communications function disabled.

* Only for models with RS-485 communications.

5 - 4 Flow Rate Range

The flow rate range can be reduced to a level of 99% down to 10% of the standard range using the flow rate range setup (Ⓢ-24 or Ⓢ-25). However, the minimum control flow rate is the same as for the standard range. As the range is reduced, the setup and display resolution levels are improved as described in the table below.

Setup and display resolution levels after changing of range

MQV9020		MQV9050		MQV9500		MQV0005		MQV0010	
Full scale flow rate [mL/min]	Resolution [mL/min]	Full scale flow rate [mL/min]	Resolution [mL/min]	Full scale flow rate [L/min]	Resolution [L/min]	Full scale flow rate [L/min]	Resolution [L/min]	Full scale flow rate [L/min]	Resolution [L/min]
–	–	50.0–30.2	0.2	0.500–0.302	0.002	5.00–3.02	0.02	–	–
20.0–12.1	0.1	30.0–12.1	0.1	0.300–0.121	0.001	3.00–1.21	0.01	–	–
12.00–6.05	0.05	12.00–6.05	0.05	(120.0–60.5)	(0.5)	1.200–0.605	0.005	10.00–6.05	0.05
6.00–3.02	0.02	6.00–3.02	0.02	(60.0–30.2)	(0.2)	0.600–0.302	0.002	6.00–3.02	0.02
3.00–1.00	0.01	3.00–1.00	0.01	(30.0–10.0)	(0.1)	0.300–0.100	0.001	3.00–1.00	0.01

MQV0050		MQV0200	
Full scale flow rate [L/min]	Resolution [L/min]	Full scale flow rate [L/min]	Resolution [L/min]
50.0–30.2	0.2	–	–
30.0–12.1	0.1	200–121	1
12.0–6.05	0.05	120.0–60.5	0.5
6.00–3.02	0.02	60.0–30.2	0.2
3.00–1.00	0.01	30.0–10.0	0.1

Note: The display unit of the flow rate shown in () for the MQV9500 is mL/min.

! Handling Precautions

- Even after flow rate range is changed, the accuracy specifications are the same as for the standard range. (The full scale designated by % FS shows the numeric value of the standard range.)
- Even though the flow rate range is changed, the minimum control flow rate is the same as for the standard range.

■ Setup resolution in the analog setup

When "1: Analog setup" is selected in Ⓢ-03 (flow rate setup) and setup is done using an external analog voltage or analog current, a higher resolution can be set than in the digital setup.

Analog setup signal	Flow rate setup resolution
0 to 5 V or 0 to 20 mA	About 1/3700 of the full scale flow rate
1 to 5 V or 4 to 20 mA	About 1/3000 of the full scale flow rate

Example: Setting MQV0050 (50 L/min range) with an analog current of 4 to 20 mA
 Setup resolution ≠ 50 L/min ÷ 3000 ≠ 0.017 L/min (standard)

Chapter 6. TROUBLESHOOTING

■ Alarm code display

When a flow rate deviation alarm occurs or when an alarm occurs during selfdiagnostics, the device forcibly switches to the operating mode currently selected for “Operation selection at alarm occurrence” (ζ - 18 in the function setup).

Additionally, the alarm code and normal display are alternately shown at the upper 4- digit portion of the 7-segment display.

Alarm code	Problem	Causes	Remedy
R101	Flow rate deviation lower limit alarm	Insufficient alarm judgment delay/ power voltage/inlet pressure, excessive inlet pressure/operating temperature, etc.	If items under causes do not help, ask for repair.
R102	Flow rate deviation upper limit alarm	Insufficient alarm judgment delay, valve trouble, sensor trouble, etc.	Ask for repair if the delay is not a problem.
R111	Valve amperage lower limit alarm	Insufficient alarm judgment delay, alarm setting current value too high, excessive inlet pressure, etc.	Set parameter setup again.
R112	Valve amperage upper limit alarm	Insufficient alarm judgment delay, alarm setting current value too low, insufficient power voltage, insufficient inlet pressure, etc.	Set parameter setup again.
R181	Sensor error 1 (Heater voltage error)	Sensor trouble, foreign object on sensor, condensation on sensor, influx of hydrogen or helium gas, etc.	Remove the probable causes. If the device does not return to normal operation even after the power has been shutdown for a while, ask for repair.
R182	Sensor error 2 (Measured flow rate signal error)	Sensor trouble, foreign object on sensor, back current, etc.	
R183	Sensor error 3 (Sensor safety circuit activated)	Sensor failure, excessive flow rate, excessive operating temperature (etc.)	
R191	Calibration data error	Data corrupted due to electrical noise.	Ask for repair
R192	Sensor calibration data error	Data corrupted due to electrical noise.	Ask for repair
R193	User setting data error	Power shut-off during user setup data writing.	Set data again.

! Handling Precautions

- The alarm code is displayed only when the instantaneous flow rate or totalized flow is displayed.
- If a sensor error (R181 or R182) occurs, the flow rate measurement value will become indefinite. Therefore, the control flow rate becomes indefinite even if "0, 1, -1: Control continued" was selected for ζ - 18 in the function setup.

- When "2, -2: Forced fully closed" or "3, -3: Forced fully open" is selected for ξ - ξ in the function setup, the alarm display and operating mode at alarm occurrence are retained. To reset the alarm, perform the alarm reset operation.

● **Alarm reset operation**

When the [ENT] key is kept pressed continuously while the instantaneous flow rate is being displayed, the alarm is reset after 3 seconds have elapsed.

 **Handling Precautions**

- Perform flow rate zero adjustment with the actual flow rate stabilized to zero after completely replacing the inside of the flow path with the gas to be controlled.

 **Note**

- Flow rate zero adjustment can be performed by external contact input by selecting “flow rate zero adjustment” for $\zeta - 10$ to $\zeta - 12$ in the function setup. For details on how to set up functions,  Chapter 5. ADVANCED OPERATION.

Chapter 7. SPECIFICATIONS

■ MQV9020/9050

Item		Model No.	MQV9020	MQV9050
Valve type		Proportional solenoid valve		
Valve operation		Normally closed when de-energized (N.C.)		
Standard full-scale flow rate		*1	20.0 mL/min (standard)	50.0 mL/min (standard)
Gas types		Hydrogen (H ₂), Helium (He) Gas must be dry and not contain corrosive components (chlorine, sulfur, acid). The gas must also be clean, not containing dust or oil mist.		
Control	Range	1 to 100 % FS (see "Gas type and control range" table (page 7-8))		
	Valve output update cycle	5 ms		
	Response (at standard differential pressure)	Within 0.3 s at setting $\pm 2\%$ FS (typ.) (Control starts from the fully closed status or the setting is changed during control.)		
	Accuracy (at standard temperature and differential pressure, Q: flow rate)	(1) $\pm 1\%$ FS (50 % FS < Q \leq 100 % FS) (2) $\pm 0.5\%$ FS (0 % FS \leq Q \leq 50 % FS)	$\pm 1\%$ FS	
	Repeatability (Q: flow rate)	(1) $\pm 0.5\%$ FS (50 % FS < Q \leq 100 % FS) (2) $\pm 0.25\%$ FS (0 % FS \leq Q \leq 50 % FS)	$\pm 0.5\%$ FS	
	Temperature characteristics	0.06 % FS max. per 1°C		
Pressure characteristics	0.2 % FS max. per 100 kPa			
Pressure	Standard differential pressure	*2	100 kPa (Inlet pressure: 100 kPa (gauge), outlet pressure: 0 kPa (gauge))	
	Required differential pressure	*3	Hydrogen: 2.5 kPa Helium: 5 kPa	Hydrogen: 10 kPa Helium: 20 kPa
	Operating differential pressure range	*4	300 kPa max.	
	Pressure resistance (allowable inlet pressure)		1 MPa (gauge)	
Temperature	Standard operating temperature	*2	+23 °C	
	Allowable operating temperature range		-10 to +60 °C	
	Allowable storage temperature range		-20 to +70 °C	
Humidity	Allowable operating humidity range		10 to 90 % RH (condensation not allowed)	
External leaks	Helium leak rate		Within 1×10^{-6} Pa·m ³ /s	
Flow rate setup	Setup method		(1) Key operation (2) External analog input (3) MLP loader communications (4) RS-485 communications (3 wire-system)	
	Setup resolution		See "Gas type and control range" table (page 7-8).	
	External analog input		Input range: 0 to 5 V DC/1 to 5 V DC/0 to 20 mA/4 to 20 mA (switchable) Input impedance: 1 M Ω \pm 10% (for voltage input) 250 Ω \pm 10% (for current input)	

Chapter 7. SPECIFICATIONS

Model No.		MQV9020	MQV9050
Flow rate display	Display method	7-segment LED, 4 digits	
	Setup resolution	See "Gas type and control range" table (page 7-8).	
	Indication accuracy (at standard temperature and differential pressure; Q: flow rate)	(1) $\pm 1\%$ FS ± 1 digit (50% FS < Q \leq 100% FS) (2) $\pm 0.5\%$ FS ± 1 digit (0% FS \leq Q \leq 50% FS)	$\pm 1\%$ FS ± 1 digit
Totalizing function	Display range	0.0 to 99,999,999 mL	
	Display resolution	1 mL	
	Totalized count backup timing	(1) Every 200 mL (2) Every hour from the previous backup (3) At the time the RUN key is pressed.	(1) Every 500 mL
Analog output	Output type	Instantaneous flow rate (PV) output or setting flow rate (SP) output (switchable)	
	Output scale	0 to full-scale flow rate (scale can be changed)	
	Output range	0 to 5 V DC/1 to 5 V DC/0 to 20 mA/4 to 20 mA (switchable)	
	Max. output	7 V DC max./28 mA max. (max. output when flow rate exceeds the range)	
	Accuracy	Total output accuracy $\pm 0.3\%$ FS Indication accuracy $\pm 0.3\%$ FS	
	External resistance	Voltage output type: 250 k Ω min. Current output type: 300 Ω max.	
Alarm/event output	Number of outputs	Alarm output: 1, Event output: 2	
	Output rating	30 V DC, 30 mA max. (open collector non-insulated output)	
	Totalized pulse output width	100 ms $\pm 10\%$ (when pulse output is selected in the function setup)	
	Totalized pulse output rate	1 mL / 1 pulse	
External switching input	Input type, number of inputs	External 3-way switching input (OPEN/GND/5V): 1 External contact input (2-way switching): 3	
	Required circuit type	Non-voltage contact, or open collector	
	Contact OFF terminal voltage	External 3-way switching input: 2.5 ± 0.5 V External contact input: 2.8 ± 0.5 V	
	Contact ON terminal current	Approx. 0.5 mA (current flowing to contact)	
	Allowable ON contact resistance	250 Ω max.	
	Allowable OFF contact resistance	100 k Ω min.	
	Allowable ON residual voltage	1.0 V max. (open collector type)	
	Allowable OFF leakage current	50 μ A max. (open collector type)	
Reference voltage output	Output rating	5.0 V DC $\pm 5\%$, 5 mA max.	
	Application	Reference voltage of flow rate setting voltage and 5V input of external 3-way switching input	
Communications	Mode	(1) MLP loader communications (2) RS-485 communications (3-wire system)	*5 *6
	Transmission speed	2400, 4800, 9600, 19200, 38400 bps (only 19200 bps for loader communications)	
Power	Rating	24 V DC, current consumption: 300 mA max.	
	Allowable power voltage range	21.6 to 26.4 V (ripple 5% max.)	
	Isolation	The power circuit is isolated from the input/output circuit.	
Material of gas-contacting parts		SUS316, fluororesin, Fluororubber	
Connection method		1/4" Swagelok, 1/4" VCR	
Mounting orientation		Horizontal. Be sure that display surface does not face down.	
Mass		Approx. 1.2 kg	
Applicable standards		EN61326-2-3, EN61326-1 (To be used in an industrial electromagnetic environment) During EMC testing, the reading or output may fluctuate by the equivalent of $\pm 10\%$ FS.	

■ MQV9500/0005/0010

Item		Model No.	MQV9500	MQV0005	MQV0010
Valve type		Proportional solenoid valve			
Valve operation		Normally closed when de-energized (N.C.)			
Standard full-scale flow rate		*1	0.500 L/min (standard)	5.00 L/min (standard)	10.00 L/min (standard)
Gas types		Hydrogen (H ₂), Helium (He) Gas must be dry and not contain corrosive components (chlorine, sulfur, acid). The gas must also be clean, not containing dust or oil mist.			
Control	Range	1 to 100 % FS (see "Gas type and control range" table (page 7-8))			
	Valve output update cycle	5 ms			
	Response (at standard differential pressure)	Within 0.3 s at setting $\pm 2\%$ FS (typ.) (Control starts from the fully closed status or the setting is changed during control.)			
	Accuracy (at standard temperature and differential pressure, Q: flow rate)	(1) $\pm 2.0\%$ FS (80 % FS < Q \leq 100 % FS) (2) $\pm 1.0\%$ FS (40 % FS < Q \leq 80 % FS) (3) $\pm 0.5\%$ FS (0 % FS \leq Q \leq 40 % FS)			
	Repeatability (Q: flow rate)	(1) $\pm 0.5\%$ FS (40 % FS < Q \leq 100 % FS) (2) $\pm 0.25\%$ FS (0 % FS \leq Q \leq 40 % FS)			
	Temperature characteristics	0.06 % FS max. per 1°C			
Pressure characteristics		0.2 % FS max. per 100 kPa			
Pressure	Standard differential pressure	*2	200 kPa (Inlet pressure: 200 kPa (gauge), outlet pressure: 0 kPa (gauge))		
	Required differential pressure	*3	Hydrogen: 20 kPa Helium: 40 kPa	Hydrogen: 80 kPa Helium: 150 kPa	
	Operating differential pressure range	*4	300 kPa max.		
	Pressure resistance (allowable inlet pressure)	1 MPa (gauge)			
Temperature	Standard operating temperature	*2	+23 °C		
	Allowable operating temperature range	-10 to +60 °C			
	Allowable storage temperature range	-20 to +70 °C			
Humidity	Allowable operating humidity range	10 to 90 % RH (condensation not allowed)			
External leaks	Helium leak rate	Within 1×10^{-6} Pa·m ³ /s			
Flow rate setup	Setup method	(1) Key operation (2) External analog input (3) MLP loader communications (4) RS-485 communications (3 wire-system)			
	Setup resolution	See "Gas type and control range" table (page 7-8).			
	External analog input	Input range: 0 to 5 V DC/1 to 5 V DC/0 to 20 mA/4 to 20 mA (switchable) Input impedance: 1 M Ω \pm 10% (for voltage input) 250 Ω \pm 10% (for current input)			

Chapter 7. SPECIFICATIONS



Model No.		MQV9500	MQV0005	MQV0010
Flow rate display	Display method	7-segment LED, 4 digits		
	Setup resolution	See "Gas type and control range" table (page 7-8).		
Totalizing function	Indication accuracy (at standard temperature and differential pressure; Q: flow rate)	(1) $\pm 2\%$ FS ± 1 digit (80 % FS < Q \leq 100 % FS) (2) $\pm 1\%$ FS ± 1 digit (40 % FS < Q \leq 80 % FS) (3) $\pm 0.5\%$ FS ± 1 digit (0 % FS \leq Q \leq 40 % FS)		
	Display range	0.00 to 999,999.99 L	0.0 to 9,999,999.9 L	0.0 to 99,999,999 L
	Display resolution	0.01 L	0.1 L	1 L
Analog output	Totalized count backup timing	(1) Every 5 L (2) Every hour from the previous backup (3) At the time the RUN key is pressed.	(1) Every 50 L	(1) Every 100 L
	Output type	Instantaneous flow rate (PV) output or setting flow rate (SP) output (switchable)		
	Output scale	0 to full-scale flow rate (scale can be changed)		
	Output range	0 to 5 V DC/1 to 5 V DC/0 to 20 mA/4 to 20 mA (switchable)		
	Max. output	7 V DC max./28 mA max. (max. output when flow rate exceeds the range)		
Alarm/event output	Accuracy	Total output accuracy $\pm 0.3\%$ FS Indication accuracy $\pm 0.3\%$ FS		
	External resistance	Voltage output type: 250 k Ω min. Current output type: 300 Ω max.		
External switching input	Number of outputs	Alarm output: 1, Event output: 2		
	Output rating	30 V DC, 30 mA max. (open collector non-insulated output)		
	Totalized pulse output width	100 ms $\pm 10\%$ (when pulse output is selected in the function setup)		
	Totalized pulse output rate	0.01 L/1 pulse	0.1 L/1 pulse	1 L/1 pulse
Reference voltage output	Input type, number of inputs	External 3-way switching input (OPEN/GND/5V): 1 External contact input (2-way switching): 3		
	Required circuit type	Non-voltage contact, or open collector		
	Contact OFF terminal voltage	External 3-way switching input: 2.5 ± 0.5 V External contact input: 2.8 ± 0.5 V		
	Contact ON terminal current	Approx. 0.5 mA (current flowing to contact)		
	Allowable ON contact resistance	250 Ω max.		
	Allowable OFF contact resistance	100 k Ω min.		
	Allowable ON residual voltage	1.0 V max. (open collector type)		
	Allowable OFF leakage current	50 μ A max. (open collector type)		
Communications	Output rating	5.0 V DC $\pm 5\%$, 5 mA max.		
	Application	Reference voltage of flow rate setting voltage and 5V input of external 3-way switching input		
Power	Mode	(1) MLP loader communications ^{*5} (2) RS-485 communications (3-wire system) ^{*6}		
	Transmission speed	2400, 4800, 9600, 19200, 38400 bps (only 19200 bps for loader communications)		
Material of gas-contacting parts	Rating	24 V DC, current consumption: 300 mA max.		
	Allowable power voltage range	21.6 to 26.4 V (ripple 5 % max.)		
	Isolation	The power circuit is isolated from the input/output circuit.		
Connection method	SUS316, fluororesin, Fluororubber			
Mounting orientation	9/16-18UNF, Rc 1/4", 1/4" Swagelok, 1/4" VCR			
Mass	Horizontal. Be sure that display surface does not face down.			
Applicable standards	Approx. 1.2 kg			
	EN61326-2-3, EN61326-1 (To be used in an industrial electromagnetic environment) During EMC testing, the reading or output may fluctuate by the equivalent of $\pm 10\%$ FS.			

■ MQV0050/0200

Item		Model No.	MQV0050	MQV0200
Valve type		Proportional solenoid valve		
Valve operation		Normally closed when de-energized (N.C.)		
Standard full-scale flow rate		50.0 L/min (standard)	200 L/min (standard)	
Gas types		Hydrogen (H ₂), Helium (He) Gas must be dry and not contain corrosive components (chlorine, sulfur, acid). The gas must also be clean, not containing dust or oil mist.		
Control	Range	1 to 100 % FS (see "Gas type and control range" table (page 7-8))		
	Valve output update cycle	5 ms		
	Response (at standard differential pressure)	Within 0.3 s at setting ± 2 % FS (typ.) (Control starts from the fully closed status or the setting is changed during control.)		
	Accuracy (at standard temperature and differential pressure, Q: flow rate)	(1) ± 2 % FS (80 % FS < Q \leq 100 % FS) (2) ± 1 % FS (40 % FS < Q \leq 80 % FS) (3) ± 0.5 % FS (0 % FS \leq Q \leq 40 % FS)		
	Repeatability (Q: flow rate)	(1) ± 0.5 % FS (40 % FS < Q \leq 100 % FS) (2) ± 0.25 % FS (0 % FS \leq Q \leq 40 % FS)		
	Temperature characteristics	0.06 % FS max. per 1°C		
Pressure characteristics	0.2 % FS max. per 100 kPa			
Pressure	Standard differential pressure	200 kPa (Inlet pressure: 200 kPa (gauge), outlet pressure: 0 kPa (gauge))		
	Required differential pressure	Hydrogen: 20 kPa Helium: 40 kPa	Hydrogen: 100 kPa Helium: 180 kPa	
	Operating differential pressure range	300 kPa max.		
	Pressure resistance (allowable inlet pressure)	1 MPa (gauge)		
Temperature	Standard operating temperature	+23 °C		
	Allowable operating temperature range	-10 to +60 °C		
	Allowable storage temperature range	-20 to +70 °C		
Humidity	Allowable operating humidity range	10 to 90 % RH (condensation not allowed)		
External leaks	Helium leak rate	Within 1 x 10 ⁻⁶ Pa·m ³ /s		
Flow rate setup	Setup method	(1) Key operation (2) External analog input (3) MLP loader communications (4) RS-485 communications (3 wire-system)		
	Setup resolution	See "Gas type and control range" table (page 7-8).		
	External analog input	Input range: 0 to 5 V DC/1 to 5 V DC/0 to 20 mA/4 to 20 mA (switchable) Input impedance: 1 M Ω \pm 10 % (for voltage input) 250 Ω \pm 10 % (for current input)		
Flow rate display	Display method	7-segment LED 4 digits		
	Setup resolution	See "Gas type and control range" table (page 7-8).		
	Indication accuracy (at standard temperature and differential pressure; Q: flow rate)	(1) ± 2 % FS ± 1 digit (80 % FS < Q \leq 100 % FS) (2) ± 1 % FS ± 1 digit (40 % FS < Q \leq 80 % FS) (3) ± 0.5 % FS ± 1 digit (0 % FS \leq Q \leq 40 % FS)		

Chapter 7. SPECIFICATIONS

Model No.		MQV0050	MQV0200
Totalizing function	Display range	0 to 99,999,999 L	0.01 to 999,999.99 m ³
	Display resolution	1 L	0.01m ³
	Totalized count backup timing	(1) Every 500 L	(1) Every 2 m ³
		(2) Every hour from the previous backup (3) At the time the RUN key is pressed.	
Analog output	Output type	Instantaneous flow rate (PV) output or setting flow rate (SP) output (switchable)	
	Output scale	0 to full-scale flow rate (scale can be changed.)	
	Output range	0 to 5 V DC/1 to 5 V DC/0 to 20 mA/4 to 20 mA (switchable)	
	Max. output	7 V DC max./28 mA max. (max. output when flow rate exceeds range)	
	Accuracy	Total output accuracy ±0.3% FS Indication accuracy ±0.3 % FS	
	External load resistance	Voltage output type: 250 kΩ min. Current output type: 300 Ω max.	
Alarm/event output	Number of outputs	Alarm output: 1, Event output: 2	
	Output rating	30 V DC, 30 mA max. (open collector non-insulated output)	
	Totalized pulse output width	100 ms ±10 % (when pulse output is selected in the function setup)	
	Totalized pulse output rate	1 L /1 pulse	0.01 m ³ /1 pulse
External switching input	Input type, number of inputs	External 3-way switching input (OPEN/GND/5V): 1 External contact input (2-way switching): 3	
	Required circuit type	Non-voltage contact, or open collector	
	Contact OFF terminal voltage	External 3-way switching input: 2.5 ±0.5 V External contact input: 2.8 ±0.5 V	
	Contact ON terminal current	Approx. 0.5 mA (current flowing to contact)	
	Allowable ON contact resistance	250 Ω max.	
	Allowable OFF contact resistance	100 kΩ min.	
	Allowable ON residual voltage	1.0 V max. (open collector type)	
	Allowable OFF leakage current	50 μA max. (open collector type)	
Reference voltage output	Output rating	5.0 V DC ±5 %, 5 mA max.	
	Application	Reference voltage of flow rate setting voltage and 5 V input of external 3-way switching input	
Communications	Mode	(1) MLP loader communications *5 (2) RS-485 communications (3-wire system) *6	
	Transmission speed	2400, 4800, 9600, 19200, 38400 bps (only 19200 bps for loader communications)	
Power	Rating	24 V DC, current consumption: 300 mA max.	
	Allowable power voltage range	21.6 to 26.4 V (ripple 5 % max.)	
	Isolation	The power circuit is isolated from the input/output circuit.	
Material of gas-contacting parts		SUS316, Teflon, Fluororubber	
Connection method		9/16-18UNF, Rc 1/4", 1/4" Swagelok, 1/4" VCR	
Mounting orientation		Horizontal. Be sure that display surface does not face down.	
Mass		Approx. 1.2 kg	
Applicable standards		EN61326-2-3, EN61326-1 (To be used in an industrial electromagnetic environment) During EMC testing, the reading or output may fluctuate by the equivalent of ±10%FS.	

- *1. The notations L/min (standard) refer to volumetric flow rate per minute after conversion to 20°C, 1 atmosphere. The reference temperature can also be changed to 0°C, 25°C or 35°C in the $\text{L} \cdot \text{min}^{-1}$ flow rate display unit selection. For details about the controllable range for each gas type, see the section on  Gas type and control range (P. 7-8)
- *2. This item shows the temperature and pressure during calibration.
- *3. Differential pressure required for obtaining full-scale flow rate. (Outlet pressure=0.0 kPa (gauge))
- *4. Operation is possible even below the required differential pressure, but the controllable flow rate range becomes narrower.  Relationship between differential pressure and flow rate (For Hydrogen) (P. 7-9)
- *5. The MLP100A100 loader package (sold separately) is needed.
- *6. Only models with RS-485 communications option.

■ Korea Certification Mark



이 기기는 업무용(A급) 전자파 적합기기로서 판매자 또는 사용자는 이점을 주의하시기 바라며, 가정외의 지역에서 사용하는 것을 목적으로 합니다.

■ Gas type and control range

The controllable flow rate range may vary depending on the type of gas.
For details, see the tables below.

Model No. Gas type	MQV9020		MQV9050		MQV9500	
	Control flow rate range mL/min (standard)	Setup/display resolution mL/min (standard)	Control flow rate range mL/min (standard)	Setup/display resolution mL/min (standard)	Control flow rate range L/min (standard)	Setup/display resolution L/min (standard)
Hydrogen	0.2 to 20.0	0.1	0.4 to 50.0	0.2	0.004 to 0.500	0.002
Helium	0.2 to 20.0	0.1	0.4 to 50.0	0.2	0.004 to 0.500	0.002

Model No. Gas type	MQV0005		MQV0010		MQV0050	
	Control flow rate range L/min (standard)	Setup/display resolution L/min (standard)	Control flow rate range L/min (standard)	Setup/display resolution L/min (standard)	Control flow rate range L/min (standard)	Setup/display resolution L/min (standard)
Hydrogen	0.04 to 5.00	0.02	0.10 to 10.00	0.05	0.4 to 50.0	0.2
Helium	0.04 to 5.00	0.02	0.10 to 10.00	0.05	0.4 to 50.0	0.2

Model No. Gas type	MQV0200	
	Control flow rate range L/min (standard)	Setup/display resolution L/min (standard)
Hydrogen	2 to 200	1
Helium	2 to 200	1

Note

- The setup and display resolutions described above can be improved by reducing the flow rate range using flow rate range setup $\zeta - 24$ or $\zeta - 25$.
A still higher resolution can be set using the analog setup ($\zeta - 03$, #1). For more information, see section 5-4, "Flow Rate Range Change Function and Settings and Display Resolutions After Change of Range" (page 5-17).

■ China RoHS

基于SJ/T11364-2014「电子电气产品有害物质限制使用标识要求」的表示式样
产品中有害物质的名称及含量

部件名称	有害物质					
	铅 (Pb)	汞 (Hg)	镉 (Cd)	六价铬 (Cr(VI))	多溴联苯 (PBB)	多溴二苯醚 (PBDE)
电路板	×	○	○	○	○	○
流路部件 (流路中与气体接触的部件)	×	○	○	○	○	○
本表格依据SJ/T 11364 的规定编制。 ○：表示该有害物质在该部件所有均质材料中的含量均在GB/T 26572规定的限量要求以下。 ×：表示该有害物质至少在该部件的某一均质材料中的含量超出GB/T 26572规定的限量要求。						



■ Relationship between differential pressure and flow rate (For Hydrogen)

Condition : the valve is fully open in air.

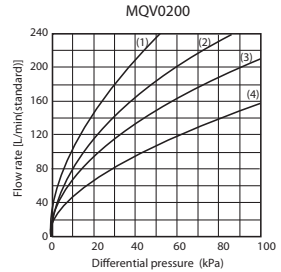
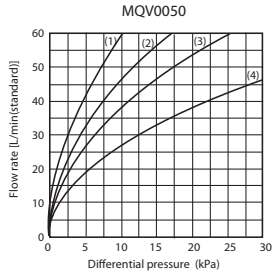
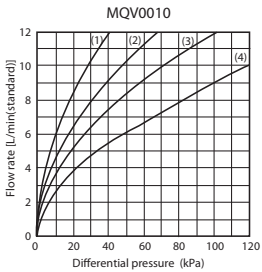
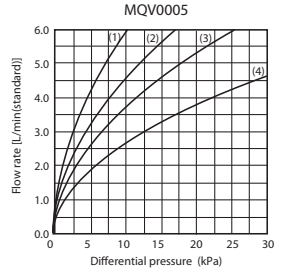
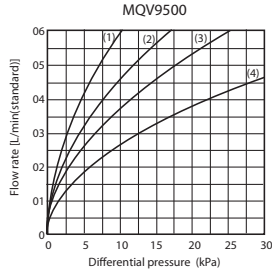
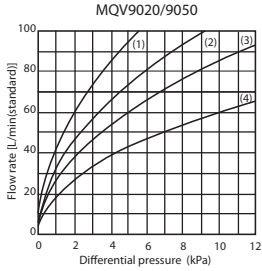

Outlet pressure condition

- (1) 150kPa(gauge)
- (2) 50kPa(gauge)
- (3) 0kPa(gauge)
- (4) -50kPa(gauge)

■ Relationship between differential pressure and flow rate (For Helium)

Condition : the valve is fully open in air.

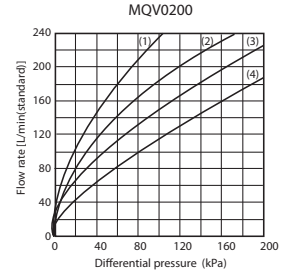
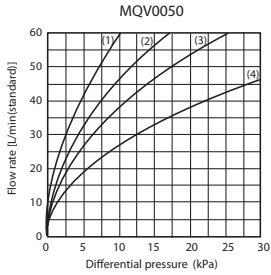
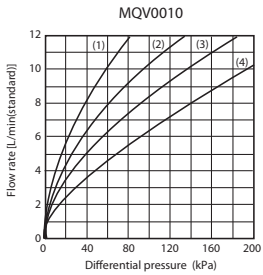
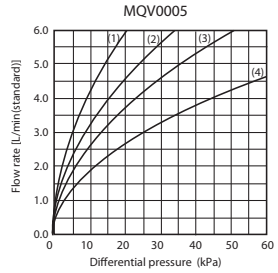
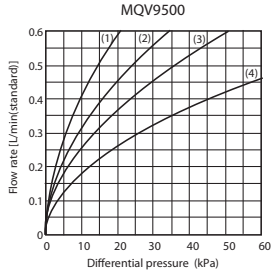
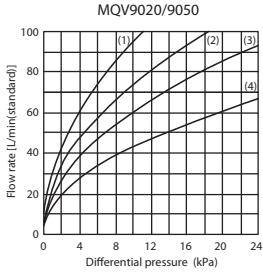

Outlet pressure condition

- (1) 150 kPa(gauge)
- (2) 50 kPa(gauge)
- (3) 0 kPa(gauge)
- (4) -50 kPa(gauge)

! Handling Precautions

- If the outlet pressure is different from the values graphed on the previous page, calculate the flow rate using the appropriate equation below.

(1) When $P2 / P1 > 0.53$,

$$Q = C1 \sqrt{(P1 - P2) P2}$$

(2) When $P2 / P1 \leq 0.53$,

$$Q = C2 \cdot P1$$

P1: Inlet absolute pressure [kPa (abs)]

P2: Outlet absolute pressure [kPa (abs)]

(Absolute pressure = gauge pressure + 101.3 kPa)

Q: Flow rate [L/min (standard)], [(mL/min) (standard) for MQV9020/9050]

C1 and C2: Constant values by model

(Hydrogen)

MQV9020: C1=2.684, C2=1.340

MQV9050: C1=2.684, C2=1.340

MQV9500: C1=0.01181, C2=0.00590

MQV0005: C1=0.1181, C2=0.0590

MQV0010: C1=0.1181, C2=0.0590

MQV0050: C1=1.181, C2=0.590

MQV0200: C1=2.091, C2=1.044

(Helium)

MQV9020: C1=1.904, C2=0.950

MQV9050: C1=1.904, C2=0.950

MQV9500: C1=0.00838, C2=0.00418

MQV0005: C1=0.0838, C2=0.0418

MQV0010: C1=0.0838, C2=0.0418

MQV0050: C1=0.838, C2=0.418

MQV0200: C1=1.483, C2=0.740

Ex.: For the MQV0200, gas type is hydrogen, inlet pressure is 100kPa (gauge), and outlet pressure is 80 kPa (gauge).

$$P1=201.3 \text{ kPa(absolute)}, P2=181.3 \text{ kPa(absolute)} \rightarrow P2/P1=0.901$$

$$Q = 2.091 \times \sqrt{(201.3 - 181.3) \times 181.3}$$

$$= 126 \text{ [L/min(standard)]}$$

■ Optional parts (sold separately)

Item	Model No.	Remarks
Cable with dedicated connector	81446681-001	20-wire flat cable 2 m (AWG#24)
AC adapter	81446951-001	20-wire shielded cable 5 m (7/0.2 mm ²)
Potentiometer for flow rate setting	81446957-001	Input rating: 100 to 240 V AC 50/60 Hz 0.4 A Output rating: 24 V DC/750 mA Operating temperature range: 0 to 40 °C
Front cover for separate display unit	81446683-002 81446858-001	5 kΩ with digital dial, 10 turns Mask: 1 piece Plate: 1 piece Mounting screws: 2 pieces
Loader Package	MLP100A100	MQV can be configured on a PC. In addition, operating status such as flow rate trends can be monitored on the PC screen.
Rc 1/4" joint	81446834-001	Set of 2 pieces, O-ring attached, oil-inhibited product
1/4" Swagelok	81446833-001	Set of 2 pieces, O-ring attached, oil-inhibited product
1/4" VCR	81446895-001	Set of 2 pieces, O-ring attached, oil-inhibited product

! Handling Precautions

- The old type AC adapter, 81446682-001, (15 V DC, 350 mA) cannot be used for this device.

■ External dimensions

● Models with integrated display

MQV9020B/9050B/9500B/0005B/0010B/0050B/0200B

(For MQV9020B/9050B, only 1/4 Swagelok and 1/4 VCR connections apply)

Unit: mm

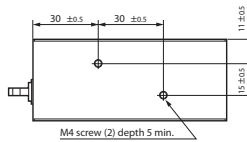
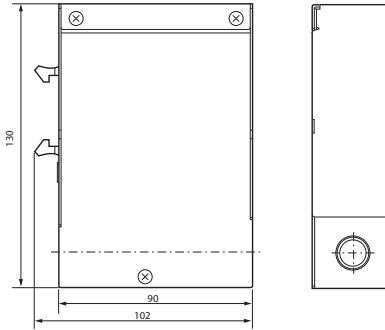
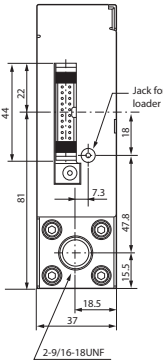
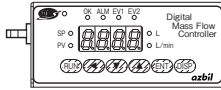

9/16-18UNF connection type

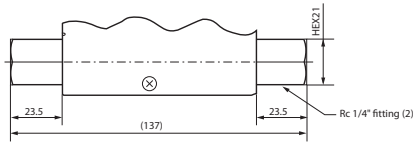

Rc 1/4" connection type

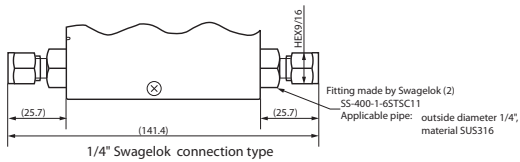

1/4" Swagelok connection type

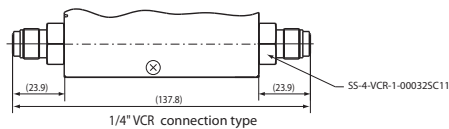

1/4" VCR connection type

● **Model with separate display**
MQV9020C/9050C/9500C/0005C/0010C/0050C/0200C
(For MQV9020C/9050C, only 1/4 Swagelok and 1/4 VCR connections apply)

● **Body**

Unit: mm

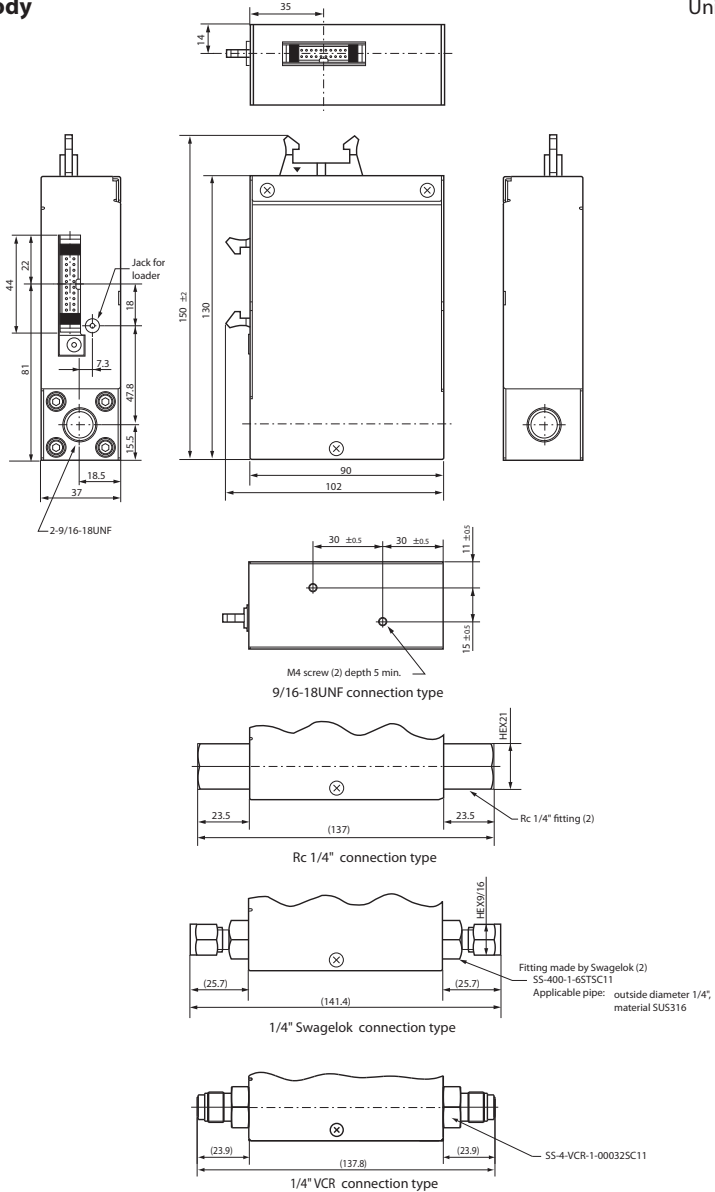

● Separate display unit

Unit: mm

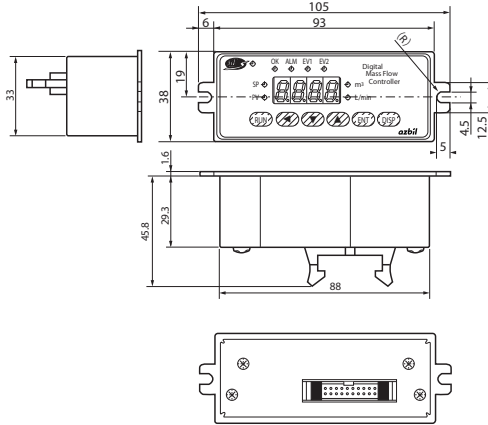

Mounting panel cutout dimensions (recommended)

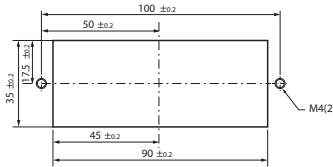

● Cable for connecting display to body

Unit: mm

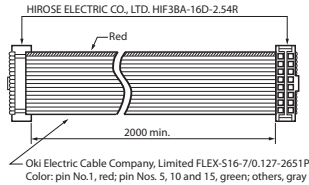

● **Front cover for separate display unit 81446858-001**

Unit: mm

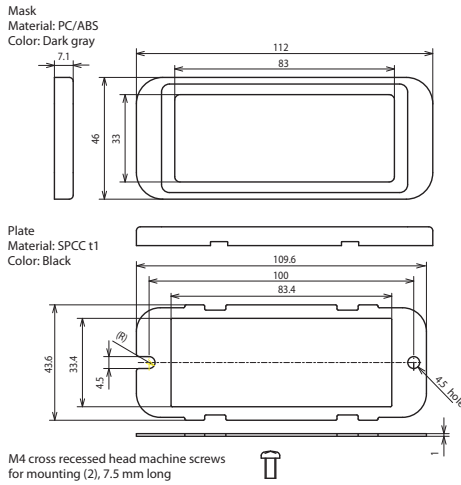

● **Cable with dedicated connector**

● **20-wire flat cable 81446681-001**

Unit: mm

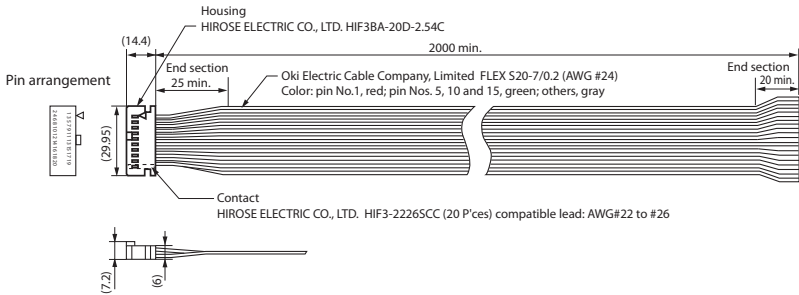

● **20-wire shielded cable 81446951-001**

Pin No.
-lead wire color correspondence table

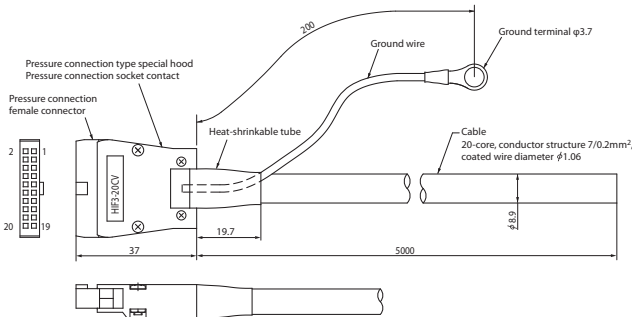

Pin No.	Lead wire
1	Black
2	Black/White
3	Red
4	Red/White
5	Green
6	Green/White
7	Yellow
8	Yellow/White
9	Brown
10	Brown/White
11	Blue
12	Blue/White
13	Grey
14	Grey/White
15	Orange
16	Orange/White
17	Purple
18	Purple/White
19	Bright Green
20	Bright Green/White

● Potentiometer for flow rate setting 81446683-002

● Digital dial

● Potentiometer

Unit: mm

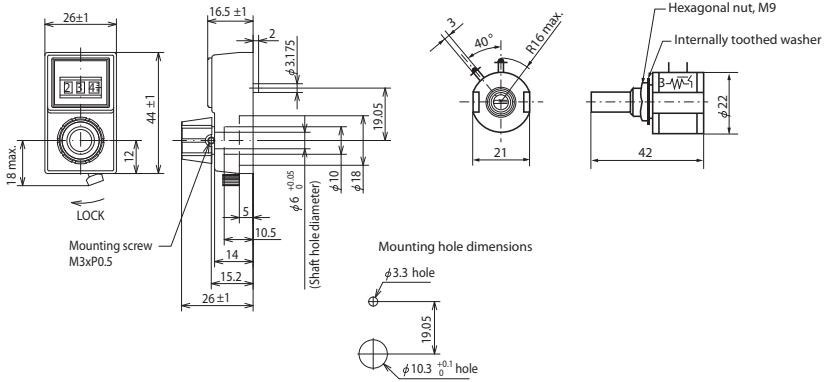

● AC adapter 81446957-001

Unit: mm

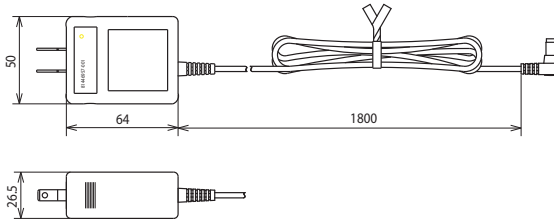

azbil

Azbil Corporation
Advanced Automation Company

1-12-2 Kawana, Fujisawa
Kanagawa 251-8522 Japan

URL: <http://www.azbil.com>

Specifications are subject to change without notice. (09)

1st edition: Dec. 2006 (U)
3rd edition: Sep. 2017 (V)