



## USER INSTRUCTIONS

### **Vertical Turbine Pumps Wet Pit (VTP) Double Casing (VPC)**

E, S and A series VTPs in wet pit and suction barrel designs ranging in sizes from 50 mm (6 in.) to 1300 mm (52 in.) with a single or multiple stages. (This manual does not cover VTPs fitted with thrust bearing assemblies and VTPs built for cryogenic service).

### **Installation Operation Maintenance**

PCN=71569224 10-13(E), Based on VTP-QS-0896 Original Instructions

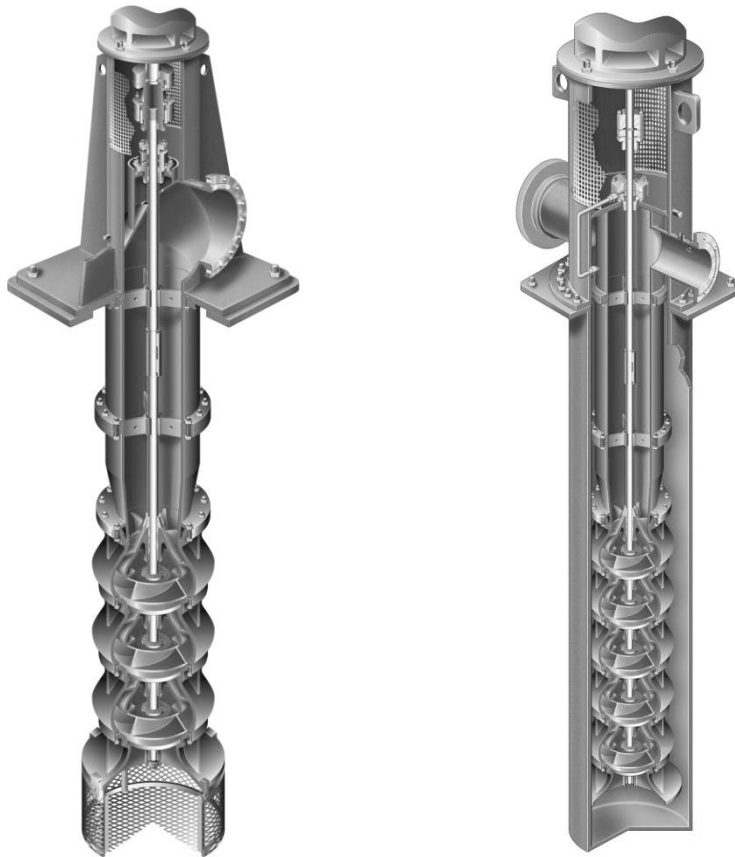

 **These instructions must be read prior to installing, operating, using and maintaining this equipment**

**CONTENTS**

|  | <b>PAGE</b> |   | <b>PAGE</b> |
|--|-------------|---|-------------|
| <b>1 INTRODUCTION AND SAFETY .....</b>         | <b>4</b>    | <b>6 MAINTENANCE .....</b>                      | <b>46</b>   |
| 1.1 General.....                               | 4           | 6.1 General .....                               | 47          |
| 1.2 CE Marking and Approvals.....              | 4           | 6.2 Maintenance Schedule .....                  | 47          |
| 1.3 Disclaimer.....                            | 4           | 6.3 Spare Parts .....                           | 49          |
| 1.4 Copyright.....                             | 4           | 6.4 Recommended Spares and Consumables ....     | 49          |
| 1.5 Duty Conditions .....                      | 4           | 6.5 Tools Required .....                        | 49          |
| 1.6 Safety .....                               | 5           | 6.6 Fastener Torques .....                      | 50          |
| 1.7 Safety Labels Summary .....                | 8           | 6.7 Setting Impeller Clearance.....             | 51          |
| 1.8 Specific Machine Performance.....          | 8           | 6.8 Disassembly.....                            | 51          |
| 1.9 Noise Level.....                           | 8           | 6.9 Examination of Parts.....                   | 51          |
| 1.10 Specific machine performance .....        | 9           | 6.10 Assembly.....                              | 55          |
| <b>2 TRANSPORT AND STORAGE.....</b>            | <b>10</b>   | <b>7 FAULTS; CAUSES AND REMEDIES .....</b>      | <b>56</b>   |
| 2.1 Consignment receipt and unpacking .....    | 10          | <b>8 DRAWINGS AND PARTS LISTS .....</b>         | <b>58</b>   |
| 2.2 Handling .....                             | 10          | 8.1 Cross Section: Product Lubricated VTP ..... | 58          |
| 2.3 Lifting .....                              | 10          | 8.2 Cross Section: Enclosed Tube VTP.....       | 61          |
| 2.4 Storage.....                               | 14          | 8.3 Cross Section: Suction Barrel VTP.....      | 64          |
| 2.5 Recycling and End of Product Life .....    | 14          | 8.4 General Arrangement Drawing .....           | 67          |
| <b>3 DESCRIPTION .....</b>                     | <b>14</b>   | <b>9 CERTIFICATION.....</b>                     | <b>67</b>   |
| 3.1 Configuration .....                        | 14          | <b>10 OTHER RELEVANT DOCUMENTATION AND</b>      |             |
| 3.2 Nomenclature .....                         | 16          | <b>MANUALS.....</b>                             | <b>67</b>   |
| 3.3 Design of Major Parts .....                | 17          | 10.1 Supplementary User Instructions.....       | 67          |
| 3.4 Performance and Operation Limits.....      | 21          | 10.2 Change Notes .....                         | 67          |
| <b>4 INSTALLATION.....</b>                     | <b>21</b>   | <b>11 APPENDIX .....</b>                        | <b>68</b>   |
| 4.1 Location .....                             | 21          | 11.1 Bill of Materials Reference Numbers .....  | 68          |
| 4.2 Preparation .....                          | 21          |   |             |
| 4.3 Foundation.....                            | 21          |   |             |
| 4.4 Grouting.....                              | 23          |   |             |
| 4.5 Lifting and Assembly .....                 | 24          |   |             |
| 4.6 Initial Alignment .....                    | 30          |   |             |
| 4.7 Piping.....                                | 31          |   |             |
| 4.8 Electrical Connections.....                | 34          |   |             |
| 4.9 Final Shaft Alignment Check .....          | 34          |   |             |
| 4.10 Protection Systems.....                   | 34          |   |             |
| <b>5 COMMISSIONING, STARTUP, OPERATION</b>     |             |   |             |
| <b>AND SHUTDOWN .....</b>                      | <b>35</b>   |   |             |
| 5.1 Pre-commissioning Procedure .....          | 35          |   |             |
| 5.2 Pump Lubricants .....                      | 35          |   |             |
| 5.3 Impeller Adjustment.....                   | 38          |   |             |
| 5.4 Direction of Rotation.....                 | 41          |   |             |
| 5.5 Guarding.....                              | 41          |   |             |
| 5.6 Priming and Auxiliary Supplies .....       | 41          |   |             |
| 5.7 Starting the Pump.....                     | 42          |   |             |
| 5.8 Operating the Pump .....                   | 45          |   |             |
| 5.9 Stopping and Shutdown .....                | 46          |   |             |
| 5.10 Hydraulic, mechanical and electrical duty | 46          |   |             |

**INDEX**

|  | <b>PAGE</b> |   | <b>PAGE</b> |
|--|-------------|---|-------------|
| Alignment of shafting (see 4.3, 4.6 and 4.9)     |             | Recycling (2.5)                               | 14          |
| Assembly (6.10)                                  | 55          | Replacement parts (6.3 and 6.4)               | 49          |
| ATEX marking (1.6.4.2)                           | 7           | Running the pump (5.8)                        | 45          |
| Bill of materials reference numbers (11.1)       | 68          | Safety action (1.6.3)                         | 5           |
| CE marking and approvals (1.2)                   | 4           | Safety labels (1.7.2)                         | 8           |
| Certification (9)                                | 67          | Safety markings (1.6.1)                       | 5           |
| Change notes (10.2)                              | 67          | Safety, protection systems (see 1.6 and 4.10) |             |
| Clearances, impeller (6.7)                       | 51          | Sealing arrangements (3.3.7)                  | 19          |
| Commissioning and operation (5)                  | 35          | Sectional drawings (8)                        | 58          |
| Compliance, ATEX (1.6.4.1)                       | 6           | Setting impeller clearance (6.7)              | 51          |
| Configurations (3.1)                             | 14          | Sound pressure level (1.9, Noise level)       | 8           |
| Copyright (1.4)                                  | 4           | Spare parts (6.3)                             | 49          |
| Design of major parts (3.3)                      | 17          | Specific machine performance (1.8)            | 8           |
| Direction of rotation (5.4)                      | 41          | Starting the pump (5.7)                       | 42          |
| Disassembly (6.8)                                | 51          | Stop/start frequency (5.7.8)                  | 45          |
| Disclaimer (1.3)                                 | 4           | Stopping and shutdown (5.9)                   | 46          |
| Dismantling (6.8, Disassembly)                   | 51          | Storage, pump (2.4)                           | 14          |
| Drawings (8)                                     | 58          | Storage, spare parts (6.3.3)                  | 49          |
| Duty conditions (1.5)                            | 4           | Supplementary manuals or info. sources (10)   | 67          |
| Electrical connections (4.8)                     | 34          | Supplementary User Instructions (10.1)        | 67          |
| End of product life (2.5)                        | 14          | Thermal expansion (4.6.1)                     | 30          |
| Examination of parts (6.9)                       | 52          | Tools required (6.5)                          | 49          |
| Fastener torques (6.6)                           | 50          | Torques for fasteners (6.6)                   | 50          |
| Faults; causes and remedies (7)                  | 56          | Trouble-shooting (7)                          | 56          |
| Foundation (4.3)                                 | 21          | Vibration (5.7.7)                             | 44          |
| General arrangement drawing (8.4)                | 67          |   |             |
| General assembly drawings (8)                    | 58          |   |             |
| Grouting (4.4)                                   | 23          |   |             |
| Guarding (5.5)                                   | 41          |   |             |
| Handling (2.2)                                   | 10          |   |             |
| Hydraulic, mechanical and electrical duty (5.10) | 46          |   |             |
| Impeller clearance (6.7)                         | 51          |   |             |
| Inspection (6.2.1 and 6.2.2)                     | 48          |   |             |
| Installation (4)                                 | 21          |   |             |
| Lifting (2.3)                                    | 10          |   |             |
| Location (4.1)                                   | 21          |   |             |
| Lubrication (5.2)                                | 35          |   |             |
| Maintenance (6)                                  | 47          |   |             |
| Maintenance schedule (6.2)                       | 47          |   |             |
| Name nomenclature (3.2)                          | 16          |   |             |
| Nameplate (1.7.1)                                | 8           |   |             |
| Nozzle loads (4.7.2)                             | 31          |   |             |
| Operating limits (3.4.1)                         | 21          |   |             |
| Ordering spare parts (6.3.1)                     | 49          |   |             |
| Parts lists (8)                                  | 58          |   |             |
| Performance (3.4)                                | 21          |   |             |
| Piping (4.7)                                     | 31          |   |             |
| Pre-commissioning (5.1)                          | 35          |   |             |
| Priming and auxiliary supplies (5.6)             | 41          |   |             |
| Protection systems (4.10)                        | 34          |   |             |
| Reassembly (6.10, Assembly)                      | 55          |   |             |
| Receipt and unpacking (2.1)                      | 10          |   |             |
| Recommended spares (6.4)                         | 499         |   |             |

## 1 INTRODUCTION AND SAFETY

### 1.1 General



***These instructions must always be kept close to the product's operating location or directly with the product.***

Flowserve products are designed, developed and manufactured with state-of-the-art technologies in modern facilities. The unit is produced with great care and commitment to continuous quality control, utilizing sophisticated quality techniques, and safety requirements.

Flowserve is committed to continuous quality improvement and being at service for any further information about the product in its installation and operation or about its support products, repair and diagnostic services.

These instructions are intended to facilitate familiarization with the product and its permitted use. Operating the product in compliance with these instructions is important to help ensure reliability in service and avoid risks. The instructions may not take into account local regulations; ensure such regulations are observed by all, including those installing the product. Always coordinate repair activity with operations personnel, and follow all plant safety requirements and applicable safety and health laws and regulations.



***These instructions must be read prior to installing, operating, using and maintaining the equipment in any region worldwide. The equipment must not be put into service until all the conditions relating to safety noted in the instructions, have been met. Failure to follow and apply the present user instructions is considered to be misuse. Personal injury, product damage, delay or failure caused by misuse are not covered by the Flowserve warranty.***

### 1.2 CE Marking and Approvals

It is a legal requirement that machinery and equipment put into service within certain regions of the world shall conform with the applicable CE Marking Directives covering Machinery and, where applicable, Low Voltage Equipment, Electromagnetic Compatibility (EMC), Pressure Equipment Directive (PED) and Equipment for Potentially Explosive Atmospheres (ATEX).

Where applicable the Directives and any additional Approvals cover important safety aspects relating to machinery and equipment and the satisfactory provision

of technical documents and safety instructions. Where applicable this document incorporates information relevant to these Directives and Approvals.

To confirm the Approvals applying and if the product is CE marked, check the serial number plate markings and the Certification. (See section 9, *Certification*.)

### 1.3 Disclaimer

***Information in these User Instructions is believed to be complete and reliable. However, in spite of all of the efforts of Flowserve Corporation to provide comprehensive instructions, good engineering and safety practice should always be used.***

Flowserve manufactures products to exacting International Quality Management System Standards as certified and audited by external Quality Assurance organizations. Genuine parts and accessories have been designed, tested and incorporated into the products to help ensure their continued product quality and performance in use. As Flowserve cannot test parts and accessories sourced from other vendors the incorrect incorporation of such parts and accessories may adversely affect the performance and safety features of the products. The failure to properly select, install or use authorized Flowserve parts and accessories is considered to be misuse. Damage or failure caused by misuse is not covered by the Flowserve warranty. In addition, any modification of Flowserve products or removal of original components may impair the safety of these products in their use.

### 1.4 Copyright

All rights reserved. No part of these instructions may be reproduced, stored in a retrieval system or transmitted in any form or by any means without prior permission of Flowserve.

### 1.5 Duty Conditions

This product has been selected to meet the specifications of your purchase order. The acknowledgement of these conditions has been sent separately to the Purchaser. A copy should be kept with these instructions.



***The product must not be operated beyond the parameters specified for the application. If there is any doubt as to the suitability of the product for the application intended, contact Flowserve for advice, quoting the serial number.***

If the conditions of service on your purchase order are going to be changed (for example liquid pumped, temperature or duty) it is requested that the user seeks the written agreement of Flowserve before start up.

## 1.6 Safety

### 1.6.1 Summary of safety markings

These User Instructions contain specific safety markings where non-observance of an instruction would cause hazards. The specific safety markings are:

 **DANGER** This symbol indicates electrical safety instructions where non-compliance will involve a high risk to personal safety or the loss of life.

 This symbol indicates safety instructions where non-compliance would affect personal safety and could result in loss of life.

 This symbol indicates “hazardous and toxic fluid” safety instructions where non-compliance would affect personal safety and could result in loss of life.

 **CAUTION** This symbol indicates safety instructions where non-compliance will involve some risk to safe operation and personal safety and would damage the equipment or property.

 This symbol indicates explosive atmosphere zone marking according to ATEX. It is used in safety instructions where non-compliance in the hazardous area would cause the risk of an explosion.

 This symbol is used in safety instructions to remind not to rub non-metallic surfaces with a dry cloth; ensure the cloth is damp. It is used in safety instructions where non-compliance in the hazardous area would cause the risk of an explosion.

**Note:** This sign is not a safety symbol but indicates an important instruction in the assembly process.

### 1.6.2 Personnel qualification and training

All personnel involved in the operation, installation, inspection and maintenance of the unit must be qualified to carry out the work involved. If the personnel in question do not already possess the necessary knowledge and skill, appropriate training and instruction must be provided. If required the operator may commission the manufacturer/supplier to provide applicable training.

Always coordinate repair activity with operations and health and safety personnel, and follow all plant safety requirements and applicable safety and health laws and regulations.

### 1.6.3 Safety action

***This is a summary of conditions and actions to prevent injury to personnel and damage to the environment and to equipment. For products***

***used in potentially explosive atmospheres section 1.6.4 also applies.***

 **DANGER** NEVER DO MAINTENANCE WORK WHEN THE UNIT IS CONNECTED TO POWER

 GUARDS MUST NOT BE REMOVED WHILE THE PUMP IS OPERATIONAL

 DRAIN THE PUMP AND ISOLATE PIPEWORK BEFORE DISMANTLING THE PUMP

The appropriate safety precautions should be taken where the pumped liquids are hazardous.

 **FLUORO-ELASTOMERS** (When fitted.) When a pump has experienced temperatures over 250 °C (482 °F), partial decomposition of fluoro-elastomers (example: Viton) will occur. In this condition these are extremely dangerous and skin contact must be avoided.

 **HANDLING COMPONENTS** Many precision parts have sharp corners and the wearing of appropriate safety gloves and equipment is required when handling these components. To lift heavy pieces above 25 kg (55 lb) use a crane appropriate for the mass and in accordance with current local regulations.

 **APPLYING HEAT TO REMOVE IMPELLER** There may be occasions when the impeller has either been shrunk fit on to the pump shaft or has become difficult to remove due to products of corrosion.

If you elect to use heat to remove the impeller, it must be applied quickly to the impeller boss. **TAKE GREAT CARE!**

Before applying heat ensure any residual hazardous liquid trapped between the impeller and pump shaft is thoroughly drained out through the impeller keyway to prevent an explosion or emission of toxic vapour. This must be carried out with the shaft in the vertical position. On some pump sizes a cavity exists in the impeller bore so on occasions a significant volume of liquid may drain out.

 **THERMAL SHOCK**

Rapid changes in the temperature of the liquid within the pump can cause thermal shock, which can result in damage or breakage of components and should be avoided.

 **HOT (and cold) PARTS**

If hot or freezing components or auxiliary heating supplies can present a danger to operators and persons entering the immediate area action must be



taken to avoid accidental contact. If complete protection is not possible, the machine access must be limited to maintenance staff only, with clear visual warnings and indicators to those entering the immediate area. Note: bearing housings must not be insulated and drive motors and bearings may be hot.

**If the temperature is greater than 80 °C (175 °F) or below -5 °C (23 °F) in a restricted zone, or exceeds local regulations, action as above shall be taken.**



**HAZARDOUS LIQUIDS**

When the pump is handling hazardous liquids care must be taken to avoid exposure to the liquid by appropriate siting of the pump, limiting personnel access and by operator training. If the liquid is flammable and/or explosive, strict safety procedures must be applied.

**Gland packing must not be used when pumping hazardous liquids.**



**CAUTION**

**PREVENT EXCESSIVE EXTERNAL PIPE LOAD**

Do not use pump as a support for piping. Do not mount expansion joints, unless allowed by Flowserve in writing, so that their force, due to internal pressure, acts on the pump flange.



**CAUTION**

**ENSURE CORRECT LUBRICATION**

(See section 5, *Commissioning, startup, operation and shutdown.*)



**CAUTION**

**START THE PUMP WITH OUTLET VALVE PARTLY OPENED**

(Unless otherwise instructed at a specific point in the User Instructions.)

This is recommended to minimize the risk of overloading and damaging the pump motor at full or zero flow. Pumps may be started with the valve further open only on installations where this situation cannot occur. The pump outlet control valve may need to be adjusted to comply with the duty following the run-up process. (See section 5, *Commissioning start-up, operation and shutdown.*)

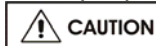

**CAUTION**

**NEVER RUN THE PUMP DRY**



**CAUTION**

**INLET VALVES TO BE FULLY OPEN WHEN PUMP IS RUNNING**

Running the pump at zero flow or below the recommended minimum flow continuously will cause damage to the pump and mechanical seal.

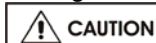

**CAUTION**

**DO NOT RUN THE PUMP AT ABNORMALLY HIGH OR LOW FLOW RATES**

Operating at a flow rate higher than normal or at a flow rate with no back pressure on the pump may overload

the motor and cause cavitations. Low flow rates may cause a reduction in pump/bearing life, overheating of the pump, instability and cavitation/vibration.

**1.6.4 Products used in potentially explosive atmospheres**



Measures are required to:

- Avoid excess temperature
- Prevent build up of explosive mixtures
- Prevent the generation of sparks
- Prevent leakages
- Maintain the pump to avoid hazard

The following instructions for pumps and pump units when installed in potentially explosive atmospheres must be followed to help ensure explosion protection. For ATEX, both electrical and non-electrical equipment must meet the requirements of European Directive 94/9/EC. Always observe the regional legal Ex requirements eg Ex electrical items outside the EU may be required certified to other than ATEX eg IECEx, UL.

**1.6.4.1 Scope of compliance**



Use equipment only in the zone for which it is appropriate. Always check that the driver, drive coupling assembly, seal and pump equipment are suitably rated and/or certified for the classification of the specific atmosphere in which they are to be installed.

Where Flowserve has supplied only the bare shaft pump, the Ex rating applies only to the pump. The party responsible for assembling the ATEX pump set shall select the coupling, driver and any additional equipment, with the necessary CE Certificate/ Declaration of Conformity establishing it is suitable for the area in which it is to be installed.

The output from a variable frequency drive (VFD) can cause additional heating affects in the motor and so, for pumps sets with a VFD, the ATEX Certification for the motor must state that it covers the situation where electrical supply is from the VFD. This particular requirement still applies even if the VFD is in a safe area.

**1.6.4.2 Marking**

An example of ATEX equipment marking is shown below. The actual classification of the pump will be engraved on the nameplate.

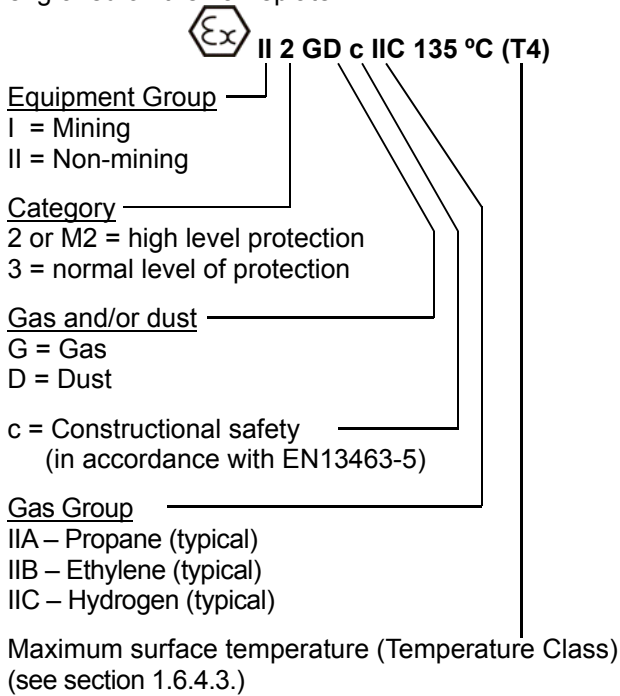

**1.6.4.3 Avoiding excessive surface temperatures**



ENSURE THE EQUIPMENT TEMPERATURE CLASS IS SUITABLE FOR THE HAZARD ZONE

Pumps have a temperature class as stated in the ATEX Ex rating on the nameplate. These are based on a maximum ambient of 40 °C (104 °F); refer to Flowserve for higher ambient temperatures.

The surface temperature on the pump is influenced by the temperature of the liquid handled. The maximum permissible liquid temperature depends on the temperature class and must not exceed the values in the table that follows.

| Temperature class to EN13463-1 | Maximum surface temperature permitted | Temperature limit of liquid handled * |
|--------------------------------|---------------------------------------|---------------------------------------|
| T6                             | 85 °C (185 °F)                        | Consult Flowserve                     |
| T5                             | 100 °C (212 °F)                       | Consult Flowserve                     |
| T4                             | 135 °C (275 °F)                       | 115 °C (239 °F)                       |
| T3                             | 200 °C (392 °F)                       | 180 °C (356 °F)                       |
| T2                             | 300 °C (572 °F)                       | 275 °C (527 °F)                       |
| T1                             | 450 °C (842 °F)                       | 400 °C (752 °F)                       |

\* The table only takes the ATEX temperature class into consideration. Pump design or material, as well as component design or material, may further limit the maximum working temperature of the liquid.

The temperature rise at the seals and bearings and due to the minimum permitted flow rate is taken into account in the temperatures stated.

**The operator is responsible to ensure that the specified maximum liquid temperature is not exceeded**

Temperature classification “Tx” is used when the liquid temperature varies and the pump could be installed in different hazardous atmospheres. In this case the user is responsible for ensuring that the pump surface temperature does not exceed that permitted in the particular hazardous atmosphere.

If an explosive atmosphere exists during the installation, do not attempt to check the direction of rotation by starting the pump unfilled. Even a short run time may give a high temperature resulting from contact between rotating and stationary components.

Where there is any risk of the pump being run against a closed valve generating high liquid and casing external surface temperatures, fit an external surface temperature protection device.

Avoid mechanical, hydraulic or electrical overload by using motor overload trips, temperature monitor or a power monitor and make routine vibration monitoring checks.

In dirty or dusty environments, make regular checks and remove dirt from areas around close clearances, bearing housings and motors.

**1.6.4.4 Preventing the buildup of explosive mixture**



ENSURE THE PUMP IS PROPERLY FILLED AND VENTED AND DOES NOT RUN DRY

Ensure the pump and relevant suction and discharge pipeline system is totally filled with liquid at all times during the pump operation, so that an explosive atmosphere is prevented. In addition it is essential to make sure that seal chambers, auxiliary shaft seal systems and any heating and cooling systems are properly filled.

If the operation of the system cannot avoid this condition, fit an appropriate dry run protection device (for example liquid detection or a power monitor).

To avoid potential hazards from fugitive emissions of vapor or gas to atmosphere the surrounding area must be well ventilated.

1.6.4.5 **Preventing sparks**



To prevent a potential hazard from mechanical contact, the coupling guard must be non-sparking.

To avoid the potential hazard from random induced current generating a spark, the base plate must be properly grounded.



Avoid electrostatic charge: do not rub non-metallic surfaces with a dry cloth; ensure cloth is damp.

For ATEX applications the coupling must be selected to comply with 94/9/EC. Correct coupling alignment must be maintained.

**Additional requirement for metallic pumps on non-metallic base plates**

When metallic components are fitted on a non-metallic base plate they must be individually earthed.

1.6.4.6 **Preventing leakage**



The pump must only be used to handle liquids for which it has been approved to have the correct corrosion resistance.

Avoid entrapment of liquid in the pump and associated piping due to closing of suction and discharge valves, which could cause dangerous excessive pressures to occur if there is heat input to the liquid. This can occur if the pump is stationary or running.

Bursting of liquid containing parts due to freezing must be avoided by draining or protecting the pump and ancillary systems.

Where there is the potential hazard of a loss of a seal barrier fluid or external flush, the fluid must be monitored.

If leakage of liquid to atmosphere can result in a hazard, install a liquid detection device.

1.6.4.7 **Maintenance to avoid the hazard**



CORRECT MAINTENANCE IS REQUIRED TO AVOID POTENTIAL HAZARDS WHICH GIVE A RISK OF EXPLOSION

**The responsibility for compliance with maintenance instructions is with the plant operator.**

To avoid potential explosion hazards during maintenance, the tools, cleaning and painting materials used must not give rise to sparking or

adversely affect the ambient conditions. Where there is a risk from such tools or materials, maintenance must be conducted in a safe area.

It is recommended that a maintenance plan and schedule is adopted. (See section 6, *Maintenance*.)

1.7 **Safety Labels Summary**

1.7.1 **Nameplate**

For details of nameplate, see the *Declaration of Conformity*, or separate documentation included with these User Instructions.

1.7.2 **Safety labels**

|  |  |   |           |
|--|--|---|-----------|
| <b>FLOWSERVE</b>   |  | <b>WARNING</b>  | J218JZ250 |
| <b>ESSENTIAL PROCEDURES BEFORE STARTING:</b>   |  |   |           |
| <b>INSTALL AND OPERATE EQUIPMENT IN ACCORDANCE WITH THE INSTRUCTION MANUAL SUPPLIED SEPARATELY.</b><br><b>ENSURE GUARDS ARE SECURELY IN PLACE.</b><br><b>ENSURE CORRECT DIRECTION OF ROTATION.</b> | <b>ENSURE ALL EXTERNAL CONNECTIONS TO THE PUMP / SHAFT SEALING AND DRIVER ARE CONNECTED AND OPERATIONAL.</b><br><b>FULLY PRIME UNIT AND SYSTEM. DO NOT RUN UNIT DRY.</b> | <b>FAILURE TO FOLLOW THESE PROCEDURES MAY RESULT IN PERSONAL INJURY AND / OR EQUIPMENT DAMAGE</b> |           |
| <p style="text-align: center;">CDC: 603 604 610 612 621 623 624</p>  |  |   |           |

|   |  |
|---|--|
| J218/268  |  |
| <b>ENSURE UNIT ON A FIRM FOUNDATION AND THAT COUPLING FACES ARE IN CORRECT ALIGNMENT PRIOR TO AND AFTER BOLTING BASEPLATE DOWN AND FIXING PIPEWORK. SEE MANUAL FOR TOLERANCES.</b>  | <b>PUMP MUSS AUF FESTEM FUNDAMENT STEHEN. KÜPPLUNGSHÄLFTEN KORREKT AXIAL AUSRICHTEN, DANN PUMPE AUF GRUNDPLATTE FESTSPANNEN UND ANSCHLUSSLEITUNGEN BEFESTIGEN. TOLERANZEN S. BEDIENUNGSANLEITUNG.</b>  |
| <b>S'ASSURER QUE LE GROUPE ELECTROPOMPE EST FERMEMENT INSTALLE SUR SON MASSIF. VERIFIER LE LIGNAGE DE L'ACCOUPLLEMENT AVANT ET APRES FIXATION DU SOCLE ET DE LA TUYAUTERIE. VOIR LES TOLERANCES D'ALIGNMENT SUR LA NOTICE</b> | <b>ZORG DAT POMPEENHEID OP EEN STEVIGE ONDERGROND OPGESTELD STAAT EN DAT KOPPELING CORRECT UITGELIJNT IS ZOWEL VOOR ALS NADAT DE GRONDPLAAT MET BOUTEN IS VASTGEZET EN DE LEIDINGEN GEINSTALLEERD ZIJN. ZIE HANDLEIDING VOOR TOELAABARE SPELINGEN.</b> |
| <p style="text-align: center;">CDC: 603 604 610 612 621 623 624</p>   |  |

Oil lubricated units only:

|   |   |
|---|---|
| J218JZ262   |   |
| <b>WARNING</b><br><b>ATTENTION</b><br><b>ACHTUNG</b><br><b>WAARSCHUWING</b> | <b>THIS MACHINE MUST BE FILLED WITH OIL BEFORE STARTING</b><br><b>CETTE MACHINE DOIT ÊTRE REMPLIE D'HUILE AVANT LA MISE EN MARCHÉ</b><br><b>DIESE MASCHINE IST VOR DEM STARTEN MIT ÖL ZÜ FULLEN</b><br><b>DEZE MACHINE MOET VOOR HET STARTEN MET OLIE GEVULD WORDEN</b> |
| <p style="text-align: center;">CDC: 603 604 610 612 621 623 624</p>         |   |

1.8 **Specific Machine Performance**

For performance parameters see section 1.5, *Duty conditions*. When the contract requirement specifies these to be incorporated into User Instructions these are included here. Where performance data has been supplied separately to the purchaser these should be obtained and retained with these User Instructions if required.

1.9 **Noise Level**

Attention must be given to the exposure of personnel to the noise, and local legislation will define when guidance to personnel on noise limitation is required, and when noise exposure reduction is mandatory. This is typically 80 to 85 dBA.



The usual approach is to control the exposure time to the noise or to enclose the machine to reduce emitted sound. You may have already specified a limiting noise level when the equipment was ordered, however if no noise requirements were defined, then attention is drawn to the following table to give an indication of equipment noise level so that you can take the appropriate action in your plant.

Pump noise level is dependent on a number of operational factors, flow rate, pipework design and acoustic characteristics of the building, and so the values given are subject to a 3 dBA tolerance and cannot be guaranteed.

Similarly the motor noise assumed in the “pump and motor” noise is that typically expected from standard and high efficiency motors when on load directly driving the pump. Note that a motor driven by an inverter may show an increased noise at some speeds.

If a pump unit only has been purchased for fitting with your own driver then the “pump only” noise levels in the table should be combined with the level for the driver obtained from the supplier. Consult Flowserve or a noise specialist if assistance is required in combining the values.

It is recommended that where exposure approaches the prescribed limit, then site noise measurements should be made.

The values are in sound pressure level  $L_{pA}$  at 1 m (3.3 ft) from the machine, for “free field conditions over a reflecting plane”.

For estimating sound power level  $L_{WA}$  (re 1pW) then add 17 dBA to the sound pressure value.

**Note:** The noise levels shown in table 1.9.1 are extracted from typical motor manufacturer’s data/catalogue to provide the average expected motor noise values at no load for reference only and are not guaranteed. The values could vary depending upon the test and surrounding conditions. The combined noise level of the pump and the motor could exceed the values shown. It is to be noted that adding motors with similar noise levels increases the total noise level. Therefore, the dB correction to the values listed above is required to obtain the combined noise levels of motor and the pump. Actual on-site noise measurement by experts is recommended and safety measures are to be taken accordingly.

1.9.1 Typical vertical motor noise data (Hollow and Solid shafts)

| Motor Frame Size. NEMA | RPM           | Sound Pressure (dBA ) (WP- I enclosure) | Sound Power (dBA ) (WP- I enclosure) |
|------------------------|---------------|---|--------------------------------------|
| 180                    | 3600          | 70.0                                    | 78.0                                 |
|                        | 1800          | 60.0                                    | 68.0                                 |
|                        | 1200 & slower | 55.0                                    | 63.0                                 |
| 210                    | 3600          | 70.0                                    | 78.2                                 |
|                        | 1800          | 60.0                                    | 68.2                                 |
|                        | 1200 & slower | 55.0                                    | 63.2                                 |
| 250                    | 3600          | 75.0                                    | 83.4                                 |
|                        | 1800          | 70.0                                    | 78.4                                 |
|                        | 1200 & slower | 60.0                                    | 68.4                                 |
| 280                    | 3600          | 75.0                                    | 83.8                                 |
|                        | 1800          | 70.0                                    | 78.8                                 |
|                        | 1200 & slower | 60.0                                    | 68.8                                 |
| 320                    | 3600          | 75.0                                    | 84.0                                 |
|                        | 1800          | 65.0                                    | 74.0                                 |
|                        | 1200 & slower | 65.0                                    | 74.0                                 |
| 360                    | 3600          | 75.0                                    | 84.2                                 |
|                        | 1800          | 65.0                                    | 74.2                                 |
|                        | 1200 & slower | 65.0                                    | 74.2                                 |
| 400                    | 3600          | 80.0                                    | 89.5                                 |
|                        | 1800          | 70.0                                    | 79.5                                 |
|                        | 1200 & slower | 65.0                                    | 74.5                                 |
| 440                    | 3600          | 80.0                                    | 90.0                                 |
|                        | 1800          | 70.0                                    | 80.0                                 |
|                        | 1200 & slower | 70.0                                    | 80.0                                 |
| 449                    | 1800          | 85.0                                    | 97.8                                 |
|                        | 1200 & slower | 80.0                                    | 92.8                                 |
| 5000                   | 3600          | 90.0                                    | 102.8                                |
|                        | 1800          | 85.0                                    | 97.8                                 |
|                        | 1200 & slower | 80.0                                    | 92.8                                 |
| 5800                   | 3600          | 90.0                                    | 103.7                                |
|                        | 1800          | 90.0                                    | 103.7                                |
|                        | 1200 & slower | 80.0                                    | 93.7                                 |
| 6800                   | 1800          | 90.0                                    | 103.9                                |
|                        | 1200 & slower | 85.0                                    | 98.8                                 |
| 8000                   | 1800          | 90.0                                    | 104.7                                |
|                        | 1200 & slower | 85.0                                    | 99.7                                 |

1.10 Specific machine performance

For performance, parameters see section 1.5, *Duty conditions*. Whenever there is a contract requirement to incorporate specific machine performance into User Instructions, those are included here. In cases where performance data has been supplied separately to the purchaser, the same should be retained with these User Instructions, if required.

## 2 TRANSPORT AND STORAGE

### 2.1 Consignment receipt and unpacking

Immediately after receipt of the equipment it must be checked against the delivery and shipping documents for its completeness and that there has been no damage in transportation. Any shortage and or damage must be reported immediately to Flowserve and received in writing within one month of receipt of the equipment. Later claims cannot be accepted.

Check any crates, boxes and wrappings for any accessories or spare parts which may be packed separately with the equipment or attached to side walls of the box or equipment.

Each product has a unique serial number. Check that this number corresponds with that advised and always quote this number in correspondence as well as when ordering spare parts or further accessories.

### 2.2 Handling

Boxes, crates, pallets or cartons may be unloaded using fork lift vehicles or slings dependent on their size and construction.

### 2.3 Lifting



Equipment in excess of 25Kg (55lbs) should be lifted by mechanical means. Fully trained personnel must carry out lifting, in accordance with local regulations.

Before lifting the driver alone, refer to the manufacturer's instructions.

#### 2.3.1 Lifting of W-type cast discharge head (head only-pump not attached)

Lift the unassembled cast discharge heads (pump not attached) by installing eyebolts as shown using the flange mounting holes. Lower the head over shaft into place.

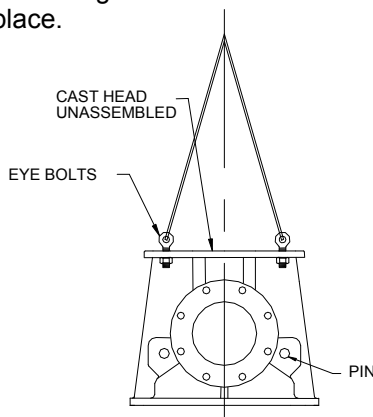

Do not use the lifting pins at the base of the discharge head while lifting unassembled cast discharge heads unless the discharge head is secured by slings to prevent overturning. **Never lift the completely assembled pump with eyebolts through this flange.**

#### 2.3.2 Lifting of type-W cast discharge head with pump attached

Cast discharge heads with pump attached are recommended to be lifted by using pins suitable with that head size (refer to the table shown). The slings are attached as shown maintaining minimum length of the sling from the shaft end as shown in the detail.

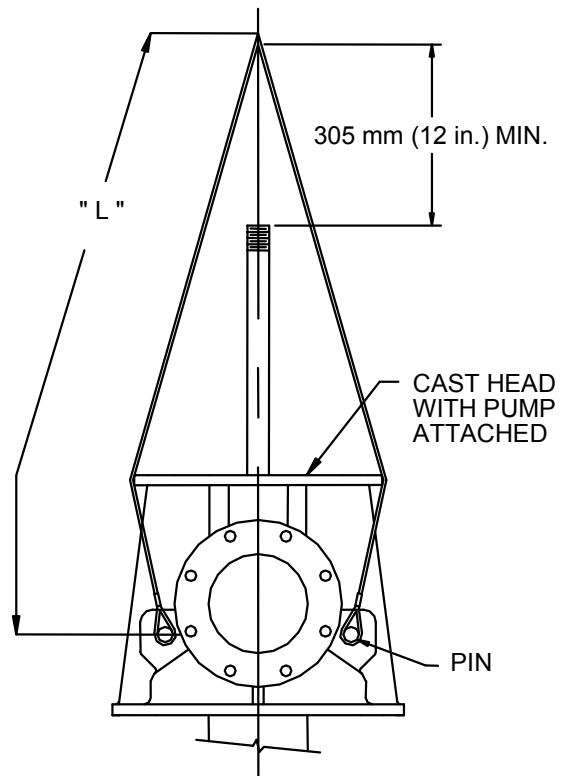

|                 | Cast heads with discharge size mm (in.) |              |              |              |              |
|-----------------|---|--------------|--------------|--------------|--------------|
|                 | 100<br>(4)                              | 150<br>(6)   | 200<br>(8)   | 250<br>(10)  | 300<br>(12)  |
| <b>Pin Dia.</b> | 25<br>(1)                               | 32<br>(1.25) | 32<br>(1.25) | 32<br>(1.25) | 38<br>(1.5)  |
| <b>L</b>        | 1220<br>(48)                            | 1370<br>(54) | 1370<br>(54) | 1520<br>(60) | 1520<br>(60) |

"L" is approximate length

#### 2.3.3 Lifting of fabricated discharge heads with or without the pump

If the pump is supplied with a fabricated discharge head use 2 point or 3 point method of lifting as shown in the details provided in 2.3.3.1 & 2.3.3.2. This method is applicable to the lifting of discharge heads with or without the pump.

**2.3.3.1 Two point lifting of fabricated discharge head types TF, UF & HFH (with or without pump attached)**

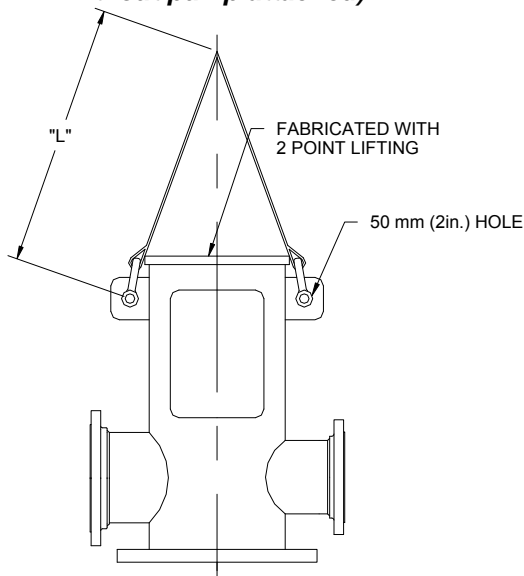

|                 | Fabricated heads with discharge size mm (in.) |                    |                    |
|-----------------|---|--------------------|--------------------|
|                 | 100-200<br>(4-8)                              | 250-600<br>(10-24) | 700-900<br>(28-36) |
| <b>Pin Dia.</b> | 32 (1.25)                                     | 38 (1.50)          | 44 (1.75)          |
| <b>Weight</b>   | <2300 (5000)                                  | <4500 (10000)      | <6800 (15000)      |

**2.3.3.2 Three point lifting of fabricated discharge head of type HFL (with or without pump attached)**

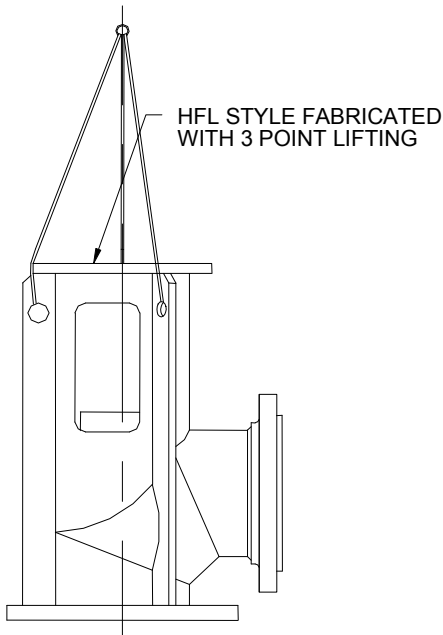

**2.3.4 Lifting of bowl assembly only**

Clamp the bowl assembly and center the lifting hook for lifting and lowering the assembly into the sump/suction barrel.

- Lower the bowl assembly until the clamp extensions rest on the foundation (use appropriate supports).
- Build the very first section of the column piping, and lower the entire assembly to assemble the next column section.
- Continue to build until it is ready for discharge head assembly.
- Install the discharge head.
- Assemble the motor.

Example: Lifting of bowl assembly

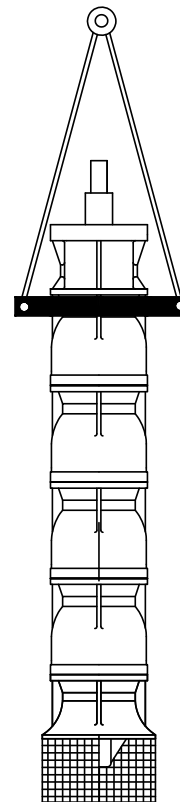

**2.3.5 Lifting of suction barrel**

Suction barrel (also referred as 'Can') is always supplied separately and has to be installed into the sump first. Install eyebolts on the flange of the suction barrel and attach slings and straps to bring the suction barrel to a vertical position. Move the barrel for installation. Provide hand support to prevent the suction barrel from swaying during movement.

Example: Lifting of suction barrel

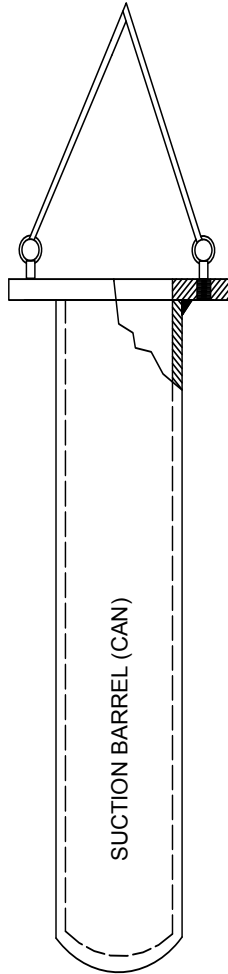

**2.3.6 Lifting of fully assembled pumps**

If the pump is fully assembled, it has to be adequately strapped and supported at least two places before it can be lifted from the shipping crate and moved to the installation site. See details shown. Same rules are applicable when the pump is pulled out from the sump and moved to another location.

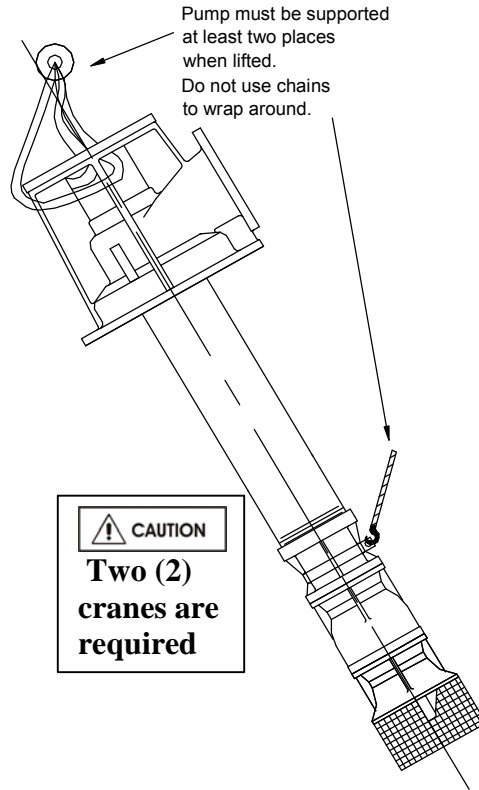

**CAUTION**  
**Two (2) cranes are required**

**CAUTION**

Examples shown here are for illustration only. See section 2.3 1~2.3.6 for specific lifting instructions based on design variations. The pumps vary in weight, length and physical appearances from the types shown here.



Therefore, before lifting is attempted, exercise caution to prevent any injuries or loss of life.

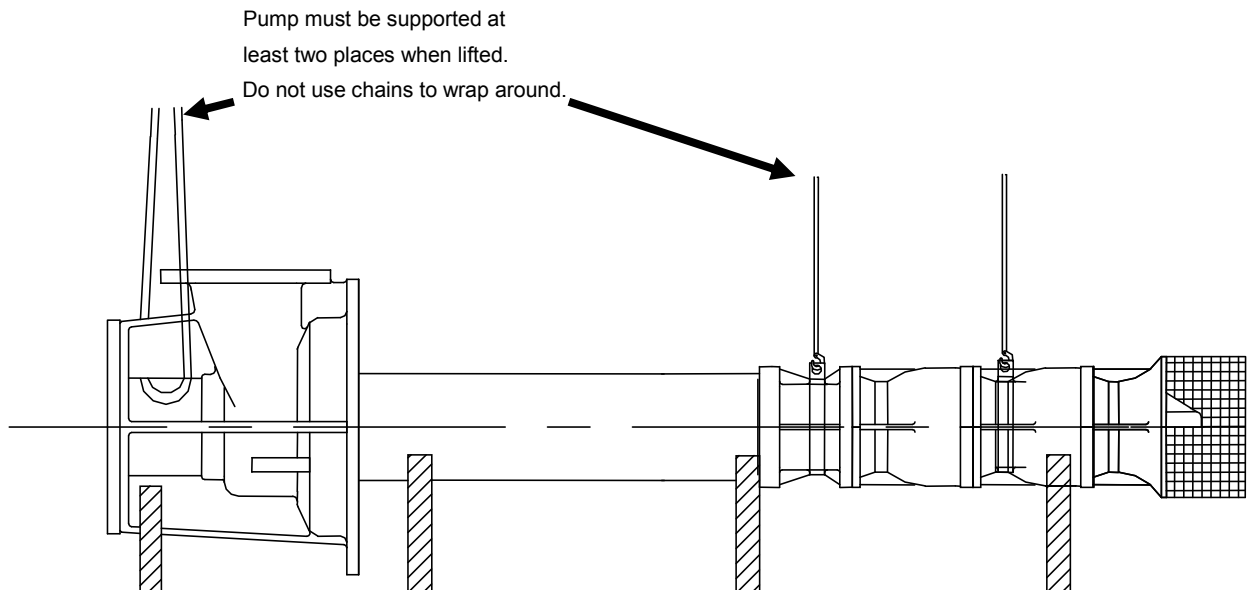



## 2.4 Storage



Store the pump in a clean, dry location away from vibration. Leave piping connection covers in place to keep dirt and other foreign material out of pump casing. Turn the pump at frequent intervals to prevent brinelling of the bearings and the seal faces, if fitted, from sticking.

### 2.4.1 Inspection before storage

- a) Inspect the preservative coating/painted surfaces on the various parts. Touch up the areas, if necessary.
- b) Inspect all covers over pump openings and piping connections. If found damaged, remove the covers and inspect interiors of the opening for any deposits of foreign materials or water.
- c) If necessary, clean and preserve the interior parts as noted above to restore the parts to the "as shipped" condition. Replace covers and fasten securely.
- d) Exercise caution with pumps exposed to weather. Containers are not leak proof. Parts may be coated with a residual amount of protective coating, which will wash away if exposed to elements.

### 2.4.2 Short term storage (up to 6 months)

Follow the steps given in section 2.4.1. Select a storage space so that the unit will not be subjected to excess moisture, extreme weather conditions, corrosive fumes, or other harmful conditions.

Driver storage instructions: Check driver manufacturer's User Instructions

### 2.4.3 Long term or extended storage

If a situation arises for a long-term storage, ( more than 6 months) please contact Flowserve for special storage instructions and warranty related information.

## 2.5 Recycling and End of Product Life

At the end of the service life of the product or its parts, the relevant materials and parts should be recycled or disposed of using an environmentally acceptable method and local regulations. If the product contains substances which are harmful to the environment, these should be removed and disposed of in accordance with current regulations. This also includes the liquids and or gases in the "seal system" or other utilities.



Make sure that hazardous substances or toxic fluids are disposed of safely and that the correct

personal protective equipment is used. The safety specifications must be in accordance with the current regulations at all times.

## 3 DESCRIPTION

Should questions arise concerning the pump, Flowserve pump division will require the complete serial number to be of assistance. The serial number is stamped on a metal nameplate affixed to the discharge head assembly. The driver will have a separate nameplate attached to it. If you are requesting information on the driver, please provide both the driver serial number and the pump serial number for Flowserve representative.

### 3.1 Configuration

VTPs, are engineered pumps as:(a) Wet pit type and (b) suction barrel (can) type pumps. Most pumps are built with customer specific features and for applications such as water pumping stations, deep wells, storm water service, industrial and cryogenic applications. The pumps vary in size, impeller types and length, whether it is an open shaft or enclosed shaft designs and type of discharge head used.

3.1.1 Sump and deep well VTP

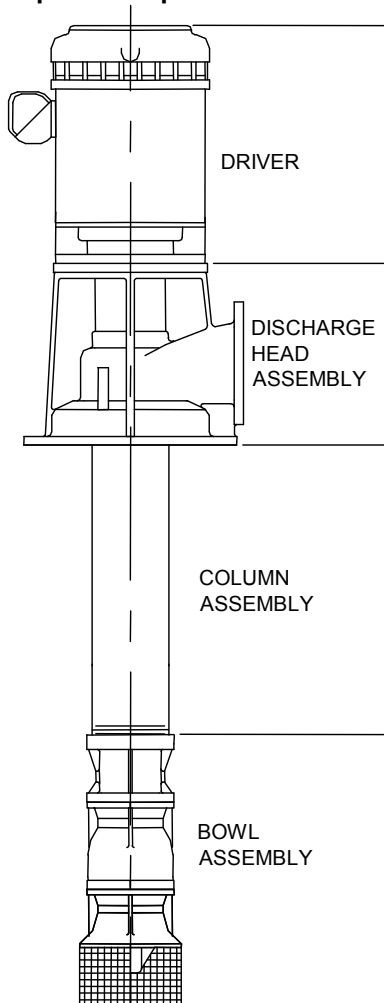

3.1.2 Suction barrel (Can) VTP

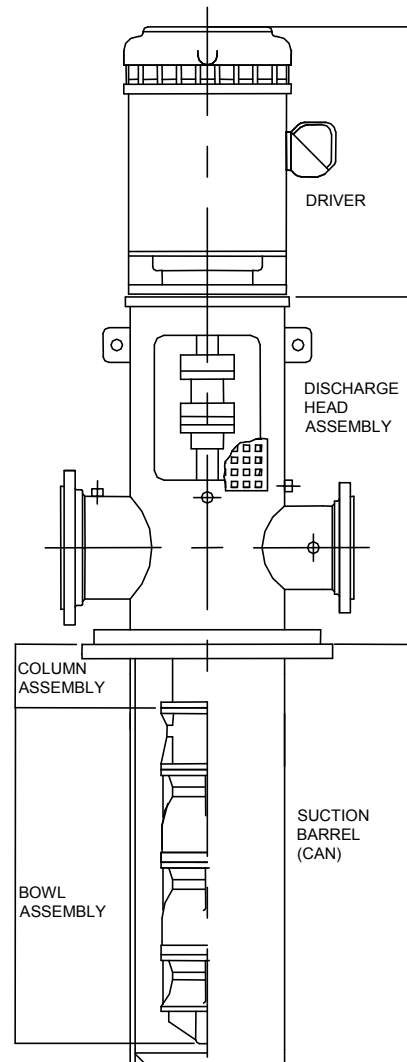

3.1.3 Most common VTP models

The VTP configurations shown in sec 3.1.1 and 3.1.2 are typical for variety of VTP models with the bowl assembly types such as **EB, EG, EH, EJ, EK, EL, EM, EN, EP, EQ, SK, SL, SN, SP, SR, ST, & AV**. The impeller models in each of these pumps are designated separately (see section 3.2 for more details) and the pump sizes could vary from 150mm (6 in) to 1300 mm (52 in.). The size expressed is in terms of nominal bowl diameter and is always in inches.

**Note:**

Some units will not require a column assembly. In such cases, the bowl assembly is connected directly to the discharge head. Vertical turbine pumps can have single or multiple stages.

### 3.2 Nomenclature

The pump size/ serial number will be engraved on the nameplate typically as below: The nameplate is attached to the discharge head assembly.

#### 3.2.1 Bowl assembly nomenclature

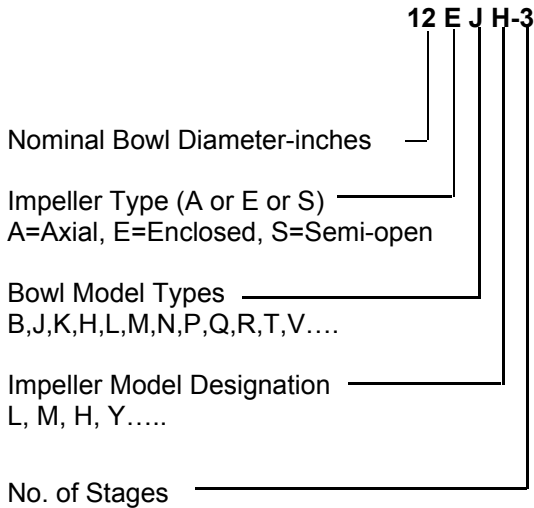

The typical nomenclature above is the general guide to the VTP configuration description. Identify the actual pump size and serial number from the pump nameplate. The driver will have a separate nameplate attached it.

#### 3.2.2 Discharge head nomenclature

Consists of alphanumeric code as follows. Examples: 8W16, 10HF20, 6TF16,.....

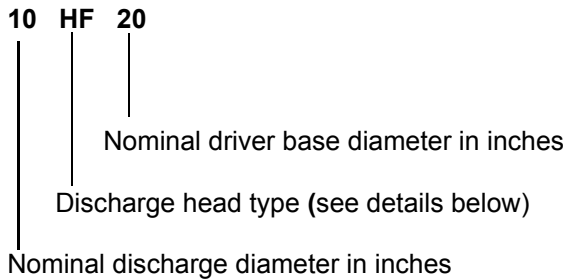

- W** = Cast head- for horizontal above the ground discharge
- HF** = Fabricated head for above the ground discharge
- TF & LF** = Fabricated heads with base flange
- UF** = Fabricated head for below ground discharge
- HFL** = Fabricated head for above ground discharge - Low H.P
- HFH** = Fabricated head for above the ground discharge -High H.P.

Please see section 3.2.2.1 for discharge head types and identification.

#### 3.2.2.1 Types of discharge heads

Typical discharge head types. Details (a) thru (g).

a) W type cast discharge head

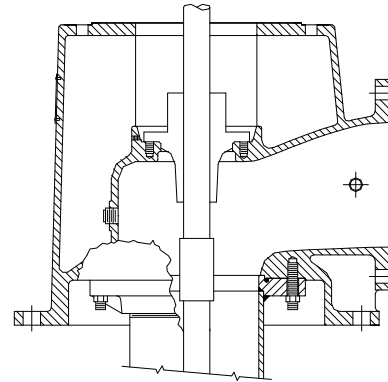

b) HF type fabricated discharge head (Typically with square base plate)

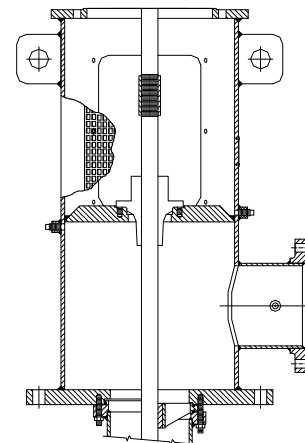

c) TF type fabricated discharge head

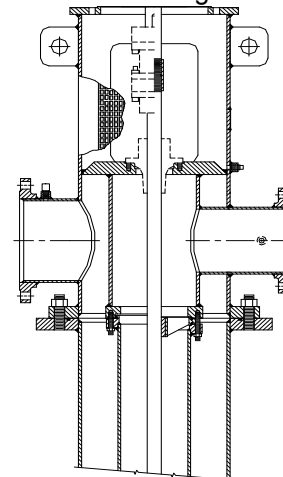

- d) LF type fabricated discharge head  
(Typically with a circular base plate- ANSI type.  
Also available with suction barrel mounting)

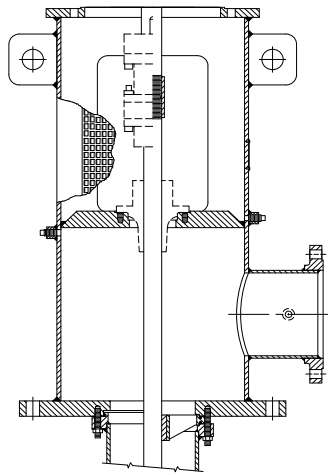

- g) HFH type fabricated discharge head

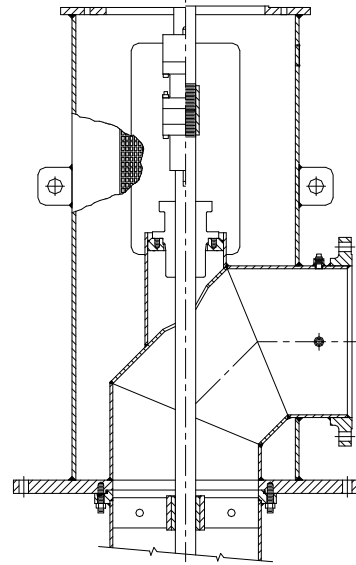

- e) UF type fabricated discharge head

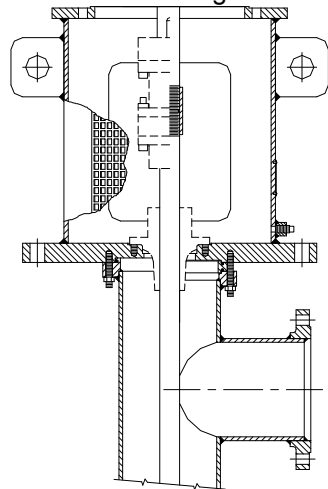

- f) HFL type fabricated discharge head

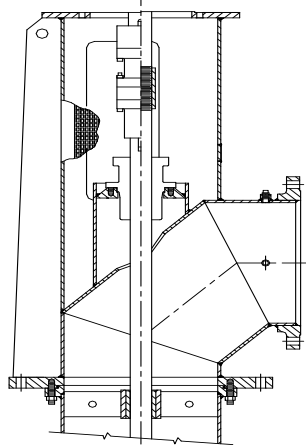

**Note:**

The discharge heads shown in section 3.2.2.1 (a) thru (g) are for illustration only. The shaft and coupling arrangements vary. For the actual configuration of the pump that has been purchased, please refer to the drawings supplied with the pump or order specific sectionals from Flowserve.

### 3.3 Design of Major Parts

**Note:**

Please refer to appendix for Europump part number equivalents

#### 3.3.1 Drivers

A variety of drivers may be used, however, electric motors are most common. For the purposes of this manual, all types of drivers can be grouped into two categories.

a) Hollow shaft drivers: where the head shaft extends through a tube in the center of the rotor and is connected to the driver by a clutch assembly at the top of the driver.

b) Solid shaft drivers: where the rotor shaft is solid and projects below the driver-mounting base. This type driver requires an adjustable coupling for connecting to the pump.

#### 3.3.2 Discharge Head Assembly

(See also section 3.2.2.1)

The discharge head supports the driver and bowl assembly as well as supplying a discharge connection in most cases.

A shaft sealing arrangement is located in the discharge head to seal the shaft at its exit from the liquid chamber.

The shaft seal will usually be either a mechanical seal assembly or stuffing box with an open lineshaft or a tube-packing box with an enclosed lineshaft.

**3.3.3 Column assembly**

The column assembly consists of column pipe, which connects the bowl assembly to the discharge head and carries the pumped fluid to the discharge head. Houses and supports the shaft and may contain bearings. Typical column assemblies are:

- a) flanged column assembly

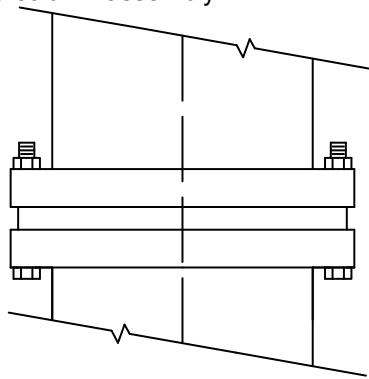

- b) threaded column assembly: from 100 mm~355 mm (4~14 in.) sizes only.

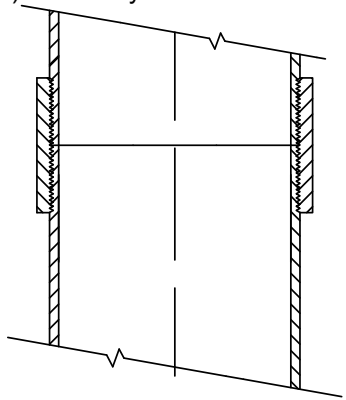

The column supports shaft assembly, that is either

- a) Open lineshaft construction utilizing the fluid being pumped to lubricate the lineshaft bearings.

**Or**

- b) Enclosed lineshaft construction has an enclosing tube around the lineshaft and utilizes oil or other fluid to lubricate the lineshaft bearings.

The shafts are threaded or key coupled with thrust stud design or clamp ring design.

See sectional drawings supplied with the pump for exact column assembly details as per the order. The size and configuration vary depending upon the specific order requirements and application criteria.

**3.3.4 Bowl assemblies**

The bowl assembly consists of impellers rigidly mounted on the pump shaft coupled to an electric motor. Impellers are cast wheels with multiple diffuser vanes and are generally coated to meet the hydraulic requirements. See section 8.0 for cross sectional and part details.

**3.3.5 Suction strainers**

VTPs can also be fitted with strainers [316] to prevent foreign particles from entering the pump. The type of strainers and the mesh size depends on the application. Examples are shown below. Strainers are fastened [422] directly to the suction bell [55] or attached using clips [421]. Cone shaped strainers are provided with internal or external threads to attach it to the main assembly.

- a) Slip-on strainer

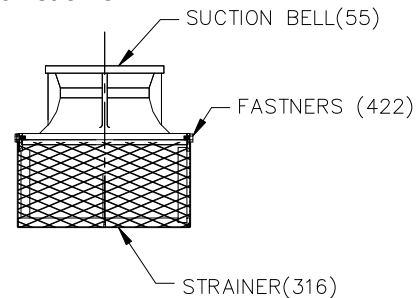

- b) Clip-on strainer

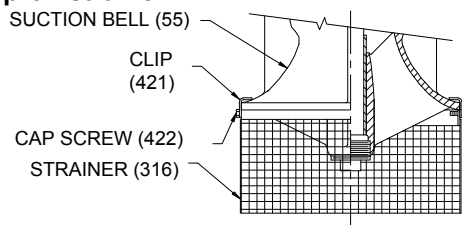

- c) Cone (threaded) strainer

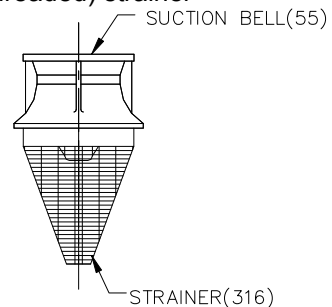



d) Bolt on strainer

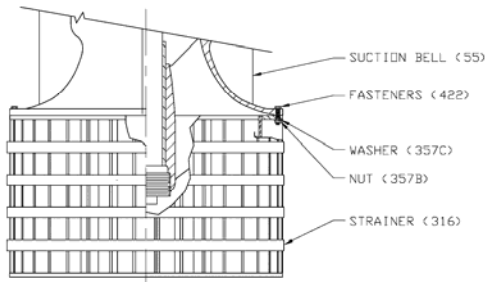

3.3.6 Impellers

VTP's are supplied with enclosed, or semi open impeller types. Impellers are low, medium and high capacity type designed for maximum coverage of all VTP applications. Impellers are cast and machined to match each order and to provide required surface finish to achieve hydraulic characteristics. Impellers are dynamically balanced and held in position on the shaft by a tapered lock collet or split ring and key.

3.3.7 Stuffing box

Some VTPs are fitted with stuffing boxes. In such cases, stuffing boxes are normally adequate for working pressures up to 20.7 bar (300 psi). Refer to stuffing box User Instructions for specifications.

3.3.7.1 Low pressure stuffing box

This type of packing box is fitted on to an open lineshaft for pressures less than 6.5 bar (100 psi) and used only on W-type discharge heads (see Section 3.2.2.1 to see for W type discharge head detail).

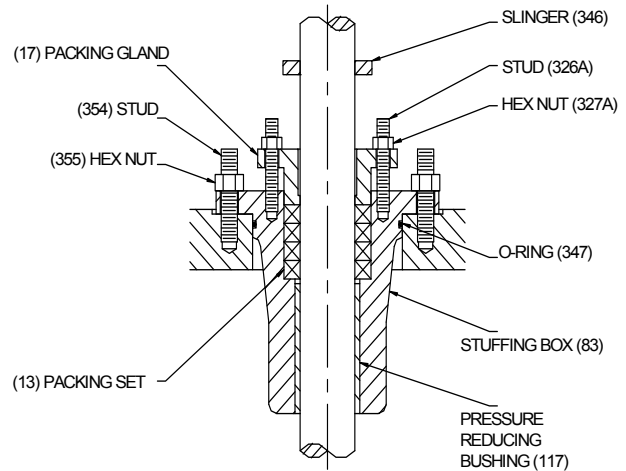

3.3.7.2 High pressure stuffing box

This type of packing box is fitted on to an open lineshaft for pressures up to 20 bar (300 psi) uses six rings of packing with two lantern rings and allows grease lubrication.

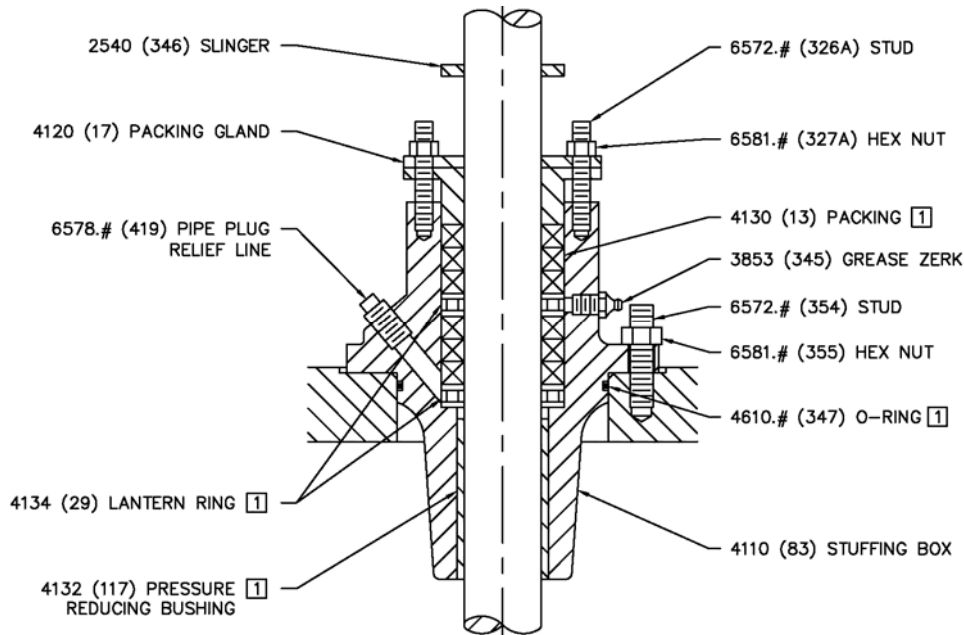

**3.3.7.4 Extra high pressure stuffing box**

In cases where the pressures are expected to cross 20 bar (300 psi) up to 65 bar (1000 psi), extra high-pressure stuffing box is used.

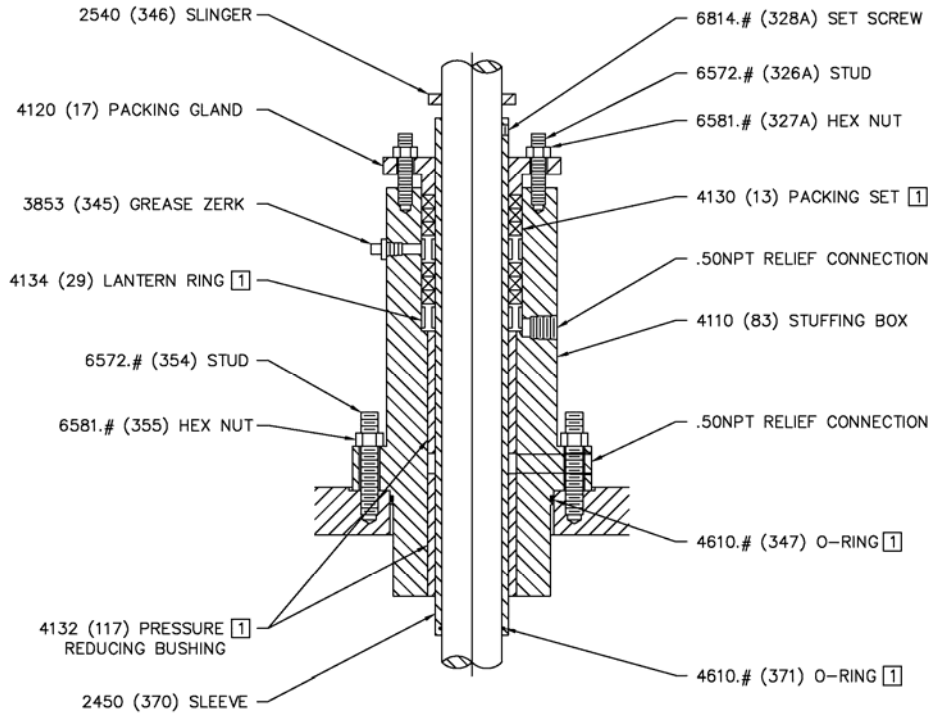

**3.3.8 Mechanical shaft seal**

VTP's can also be fitted with a mechanical seal. The requirement to fit the mechanical seal to be provided at the time of contract.

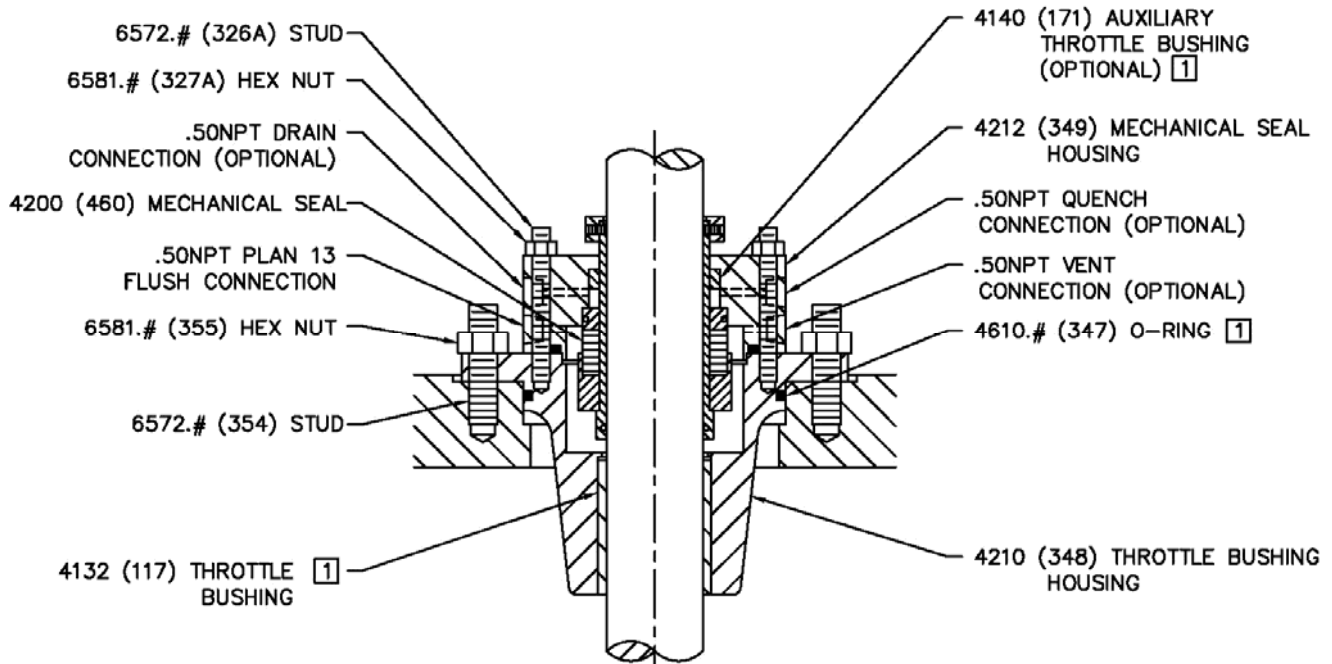

**3.3.8 Accessories**

Accessories may be fitted when specified by the customer.

**3.4 Performance and Operation Limits**

This product has been selected to meet the specifications of the purchase order. See section 1.5.

The following data is included as additional information to help with the installation. It is typical and factors such as temperature, materials and seal type may influence this data. If required, a definitive statement for your particular application can be obtained from Flowserve.

**3.4.1 Operating limits**

|                                   |                                 |
|-----------------------------------|---------------------------------|
| Pumped liquid temperature limits* | 5 °C (40 °F) to +80 °C (176 °F) |
| Maximum ambient temperature*      | Up to +40 °C (104 °F)           |
| Maximum pump speed                | refer to the nameplate          |

\*Subject to written agreement from Flowserve. Special designs and materials may be available for pumps operating above and below these specified limits. Contact Flowserve for upgrade options available for your specific application.

**4 INSTALLATION**



Equipment operated in hazardous locations must comply with the relevant explosion protection regulations. See section 1.6.4, *Products used in potentially explosive atmospheres*.

**4.1 Location**

When equipment has been in storage for greater than 6 months, a complete inspection should be conducted in accordance with section 2.4.3. The pump should be located to allow room for access, ventilation, maintenance and inspection with ample headroom for lifting and should be as close as practicable to the supply of liquid to be pumped. Refer to the general arrangement drawing for the pump set.

**4.1.1 Inspection prior to installation**

Six months prior to the scheduled installation date, a Flowserve Pump Division representative is to be employed to conduct an inspection of the equipment and the facility. If any deterioration of equipment is noticed, the Flowserve Pump Division representative may require a partial or complete dismantling of the equipment including restoration and replacement of some components.

**4.2 Preparation**

The pump should be located to allow room for access, ventilation, maintenance and inspection with ample headroom for lifting and should be as close as practicable to the supply of liquid to be pumped.

Refer to the general arrangement drawing for the pump dimensions and details.

**4.2.1 General installation check-list**

The following checks should be made before starting actual installation.

- a) Make sure that motor nameplate ratings and the power supply system match correctly.
- b) Check the sump depth and pump length match-up.
- c) Check the liquid level in the sump.
- d) Check the installation equipment to be sure that it will safely handle the pump weight and size.
- e) Check all pump connections (bolts, nuts etc) for any shipping and handling related problems.



Always support shafting in at least three places when lifting or installing. No installation should be attempted without adequate equipment necessary for a successful installation.



- On hollow shaft drivers, check the clutch size against the shaft size, which must go through the clutch
- On solid shaft drivers, check the motor shaft size against the coupling bore size



Apply thread lubricant sparingly to male shaft threads only at the time of making up shaft connection. Excess lubricant should be avoided.



Always check motor rotation before connecting driver to pump. Reverse rotation due to improper motor direction can cause extensive damage to the pump.

**4.3 Foundation/Anchor Bolts**



There are many methods of installing pump units to their foundations. The correct method depends on the size of the pump unit, its location and vibration limitations. Non-compliance with the

provision of correct foundation and installation may lead to failure of the pump and, as such, would be outside the terms of the warranty.

The foundation must consist of material that will afford rigid support to the discharge head and will absorb expected stresses that may be encountered in service.

Concrete foundations should have anchor bolts installed in sleeves that allow alignment and have holes in the mounting plate as illustrated in the detail below. Sleeve should be filled with non-bonding moldable material after sleeve is set in place.

When a suction barrel is supplied as in the case of the type "TF" discharge head, the suction vessel must provide permanent, rigid support for the pump and motor.

**CAUTION** All foundation / anchor bolt recommendations should be verified by prevailing industry standards.

Detail of a typical foundation bolt, grouted.

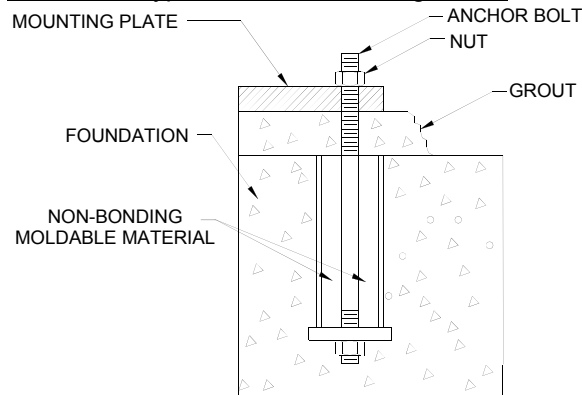

**4.3.1 Leveling of pumps mounted on the discharge head flange**

Example of a typical discharge head with the mounting flange

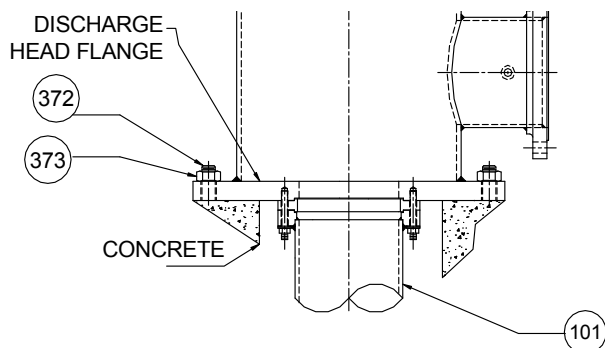

Some wet pit pumps are installed directly by using the flange that comes as an integral part of the discharge head. The pump is lowered into the pit and aligned with the anchor bolts [372].

The mounting flange is shimmed to achieve required level by using a precision machinist's level. **The pump is to be leveled to within 0.16 mm/m (0.002 in./ft).** The data to be recorded for future reference. Anchor bolt nuts [373] are tightened sufficient enough to hold down the pump in place.

Grout is poured and allowed to set for at least 72~80 hours (cure as required) before any further work is done on the pump.

**CAUTION** If leveling nuts are used to level the base, they must be backed off as far as possible prior to grouting.

Always shim near foundation bolts and then back off the leveling nuts. Now tighten the foundation bolts. If done otherwise there is a risk of significantly lowering the structural natural frequency that could result in separation of the base from the grout.

**Note:** Directly mounted pumps are not user friendly for service. Re-installation of these pumps requires re-leveling and re-grouting.

**4.3.2 Leveling of pumps mounted on a soleplate and the soleplate is grouted**

Some pumps are mounted on a separate plate known as soleplate [23]. In such cases, the level shall be set with a master level or a precision machinist's level. The mounting surface needs to be leveled to within 0.16 mm/m (0.002 in./ft).

The level should not exceed 0.125 mm (0.005 in.) elevation difference taken on any two points on the individual soleplate. Accurate shimming and grouting of the soleplate is very important. Record the leveling data for future reference. Grout the soleplate and allow to set at least 72~80 hours (cure as required) before the pump is lowered into the pit. Align the discharge head boltholes with the anchor bolts [372]. **Check and adjust the pump level to within 0.16 mm/m (0.002 in./ft)** with respect to the soleplate and torque the nuts [373] to the required level.

Example of pump mounted on a soleplate

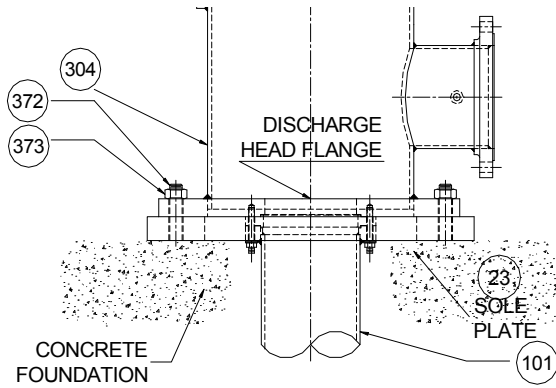

**4.3.3 Leveling of pumps with the suction barrel (also referred as “Can” VTPs)**

The suction barrel [315] is first lowered into the pit and aligned with the anchor bolts [372]. The suction barrel flange is leveled by using a master level or a precision machinist’s level. Levels should be taken on the equipment mounting surfaces. The suction barrel flange mounting surface needs to be leveled to within **0.16 mm/m (0.002 in./ft) using shims and grouted.** Allow the grout to set for at least 72~80 hours before the pump is installed. Check the barrel mounting surface level after the grout is set and then proceed with the pump installation. Lower the pump assembly into the pit and align the discharge head flange bolt holes to the anchor bolts [372].

Check and adjust the pump level with respect to the barrel flange to within **0.16 mm/m (0.002 in./ft)** and final torque the nuts [373]. The leveling data to be recorded for future reference.

Example of a pump installed with a suction barrel.

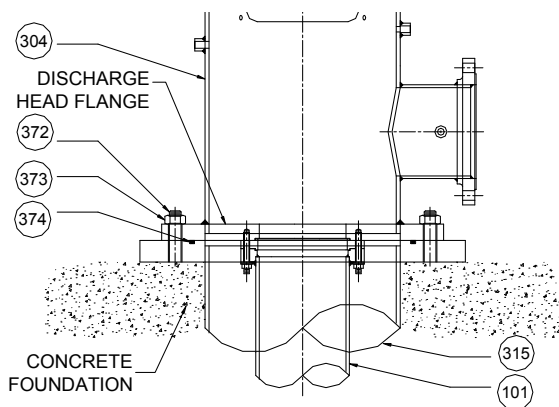

**4.3.4 Leveling of pumps with suction barrel mounted on a soleplate**

The soleplate [23] is installed on the foundation and aligned with the anchor bolts [372]. Level the soleplate with the help of a machinist’s level to within **0.16 mm/m (0.002 in./ft)**. Tighten the nuts [373] and grout. Cure and allow grout to set for 72~80 hours. Lower the suction barrel into the pit and level again with respect to the soleplate [23] to within **0.16 mm/m (0.002 in./ft)**. The level should not exceed 0.125 mm (0.005 in.) elevation difference taken on any two points on the soleplate. The pump [101] is now lowered into the suction barrel and installed. Make sure that the discharge head flange is still in level within **0.16 mm/m (0.002 in./ft)** with respect to the suction barrel [315].

Example of pump with a suction barrel mounted on a soleplate

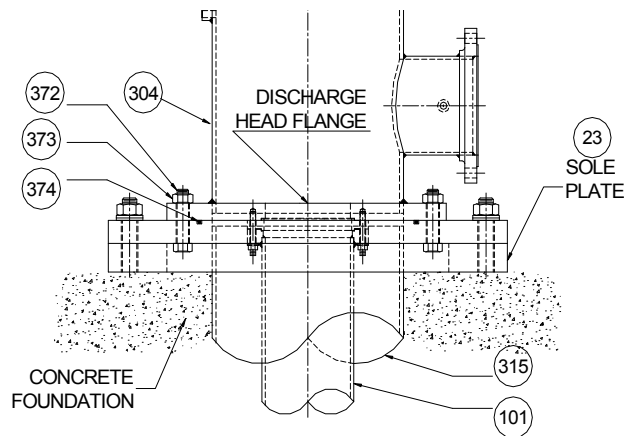

**4.4 Grouting**

Where applicable, grout in the foundation bolts. After adding pipe work connections and re-checking the coupling alignment, the mounting plate/soleplate should then be grouted in accordance with good engineering practice. If in any doubt, please contact Flowserve service center for advice.

Grouting provides solid contact between the pump unit and foundation that prevents lateral movement of running equipment and dampens resonant vibrations. Care should be taken to ensure maximum surface contact with grout between the pump base, sole plate, suction can and foundation (no voids).



Foundation bolts should only be fully tightened after the grout has been cured.



## 4.5 Lifting and Assembly

Motors may be supplied separately from the pumps. It is the responsibility of the installer to ensure that the motor is assembled to the pump and aligned as detailed in section 4.5. Discharge head column piping and the pump assembly are supplied either separately or as fully assembled depending upon the pump size and weight. If the parts are shipped separately, it is the customer's responsibility to install and align the pump with driver to the satisfaction of Flowserve's installation instructions.

### 4.5.1 Installation of pumps that are shipped unassembled

#### 4.5.1.1 Lifting

See lifting methods in section 2.3.

#### 4.5.1.2 Equipment and tools required for installation of unassembled pumps

The following list covers the principal tools/items required for installation.

- Two (2) mobile cranes capable of hoisting and lowering the pump and/or motor.
- Two (2) steel clamps of suitable size.
- Two (2) sets of chain tongs & cable sling for attaching to the pump and motor lifting eyes.
- Pipe clamp for lifting bowl assembly and the column pipe. Approximately 4.5 m (15 ft) of 19 mm (3/4 in.) diameter rope may be required.
- General purpose hand tools, pipe wrenches, end wrenches, socket set, screwdrivers, Allen wrenches, wire brush, scraper and fine emery cloth.
- Thread sealing compound designed for stainless steel and light machinery oil.

**Note:** Parts and accessories may be placed inside shipping containers or attached to skids in individual packages. Inspect all containers, crates and skids for attached parts before discarding.

#### 4.5.1.3 Uncrating and cleaning of unassembled pump

- Clean the parts of any dirt, packing material and other foreign matter.
- Flush the pump inside and outside with clean water. Clean all machined surfaces.
- Remove any rust spots found on the machined surfaces with fine emery cloth.
- Clean all threaded connections and any accessory equipment.



Lineshaft when shipped separately should be left in the crate to avoid damage or loss of straightness.

#### 4.5.1.4 Installing the bowl and column assembly

- Sump and piping should be thoroughly cleaned of all loose debris before starting installation.
- Check all bolts for tightness.
- Do not lift or handle the bowl assembly by the pump shaft.
- When installing bowl assemblies in sizes of 152 mm (6 in.) or 203 mm (8 in.), leave bowl securely fastened to the wooden skid that is attached for shipping until the bowl assembly is raised to a vertical position. This will help prevent breaking the bowls or bending the shaft.
- If a strainer is to be used, attach it to the bowl assembly using fasteners as necessary..
- Position lifting equipment so it will center over the foundation opening.
- If a base plate is used, level the plate to 0.16 mm per m (0.002 in. per ft) and then grout and anchor in place.
- Check for axial clearance or endplay and record that number for future reference (while bowls are in a horizontal position you should be able to push or pull the pump shaft indicating axial clearance).
- Carefully lift the suction barrel and the bowl assembly with suitable straps or clamps (See section 2.4 for lifting and safety rules).
- Lower the bowl assembly into the well or sump. Set clamp or holding device that is attached to bowls on a flat surface. This is to stabilize bowl assembly and reduce possibility of cross threading the shaft.
- Proceed to install the column assembly (refer to specific column pipe drawings).

#### 4.5.1.5 Installation of discharge head

Choose one of the following discharge head type installation procedure that is appropriate to the pump configuration that has been purchased

##### 4.5.1.5.1 Installation of discharge head with product lubrication

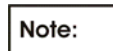

Pump head may be shipped with the sealing housing installed. For ease of assembly and to prevent damage, we recommend removing the housing before putting the head on the pump.

For pumps supplied with hollow shaft drivers and a one-piece headshaft (headshaft couples below sealing housing) proceed to step (a).

For pumps supplied with a two-piece headshaft (headshaft couples above the sealing housing) or solid shaft drivers, proceed to step (b) directly skipping step (a).

- a) Attach the headshaft to the lineshaft with a coupling and tighten (left hand threads).
- b) Lift discharge head over shaft and lower carefully into place (See section 2.3 for recommended lifting methods and safety instructions). Be sure not to bend the shaft. Fasten the top column flange and bearing retainer, if supplied to bottom of head. (Note that W heads do not have a bearing retainer at the top column flange).
- c) If baseplate is not included use shims or wedges between the pump and foundation to level the pump. The shaft must be centered in the discharge head.

See section 4.4.4 for coupling installation on solid shaft drivers and section 4.2.1~4.2.4 for pump leveling details

#### 4.5.1.5.2 Installation of discharge head with the enclosing tube

**Note:** Pump head may be shipped with the sealing housing installed. For ease of assembly and to prevent damage, we recommend removing the housing before putting the head on the pump.

For pumps supplied with hollow shaft drivers and a one-piece headshaft (headshaft couples below sealing housing) proceed to step (a). For pumps supplied with a two-piece headshaft (headshaft couples above the sealing housing) or solid shaft drivers, proceed to step (b) directly skipping step (a).

- a) Attach the headshaft to the lineshaft with a coupling and tighten (left hand threads).
- b) Attach the top enclosing tube to the column enclosing tube and tighten (left hand threads).
- c) Lift the discharge head over shaft and enclosing tube then lower carefully into place ( See section 2.3 for recommended lifting methods and safety instructions). Be sure, not to bend the shaft. Fasten the top column flange and alignment ring if supplied to bottom of head. (W heads do not have an alignment ring at the top column flange).
- d) Use shims or wedges between the pump and foundation to level the pump. The shaft must be centered in the discharge head.

See section 4.4.4 for coupling installation on solid shaft drivers and section 4.2.1~4.2.4 for pump leveling details.

#### 4.5.2 Installation of pumps that are shipped fully assembled

##### 4.5.2.1 Lifting

See lifting methods in section 2.3.

##### 4.5.2.2 Equipment and tools required for installation of a fully assembled pump

- a) Mobile crane capable of hoisting and lowering the entire weight of the pump and motor.
- b) Cable slings for attaching to the pump and motor lifting eyes.
- c) Ordinary hand tools: Pipe wrenches, end wrenches, socket set, screwdrivers, Allen wrenches, wire brush, scraper and fine emery cloth.
- d) Thread sealing compound designed for type of connection and light machinery oil.

**Note:**

The single most common cause of pump vibration is from a bent shaft. Shafting is straightened to stringent tolerances prior to shipping and great care must be exercised in its handling.

Always support shafting in at least three places when lifting or installing.

**CAUTION**

Parts and accessories may be placed inside shipping containers, or attached to skids in individual packages.

Inspect all containers, crates and skids for attached parts before discarding.

Lifting heavy objects is dangerous. Use of appropriate tools and procedures is must.

##### 4.5.2.3 Uncrating and cleaning of a fully assembled pump

- a) Clean the parts of all dirt, packing material and other foreign matter.
- b) Flush the pump inside and outside with clean water.
- c) Clean all machined surfaces. Remove any rust spots found on the machined surfaces with fine emery cloth.
- d) Clean all threaded connections and any accessory equipment.

**4.5.2.4 Installing the fully assembled pump**

If a base plate is used, level the plate to 0.16 mm per m (0.002 in. per ft), grout and anchor in place.

See sections 4.2.1~4.2.4 for pump leveling details.

Position lifting equipment so it will center over the foundation opening.

 Sump and piping should be thoroughly cleaned of all loose debris before starting installation.

Set up installation unit so that the lifting cable will be centered directly over the well or sump. Carefully lift the bowl assembly and suction barrel with a clamp. Lower the bowl assembly into the well or sump. Set the clamps or holding device that is attached to bowls on a flat surface. This is to stabilize bowl assembly and reduce possibility of cross threading the shaft.

- a) When installing 152 mm (6 in.) or 203 mm (8 in.) pump assembly, leave the pump securely fastened to the wooden skid (as shipped) until the bowl assembly is raised to a vertical position
- b) Lift the pump to a vertical position. If a strainer is used, attach it to the bowl assembly.
- c) Position pump over sump or suction barrel. Align the discharge of the pump with external piping then lower onto the base. Level the entire pump.
- d) If a stuffing box and a hollow shaft driver are included, attach the head shaft to the pump shaft (left hand threads).
- e) If a mechanical seal is included, install the seal at this point per the attached instructions.

If the pump includes a suction barrel (can), follow the procedure as listed below. (See lifting instructions in section 2.3)

- a) Install the suction barrel first and grout the mounting flange and bolts directly to the foundation.
- b) If soleplate is used, mount and grout the soleplate and mount the suction barrel onto the soleplate.
- c) Level the soleplate & the suction barrel flange as required.
- d) Check to ensure suction barrel is free of debris and other foreign material.
- e) Install the pump.

**4.5.3 Installation of couplings on solid shaft drivers.**

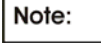
 If the pump purchased is having a solid shaft driver, one of the following coupling arrangement between the driver and the pump shaft is applicable. Choose the procedure appropriate to the coupling arrangement required.

 Clean threads on pump shaft and on adjusting nut. Check for burrs and nicks.

All burrs, nicks and rust must be removed from all mating parts of flanged coupling and pump before installation. Failure to remove all burrs, nicks and rust may result in misalignment causing pump to fail.

**4.5.3.1 Installation of adjustable flanged coupling WA/PA.**

- a) The key [46A] for the driver shaft keyseat should be a snug or tight fit in the shaft keyseat, and a sliding fit in the keyseat of the driver half coupling [42].
- b) The key with pin [46] should be a sliding fit in pump shaft keyseat and a snug or tight fit in pump half coupling [44] keyseat.
- c) Side clearance of keys in keyseats should be checked with a feeler gauge. Clearance for WA/PA coupling should not exceed 0.076 mm (0.003 in.) for a snug fit or 0.127mm (0.005 in) for a sliding fit. These are maximum allowable clearances. Closer fits are preferred, if possible. It may be necessary to file-dress keys to obtain proper fit.
- d) Insert the key [46] with pin into pump half of coupling [44] putting the pin in the hole in keyseat. The key should not extend below coupling.
- e) Lubricate pump coupling half and key assembly with light oil and slide it onto pump shaft [12A] with flange up. Slide it past threads.
- f) Lubricate adjusting nut [66A] with light oil and thread it onto pump shaft [12A] (left hand threads) with male register down. Thread it on until top of shaft and top of nut are even.
- g) Uncrate and lift driver to allow access to drive shaft.

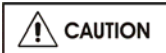
 The driver must be set on supports capable of carrying the entire weight of the driver before proceeding to step (h). Failure of supports could cause damage to the motor or loss of life.

- h) Clean and check driver shaft. Remove any burrs.

- i) Check the fit of the straight key and split thrust rings [312A] in their respective keyseats. (Refer to paragraph (a) regarding fit of the straight key).
- j) Install straight key into keyseat. The bottom of the key must be above the top of circular keyseat for the split thrust rings.
- k) Lubricate driver half coupling lightly and slide it onto driver shaft. Slide bottom of coupling above the top of the keyseat for split thrust rings.
- l) Install split thrust rings into circular keyseat and slide the coupling down over them.
- m) Tighten the coupling bolts as follows.

| Coupling bolts tightening torques |                                   |                    |
|-----------------------------------|-----------------------------------|--------------------|
| Coupling size                     | Flange diameter mm (in.)          | Torque N·M (In·lb) |
| 1 & 2                             | 112 & 137 (4.4 & 5.4)             | 121.5 (1075)       |
| 3, 4 & 5                          | 156, 188, & 213 (6.1, 7.4, & 8.4) | 237.0 (2100)       |
| 6                                 | 251 (9.9)                         | 424.0 (3750)       |

Torque values are for standard fasteners lubricated with a high stress lubricant (such as, graphite and oil, moly-disulphite, white lead etc.). For stainless steel bolts, multiply listed torques by 0.80.

- n) Proceed with the driver installation.

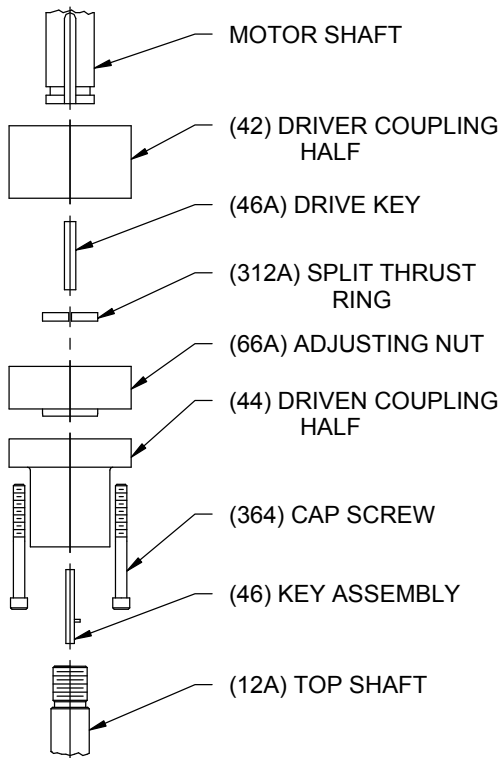

TYPE W/PA COUPLING DETAIL

4.5.3.2 **Installation of adjustable flanged spacer coupling WSA/PSA.**

Follow procedure from (a) thru (l) as listed in section 4.5.4.1.

- c) Bolt spacer [314] to the driver half coupling [42] using the short set of socket head cap screws [364]. The male register should be pointing down. Tighten all cap screws evenly to the bolt torques as listed in 4.5.4.1 under item (m).
- d) Proceed with the driver installation.

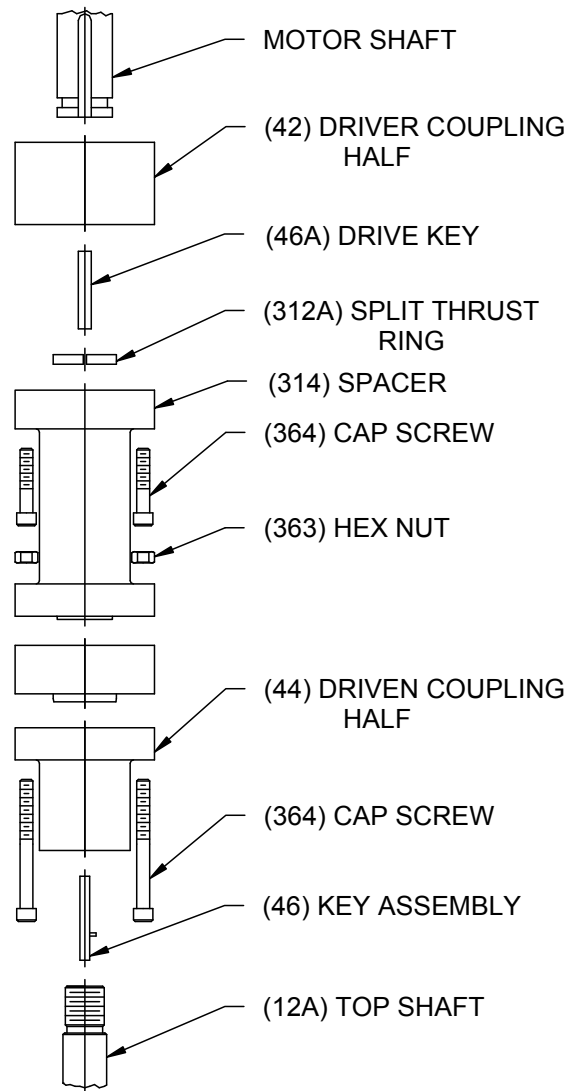

TYPE- WSA/PSA COUPLING DEATILS

**4.5.3.3 Installation of non-adjustable flanged coupling WNA/PNA.**

Follow procedure from (a) thru (e) as listed in section 4.5.4.1.

- f) Install one set of split thrust rings [312A] in to the circular keyway in pump shaft. Pull up the pump half of the coupling [44] over the split keys.
- g) Slide driver half coupling [42] onto driver shaft in the same manner as the pump half of the coupling.
- h) Set the spacer ring [314] between the two halves of the coupling together. Tighten all cap screws [364] evenly to the bolt torques as listed in 4.5.4.1 under item (m).
- i) Proceed with the driver installation.

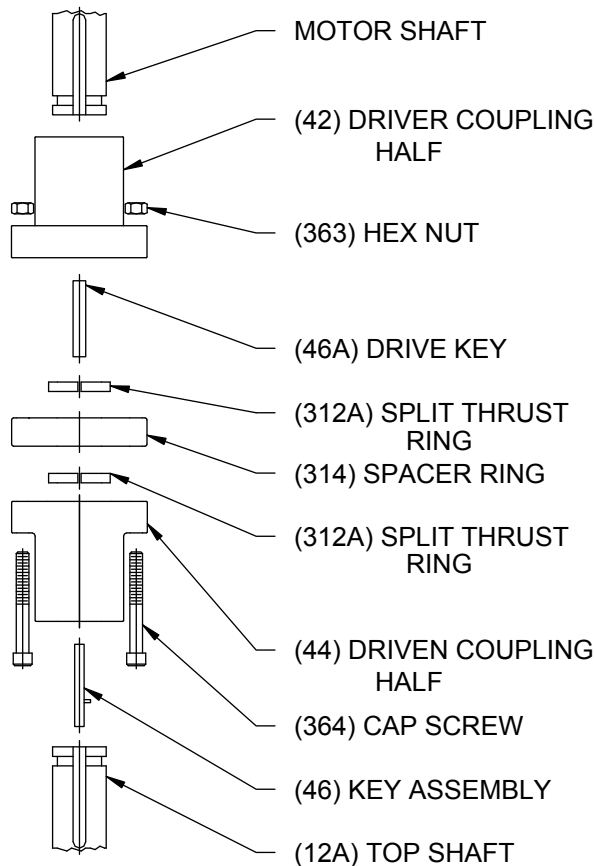

TYPE-WNA/PNA COUPLING DETAILS

**4.5.4 Installation of drivers**

**Note:**

Drivers will come with either hollow shaft or solid shaft as specified on the order/contract. Choose the correct installation procedure from the following paragraphs.

**CAUTION**

Reverse rotation with the pump shaft connected can cause extensive damage to the pump. Always check rotation before connecting driver to pump.

**4.5.4.1 Installation of hollow shaft driver**

- a) Clean driver mounting flange on discharge head and check for burrs or nicks on the register and mounting face. Oil lightly.
- b) Remove driver clutch.
- c) See (j) regarding installation of motor guide bushing, if required.
- d) Lift driver and clean mounting flange, checking for burrs and nicks.
- e) Center motor over pump and rotate to align mounting holes.  
**Electric motors** - rotate junction box into desired position.  
**Gear Drives** - rotate input shaft into desired position.
- f) Lower carefully into place making certain that the female register on the driver mates over the male register on the pump.
- g) Bolt driver to discharge head.
- h) Check the driver manufacturer's instruction manual for special instructions including lubrication instructions and follow all "startup" directions.
- i) Electric motors should be checked for rotation at this time. Make certain the driver clutch has been removed. Make electrical connections and "bump" motor (momentarily start, then stop) to check rotation. **DRIVER MUST ROTATE COUNTERCLOCK-WISE** when looking down at top end of motor. To change the direction of rotation on a three-phase motor, interchange any two line leads. To change direction of rotation on a two phase motor, interchange the leads of either phase
- j) Some motors will be supplied with a "lower guide bushing" or "steady bushing" which is installed at the bottom of the motor to stabilize the shaft at this point. Some motor manufacturers mount this guide bushing before shipping while others will ship the guide bushing with instructions for field mounting.



- k) Check the packing slip to see if a guide bushing is required, if so, determine if the bushing is already mounted or not and proceed accordingly. Refer to motor instruction manual.
- l) Carefully install drive clutch on driver making sure that it fits down properly.
- m) Clean threads on top of head shaft and head shaft nut. Lubricate male threads lightly. Install head shaft.
- n) Install gib key [335] in clutch and shaft. This must be a sliding fit and may require filing and dressing. Do not force.
- o) Thread adjusting nut down on shaft until it bears against clutch. (Threads on 43 mm (1.68 in.) and larger head shaft adjusting nuts are left-handed and all others are right handed). Do not thread nut further at this time. See impeller adjusting instructions in section 5.3.

- e) Check driver manufacturer's instructions for special instructions including lubrication instructions and follow all "startup" instructions.
- f) Electric drivers should be checked for rotation at this time. Make electrical connections "bump" motor (momentarily start, then stop) to check rotation. DRIVER MUST ROTATE COUNTERCLOCKWISE when looking down at top end of motor. To change the direction of rotation on a three-phase motor, interchange any two line leads. To change direction of rotation on a two-phase motor, interchange the leads of either phase.
- g) See impeller adjustment instructions (section 5.3) before bolting the pump and driver half of the coupling together.

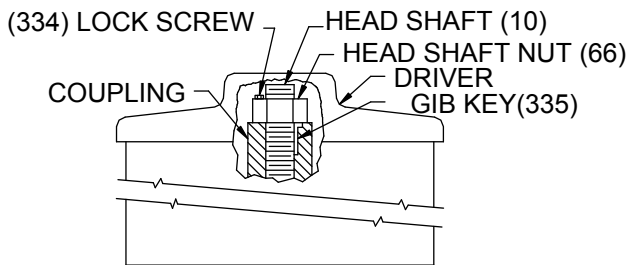

4.5.4.3 **Installation of solid shaft driver with jacking screws**

4.5.4.2 **Installation of solid shaft driver without jacking screws**

**CAUTION** When lowering the motor and driver half of coupling onto pump, do not let pump half of the coupling touch the driver half of the coupling.

Before bumping motor make sure coupling halves are not touching and that the driver can rotate freely, without rotating the pump

Driver half coupling must be in proper position so the circular key will not come out.

- a) Clean driver mounting flange on discharge head and check for burrs or nicks on the register and mounting face. Oil lightly.
- b) Center motor over pump and rotate to align mounting holes.  
**Electric motors:** Rotate junction box into desired position.  
**Gear Drives:** Rotate input shaft into desired position.
- c) Lower driver carefully into place making certain that the female register on the driver mates over the male register on the pump.
- d) Bolt driver to discharge head.

- a) Clean driver mounting flange on discharge head and check for burrs or nicks on the register and mounting face. Oil lightly.
- b) Center motor over pump and rotate to align mounting holes.  
**Electric motors:** Rotate junction box into desired position.  
**Gear Drives:** Rotate input shaft into desired position.
- c) Lower driver carefully into place. Mount the dial indicator base on the O.D. of the motor half coupling. Set the indicator on the pump shaft, position the dial to zero being careful that the indicator is in direct line with one of the jackscrews. Record this reading then rotate the motor shaft and indicator 180 degrees. Record this reading being careful to note plus or minus values. Take the difference of the two readings and using the jackscrews move the motor one-half of the difference. Repeat this step until the T.I.R. reading is a maximum of 0.051mm (0.002in.). Then repeat this step for the set of jack screws located 90 degrees to the first set. Once all readings are within 0.051mm (0.002in.), tighten motor bolts and check for any movement in readings.
- d) Check driver manufacturer's instructions for special instructions including lubrication instructions and follow all "startup" instructions.
- e) Electric drivers should be checked for rotation at this time. Make electrical connections and "bump" motor (momentarily start, then stop) to check rotation. DRIVER MUST ROTATE COUNTER-CLOCKWISE when looking down at top end of motor. To change the direction of rotation on a three-phase motor, interchange any

two line leads. To change direction of rotation on a two-phase motor, interchange the leads of either phase.

- f) See impeller adjustment instructions (section 5.3 before bolting the pump and driver half of the coupling together.

## 4.6 Initial Alignment

### 4.6.1 Thermal expansion

**CAUTION** The pump and motor will normally have to be aligned at ambient temperature and should be corrected to allow for thermal expansion at operating temperature. In pump installations involving high liquid temperatures greater than 300°F, the unit should be run at the actual operating temperature, shut down and the alignment checked immediately.

### 4.6.2 Preparation before alignment

To ensure proper alignment the following items are very important.

- a) All machined mating surfaces (such as the mating flanges of pump and motor) must be clean and free of burrs and nicks.
- b) Exterior strain must not be transmitted to the pump. The most common cause of trouble is forcing the piping to mate with the pump. It is recommended that flexible connectors be installed in the piping adjacent to the pump.
- c) All threads should be checked for damage and repaired if necessary. Lubricate all threaded connections with a suitable thread lubricant (an anti-galling compound).

### 4.6.3 Alignment methods

**DANGER** Ensure pump and driver are isolated electrically and the half couplings are disconnected.

**CAUTION** The alignment MUST be checked. Although the pump will have been aligned at the factory it is most likely that this alignment will have been disturbed during transportation or handling. If necessary, align the motor to the pump, not the pump to the motor.

**Note:** Adding or removing shims between the motor and the discharge head helps alignment in the vertical direction. The motor assembly may also have to be adjusted in the horizontal direction to line up the driver and shaft centers. Alignment screws

are provided to lock the motor assembly in its final aligned position.

See section 5.3.2.1 for final coupling alignment for solid shaft.

**Note:** Before bumping motor make sure that the coupling halves are not touching and that the driver can rotate freely without rotating the pump. Driver half coupling must be in proper position so the circular key will not come out.

### 4.6.4 Angular and parallel misalignment

**CAUTION** Check the direction of pump rotation before the coupling is fully connected. The power supply to the driver to be connected only after the final alignment is complete.

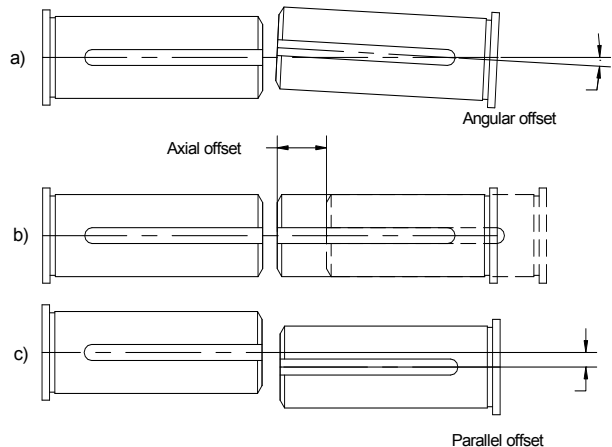

- a) **Angular Offset:** The median lines of shaft intersect halfway between the ends of the two shafts.
- b) **Axial Offset:** Another offset is the displacement of one or both of the shafts. A typical example is thermal expansion.
- c) **Parallel Offset:** The median lines run parallel. The maximum allowable parallel offset depends on the size of coupling and is indicated in the instruction manual of manufacturer of coupling.

For couplings with narrow flanges use a dial indicator as shown in the detail to check both parallel and angular alignment.



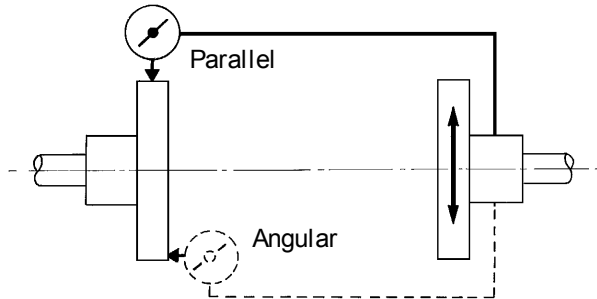

**Note:**

- a) Pumps with thick flanged non-spacer couplings can be aligned by using a straight-edge across the outside diameters of the coupling hubs and measuring the gap between the machined faces using feeler gauges, measuring wedge or calipers.
- b) When the electric motor has sleeve bearings, it is necessary to ensure that the motor is aligned to run on its magnetic centerline.



Refer to the motor User Instructions for details.

**CAUTION**

If the motor does not run in its magnetic center the resultant additional axial force may overload the pump thrust bearing.

If the pump is handling hot liquid, the alignment must be rechecked in warm condition of the unit. The alignment of the unit shall be checked again after 200 service hours.

**4.7 Piping**

**CAUTION**

Protective covers are fitted to the pipe connections to prevent foreign particles or objects entering the pump during transportation and installation. Ensure that these covers are removed from the pump before connecting pipes.

**4.7.1 Pipe work velocities**

In order to minimize friction losses and hydraulic noise in the pipe work it is good practice to choose pipe work that is one or two sizes larger than the pump suction and discharge.

Typically, main pipe velocities should not exceed 2 m/s (6 ft/sec) on the suction and 3 m/s (9 ft/sec) on discharge.

Take into account the available NPSH that must be higher than the required NPSH of the pump.

**CAUTION**

Never use the pump as a support for piping.

**4.7.2 Maximum forces and moments allowed on VTP pump flanges (See table 4.6.2.1)**

Maximum forces and moments allowed on the pump flanges vary with the pump size and type. To minimize these forces and moments that may, if excessive, cause misalignment, hot bearings, worn couplings, vibration and possible failure of the pump casing. The following points should be strictly followed.

- a) Prevent excessive external pipe load.
- b) Never draw piping into place by applying force to pump flange connections.
- c) Do not mount expansion joints so that their force, due to internal pressure, acts on the pump flange.

**CAUTION**

Ensure piping and fittings are flushed before use.



Ensure that the piping arrangement has been provided to flush the pump before removal in cases of hazardous liquid pumps.

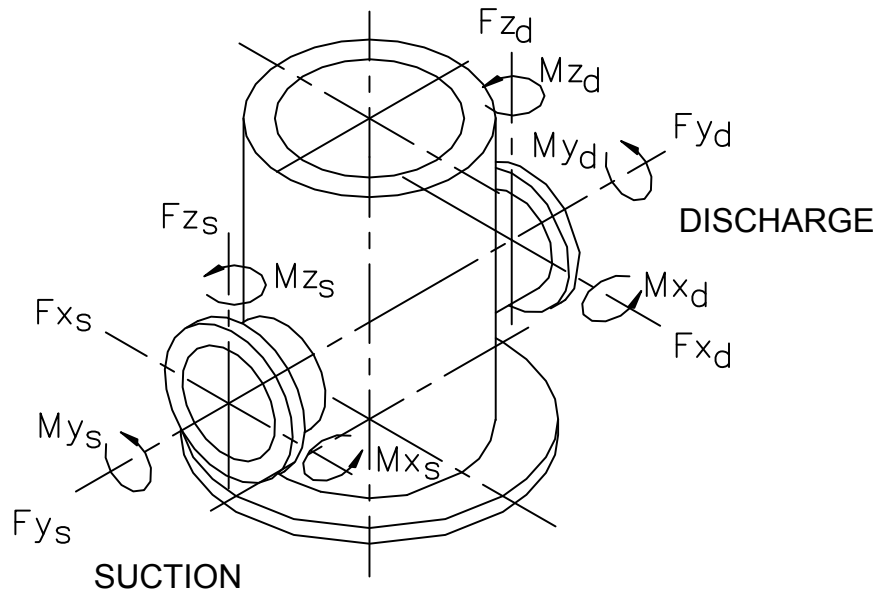

4.7.2.1 Table of maximum forces and moments allowed on VTP pump flanges

| Head Type         | Forces & Moments | Discharge Head Size mm(in.)        |             |             |             |             |             |             |             |             |             |             |             |
|-------------------|------------------|------------------------------------|-------------|-------------|-------------|-------------|-------------|-------------|-------------|-------------|-------------|-------------|-------------|
|                   |                  | 100 (4)                            | 150 (6)     | 200 (8)     | 255 (10)    | 305 (12)    | 355 (14)    | 400 (16)    | 460 (18)    | 508 (20)    | 610 (24)    | 760 (30)    | 915 (36)    |
| W                 | Fx               | 0.53 (120)                         | 0.80 (180)  | 1.13 (255)  | 1.47 (330)  | 1.67 (375)  | 1.78 (400)  |             |             |             |             |             |             |
|                   | Fy               | 0.67 (150)                         | 1.00 (225)  | 1.47 (330)  | 1.83 (410)  | 2.00 (450)  | 2.23 (500)  |             |             |             |             |             |             |
|                   | Fz               | 0.45 (100)                         | 0.67 (150)  | 0.94 (210)  | 1.22 (275)  | 1.34 (300)  | 1.45 (325)  |             |             |             |             |             |             |
|                   | Mx               | 0.50 (370)                         | 0.75 (550)  | 1.06 (780)  | 1.37 (1015) | 1.52 (1125) | 1.59 (1175) |             |             |             |             |             |             |
|                   | My               | 0.26 (190)                         | 0.39 (285)  | 0.53 (390)  | 0.67 (495)  | 0.74 (550)  | 0.78 (575)  |             |             |             |             |             |             |
|                   | Mz               | 0.37 (275)                         | 0.57 (425)  | 0.77 (570)  | 1.04 (770)  | 1.15 (850)  | 1.18 (875)  |             |             |             |             |             |             |
| HF & LF           | Fx               | 1.07 (240)                         | 1.60 (360)  | 2.27 (510)  | 2.94 (660)  | 3.34 (750)  | 3.56 (800)  | 4.23 (950)  | 4.90 (1100) | 5.34 (1200) | 6.01 (1350) | 7.12 (1600) | 8.46 (1900) |
|                   | Fy               | 1.34 (300)                         | 2.00 (450)  | 2.94 (660)  | 3.65 (820)  | 4.00 (900)  | 4.45 (1000) | 5.12 (1150) | 5.79 (1300) | 6.23 (1400) | 7.12 (1600) | 8.46 (1900) | 9.79 (2200) |
|                   | Fz               | 0.89 (200)                         | 1.36 (300)  | 1.87 (420)  | 2.45 (550)  | 2.67 (600)  | 2.89 (650)  | 3.34 (750)  | 4.00 (900)  | 4.45 (1000) | 4.90 (1100) | 5.56 (1250) | 6.23 (1400) |
|                   | Mx               | 1.00 (740)                         | 1.49 (1100) | 2.11 (1560) | 2.75 (2030) | 3.05 (2250) | 3.18 (2350) | 3.66 (2700) | 4.06 (3000) | 4.47 (3300) | 5.42 (4000) | 6.50 (4800) | 7.60 (5600) |
|                   | My               | 0.51 (380)                         | 0.77 (570)  | 1.06 (780)  | 1.34 (990)  | 1.49 (1100) | 1.56 (1150) | 1.83 (1350) | 2.03 (1500) | 2.51 (1850) | 2.71 (2000) | 3.25 (2400) | 3.80 (2800) |
|                   | Mz               | 0.75 (550)                         | 1.15 (850)  | 1.54 (1140) | 2.09 (1540) | 2.30 (1700) | 2.37 (1750) | 2.71 (2000) | 3.05 (2250) | 3.39 (2500) | 4.07 (3000) | 4.88 (3600) | 5.70 (4200) |
| TF <sup>(1)</sup> | Fx               | 1.07 (240)                         | 1.60 (360)  | 2.27 (510)  | 2.94 (660)  | 3.34 (750)  | 3.56 (800)  | 4.23 (950)  | 4.90 (1100) | 5.34 (1200) | 6.00 (1350) | 7.12 (1600) |             |
|                   | Fy               | 1.34 (300)                         | 2.00 (450)  | 2.94 (660)  | 3.65 (820)  | 4.00 (900)  | 4.45 (1000) | 5.12 (1150) | 5.79 (1300) | 6.23 (1400) | 7.12 (1600) | 8.46 (1900) |             |
|                   | Fz               | 0.89 (200)                         | 1.34 (300)  | 1.87 (420)  | 2.45 (550)  | 2.67 (600)  | 2.89 (650)  | 3.34 (750)  | 4.00 (900)  | 4.45 (1000) | 4.90 (1100) | 5.56 (1250) |             |
|                   | Mx               | 1.00 (740)                         | 1.49 (1100) | 2.11 (1560) | 2.75 (2030) | 3.05 (2250) | 3.18 (2350) | 3.66 (2700) | 4.07 (3000) | 4.47 (3300) | 5.42 (4000) | 6.50 (4800) |             |
|                   | My               | 0.51 (380)                         | 0.77 (570)  | 1.06 (780)  | 1.34 (990)  | 1.49 (1100) | 1.56 (1150) | 1.83 (1350) | 2.03 (1500) | 2.51 (1850) | 2.71 (2000) | 3.25 (2400) |             |
|                   | Mz               | 0.75 (550)                         | 1.15 (850)  | 1.54 (1140) | 2.09 (1540) | 2.30 (1700) | 2.37 (1750) | 2.71 (2000) | 3.05 (2250) | 3.39 (2500) | 4.07 (3000) | 4.88 (3600) |             |
| UF                | Fx               | CONTACT FLOWSERVE CUSTOMER SERVICE |             |             |             |             |             |             |             |             |             |             |             |
|                   | Fy               |                                    |             |             |             |             |             |             |             |             |             |             |             |
|                   | Fz               |                                    |             |             |             |             |             |             |             |             |             |             |             |
|                   | Mx               | CONTACT FLOWSERVE CUSTOMER SERVICE |             |             |             |             |             |             |             |             |             |             |             |
|                   | My               |                                    |             |             |             |             |             |             |             |             |             |             |             |
|                   | Mz               |                                    |             |             |             |             |             |             |             |             |             |             |             |

Units: Force (F) in kN (lbf); Moments (M) in kNm (lbf-ft)

1. Forces and moments shown for TF head are for the discharge flange. For the suction flange, use the values for the next large size head.

Loads shown are maximum allowable for standard construction. Contact Flowserve if higher values are required or temperatures are higher than ambient

### 4.7.3 Auxiliary piping

#### 4.7.3.1 Drains

Normal pump leaks and gland leakage to be drained through a separate piping arrangement or back into the suction/sump.

#### 4.7.3.2 Pumps fitted with gland packing

The pumped liquid is allowed to flow through the gland packing at discharge pressure and drained out of the pump or re-circulated back into the suction. A separate flush supply may be required in some cases. The piping plans and flush supply are to be selected based on the application and operating parameters.

In some special cases where the discharge pressure exceeds 6.5 bar (100 psi) a special flushing plan is recommended.

#### 4.7.3.3 Pumps fitted with mechanical seals

Auxiliary piping to circulate the flushing liquid back into the suction is required. In case of external clean source requirements for pump applications such as high temperature service, contaminated fluids, oxidizing fluids, a special piping plan to carry the clean liquid into the seal chamber with adequate pressure is required and several piping plans are available to suit the specific pump application.

 See section 5.4 for *Direction of rotation* before connecting motor to the power supply.

#### 4.7.4 Final checks

After connecting the piping to the pump, rotate the shaft several times by hand to ensure no pipe strain. If pipe strain exists, correct piping.

### 4.8 Electrical Connections

 **DANGER** Electrical connections must be made by a qualified Electrician in accordance with relevant local national and international regulations.

 It is important to be aware of the EUROPEAN DIRECTIVE on potentially explosive areas where compliance with IEC60079-14 is an additional requirement for making electrical connections.

 It is important to be aware of the EUROPEAN DIRECTIVE on electromagnetic compatibility when wiring up and installing equipment on site. Attention must be paid to ensure that the techniques used during wiring/installation do not increase electromagnetic emissions or decrease the electromagnetic immunity of the equipment, wiring or

any connected devices. If in any doubt contact Flowserve for advice.

 **DANGER** The motor must be wired up in accordance with the motor manufacturer's instructions (normally supplied within the terminal box) including any temperature, earth leakage, current and other protective devices as appropriate. The identification nameplate should be checked to ensure the power supply is appropriate.

 A device to provide emergency stopping must be fitted.

If not supplied pre-wired to the pump unit, the controller/starter electrical details will also be supplied within the controller/starter.

For electrical details on pump sets with controllers see the separate wiring diagram.

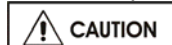
 See section 5.4, *Direction of rotation* before connecting the motor to the electrical supply.

### 4.9 Final Shaft Alignment Check

After connecting piping to the pump, rotate the shaft several times by hand to ensure there is no binding and all parts are free. Recheck the coupling alignment, as previously described, to ensure no pipe strain. If pipe strain exists, correct piping.

### 4.10 Protection Systems

 The following protection systems are recommended particularly if the pump is installed in a potentially explosive area or is handling a hazardous liquid. If in doubt, consult Flowserve.

If there is any possibility of the system allowing the pump to run against a closed valve or below minimum continuous safe flow a protection device should be installed to ensure the temperature of the liquid does not rise to an unsafe level.

If there are any circumstances in which the system can allow the pump to run dry, or start up empty, a power monitor should be fitted to stop the pump or prevent it from being started. This is particularly relevant if the pump is handling a flammable liquid.

If leakage of product from the pump or its associated sealing system can cause a hazard it is recommended that an appropriate leakage detection system is installed.

To prevent excessive surface temperatures at the bearings, it is recommended that temperature and/or vibration monitoring is done on a regular basis.

## 5 COMMISSIONING, STARTUP, OPERATION AND SHUTDOWN

 **CAUTION** These operations must be carried out by fully qualified personnel. Turn off power supply for safety while pump commissioning is in progress.

### 5.1 Pre-commissioning Procedure

The gland is to be filled with grease and flush supply to be in place. Flush piping to be checked for leaks. Mechanical seals to be checked for leaks, flush flow and pressure.

- a) Pumps with the enclosing tubes and oil-lubed bearings must be filled with the proper lubricant to avoid running dry and to guarantee acceptable performance of the pump. A separate oil tank is attached to the pump (see detail in section 5.2.2).
- b) For can pumps check all vent connections for complete filling of the pump. The venting procedure can take from 10 minutes up to 2 hours, depending on the kind of fluid .
- c) Check the direction of rotation of the pump (Coupling spacer dismantled). Should be counter clockwise when viewed from the driver end.
- d) The pump rotor and the shaft seal must be in correct axial position.
- e) Check the readiness of all auxiliary systems (seal sys., lubrication system etc.,) for startup.
- f) All pipe work, including the internal and the auxiliary pipe work, must be connected correctly and must be absolutely tight. Check the tightness of all connections of the auxiliary pipe work. The suction valve must be open, the discharge valve shall be closed or partially open as required.
- g) Turn the pump by hand, if required with the help of a lever, to check the free rotation of the rotor. The rotor must turn uniformly and noiselessly. Some resistance may be felt due to the friction in the bearings and seals.
- h) Check the readiness of the driver for startup. Refer to the manual for the driver to be sure that all precautions are in place to energize the motor.

### 5.2 Pump Lubricants

Other than the stuffing box lubrication, mechanical seal and/or lineshaft lubrication, the pump will not require further periodic lubrication. On water pumps, the suction bearing on the bowl assembly should be repacked when required. Pumps that pump hydrocarbons or have carbon, rubber, epoxy or Teflon suction bearings do not have the suction bearings packed. If the pump will be started after a longer storage period, the bearings should be first flushed and cleaned by using a suitable cleaning agent. It is not necessary to remove the oil sprayed for short or long-term storage as this will mix up thoroughly with the lubrication oil.

**Note:** Re-checking the motor lubrication should be in accordance with the motor manufacturer's user instructions supplied separately with the pump.

#### 5.2.1 Open lineshaft lubrication

Open lineshaft bearings are lubricated by the pumped fluid where the static water level is less than 9 m (30 ft) below the discharge head and will usually not require pre or post-lubrication. Care is to be taken to ensure that the gland or seal is supplied with the required flush flow.

All open lineshaft pumps where the static water level is more than 9 m (30 ft) below the discharge head should be adequately pre-lubricated before starting the pump.

##### 5.2.1.1 Pre-lubrication duration

Allow flush water to flow down the shaft for 45 minutes for pumps over 9 m (30 ft) and increase the pre-lube duration by at least 15 minutes for every 5 m (15 ft) additional shaft length beyond 20 m (65 ft). The fittings for pre-lube are provided at the discharge head.

##### 5.2.1.2 Typical pre-lube pipe connection (examples (a) thru (d))

In general all W type cast discharge heads are provided with a standard size pipe fitting for pre-lube connection. Fabricated discharge heads are fitted with a special piping arrangement to allow pre-lube liquid flow onto the shaft.

**Note:** It is the responsibility of the user to install a reliable pre-lube system to achieve the pump pre-lubrication. Flowserve will not supply these types of systems or accessories with the pump.

Examples of typical pre-lube methods used in the industry are as follows.

Example (a)

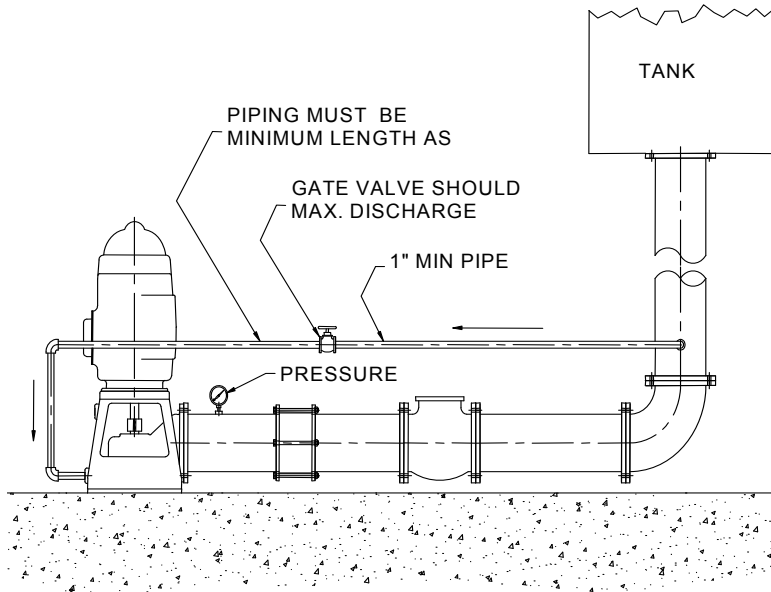

Pre-lubrication recommended tank volume for pumps started at rated RPM's for all cases of pre-lubrication methods suggested in this section

| Depth to water level<br>(at the time of starting the<br>pump) m (ft) |           | Pre-Lubrication tank<br>size.m <sup>3</sup> (US gal) |
|--|-----------|--|
| More than  | Upto      |  |
| 0  | 9 (30)    | 0  |
| 9 (30)   | 30 (100)  | 0.19 (50)  |
| 30 (100)   | 60 (200)  | 0.38 (100)   |
| 60 (200)   | 150 (500) | 0.75 (200)   |

Example (b)

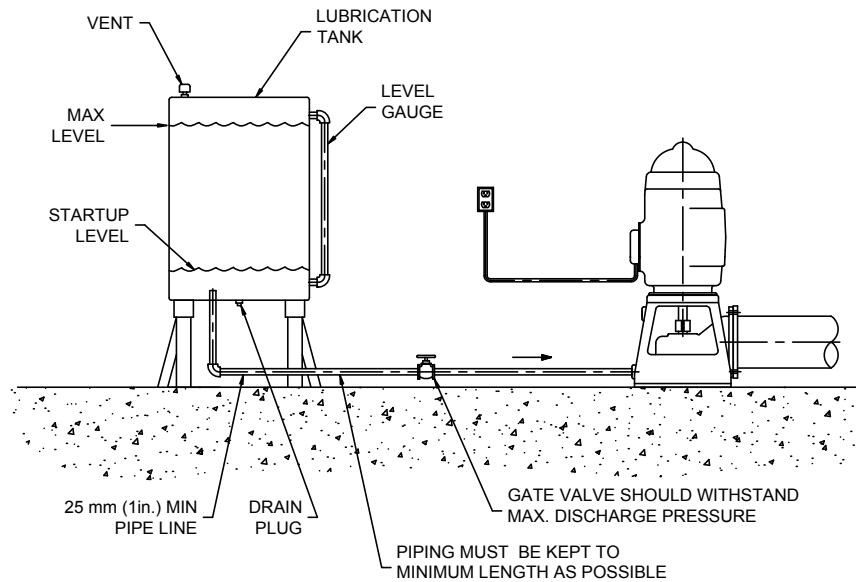



Example (c)

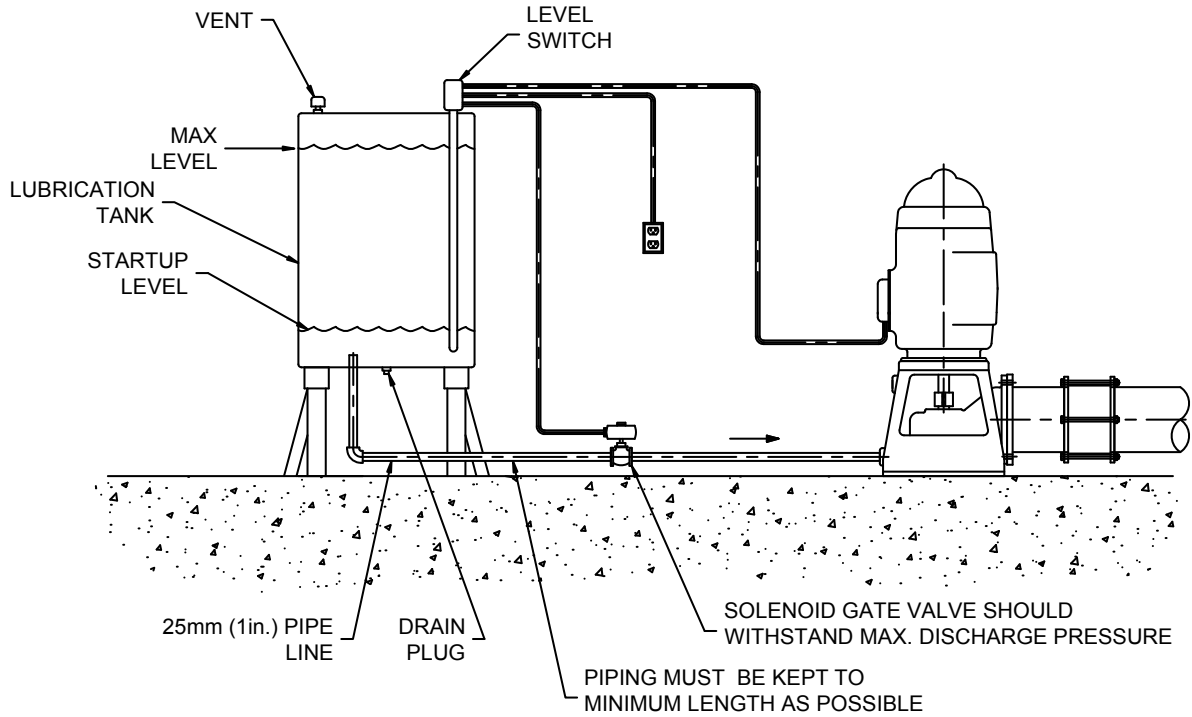

Example (d)

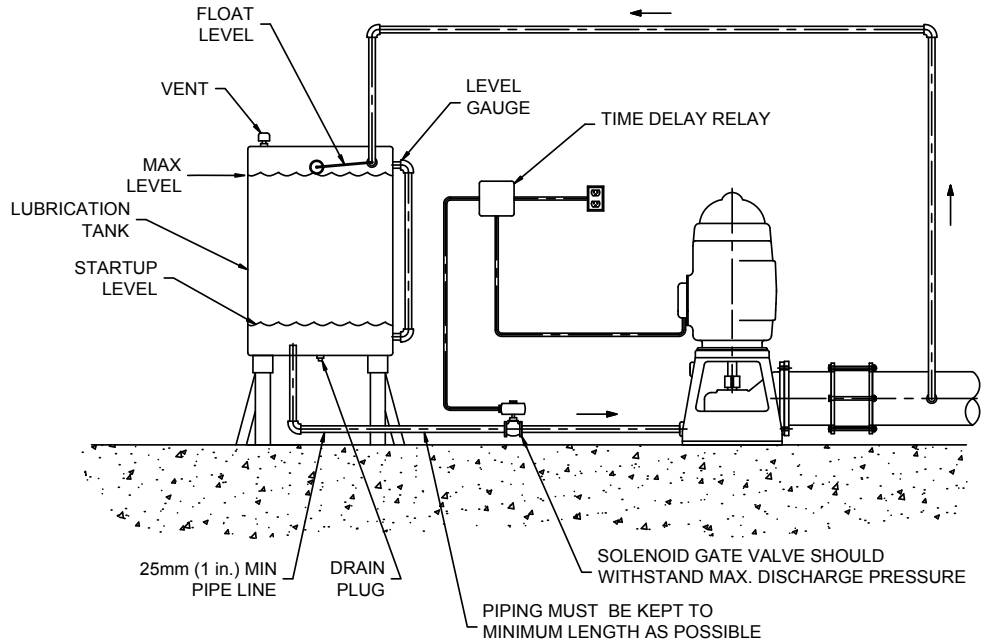

**5.2.2 Enclosed shaft lubrication**

VTPs with the enclosed shafting are lubricated by a dedicated oil supply system or injection lubricated by extraneous liquid; usually clean water to meet the application requirements.

**5.2.2.1 Oil lubricated pumps**

The lubricating oil must be available and should be allowed to run into the enclosing tube in sufficient quantity to thoroughly lubricate all lineshaft bearings. The gravity flow system is the most commonly utilized system for oil.

The oil reservoir (example shown in detail below) must be kept filled with a good quality light turbine oil (about 30 cSt) at the operating temperature and adjusted to feed a minimum of 3 drops per minute per 30 m (100 ft) of column length, at never less than 5 drops per minute total.

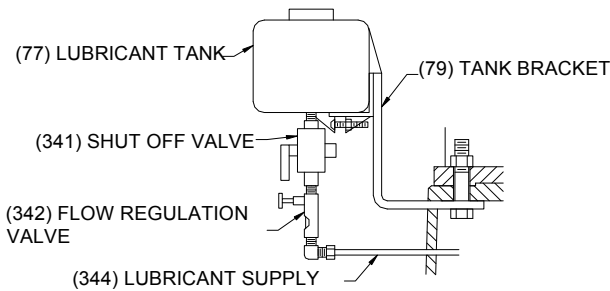

**5.2.2.2 Pre-lubrication of oil lubricated pumps**

As a general rule, the oil must be allowed to flow by gravity at least 45 minutes before the pump is started for the first time or in case the pump was turned off for a longer duration. Adequate care should be taken to make sure that the flow is available and is consistent for subsequent startups.

**5.2.2.3 Injection lubricated pumps**

Enclosed lineshaft bearings are lubricated by extraneous liquid (usually clean water), which is fed to the tension nut either by gravity flow, or by a pressure injection system.

**Note:** Injection systems are designed for each installation. Injection pressure and quantity of liquid will vary. Normally 0.45-0.90 m<sup>3</sup>/h (2-4 gpm) at 0.7-1.4 bar (10-20 psi) over maximum pump discharge pressure of clean liquid is required.

**5.2.2.4 Pre-lubrication of injection lubricated pumps**

As a general rule, the liquid flow is to be started at least 15~20 minutes before the pump is started for the first time or in the event of pump not being in use for longer duration.

The injected lubricant flow is never stopped for short 'off' periods. Adequate care should be taken to make sure that the flow is available and consistent for subsequent startups and operation. Injection pressure to be adjusted as recommended before the startup.

**5.2.3 Enclosed shaft lubricants**

The following oils are recommended for enclosed lineshaft bearing lubrication under normal operating conditions. See tables 5.2.3.1 and 5.2.3.2.



It is recommended that detergent type oils not be used.

**5.2.3.1 Non-food/food grade lubricant oils**

Equivalent turbine oil (food or non-food grades as required) with the matching properties has to be selected. Oils with a viscosity range of 30 cSt (mm<sup>2</sup>/sec) to 37 cSt (mm<sup>2</sup>/sec) at 40 °C (100 °F) with a minimum viscosity index of 90 are recommended.

The pour point of the oil must be in accordance with the lowest expected temperature of the bearing housing during a stop of the pump.

**5.2.4 Oil level**

The correct oil level is in the middle of the oil sight glass and shall be checked when the pump is not in operation. Periodically check if the lubricating oil is mixed with any condensed water. Careful opening of the oil drain during a stop of the pump will show any water.

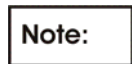

After the initial start the level will decrease due to circulation of the oil through the bearings.



If the oil level is higher than specified, it could result in higher bearing temperatures resulting in poor lubrication.

**5.3 Impeller Adjustment**

Proper impeller adjustment positions the impeller inside the bowl assembly for maximum performance. The impellers must be raised slightly to prevent them from dragging on the bowls, but not raised too high so as to adversely affect hydraulic performance.

The impeller must be down against the bowl seat when starting impeller adjustment. When pumps are subjected to suction pressure, the pressure acting against the shaft tends to raise it. Make sure the shaft is down when starting to adjust the impellers.

If, after making the impeller adjustment the pump does not deliver its rated capacity, the impellers can be lowered one step at a time until the lowest possible adjustment is achieved without the impellers dragging. On the other hand, if the impellers appear to be dragging after the initial adjustment, the unit should be stopped and the impellers raised one step. Dragging impellers will increase the load significantly and can usually be heard and felt as increased vibration. A sharp rise in motor amperage will occur when impellers are dragging.

**5.3.1 Impeller adjustment for a hollow shaft driver**

Impeller adjustment when using hollow shaft drivers is as follows. The driver canopy will have to be removed before beginning.

- a) Install headshaft [10] if not already in place.
- b) Install driver clutch in accordance with the driver instruction manual and bolt into place.
- c) Check shaft position. Lower shaft until there is a definite feel of metal contacting metal. This indicates the impellers are "on bottom" and in the correct starting position for impeller adjustment.
- d) Thread headshaft nut [66] down (right hand threads) except 43 mm (1.7 in.) and larger sizes that are having left hand threads, until impellers are just raised off their seat and the shaft will rotate freely.
- e) Check a separate document that is supplied with the pump that provides recommended impeller setting and running clearance information..

Detail showing head shaft and lock screw arrangement

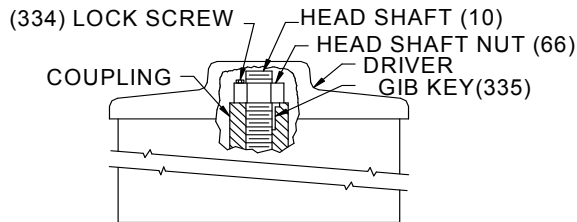

**Note:** If at any time during the life of this pump the pumping conditions or total pump length changes, contact the factory for recalculation of the impeller setting.

- f) Tighten the adjusting nut to match impeller setting recommended by Flowserve. See table 5.3.1.1 & 5.3.1.2.

- g) Using the cap screw provided, bolt the headshaft nut [66] down & lock using lock screw [334] to the motor coupling. See the details of head shaft and lock screw arrangement under item (h) below.



Always lock headshaft nut by tightening the lock screw [334] before starting driver. Failure to do so could result in damage to the pump and driver.

- h) If a mechanical seal is used, adjust the mechanical seal at this time.

**5.3.1.1 Impeller clearance settings**

Flowserve recommends the following impeller settings based on the pump sizes.

| If the pump size is | Setting for enclosed impellers | Setting for semi-open impellers                |
|---------------------|--------------------------------|--|
| Size 6 thru size 12 | 3~4 mm<br>(0.13~0.15 in.)      | 0.25 mm to 0.38 mm<br>(0.010 in. to 0.015 in.) |
| Size 14 and above.  | 6~7 mm<br>(0.25~0.27 in.)      | 0.63 mm to 0.76 mm<br>(0.025 in. to 0.030 in.) |

**Note:** Shafts elongate due to the hydraulic thrust of the pump and the impellers must be compensated for this elongation. Shaft elongation varies for each model depending upon the size, shaft length, shaft diameter, impeller weight, number of stages. Please see the documentation supplied along with the pump for exact impeller setting value matched for the specific pump that you have purchased

**5.3.1.2 Head shaft nut adjustment**

| Head Shaft size mm (in.)                         | Threads per every 25 mm (1 in.) length of the shaft | Lateral adjustment mm (in.)                               |                  |
|--|---|---|------------------|
|  |   | One complete turn of nut will result in shaft movement of | Each face of nut |
| 25 (1.0)   | 14  | 1.81<br>(0.070)   | 0.30<br>(0.012)  |
| 32 (1.25)<br>38 (1.50)<br>43 (1.69)              | 12  | 2.11<br>(0.080)   | 0.35<br>(0.014)  |
| 43 (1.69)<br>50 (1.94)<br>55 (2.19)<br>62 (2.44) | 10  | 2.54<br>(0.100)   | 0.40<br>(0.016)  |
| 68 (2.69)<br>75 (2.94)                           | 8   | 3.17<br>(0.120)   | 0.53<br>(0.020)  |

**5.3.2 Impeller adjustment for a solid shaft driver**

Impeller adjustment when using solid shaft drivers is accomplished in the adjustable flanged coupling located below the driver.

**5.3.2.1 Adjusting adjustable flanged coupling**

- a) Assemble coupling on pump shaft and driver shaft (if not installed earlier).
- b) Check motor direction of rotation.
- c) Check and write down Flowserve recommended impeller setting for final adjustment.
- d) Pump to motor alignment and final coupling
  - Mount two magnetic indicator bases on the discharge head at 90 degrees to each other
  - Set the indicator tips on the shaft just above the seal and at 90 degrees to each other. (Usually parallel and perpendicular to the discharge nozzle) push the shaft (parallel to discharge) back and forth (without bending shaft)
  - Note and record the minimum and maximum indicator readings. Do the same procedure at 90 degrees to the discharge

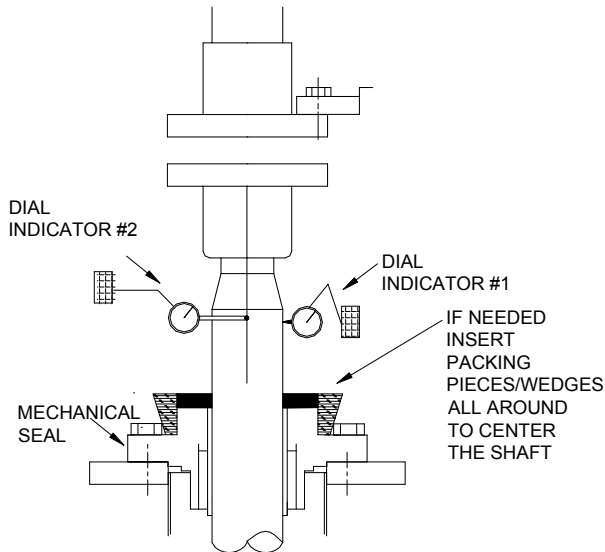

- Set the shaft in the center of the maximum and minimum indicator readings both directions. If the shaft will not stay in this position, use small wooden wedges between the shaft and seal bolts to hold the shaft. The indicators can now be removed
- **Alternate method for pump with packing:** Using an inside micrometer, measure the space between the shaft and the packing box bore. Do this both parallel and perpendicular to the discharge nozzle

Using the wedges center the shaft so the measurements taken at 180 degrees to each other are within 0.10 mm (0.004 in.) of being equal **(For pumps using jackscrews for motor go to step f).**

- e) Mount the magnetic base on the drive half coupling (a band clamp may be necessary to hold base due to limited space). Position the tip of the indicator on the pump shaft just above the seal. Slowly rotate the driver shaft.

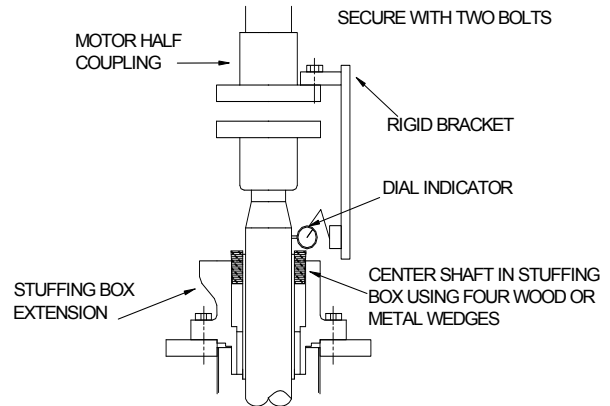

Note and record the T.I.R. reading. If this reading is more than 0.25 mm (0.010 in.) for WA and WSA couplings or 0.15 mm (0.006 in.) for PA and PSA couplings, unbolt the drive and reposition the driver in the direction required to reduce the T.I.R. to within the allowable limits.

**Note:** If a register fit is used for alignment, driver will be able to be moved only a few thousandths of an inch. If enough movement is not obtainable then the male register can be filed to obtain acceptable T.I.R. readings (Go to step 9).

- f) On pumps using jackscrews for motor alignment, mount the dial indicator base on the O.D. of the motor half coupling. Set the indicator on the shaft, position the dial to zero being careful that the indicator is in direct line with one of the jackscrews. Record this reading then rotate the motor shaft and indicator 180 degrees.

Record this reading being careful to note plus or minus values. Take the difference of the two readings and using the jackscrews move the motor one half of the difference. Repeat this step until the T.I.R. reading is a maximum of 0.05 mm (0.002 in.).

Then repeat this step for the set of jackscrews located 90 degrees to the first set. Once all readings are within 0.05 mm (0.002 in.) tighten motor bolts and check for any movement in readings.

- g) Set the impeller setting gap between the adjusting nut and the driver portion of the coupling. See impeller setting data supplied along with the pump. If this information is not found, contact Flowserve. Align the match marks on the pump half coupling with the driver half coupling. On pumps with enclosed impellers the match marks can be lined up by increasing the impeller gap until the marks are in line with the driver half coupling marks.

**Note:**

On pumps with semi-open impellers, the match marks probably will not be in line when the gap is set. **DO NOT** try to align the marking on the nut with the other markings.

For pumps with enclosed impellers go to step (h).

- h) Using 2 bolts of the coupling, at 180 degrees to each other, slowly raise pump half coupling until impellers are just lifted off the seat (This can be gauged by trying to turn shaft by hand. At the point the impellers are lifted the pump will turn). Be sure to lift both sides evenly.
- i) Measure the resultant gap between the motor half coupling and the adjusting nut.
- j) Find the difference between the original gap and the new gap. Add this difference to the original gap and reset the adjusting nut.
- k) Bolt the coupling together and tighten bolts by tightening opposite sides.
- l) Remove wooden wedges, if used. Mount magnetic base on pump and set the tip of indicator on the shaft just above the seal. Slowly rotate the shaft and note the T.I.R. reading.

Unless otherwise specified, the allowable T.I.R. readings are:

- WA and WSA couplings 0.10 mm (0.004 in.)
- PA and PSA couplings 0.05 mm (0.002 in.)

If the reading is larger than the allowable values specified above, unbolt the pump and rotate the driver portion of the coupling to different hole and repeat steps (h) and (i) until acceptable readings are obtained.

- m) If a mechanical seal is used, adjust the mechanical seal at this time.

### 5.4 Direction of Rotation



Ensure the pump is given the same rotation as specified or as marked on the pump/driver. Please contact Flowserve representative, if you have any questions before the startup.

To avoid dry running the pump must either be filled with liquid or have the flexible coupling disconnected before the driver is switched on.



If maintenance work has been carried out to the site's electricity supply, the direction of rotation should be re-checked as above in case the supply phasing has been altered.

### 5.5 Guarding



Guarding is supplied fitted to the pump set. Fasteners for guards must remain captive in the guard to comply with the Machinery Directive 2006/42/EC. When releasing guards, the fasteners must be unscrewed in an appropriate way to ensure that the fasteners remain captive. Whenever guarding is removed or disturbed ensure that all the protective guards are securely refitted prior to start-up

### 5.6 Priming and Auxiliary Supplies



Ensure electrical, hydraulic, pneumatic, sealant and lubrication systems (as applicable) are connected and operational.



Ensure the inlet pipe and pump casing are completely full of liquid before starting continuous duty operation.

### 5.6.1 Pump submergence

Minimum submergence is required to prevent vortex formation.

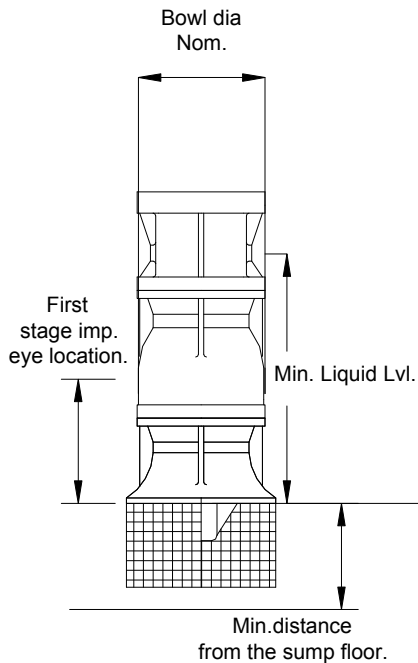

The submergence varies in general from 2 to 3 times the nominal bowl diameter and is always specific to each pump model. The submergence needed for adequate NPSH to the first stage impeller may be different from the general rule mentioned earlier. Location of the first stage impeller eye to be taken into account for minimum priming submergence. It is also equally important to take note of the minimum distance to be maintained to the suction bell from the sump floor (with or without strainer). Therefore, refer to the Flowserve supplied general assembly drawing on minimum submergence or contact Flowserve before the pump is started.

## 5.7 Starting the Pump

### 5.7.1 Pre-starting checks

Before starting the pump the following checks should be made.

- a) Rotate the pump shaft by hand to make sure the pump rotates freely and the impellers are correctly positioned.
- b) Ensure that the electric motor has been properly lubricated in accordance with the instructions furnished with the driver.
- c) Ensure the electric motor has been checked for proper rotation. The pump must be disconnected from the driver at the coupling before checking.

The electric motor must rotate counter-clockwise when looking down on the top of the driver.

- d) Check all connections to the driver and control. Do not overfill the grease cavity. Over greasing can lead to overheating and premature failure of the thrust bearing.
- e) Check that all piping connections are tight.
- f) Check all foundation bolts for tightness.
- g) Check all bolting connections for tightness (coupling bolts, mechanical seal gland bolts, driver bolts etc).
- h) Make sure the mechanical seal is properly adjusted and locked into place. Ensure that all seal spacers are in the running position prior to operation.
- i) All guards must be secured in position prior to pump startup to prevent possible contact with rotating parts.

To ensure proper alignment three items are very important during installation and they are:

- All machined mating surfaces (such as the mating faces of the pump and motor) must be clean and free from burrs and nicks. These surfaces should be cleaned thoroughly with a scraper, wire brush and emery cloth if necessary and all nicks or burrs removed with a fine file
- Exterior strain must not be transmitted to the pump. The most common cause of trouble in this respect is forcing the piping to mate with the pump. It is recommended that flexible connectors be installed in the piping adjacent to the pump.
- All threads should be checked for damage and repaired if necessary. If filing is necessary, remove the part from the pump if possible, or arrange to catch all the filings so they do not fall onto other parts of the pump. Clean all threads with a wire brush and approved cleaning solvent, ends of shafts must be cleaned and any burrs removed since alignment depends on the shaft ends butting squarely. Lubricate all threaded connections with a suitable approved thread lubricant (an approved anti-galling compound should be used on stainless mating threads)
- j) On pumps equipped with mechanical seals, clean fluid should be put into the seal chamber. With pumps under suction pressure, this can be accomplished by bleeding all air and vapor out of the seal chamber and allowing the fluid to enter. With pumps not under suction pressure, the seal chamber should be flushed liberally with clean fluid to provide initial lubrication. Make sure the mechanical seal is properly adjusted and locked into place. Insure that all seal spacers are removed prior to operation.



5.7.1.1 **Typical safety guards**

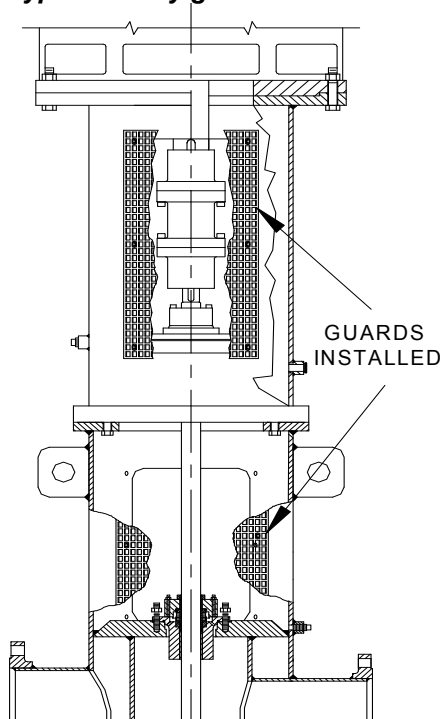

After initial startup, pre-lubrication of the mechanical seal will usually not be required as enough liquid will remain in the seal chamber for subsequent startup lubrication.

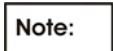

A screen guard is furnished with all pumps having a two-piece headshaft or an adjustable flanged coupling. This screen must be secured in place prior to pump startup to prevent possible contact with rotating parts. Typical arrangement is shown in section 5.7.1.1.

5.7.2 **Stuffing box adjustment**

On the initial starting it is very important that the packing not be tightened excessively. New packing must be run in properly to prevent damage to the shaft and shortening of the packing life.

The stuffing box must be allowed to leak for proper operation. The proper amount of leakage can be determined by checking the temperature of the leakage, this should be cool or just lukewarm - NOT HOT - usually 40 to 60 drops per minute will be adequate.

When adjusting the packing gland, bring both nuts down evenly and in small steps until the leakage is reduced as required. The nuts should only be

tightened about one half turn at a time at 20 to 30 minute intervals to allow the packing to "run-in". Under proper operation, a packing set will last a long time. Occasionally a new ring of packing will need to be added to keep the box full.

After adding two or three rings of packing, or when proper adjustment cannot be achieved, the stuffing box should be cleaned completely of all old packing and re-packed.

5.7.3 **Open shaft lubrication before startup**

Open lineshaft bearings are lubricated by the pumped fluid on short-coupled units less than 15 m (50 ft) long and usually do not require pre- or post-lubrication. All open lineshaft pumps where the static water level is more than 15 m (50 ft) below the discharge head should be adequately pre-lubricated before startup. These units should have a non-reverse ratchet on the driver to prevent backspin when turning off pump. If there is no NRR, post-lubrication is also necessary.

5.7.4 **Enclosed shaft lubrication before start up**

Enclosed lineshaft bearings are lubricated by an extraneous liquid (usually oil or clean water

The oil reservoir must be kept filled with a good quality of light turbine oil (about 30 cSt (mm<sup>2</sup>/sec) at operating temperature) and adjusted to feed 3 drops/minute for every 30 m (100 ft) of column.

Injection systems are designed for each installation. Injection pressure and quantity of lubricating liquid will vary. Usually 0.45 to 0.90 m<sup>3</sup>/h (2 to 4 gpm) at 0.7 to 0.14 bar (10 to 20 psi) over maximum pump discharge pressure of clean liquid is required.

For recommended oils for enclosed lineshaft bearing lubrication under normal operating conditions, please see tables 5.2.3.1 and 5.2.3.2. If none of the above oils are available, oil with the following specifications should be obtained. Turbine type oil with rust and oxidation inhibitors added, viscosity 30 cSt (mm<sup>2</sup>/sec) to 37 cSt (mm<sup>2</sup>/sec) at 40 °C (100 °F) with a minimum viscosity index of 90.



In the case of product-lubricated bearings, the source of product supply should be checked against the order. There may be requirements for an external clean supply, particular supply pressure or the commencement of lubrication supply before pump startup.

**5.7.5 Initial Starting**

**CAUTION** Ensure flushing and/or cooling/heating liquid supplies are turned ON before starting the pump.

- a) If the discharge line has a valve in it, partially open the discharge valve closest to the pump. The discharge valve is intended to add sufficient system resistance to the pump. Failure to maintain pump flow rates within the limits of the pump and motor could result in severe damage.
- b) OPEN all inlet valves.
- c) Prime the pump & check lubrication system in operation (check the liquid level).
- d) Ensure all vent connections are closed before starting.
- e) Check the motor connections.
- f) Start pre-lubrication liquid flow on pump if required.
- g) Start the pump and observe the operation. If there is any difficulty, excess noise or vibration, stop the pump immediately and refer to the Trouble Shooting Chart (section 7.0) to determine the probable cause.

**CAUTION** Do not run the pump with the outlet valve closed for a period longer than 30 seconds.

- h) Open vent connections and ensure that the unit is vented of all trapped vapor before closing the vents.

**CAUTION** Observe extreme caution when venting and or draining hazardous liquids. Wear protective clothing in the presence of caustic, corrosive, volatile, flammable or hot liquids. Do not breathe toxic vapors. Do not allow sparking, flames or hot surfaces in the vicinity of the equipment.

- i) Open the discharge valve as desired to operate the unit at its design conditions.
- j) Check complete pump and driver for leaks, loose connections, or improper operation.

If possible, the pump should be left running for approximately one half hour on the initial startup, this will allow the bearings, packing or seals, and other parts to "run-in" and reduce the possibility of trouble on future starts.

**CAUTION** If abrasives or debris are present, upon startup, the pump should be allowed to run until the pumpage is clean. Stopping the pump when handling large amounts of abrasives (as is

sometimes present on initial starting) may lock the pump and cause more damage than the pump is allowed to continue operation.

Every effort should be made to keep abrasives out of lines, sump, etc. so that abrasives will not enter the pump.

**CAUTION** In the case of product lubricated bearings the source of product supply should be checked against the order. There may be requirements for an external clean supply, particular supply pressure or the commencement of lubrication supply before pump start-up.

**5.7.6 Frequency of lubrication**

The characteristics of the installation and severity of service will determine the frequency of lubrication. Lubricant and pump/motor bearing temperature analysis is useful in optimizing lubricant change intervals.

The motor bearing temperature limitations should be considered for its lubrication requirements. Refer to the driver manufacturer's user instructions supplied with the pump. If documents are not found contact Flowserve.

**CAUTION** Never mix greases containing different bases, thickeners or additives.

**5.7.7 Normal vibration levels, alarm and trip**

Pumps generally fall under classification of rigid support machines within the International Rotating Machinery standard and maximum vibration levels are based on those standards

**CAUTION** Alarm and trip values for installed pumps should be based on the actual measurements (N) taken on the pump in a fully commissioned (new) condition. Measuring vibration at regular intervals and recording will help to track any deterioration in pump or operating conditions. Measurements shall be taken at the pump/motor interface.

**5.7.7.1 Typical allowable field vibration values for vertical turbines- sump or wet pit types**

| Motor rating kW (hp)  | Vibration velocity-unfiltered | Vibration mm/sec (in./sec) rms |
|-----------------------|-------------------------------|--------------------------------|
| 0.75-to 7.5 (1-10)    | N                             | 6.1 (0.24)                     |
| 7.5 to 75 (10 -100)   | N                             | 6.1 (0.24)                     |
| 75 to 750 (100 -1000) | N                             | 6.1 (0.24)-7.1 (0.28)          |

N = Normal; Alarm = N X1.25; TRIP = N X 2.0.

**5.7.7.2 Typical allowable field vibration values for vertical turbines with suction barrel**

| Motor rating kW (hp)    | Vibration velocity-unfiltered | Vibration mm/sec (in./sec) rms |
|-------------------------|-------------------------------|--------------------------------|
| 0.75-to 7.5 (1-10)      | N                             | 5.1 (0.20)                     |
| 7.5 to 75 (10-100)      | N                             | 5.1 (0.20)                     |
| 75 to 750 (100-1000)    | N                             | 5.1 (0.20)-6.1(0.24)           |
| 750 to 2250 (1000-3000) | N                             | 6.1 (0.24)-7.1(0.28)           |

N = Normal; Alarm = N X 1.25; TRIP = N X 2.0.

**5.7.8 Motor start/stop frequency**

Even though motors are normally suitable for at least two consecutive starts, it is recommended to restart only after coasting to rest between starts (minimum of 15 minutes gap), with the motor initially at ambient temperature. If more frequent starting is necessary, refer to driver manufacturer’s instructions or contact Flowserve with details.

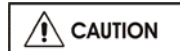

The number of motor start and stops in any given time affects motor life.



If the motor is expected to experience multi starts in any given time, please refer to the driver’s user instructions before the pump is put into operation.

**5.8 Operating the Pump**

**5.8.1 Venting the pump**



Make sure that the pump is vented to enable all trapped air to escape, taking due care with the hazardous or hot liquids. Under normal conditions after the pump is fully vented and primed, it should be unnecessary to re-vent the pump.

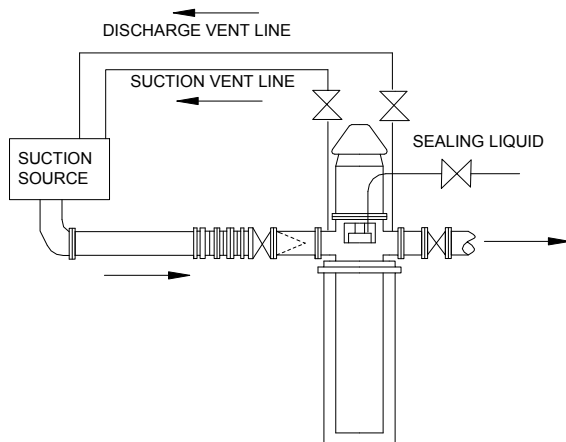

**5.8.2 Pumps fitted with packed glands**

If the pump has a packed gland, there must be some leakage from the gland. Gland nuts should initially be finger-tight only. Leakage should take place soon after the stuffing box is pressurized.



The gland must be adjusted evenly to give visible leakage and concentric alignment of the gland ring to avoid excess temperature. If no leakage takes place, the packing will begin to overheat.

If overheating takes place, the pump should be stopped and allowed to cool before being re-started. When the pump is re-started, check to ensure leakage is taking place at the packing gland.

If hot liquids are being pumped it may be necessary to loosen the gland nuts to achieve leakage.

The pump should be run for 30 minutes with steady leakage and the gland nuts tightened by 10 degrees at a time until leakage is reduced to an acceptable level, normally a minimum of 40-60 drops per minute is required.



Care must be taken when adjusting the gland on an operating pump. Safety gloves are essential. Loose clothing must not be worn to avoid being caught by the pump shaft. Shaft guards must be replaced after the gland adjustment is complete.



Never run gland packing dry, even for a short time.

**5.8.3 Pumps fitted with mechanical seal**

Mechanical seals require no adjustment. Any slight initial leakage will stop when the seal is run in.

Before pumping dirty liquids, it is advisable, if possible, to run in the pump mechanical seal using clean liquid to safeguard the seal face.



External flush or quench should be started before the pump is run and allowed to flow for a period after the pump has stopped.



Never run a mechanical seal dry, even for a short time.

**5.8.4 Pump and motor bearing temperature**



If the pumps are working in a potentially explosive atmosphere, temperature or vibration monitoring at the bearings is recommended.

If pump bearing temperatures (such as thrust bearings) are to be monitored it is essential that a benchmark temperature is recorded at the commissioning stage and after the bearing temperature has stabilized.

- Record the bearing temperature (t) and the ambient temperature (ta)
- Estimate the likely maximum ambient temperature (tb)
- Set the alarm at  $(t+tb-ta+5) ^\circ\text{C}$  [ $(t+tb-ta+10) ^\circ\text{F}$ ] and the trip at  $100 ^\circ\text{C}$  ( $212 ^\circ\text{F}$ ) for oil lubrication and  $105 ^\circ\text{C}$  ( $220 ^\circ\text{F}$ ) for grease lubrication

It is important, particularly with grease lubrication, to keep a close watch on the bearing temperatures. After startup the temperature rise should be gradual, reaching a maximum after approximately 1.5 to 2 hours. This temperature rise should then remain constant or marginally reduce with time.

**5.8.5 Multiple Can Pump Operation**

Additional procedures may be required in multiple can pump systems when one or more pump remains idle. Contact Flowserve for details.

**5.9 Stopping and Shutdown**

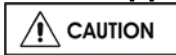

- a) Close the outlet valve, but ensure that the pump runs in this condition for no more than a few seconds.
- b) Stop the pump.
- c) Switch off flushing and/or cooling/heating liquid supplies at a time appropriate to the process.

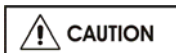

For prolonged shutdowns and especially when ambient temperatures are likely to drop below freezing point, the pump and any cooling and flushing arrangements must be drained or otherwise protected.

**5.10 Hydraulic, mechanical and electrical duty**

This product has been supplied to meet the performance specifications of your purchase order, however it is understood that during the life of the product these may change. The following notes may help the user decide how to evaluate the implications

of any change. If in doubt contact your nearest Flowserve office.

**5.10.1 Specific gravity (SG)**

Pump capacity and total head in metres (feet) do not change with SG, however pressure displayed on a pressure gauge is directly proportional to SG. Power absorbed is also directly proportional to SG. It is therefore important to check that any change in SG will not overload the pump driver or over-pressurize the pump.

**5.10.2 Viscosity**

For a given flow rate the total head reduces with increased viscosity and increases with reduced viscosity. Also for a given flow rate the power absorbed increases with increased viscosity, and reduces with reduced viscosity. It is important that checks are made with your nearest Flowserve office if changes in viscosity are planned.

**5.10.3 Pump speed**

Changing pump speed effects flow, total head, power absorbed, NPSH<sub>R</sub>, noise and vibration. Flow varies in direct proportion to pump speed, head varies as speed ratio squared and power varies as speed ratio cubed. The new duty, however, will also be dependent on the system curve. If increasing the speed, it is important therefore to ensure the maximum pump working pressure is not exceeded, the driver is not overloaded, NPSH<sub>A</sub> > NPSH<sub>R</sub>, and that noise and vibration are within local requirements and regulations.

**5.10.4 Net positive suction head (NPSH<sub>A</sub>)**

NPSH available (NPSH<sub>A</sub>) is a measure of the head available in the pumped liquid, above its vapour pressure, at the pump suction branch.

NPSH required (NPSH<sub>R</sub>) is a measure of the head required in the pumped liquid, above its vapour pressure, to prevent the pump from cavitating. It is important that NPSH<sub>A</sub> > NPSH<sub>R</sub>. The margin between NPSH<sub>A</sub> > NPSH<sub>R</sub> should be as large as possible. If any change in NPSH<sub>A</sub> is proposed, ensure these margins are not significantly eroded. Refer to the pump performance curve to determine exact requirements particularly if flow has changed.

If in doubt please consult your nearest Flowserve office for advice and details of the minimum allowable margin for your application.

**5.10.5 Pumped flow**

Flow must not fall outside the minimum and maximum continuous safe flow shown on the pump performance curve and or data sheet.



## 6 MAINTENANCE

### 6.1 General



It is the plant operator's responsibility to ensure that all maintenance, inspection and assembly work is carried out by authorized and qualified personnel who have adequately familiarized themselves with the subject matter by studying this manual in detail. (See also section 1.6.)

Any work on the machine must be performed when it is at a standstill. It is imperative that the procedure for shutting down the machine is followed, as described in section 5.9.

Guard fasteners must remain captive during dismantling of guards as described in section 5.5

On completion of work all guards and safety devices must be re-installed and made operative again.

Before restarting the machine, the relevant instructions listed in section 5, *Commissioning, start up, operation and shut down* must be observed.

***Oil and grease leaks may make the ground slippery. Machine maintenance must always begin and finish by cleaning the ground and the exterior of the machine.***

If platforms, stairs and guard rails are required for maintenance, they must be placed for easy access to areas where maintenance and inspection are to be carried out. The positioning of these accessories must not limit access or hinder the lifting of the part to be serviced.

When air or compressed inert gas is used in the maintenance process, the operator and anyone in the vicinity must be careful and have the appropriate protection.

Do not spray air or compressed inert gas on skin.

Do not direct an air or gas jet towards other people.

Never use air or compressed inert gas to clean clothes.

Before working on the pump, take measures to prevent an uncontrolled start. Put a warning board on the starting device with the words: ***"Machine under repair: do not start"***.

With electric drive equipment, lock the main switch open and withdraw any fuses. Put a warning board on the fuse box or main switch with the words: ***"Machine under repair: do not connect"***.

Never clean equipment with inflammable solvents or carbon tetrachloride. Protect yourself against toxic fumes when using cleaning agents.

### 6.2 Maintenance Schedule



It is recommended that a maintenance plan and schedule is adopted, in line with these User Instructions, to include the following:

- a) *Any auxiliary systems installed must be monitored, if necessary, to ensure they function correctly.*
- b) Gland packings must be adjusted correctly to give visible leakage and concentric alignment of the gland follower to prevent excessive temperature of the packing or follower.
- c) Check for any leaks from gaskets and seals. The correct functioning of the shaft seal must be checked regularly.
- d) Check bearing lubricant level, and if the hours run show a lubricant change is required.
- e) Check that the duty condition is in the safe operating range for the pump.
- f) Check vibration, noise level and surface temperature at the bearings to confirm satisfactory operation.
- g) Check dirt and dust is removed from areas around close clearances, bearing housings and motors.
- h) Check coupling alignment and re-align if necessary.

Our specialist service personnel can help with preventative maintenance records and provide condition monitoring for temperature and vibration to identify the onset of potential problems.

If any problems are found the following sequence of actions should take place:

- a) Refer to section 8, *Faults; causes and remedies*, for fault diagnosis.
  - b) Ensure equipment complies with the recommendations in this manual.
- Contact Flowserve if the problem persists.

**6.2.1 Routine inspection (daily/weekly)**



The following checks should be made and the appropriate action taken to remedy any deviations.

- a) Check operating behavior; ensure noise, vibration and bearing temperatures are normal.
- b) Check that there are no abnormal fluid or lubricant leaks (static and dynamic seals) and that any sealant systems (if fitted) are full and operating normally.
- c) Check that shaft seal leaks are within acceptable limits.
- d) Check the level and condition of lubrication oil. On grease lubricated pumps, check running hours since last recharge of grease or complete grease change.
- e) Check any auxiliary supplies eg. heating/cooling (if fitted) are operating correctly.
- f) Refer to the manuals of any associated equipment if routine checks needed.

**6.2.2 Periodic inspection (every 6 Months)**



- a) Check foundation bolts for security of attachment and corrosion.
- b) Check pump operation hours to determine if bearing lubricant shall be changed.
- c) The coupling should be checked for correct alignment and worn driving elements.



Refer to the manuals of any associated equipment for periodic checks needed.

**6.2.3 Re-lubrication**

**6.2.3.1 Pump lubrication**

In general, VTPs that are product lubricated will not require further periodic lubrication. Stuffing box and mechanical seal needs flow of flush. Enclosed line shaft pumps have to be provided with the required oil quantity for an oil lubed system and the injection lube flow at the required pressure for injection lubed systems.

**6.2.3.2 Driver lubrication**



Refer to driver manufacturer's User Instructions supplied with the pump.

**6.2.4 Impeller re-adjustment**

Ordinarily, impellers will not require re-adjustment if properly set at initial installation.



All adjustments of the impellers will change the seal setting, therefore, the seal must be loosened from the shaft until the adjustment is completed and then reset.

**6.2.5 Maintenance of the stuffing box**

**6.2.5.1 General**

Maintenance of the stuffing box will consist of greasing the box when required, tightening the packing gland occasionally as the leakage becomes excessive, and installing new packing rings or sets as required.

**6.2.5.2 Greasing the stuffing box**

Under ordinary operation, once-a-month greasing of the stuffing box will be adequate. A high quality industrial grade # 2 grease is recommended.

**6.2.5.3 Replacing packing**

Remove gland and all old packing. If the box contains a lantern ring, remove this and all packing below it using two long threaded machine screws.

Inspect shaft or sleeve for score marks or rough spots. Be sure by-pass holes (if supplied) are not plugged. Repair or replace badly worn shaft or sleeve.

If wear is minor dress down until smooth and concentric. Clean box bore.

Oil inside and outside of replacement rings lightly and install in box, staggering joints 90 degrees. Be sure to replace lantern ring in proper position when used.

Replace gland and tighten nuts finger tight. The packing gland must never be tightened to the point where leakage from the packing is stopped.

A small amount of leakage is required for packing lubrication.

Packing ring sizes vary with the shaft diameter. Packing ring size information are as follows.



**PACKING RING SIZES**

| Packing Dimensions |                   |                             |
|--------------------|-------------------|-----------------------------|
| Shaft size         | Packing ring size | Outside diameter of packing |
| mm (in.)           | mm (in.)          | mm (in.)                    |
| 25 (1.00)          | 9.65 (0.38)       | 44.4 (1.75)                 |
| 32 (1.25)          | 9.65 (0.38)       | 50.8 (2.00)                 |
| 38 (1.50)          | 11.17 (0.44)      | 60.4 (2.38)                 |
| 43 (1.69)          | 12.70 (0.50)      | 68.3 (2.68)                 |
| 49 (1.93)          | 12.70 (0.50)      | 74.6 (2.93)                 |
| 56 (2.20)          | 12.70 (0.50)      | 81.0 (3.19)                 |
| 62 (2.44)          | 12.70 (0.50)      | 87.3 (3.43)                 |
| 68 (2.68)          | 12.70 (0.50)      | 93.7 (3.69)                 |
| 75 (2.95)          | 12.70 (0.50)      | 100.0 (3.93)                |
| 82 (3.22)          | 12.70 (0.50)      | 107.9 (4.24)                |
| 89 (3.50)          | 15.74 (0.62)      | 120.6 (4.74)                |
| 95 (3.75)          | 15.74 (0.62)      | 127.0 (5.00)                |
| 102 (4.00)         | 15.74 (0.62)      | 133.3 (5.24)                |
| 114 (4.50)         | 15.74 (0.62)      | 146.0 (5.74)                |

**6.2.5.4 Startup with new packing**

Check to see that the by-pass line (if used) is connected and the packing gland is loose. Start pump and allow it to run for 20 to 30 minutes. Do not tighten the gland during this "run-in" period even if leakage is excessive. Should the new packing cause excessive heating during "run-in", flush the shaft and packing box area with cold water or shut the pump down and allow to cool.

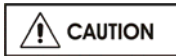

For all repair instructions please call Flowserve representative or customer service with the order no. and unit details for specific repair instruction literature.

All repair work to be carried out by trained and authorized personnel only. Flowserve's written permission may be required for any disassembly/repair of the pump that is still under warranty.

**6.3 Spare Parts**

**6.3.1 Ordering of spares**

Flowserve keep records of all pumps that have been supplied. When ordering spare parts we need the following information:

1. pump type and pump size
2. serial number of the pump
3. number of the required spare parts
4. reference number and name of the part as listed in the part list or in the sectional drawing

The pump size and serial number are as shown on the pump nameplate.

**6.3.2 How to select recommended spares**

Generally a list of spare parts supplied along with the pump that shows the parts that are included in each of the following two classes of recommended spares. If you do not find such documentation please contact Flowserve for the list.

**6.3.2.1 Class I minimum**

Suggested for Domestic Service when pump is handling clean non-corrosive liquids and where interruptions in service are not important.

**6.3.2.2 Class II average**

Suggested for Domestic Service when pump is handling abrasive or corrosive liquids and where some interruptions in continuity of service are not objectionable.

Please contact Flowserve Sales Representative in your area to review the spares best suited to meet your requirements.

**6.3.3 Storage of spare parts**

Spares should be stored in a clean dry area away from vibration. Inspection and re-treatment of metallic surfaces (if necessary) with preservative is recommended at 6-month intervals.

**6.4 Recommended Spares and Consumables**

A list of spares and consumables are generally included along with this User Instructions and other documents that you have received along with the pump and is made specifically to your order. In the event that the list is not found, please contact Flowserve with pump type and order no.

**6.5 Tools Required**

**Standard tools needed to maintain this pump are follows.**

- Open ended spanners / wrenches (standard size range)
- Socket spanners / wrenches (standard size range)
- Allen keys/wrenches
- Standard range of screw drivers
- Soft mallet

For drive collet pumps:

- Collet driver
- Sand collar (if not provided on the unit)
- Tie down bolt

**Note:** Other tools may be required depending on the accessories/ special parts used per contract. Flowserve in general is not obligated to ship the tools with any pump shipped.

### 6.6 Fastener Torques

**Note:** Torque values shown are for standard fasteners lubricated with high stress lubricant such as graphite-oil, moly-disulphite, white lead, etc.

#### 6.6.1 Fastener torques for bowl assembly

| BOLT TORQUE VALUES FOR CLASS 2 LUBRICATED TREADS |                         |   |                            |                   |                      |                           |                     |
|--|-------------------------|---|----------------------------|-------------------|----------------------|---------------------------|---------------------|
| Thread Data                                      |                         | Material group                                    |                            |                   |                      |                           |                     |
|  |                         | A   | B                          | C                 | D                    | E                         | F                   |
|  |                         | 316 SS  | ASTM B164<br>UNS<br>NO4400 | Hastalloy<br>C276 | ASTM A449<br>GRADE 5 | ASTM<br>A193<br>Grade B7M | SAE J429<br>Grade 8 |
|  |                         | Approximate Yield stress –N/mm <sup>2</sup> (psi) |                            |                   |                      |                           |                     |
| Nominal Diameter                                 | Threads per 25 mm (in.) | 207<br>(30000)                                    | 276<br>(40000)             | 345<br>(50000)    | 441<br>(60000)       | 552<br>(80000)            | 690<br>(100000)     |
| mm (in.)   |                         | Torque Nm (lbf ft)                                |                            |                   |                      |                           |                     |
| 6 (0.25)   | 20                      | 4(3)  | 5(4)                       | 5(4)              | 7(5)                 | 9(7)                      | 12(9)               |
| 8 (0.31)   | 18                      | 7(5)  | 8(6)                       | 11(8)             | 14(10)               | 17(13)                    | 21(16)              |
| 10 (0.37)  | 16                      | 9(7)  | 14(10)                     | 16(12)            | 20(15)               | 27(20)                    | 34(25)              |
| 11 (0.43)  | 14                      | 16(12)  | 20(15)                     | 25(19)            | 31(23)               | 42(31)                    | 53(39)              |
| 12 (0.5)   | 13                      | 23(17)  | 31(23)                     | 39(29)            | 47(35)               | 62(46)                    | 78(58)              |
| 15 (0.56)  | 12                      | 27(20)  | 45(33)                     | 75(41)            | 66(49)               | 89(66)                    | 111(82)             |
| 16 (0.62)  | 11                      | 41(30)  | 60(44)                     | 54(73)            | 88(65)               | 118(87)                   | 149(110)            |
| 19 (0.74)  | 10                      | 81(60)  | 101(75)                    | 127(94)           | 149(110)             | 203(150)                  | 257(190)            |
| 22 (0.87)  | 9                       | 122(90)   | 163(120)                   | 203(150)          | 258(190)             | 312(250)                  | 420(310)            |
| 25 (1.00)  | 8                       | 190(140)  | 244(180)                   | 312(230)          | 366(270)             | 488(360)                  | 610(450)            |
| 29 (1.13)  | 7                       | 271(200)  | 352(260)                   | 448(330)          | 529(390)             | 705(520)                  | 882(650)            |
| 29 (1.13)  | 7                       | 271(200)  | 366(270)                   | 461(340)          | 556(410)             | 732(540)                  | 923(680)            |
| 32(1.25)   | 7                       | 366(270)  | 488(360)                   | 610(450)          | 746(550)             | 990(730)                  | 1235(910)           |
| 32(1.25)   | 8                       | 379(280)  | 502(370)                   | 637(470)          | 760(560)             | 1017(750)                 | 1275(940)           |
| 35(1.38)   | 6                       | 434(320)  | 570(420)                   | 719(530)          | 855(630)             | 1140(840)                 | 1425(1050)          |
| 35(1.38)   | 8                       | 461(340)  | 610(450)                   | 760(560)          | 922(680)             | 1221(900)                 | 1533(1130)          |
| 38(1.50)   | 6                       | 556(410)  | 746(550)                   | 936(690)          | 1126(830)            | 1506(1110)                | 1872(1380)          |
| 38(1.50)   | 8                       | 597(440)  | 800(590)                   | 990(730)          | 1194(880)            | 1587(1170)                | 1995(1470)          |
| 41(1.63)   | 5.5                     | 719(530)  | 963(710)                   | 1207(890)         | 1438(1060)           | 1927(1420)                | 2402(1770)          |
| 41(1.63)   | 8                       | 773(570)  | 1031(760)                  | 1302(960)         | 1560(1150)           | 2076(1530)                | 2592(1910)          |
| 44(1.75)   | 5                       | 882(650)  | 1180(870)                  | 1479(1090)        | 1778(1310)           | 2375(1750)                | 2958(2180)          |
| 44(1.75)   | 8                       | 971(720)  | 1302(960)                  | 1628(1200)        | 1940(1430)           | 2592(1910)                |                     |
| 50(2.00)   | 4.5                     | 1356(1000)  | 1778(1310)                 | 2225(1640)        | 2673(1970)           |                           |                     |
| 50(2.00)   | 8                       | 1478(1090)  | 1968(1450)                 | 2470(1820)        | 2958(2180)           |                           |                     |
| 57(2.25)   | 8                       | 2143(1580)  | 2850(2100)                 |                   |                      |                           |                     |
| 63(2.50)   | 8                       | 2970(2190)  |                            |                   |                      |                           |                     |

### 6.6.2 Torques for couplings screws

| Coupling size # | Flange diameter mm (in.)        | Nm (lbf-ft)  |
|-----------------|---------------------------------|--------------|
| 1 & 2           | 111 or 137<br>(4.4 or 5.4)      | 122<br>(90)  |
| 3-5             | 156, 187 213<br>(6.0, 7.4, 8.4) | 237<br>(175) |
| 6               | 250<br>(10.0)                   | 424<br>(313) |

Torque values are for standard fasteners lubricated with a high stress lubricant (such as, graphite and oil, moly-disulphite, white lead etc.). For stainless steel bolts, multiply listed torques by 0.80.

### 6.7 Setting Impeller Clearance

Please see section 5.3 for specific instructions on impeller adjustment.

### 6.8 Disassembly



Refer to section 1.6, *Safety*, before dismantling the pump.



Before dismantling the pump for overhaul, ensure genuine Flowserve replacement parts are available. Refer to sectional drawings for part numbers and identification.



Please take precaution during disassembly that there is no risk of explosion due to the nature of the materials/ tools/ equipment/ method used. Wherever chemical and hazardous materials are involved, proper safety rules have to be followed to prevent any dangers to human lives or livestock. Contact Flowserve for guidance, or local regulatory agency for specific safety information.

#### 6.8.1 Pump disassembly instructions

See section 8 for sectional drawings.

- Disconnect all cables/wires and cooling water pipe connections to the driver (if provided).
- Carefully remove the flush or lubricant connections and remove any associated piping that would interfere with the dismantling.
- Make sure that all the valves are shut completely to avoid any leaks or spills.
- Disconnect the coupling halves [471] (the driver & pump).
- Disconnect the suction (if used) and discharge pipe connections to the discharge head.
- Rig the motor to a suitable hoist and keep the lifting mechanism in ready state.
- Remove the motor to discharge head [304] bolting and remove the motor from the discharge

head and place it on a safe and appropriate location.

- If the pump is of shorter length (with or without can) rig the discharge head along with the entire pump assembly (see section 2.3 for lifting) using a suitable hoist (check the building height clearance before the lifting is attempted)
- Use eye bolts and hooks as necessary and get the lifting mechanism in ready state.
- Lifting of short set pumps
  - Remove the fasteners at the discharge head/foundation/soleplate
  - Lift the entire pump assembly by clamping at the discharge head [304] (See section 2.3)
- Lifting of deep set pumps
  - Remove the fasteners at the foundation plate or soleplate
  - Remove stuffing box/Mechanical seal [349] completely. Protect the shaft against damage while lifting the discharge head [304]
  - Lift the pump just enough to access the first column pipe flange connection
  - Support the entire pump just below the first column pipe joint [101]
  - Disconnect the discharge head [304] and lift
  - Now lift the pump again by using column pipe flange and disconnect the first section of column piping
  - Remove the bearing retainers [307] and shaft couplings [70] and repeat the process until all column piping is disassembled
  - Last step is to lift and remove the bowl assembly

See section 2.3, 4.1.2 and 4.1.3 for related information.

### 6.9 Examination of Parts



Used parts must be inspected before assembly to ensure the pump will subsequently run properly. In particular, fault diagnosis is essential to enhance pump and plant reliability.

Before proceeding with assembly, thoroughly clean all bolts, nuts, threaded connections and mating faces. Clean up any burrs with a file or emery cloth.



Cleanliness and proper lubrication are required to guarantee ease of re-assembly and proper pump operation.

**6.9.1 Examination of shaft/s**

Check the shafts for straightness, pitting and wear. Remove all burrs or nicks. Shaft damage is usually best corrected by replacing the shaft.

The shaft must be straight to within 0.127 mm (0.005 in.) total indicator reading. The detail below shows the recommended method for checking shaft straightness. If the shaft is not straight, it must be straightened or replaced. If the deflection is gradual over a considerable length, the shaft can usually be straightened by supporting on two blocks straddling the crooked section and applying pressure to the high side to deflect the shaft in the opposite direction. If the shaft has a sharp crook (dog-leg), it is recommended that the shaft be replaced since the shaft will not always remain straight, even if satisfactorily straightened.

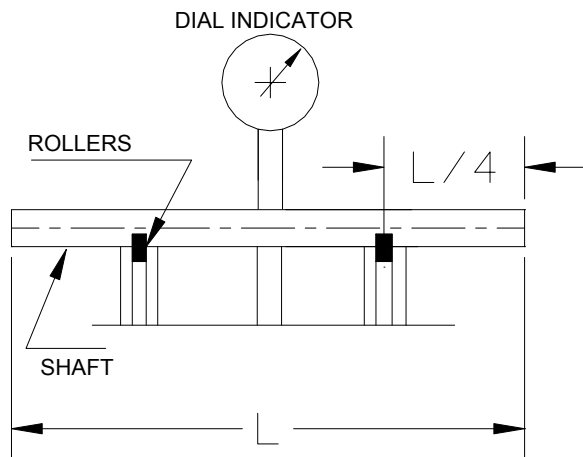

**CAUTION** Even if the shaft is new or has been previously straightened, it is recommended that the shaft be re-checked at this point to ensure damage has not occurred in transit or handling.

**6.9.2 Examination of bearings**

Check all bearings for total clearance over the shaft. It is recommended that all bearings indicating visual wear be replaced. In addition, any bearings whose running clearance exceeds "As New" tolerances by more than 50% should be replaced (see table 6.8.2.1).

**Note:** Rubber bearings should always be replaced when servicing a pump.

**6.9.2.1 Shaft/bearing clearance**

| Shaft Size<br>mm<br>(in.) | Shaft Diameter/Tolerance<br>Min Dia- Max Dia<br>mm<br>(in.) |                   | Bearing Clearance<br>(Max/Min)<br>mm<br>(in.) |
|---------------------------|---|-------------------|---|
|                           |   |                   |   |
| 25.40<br>(1.000)          | 25.35<br>(0.998)  | 25.40<br>(1.000)  | 0.28/0.13<br>(0.011/0.005)                    |
| 31.75<br>(1.250)          | 31.70<br>(1.248)  | 31.75<br>(1.250)  | 0.35/0.15<br>(0.012/0.006)                    |
| 38.10<br>(1.500)          | 38.05<br>(1.498)  | 38.10<br>(1.500)  | 0.33/0.18<br>(0.013/0.007)                    |
| 42.86<br>(1.690)          | 42.81<br>(1.685)  | 42.86<br>(1.687)  | 0.36/0.18<br>(0.014/0.007)                    |
| 49.21<br>(1.940)          | 49.16<br>(1.935)  | 49.21<br>(1.937)  | 0.38/0.23<br>(0.015/0.008)                    |
| 55.56<br>(2.190)          | 55.51<br>(2.185)  | 55.56<br>(2.187)  | 0.41/0.23<br>(0.016/0.009)                    |
| 61.91<br>(2.440)          | 61.86<br>(2.435)  | 61.91<br>(2.437)  | 0.41/0.23<br>(0.016/0.009)                    |
| 68.26<br>(2.690)          | 68.21<br>(2.685)  | 68.26<br>(2.687)  | 0.43/0.23<br>(0.017/0.009)                    |
| 74.61<br>(2.940)          | 74.56<br>(2.935)  | 74.61<br>(2.937)  | 0.43/0.23<br>(0.017/0.009)                    |
| 82.55<br>(3.250)          | 82.47<br>(3.247)  | 82.55<br>(3.250)  | 0.46/0.25<br>(0.018/0.010)                    |
| 88.90<br>(3.500)          | 88.82<br>(3.497)  | 88.90<br>(3.500)  | 0.48/0.28<br>(0.019/0.011)                    |
| 95.25<br>(3.750)          | 95.17<br>(3.747)  | 95.25<br>(3.750)  | 0.53/0.35<br>(0.021/0.012)                    |
| 101.60<br>(4.000)         | 101.58<br>(3.997)   | 101.60<br>(4.000) | 0.56/0.33<br>(0.022/0.013)                    |
| 114.30<br>(4.500)         | 114.22<br>(4.497)   | 114.30<br>(4.500) | 0.58/0.35<br>(0.023/0.014)                    |
| 127.00<br>(5.000)         | 126.92<br>(4.997)   | 127.00<br>(5.000) | 0.61/0.38<br>(0.024/0.015)                    |

Bronze, epoxy, carbon and hard-backed rubber bearings are pressed into their respective bores. They can either be pressed out or machined on the inside diameter until the wall is thin enough to collapse.

Some rubber bearings are the snap-in or glue-in type. These can be removed by prying inward on the outside of the bearing to collapse it.

If the bearing bore of the housing is heavily scarred or corroded, the part should be replaced or reworked to provide a true bore for the bearing.

Replacement bearings are designed to be pressed into housings so bores will shrink to "as new" tolerances. Measure the bore of bearings after pressing and ream as necessary to assure "as new" tolerances.

**6.9.3 Inspection of bowl assembly**

**CAUTION** When repairing a bowl assembly that has been in service for several years, the physical condition or strength of all parts such as cap screws, bowls and bowl threads must be carefully checked.



When attempting to rework any part, extreme care must be taken to maintain alignment of mating parts and ensure “as new” tolerances.

The inspection, disassembly of bowl assembly requires expertise and tools to perform the job correctly. It is recommended to seek the services of Flowserve trained technicians to inspect and repair bowl assemblies.

**6.9.3.1 Inspection of enclosed impellers**

- a) Clear all passageways and check for signs of damage from abrasion or corrosion. Replace an impeller that shows signs of excessive wear.
- b) Check impeller running clearances against “as new” tolerances listed in the section 0. If the clearances exceed the maximum tolerances shown by more than 50%, the new wear rings should be installed to obtain correct tolerances.
- c) If the original unit was furnished with bowl and impeller wear rings, they may be pressed or machined off.

Please note that certain repairs may require special skills and it is recommended to contact Flowserve authorized service center before attempting any such repairs.

See wear ring tolerance chart in section 0.

**6.9.3.2 Inspection of semi-open impellers**

- a) Clear all passageways and check for signs of damage from abrasion or corrosion.
- b) Replace any impeller, which shows signs of excessive wear. If the bowl faces or impellers are worn slightly (grooves in either impeller or bowl under 0.79 mm (1/32 in.)), they can be corrected by re-facing the impeller and bowl. 0.79 mm (1/32 in.) is the maximum that can be machined off without harm to the hydraulic performance of the pump.
- c) The machining must match the face angle and should be re-faced by an authorized Flowserve repair facility or replaced.

If the impeller has a balance ring on the topside (side opposite pumping vanes) running clearances must be checked.

Please see section 6.9.4 for wearing ring tolerance chart for enclosed impellers.

**6.9.4 Wearing ring tolerance chart for enclosed impellers**

| Bowl ring internal diameter. Nominal mm (in.) | Clearance between bowl and impeller wear rings |                           | Bowl ring interference fit | Impeller ring interference fit |
|---|--|---------------------------|----------------------------|--------------------------------|
|   | Standard                                       | Galled                    |                            |                                |
|   | mm (in.)                                       |                           |                            |                                |
| 50.8-76.2 (2-3)                               | 0.330/0.229 (0.013/0.009)                      | 0.533/0.432 (0.021/0.017) | 0.101/0.050 (0.004/0.002)  | 0.076/0.025 (0.003/0.001)      |
| 76.2-101.6 (3-4)                              | 0.356/0.229 (0.014/0.009)                      | 0.635/0.483 (0.025/0.019) | 0.127/0.050 (0.005/0.002)  | 0.102/0.025 (0.004/0.001)      |
| 101.6-127.0 (4-5)                             | 0.381/0.279 (0.015/0.011)                      | 0.635/0.533 (0.025/0.021) | 0.152/0.076 (0.006/0.003)  | 0.127/0.038 (0.005/0.002)      |
| 127.0-152.4 (5-6)                             | 0.406/0.305 (0.016/0.012)                      | 0.660/0.559 (0.026/0.022) | 0.178/0.076 (0.007/0.003)  | 0.127/0.038 (0.005/0.002)      |
| 152.4-177.8 (6-7)                             | 0.406/0.305 (0.016/0.012)                      | 0.686/0.584 (0.027/0.023) | 0.178/0.076 (0.007/0.003)  | 0.127/0.038 (0.005/0.002)      |
| 177.8-203.2 (7-8)                             | 0.432/0.330 (0.017/0.013)                      | 0.711/0.610 (0.028/0.024) | 0.203/0.076 (0.008/0.003)  | 0.152/0.051 (0.006/0.002)      |
| 203.2-228.2 (8-9)                             | 0.457/0.356 (0.018/0.014)                      | 0.737/0.635 (0.029/0.025) | 0.254/0.102 (0.010/0.004)  | 0.178/0.051 (0.007/0.002)      |
| 228.2-254.0 (9-10)                            | 0.457/0.356 (0.018/0.014)                      | 0.762/0.660 (0.030/0.026) | 0.254/0.102 (0.010/0.004)  | 0.229/0.051 (0.009/0.002)      |
| 254.0-279.4 (10-11)                           | 0.457/0.356 (0.018/0.014)                      | 0.788/0.686 (0.031/0.027) | 0.254/0.102 (0.010/0.004)  | 0.229/0.076 (0.009/0.003)      |
| 279.4-304.8 (11-12)                           | 0.457/0.356 (0.018/0.014)                      | 0.813/0.711 (0.032/0.028) | 0.280/0.102 (0.011/0.004)  | 0.229/0.076 (0.009/0.003)      |
| 304.8-330.2 (12-13)                           | 0.508/0.356 (0.020/0.014)                      | 0.890/0.737 (0.035/0.029) | 0.280/0.102 (0.011/0.004)  | 0.229/0.076 (0.009/0.003)      |
| 330.2-355.6 (13-14)                           | 0.508/0.356 (0.020/0.014)                      | 0.914/0.762 (0.036/0.030) | 0.305/0.102 (0.012/0.004)  | 0.254/0.102 (0.010/0.004)      |
| 355.6-381.0 (14-15)                           | 0.508/0.356 (0.020/0.014)                      | 0.940/0.788 (0.037/0.031) | 0.305/0.127 (0.012/0.005)  | 0.254/0.102 (0.010/0.004)      |
| 381.0-406.4 (15-16)                           | 0.559/0.406 (0.022/0.016)                      | 0.965/0.813 (0.038/0.032) | 0.305/0.127 (0.012/0.005)  | 0.254/0.102 (0.010/0.004)      |
| 406.4-431.8 (16-17)                           | 0.559/0.406 (0.022/0.016)                      | 0.990/0.838 (0.039/0.033) | 0.305/0.127 (0.012/0.005)  | 0.254/0.102 (0.010/0.004)      |
| 431.8-457.2 (17-18)                           | 0.610/0.457 (0.024/0.018)                      | 1.010/0.864 (0.040/0.034) | 0.305/0.127 (0.012/0.005)  | 0.254/0.102 (0.010/0.004)      |
| 457.2-482.6 (18-19)                           | 0.610/0.457 (0.024/0.018)                      | 1.041/0.889 (0.041/0.035) | 0.330/0.406 (0.013/0.016)  | 0.279/0.127 (0.011/0.005)      |
| 482.6-508.0 (19-20)                           | 0.610/0.457 (0.024/0.018)                      | 1.070/0.914 (0.042/0.036) | 0.330/0.406 (0.013/0.016)  | 0.279/0.127 (0.011/0.005)      |
| 508.0-533.4 (20-21)                           | 0.660/0.508 (0.026/0.020)                      | 1.092/0.934 (0.043/0.037) | 0.356/0.152 (0.014/0.006)  | 0.305/0.127 (0.012/0.005)      |
| 533.4-558.8 (21-22)                           | 0.660/0.508 (0.026/0.020)                      | 1.118/0.965 (0.044/0.038) | 0.356/0.152 (0.014/0.006)  | 0.304/0.127 (0.012/0.005)      |
| 558.8-584.2 (22-23)                           | 0.660/0.508 (0.026/0.020)                      | 1.143/0.990 (0.045/0.039) | 0.356/0.152 (0.014/0.006)  | 0.304/0.127 (0.012/0.005)      |
| 584.2-609.6 (23-24)                           | 0.660/0.508 (0.026/0.020)                      | 1.168/1.020 (0.046/0.040) | 0.381/0.179 (0.015/0.007)  | 0.330/0.152 (0.013/0.006)      |
| 609.6-635.0 (24-25)                           | 0.660/0.508 (0.026/0.020)                      | 1.194/1.041 (0.047/0.041) | 0.406/0.179 (0.016/0.007)  | 0.330/0.152 (0.013/0.006)      |
| 635.0-660.4 (25-26)                           | 0.660/0.508 (0.026/0.020)                      | 1.220/1.066 (0.048/0.042) | 0.406/0.203 (0.016/0.008)  | 0.356/0.179 (0.014/0.007)      |
| 660.4-685.8 (26-27)                           | 0.660/0.508 (0.026/0.020)                      | 1.244/1.092 (0.049/0.043) | 0.406/0.203 (0.016/0.008)  | 0.356/0.179 (0.014/0.007)      |



## 6.10 Assembly

To assemble the pump consult the sectional drawings.

**Note:** The pump that has been purchased may have order specific assembly and parts configurations. Specific cross sectional drawings that reflect the exact pump/parts details can be purchased from Flowserve. Contact Flowserve for drawings purchase and cost information.

It is recommended to call for trained Flowserve technicians for all your assembly needs.



Refer to seal manufacturer's instructions for disassembly and re-assembly of mechanical seals.



Please take precaution during assembly process such that there is no risk of explosion due to the nature of the materials/ tools/ equipment/ methods used. Wherever chemicals and hazardous materials are involved, proper safety rules must be followed to prevent any dangers to human lives or livestock. Refer to applicable local regulatory agency requirements for specific safety information.

## 7 FAULTS; CAUSES AND REMEDIES

### FAULT SYMPTOM

|                               |                                   |  |         |  |                   |  |   |  |  |
|-------------------------------|-----------------------------------|--|---------|--|-------------------|--|---|--|--|
| Pump overheats and seizes     |                                   |  |         |  |                   |  |   |  |  |
| ↓                             | Bearings have short life          |  |         |  |                   |  |   |  |  |
| ↓                             | Pump vibrates or is noisy         |  |         |  |                   |  |   |  |  |
| ↓                             | Mechanical seal has short life    |  |         |  |                   |  |   |  |  |
| ↓                             | Mechanical seal leaks excessively |  |         |  |                   |  |   |  |  |
| ↓                             | Pump requires excessive power     |  |         |  |                   |  |   |  |  |
| ↓                             | Pump loses prime after starting   |  |         |  |                   |  |   |  |  |
| ↓                             | Insufficient pressure developed   |  |         |  |                   |  |   |  |  |
| ↓                             | Insufficient capacity delivered   |  |         |  |                   |  |   |  |  |
| ↓                             | Pump does not deliver liquid      |  |         |  |                   |  |   |  |  |
| ↓                             | POSSIBLE CAUSES                   |  |         |  | POSSIBLE REMEDIES |  |   |  |  |
| <b>A. SYSTEM PROBLEMS</b>     |                                   |  |         |  |                   |  |   |  |  |
| ●                             |                                   |  |         |  | ● ●               | Pump not submerged.  | Check requirements/liquid level. Vent and/or prime.   |  |  |
|                               | ●                                 |  |         |  | ● ●               | Impeller not adjusted or loose on shaft.                         | See PART/2-Section A7 for proper impeller adjustment.   |  |  |
|                               | ●                                 |  |         |  | ● ●               | Suction lift too high or level too low.                          | Check NPSHa>NPSHr, proper submergence, losses at strainers/fittings.  |  |  |
| ●                             | ●                                 |  |         |  | ● ●               | Insufficient margin between suction pressure and vapor pressure. |   |  |  |
|                               |                                   |  |         |  | ● ● ●             | Excessive amount of air or gas in liquid.                        | Check and purge pipes and system.   |  |  |
|                               |                                   |  |         |  | ●                 | Line check valve backward/stuck.                                 | Reverse chuck valve /free the valve.  |  |  |
|                               |                                   |  |         |  | ●                 | Unit running backwards.  | See start up instruction. Check motor phase/wiring  |  |  |
|                               | ●                                 |  |         |  | ● ●               | Air or vapor pocket in suction line.                             | Check suction line design for vapor pockets.  |  |  |
|                               |                                   |  |         |  | ● ●               | Air leaks into suction line.                                     | Check suction pipe is airtight.   |  |  |
|                               | ●                                 |  |         |  | ● ●               | Intake strainer or impeller plugged or pump in mud or sand.      | Start and stop several times or use line pressure if available to back flush or pull pump to clean.         |  |  |
|                               | ●                                 |  |         |  | ● ●               | Inlet of suction pipe insufficiently submerged.                  | Check out system design.  |  |  |
|                               |                                   |  |         |  | ● ● ●             | Speed too low.   | Consult Flowserve.  |  |  |
|                               |                                   |  | ● ●     |  |                   | Speed too high.  | Consult Flowserve.  |  |  |
|                               |                                   |  |         |  | ● ● ●             | Total head of system higher than differential head of pump.      | Check system losses or consult Flowserve.   |  |  |
|                               |                                   |  | ●       |  |                   | Total system head is lower than pump design head.                |   |  |  |
|                               |                                   |  | ● ●     |  |                   | Specific gravity of liquid different from design.                | Check and consult Flowserve. Check the pump design for the type of liquid to be handled. Consult Flowserve. |  |  |
|                               |                                   |  | ● ● ● ● |  |                   | Viscosity of liquid differs from the designed.                   |   |  |  |
| ●                             | ●                                 |  |         |  |                   | Operation at very low capacity.                                  | Measure. Check minimum permitted. Consult Flowserve.  |  |  |
|                               | ● ●                               |  | ● ●     |  |                   | Operation at high capacity.                                      | Measure value and check maximum permitted. Consult Flowserve.   |  |  |
| <b>B. MECHANICAL PROBLEMS</b> |                                   |  |         |  |                   |  |   |  |  |
| ● ● ● ● ● ●                   |                                   |  |         |  |                   | Misalignment due to pipe strain.                                 | Check the flange connections and eliminate strains using elastic couplings or a method permitted.           |  |  |
|                               | ●                                 |  |         |  |                   | Improperly designed foundation./Loose fasteners.                 | Check setting of base plate. Tighten, adjust, grout base as required. Check fasteners and torque.           |  |  |
|                               | ● ● ● ● ●                         |  |         |  |                   | Shaft bent.  | Check shaft run outs. Consult Flowserve.  |  |  |
| ● ● ● ● ● ●                   |                                   |  | ● ●     |  |                   | Rotating part rubbing on stationary part.                        | Check. Consult Flowserve, if necessary.   |  |  |
| ● ● ● ● ● ●                   |                                   |  |         |  |                   | Bearings worn.   | Replace bearings.   |  |  |
|                               |                                   |  | ● ● ●   |  |                   | Wearing ring surfaces worn.                                      | Replace worn wear ring/surfaces.  |  |  |

**FAULT SYMPTOM**

|                                     |                          |                           |                                |                                   |                               |                                 |   |   |  |                          |  |   |
|-------------------------------------|--------------------------|---------------------------|--------------------------------|-----------------------------------|-------------------------------|---------------------------------|---|---|--|--------------------------|--|---|
| Pump overheats and seizes           |                          |                           |                                |                                   |                               |                                 |   |   |  |                          |  |   |
| ↓                                   | Bearings have short life |                           |                                |                                   |                               |                                 |   |   |  |                          |  |   |
| ↓                                   | ↓                        | Pump vibrates or is noisy |                                |                                   |                               |                                 |   |   |  |                          |  |   |
| ↓                                   | ↓                        | ↓                         | Mechanical seal has short life |                                   |                               |                                 |   |   |  |                          |  |   |
| ↓                                   | ↓                        | ↓                         | ↓                              | Mechanical seal leaks excessively |                               |                                 |   |   |  |                          |  |   |
| ↓                                   | ↓                        | ↓                         | ↓                              | ↓                                 | Pump requires excessive power |                                 |   |   |  |                          |  |   |
| ↓                                   | ↓                        | ↓                         | ↓                              | ↓                                 | ↓                             | Pump loses prime after starting |   |   |  |                          |  |   |
| ↓                                   | ↓                        | ↓                         | ↓                              | ↓                                 | ↓                             | Insufficient pressure developed |   |   |  |                          |  |   |
| ↓                                   | ↓                        | ↓                         | ↓                              | ↓                                 | ↓                             | Insufficient capacity delivered |   |   |  |                          |  |   |
| ↓                                   | ↓                        | ↓                         | ↓                              | ↓                                 | ↓                             | Pump does not deliver liquid    |   |   |  |                          |  |   |
|                                     |                          |                           |                                |                                   |                               | <b>POSSIBLE CAUSES</b>          |   |   |  | <b>POSSIBLE REMEDIES</b> |  |   |
|                                     |                          | ●                         |                                |                                   |                               | ●                               | ● |   |  |                          | Impeller damaged or eroded.  | Replace. or consult Flowserve for an upgrade.   |
|                                     |                          |                           |                                | ●                                 |                               |                                 |   |   |  |                          | Leakage under sleeve due to joint failure.   | Replace joint and check for damage.   |
|                                     |                          |                           | ●                              | ●                                 |                               |                                 |   |   |  |                          | Shaft sleeve worn, scored, or running off center.  | Check and renew defective parts.  |
|                                     |                          |                           | ●                              | ●                                 | ●                             |                                 |   |   |  |                          | Mechanical seal improperly installed.  | Check alignment of faces/damaged parts/assembly   |
|                                     |                          |                           | ●                              | ●                                 | ●                             |                                 |   |   |  |                          | Incorrect type of mechanical seal.   | Consult Flowserve.  |
| ●                                   |                          | ●                         | ●                              | ●                                 |                               |                                 |   |   |  |                          | Shaft running off center because of worn bearings or misalignment.   | Check misalignment and correct if necessary. If alignment satisfactory check bearings for excessive wear.   |
| ●                                   |                          | ●                         | ●                              | ●                                 |                               |                                 |   |   |  |                          | Impeller out of balance resulting in vibration.  | Check. Consult Flowserve for problem resolution ideas.  |
|                                     |                          | ●                         | ●                              | ●                                 | ●                             |                                 |   |   |  |                          | Solids/Abrasive particles in liquid pumped.  |   |
|                                     |                          |                           | ●                              | ●                                 |                               |                                 |   |   |  |                          | Internal misalignment of parts preventing seal ring and seat from mating properly.                         |   |
|                                     |                          |                           |                                | ●                                 | ●                             |                                 |   |   |  |                          | Mechanical seal was run dry.   | Check mechanical seal/flush supply/pump and repair.   |
|                                     |                          |                           | ●                              | ●                                 | ●                             |                                 |   |   |  |                          | Internal misalignment due to improper repairs causing impeller to rub.                                     | Check method of assembly, possible damage or state of cleanliness during assembly. Check and consult Flowserve, if necessary.                           |
| ●                                   | ●                        | ●                         |                                |                                   |                               |                                 |   |   |  |                          | Excessive thrust caused by a mechanical failure inside the pump.   | Check wear condition of impeller, its clearances and liquid passages.   |
|                                     | ●                        | ●                         |                                |                                   |                               |                                 |   |   |  |                          | Excessive grease in ball bearings.   | Check method of re-greasing.  |
|                                     | ●                        | ●                         |                                |                                   |                               |                                 |   |   |  |                          | Lack of lubrication for bearings.  | Check hours run since last change of lubricant, the schedule and its basis.   |
|                                     | ●                        | ●                         |                                |                                   |                               |                                 |   |   |  |                          | Improper installation of bearings (damage during assembly, incorrect assembly, wrong type of bearing etc). | Check method of assembly, possible damage or state of cleanliness during assembly and type of bearing used. Remedy and consult Flowserve, if necessary. |
|                                     | ●                        | ●                         |                                |                                   |                               |                                 |   |   |  |                          | Damaged bearings due to contamination.   | Check contamination source and replace bearings.  |
| <b>C. MOTOR/ELECTRICAL PROBLEMS</b> |                          |                           |                                |                                   |                               |                                 |   |   |  |                          |  |   |
|                                     |                          | ●                         |                                | ●                                 | ●                             | ●                               | ● |   |  |                          | Wrong direction of rotation.   | Reverse 2 phases at motor terminal box.   |
|                                     | ●                        |                           |                                |                                   |                               |                                 |   |   |  |                          | Motor Protector open.  | Check nameplate for voltage and current rating. Replace faulty motor protectors.  |
|                                     |                          |                           |                                |                                   | ●                             |                                 |   |   |  |                          | Line voltage not correct/faulty control box/wiring/low voltage.  | Check wiring diagram.   |
|                                     | ●                        |                           |                                |                                   |                               |                                 |   |   |  |                          | Blown fuse/breaker open/dead motor/short or loose connection.  | Check/repair or replace fuses/breakers.   |
|                                     |                          |                           |                                | ●                                 |                               |                                 |   | ● |  |                          | Motor running on 2 phases only.  | Check supply and fuses.   |
|                                     | ●                        | ●                         |                                |                                   |                               |                                 |   | ● |  |                          | Motor running too slow.  | Check motor terminal box connections and voltage.   |

## 8 DRAWINGS AND PARTS LISTS

**Note:** Please refer to appendix for Europump part number equivalents.

### 8.1 Cross Section: Product Lubricated VTP Typical wet pit pump

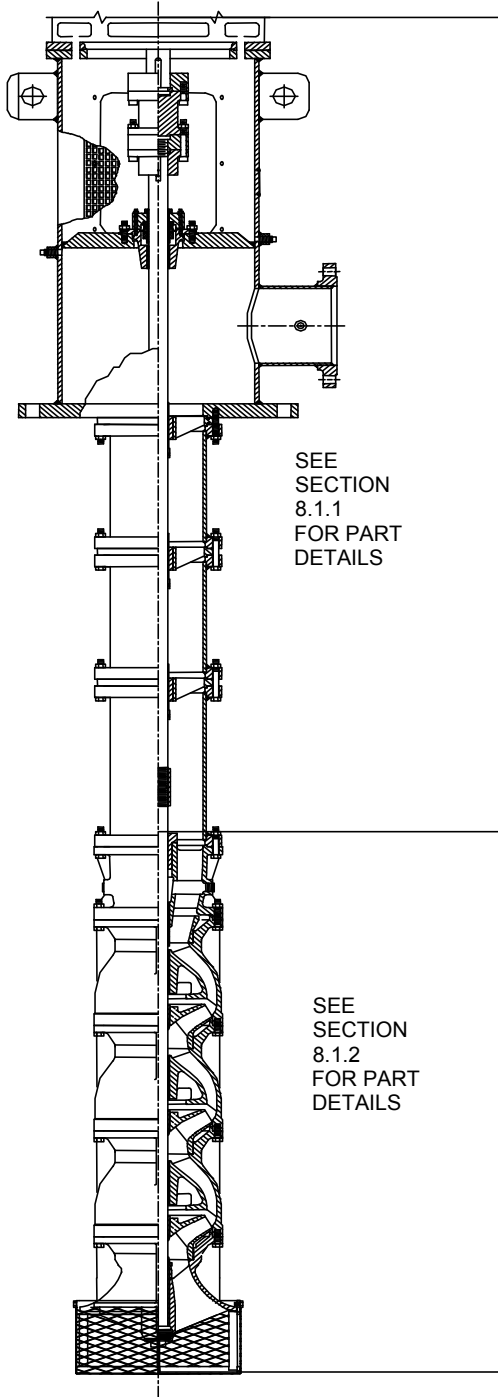

See sections 8.1.1 and 8.1.2 for parts details

**Note:** All the sectional drawings provided in this section are typical representations of the most common pump types and are provided for the purposes of basic understanding of the equipment. The details shown may not reflect the specifics of the pump that has been purchased. Order-specific cross sectional drawings and parts list can be purchased from Flowserve separately. Contact Flowserve for ordering and pricing information on such drawings and documentation.

8.1.1 **Parts identification: Discharge head and column assembly**  
 Typical wet pit/sump type design-product lubricated VTP

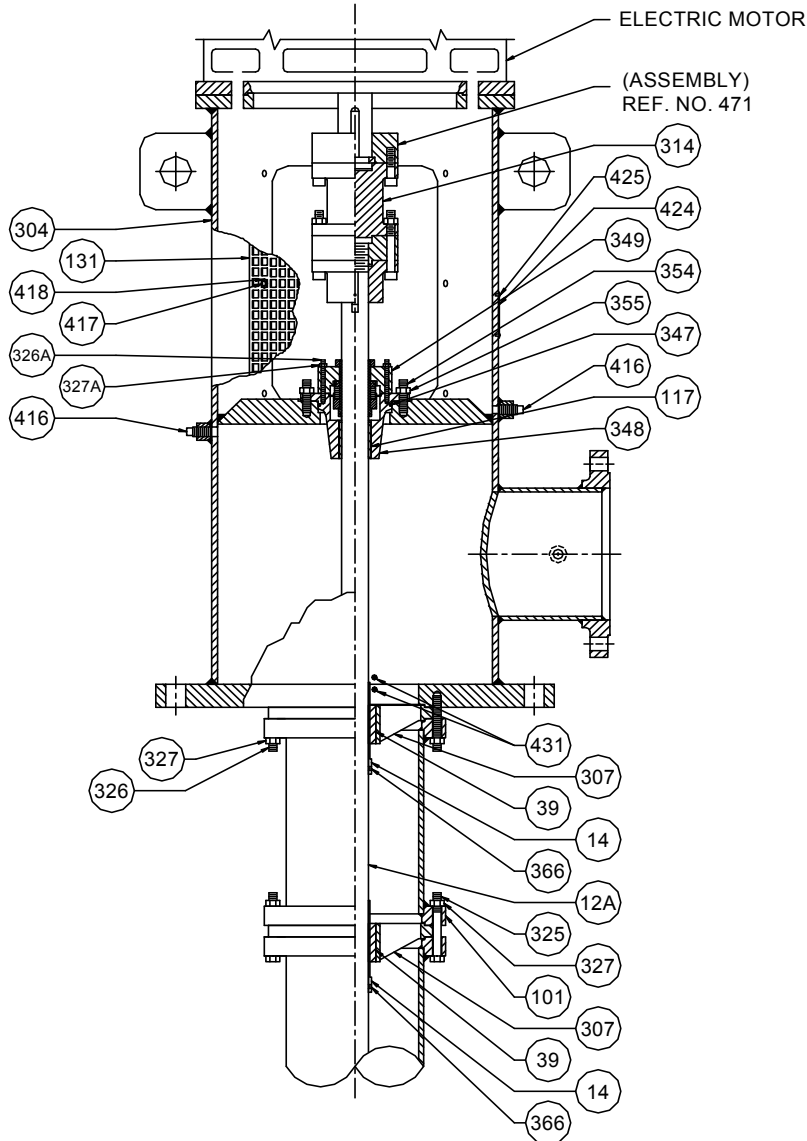

8.1.1.1 **Parts list-Discharge head and column assembly**

| Ref no. | Description                     |
|---------|---------------------------------|
| 12A     | SHAFT-TOP                       |
| 14      | SLEEVE-LINESHAFT                |
| 39      | BEARING-SLEEVE-LINESHAFT        |
| 101     | COLUMN-PIPE-REG                 |
| 117     | BEARING-SLEEVE-THROTTLE BUSHING |
| 131     | GUARD-COUPLING                  |
| 304     | HEAD-DISCHARGE                  |
| 307     | RETAINER-BEARING                |
| 314     | SPACER-FLANGED                  |
| 325     | SCREW-CAP-HEX HEAD              |
| 326     | STUD-THREADED                   |
| 326A    | STUD-THREADED                   |

|      |                                  |
|------|----------------------------------|
| 327  | NUT-HEX                          |
| 327A | NUT-HEX                          |
| 347  | O-RING-STUFFING BOX              |
| 348  | HOUSING-THROTTLE BUSHING         |
| 349  | SEAL-MECHANICAL                  |
| 354  | STUD-THREADED                    |
| 355  | NUT-HEX                          |
| 366  | SCREW-SET                        |
| 416  | PLUG-PIPE                        |
| 417  | SCREW-CAP-HEX HEAD               |
| 418  | WASHER                           |
| 424  | NAMEPLATE-FLS                    |
| 425  | DRIVE SCREW FOR SERIAL PLATE     |
| 431  | O-RING                           |
| 471  | ASSEMBLY, MOTOR TO PUMP COUPLING |

8.1.2 Parts identification: Bowl assembly  
 Typical wet pit/sump type design-product  
 lubricated VTP

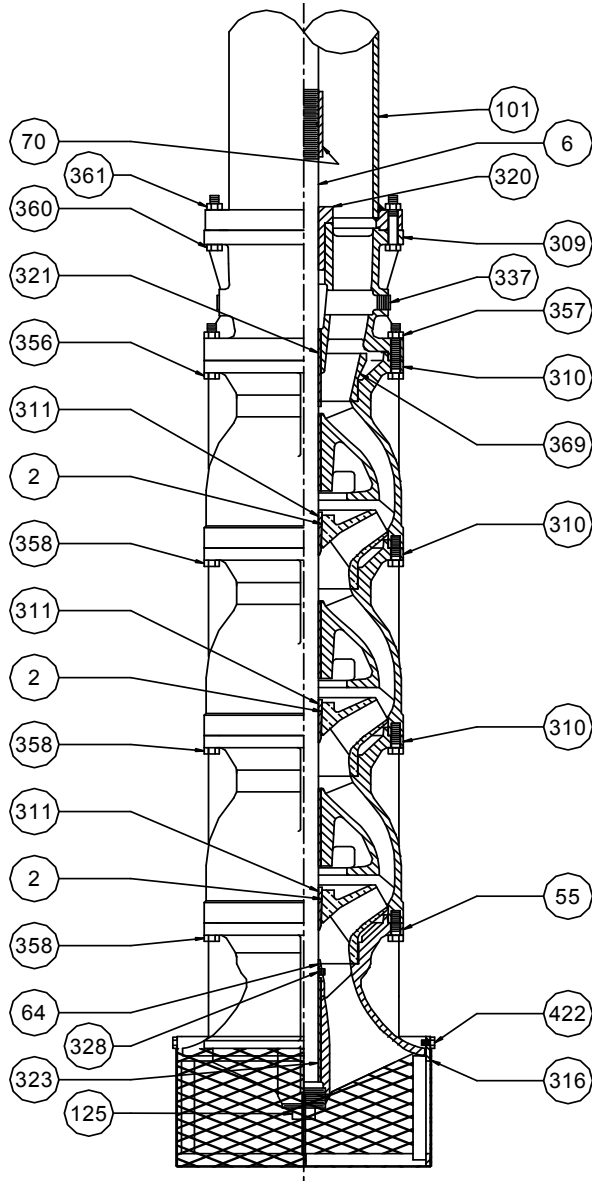

8.1.2.1 Parts list-Bowl assembly

| Ref no. | Description                     |
|---------|---------------------------------|
| 2       | IMPELLER                        |
| 6       | SHAFT-PUMP                      |
| 55      | BELL-SUCTION                    |
| 64      | COLLAR-PROTECTIVE               |
| 70      | COUPLING-SHAFT-THREADED         |
| 101     | COLUMN-PIPE-REG                 |
| 125     | PLUG-GREASE                     |
| 309     | CASE-DISCHARGE                  |
| 310     | BOWL                            |
| 311     | COLLET-DRIVE                    |
| 316     | STRAINER                        |
| 320     | BEARING-THREADED-DISCHARGE CASE |
| 321     | BEARING-SLEEVE-DISCHARGE CASE   |
| 323     | BEARING-SLEEVE-BELL             |
| 328     | SCREW-SET                       |
| 337     | PLUG-PIPE                       |
| 356     | SCREW-CAP-HEX HEAD              |
| 357     | NUT-HEX                         |
| 358     | SCREW-CAP-HEX HEAD              |
| 360     | SCREW-CAP-HEX HEAD              |
| 361     | NUT-HEX                         |
| 369     | RING-FLOW                       |
| 422     | SCREW-CAP-HEX HEAD              |



**8.2 Cross Section: Enclosed Tube VTP**  
 Typical enclosed tube/oil lubricated VTP

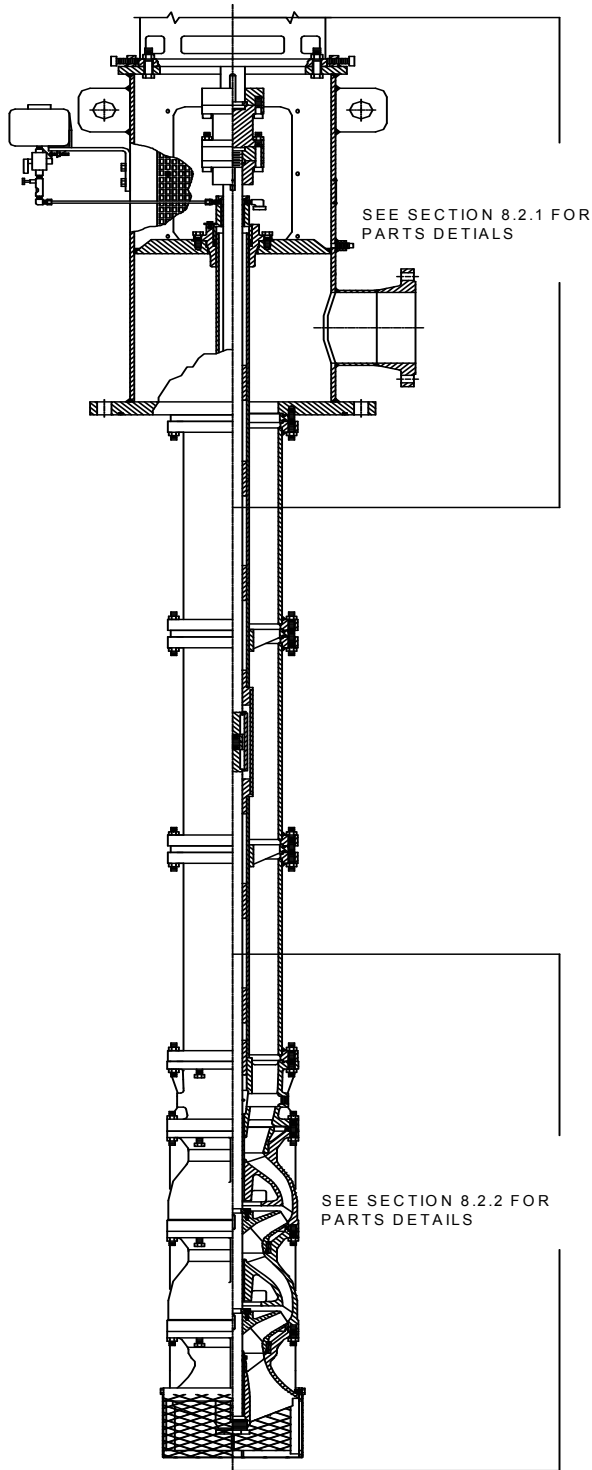

See sections 8.2.1 and 8.2.2 for parts details.

**Note:** *All the sectional drawings provided in this section are typical representations of the most common pump types and are provided for the purposes of basic understanding of the equipment. The details shown may not reflect the specifics of the pump that has been purchased. Order-specific cross sectional drawings and parts list can be purchased from Flowserve separately. Contact Flowserve for ordering and pricing information on such drawings and documentation.*

8.2.1 **Parts identification: Typical enclosed shaft and oil lube connections**  
**Typical enclosed tube/oil lubricated VTP**

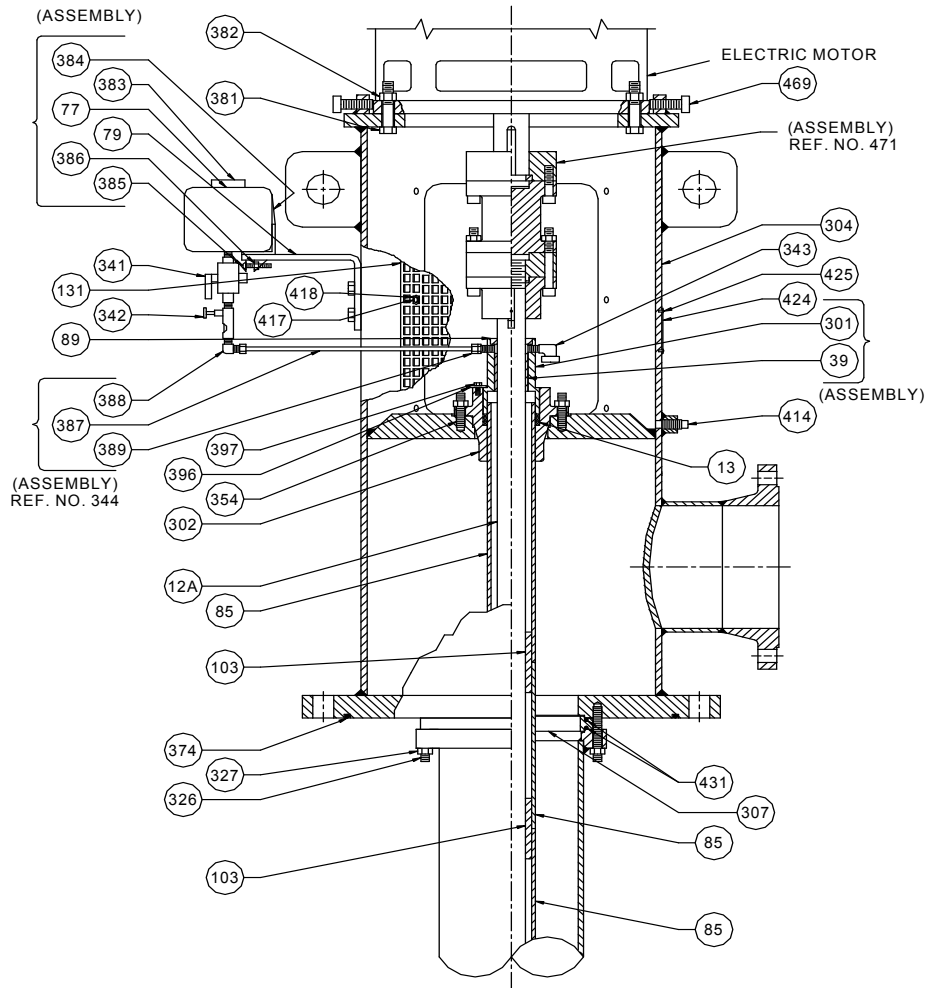

8.2.1.1 **Parts list-Enclosed shaft and oil lube connections**

| Ref no. | Description                 |
|---------|-----------------------------|
| 12A     | SHAFT-TOP                   |
| 13      | PACKING SET                 |
| 39      | BEARING-SLEEVE-LINESHAFT    |
| 77      | OIL TANK                    |
| 79      | BRACKET                     |
| 85      | ENCLOSING TUBE              |
| 89      | SEAL-OIL                    |
| 103     | BEARING-THREADED-LINE SHAFT |
| 131     | GUARD-COUPLING              |
| 301     | ENCLOSING TUBE NUT          |
| 302     | TUBE-TENSION                |
| 304     | HEAD-DISCHARGE              |
| 307     | RETAINER-BEARING            |
| 326     | STUD-THREADED               |
| 327     | NUT-HEX                     |
| 341     | VALVE-SHUTOFF               |
| 342     | REGULATOR-SIGHT FEED        |
| 343     | ELBOW-VENT                  |
| 354     | STUD-THREADED               |

|     |                                  |
|-----|----------------------------------|
| 374 | O-RING-BARREL                    |
| 381 | SCREW-CAP-HEX HEAD               |
| 382 | NUT-HEX                          |
| 383 | CAP                              |
| 384 | BAND                             |
| 385 | STOVE BOLT                       |
| 386 | NUT-HEX                          |
| 387 | LUBRICATION LINE                 |
| 388 | FITTING-ELBOW                    |
| 389 | FITTING-ADAPTER                  |
| 396 | CLIP-SAFETY                      |
| 397 | SCREW-CAP-HEX HEAD               |
| 414 | PLUG-PIPE                        |
| 417 | SCREW-CAP-HEX HEAD               |
| 418 | WASHER                           |
| 424 | SERIAL PLATE-FLOWSERVE TANEYTOWN |
| 425 | DRIVE SCREW FOR SERIAL PLATE     |
| 431 | O-RING                           |
| 469 | SCREW-CAP-HEX HEAD               |

8.2.2 **Parts identification: Bowl and enclosing tube assembly**  
**Typical enclosed tube/oil lubricated VTP**

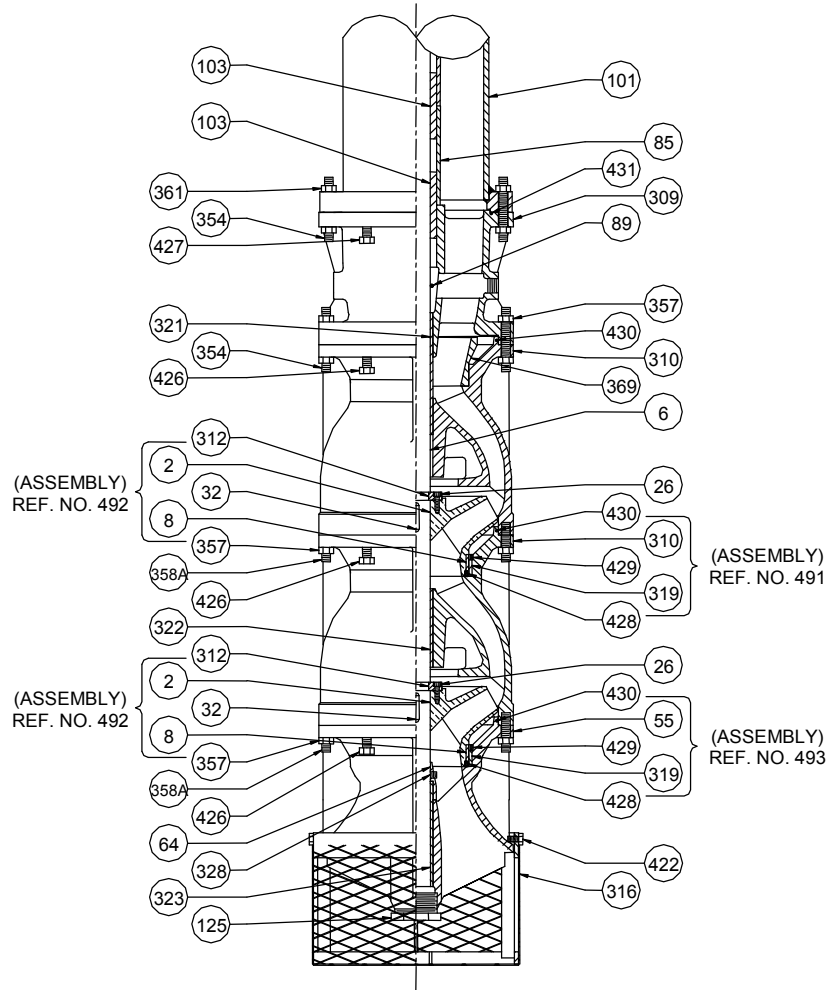

8.2.2.1 **Parts list-Bowl and enclosing tube assembly.**

| Ref no. | Description                 |
|---------|-----------------------------|
| 2       | IMPELLER                    |
| 6       | SHAFT-PUMP                  |
| 8       | RING-WEAR-IMPELLER          |
| 26      | SCREW-CAP SOCKET HEAD       |
| 32      | KEY-STRAIGHT                |
| 39      | BEARING-SLEEVE-LINESHAFT    |
| 55      | BELL-SUCTION                |
| 64      | COLLAR-PROTECTIVE           |
| 85      | ENCLOSING TUBE              |
| 89      | SEAL-OIL                    |
| 101     | COLUMN-PIPE-REG             |
| 103     | BEARING-THREADED-LINE SHAFT |
| 125     | PLUG-GREASE                 |
| 309     | CASE-DISCHARGE              |
| 310     | BOWL                        |
| 311     | COLLET-DRIVE                |
| 312     | RING-THRUST-SPLIT-IMPELLER  |
| 312*    | RING-THRUST-SPLIT-COUPLING  |

|      |                                  |
|------|----------------------------------|
| 316  | STRAINER                         |
| 319  | RING-WEAR-BOWL                   |
| 319* | RING-WEAR-BOWL                   |
| 321  | BEARING-SLEEVE-DISCHARGE CASE    |
| 322  | BEARING-SLEEVE-BOWL              |
| 323  | BEARING-SLEEVE-BELL              |
| 328  | SCREW-SET                        |
| 354  | STUD-THREADED                    |
| 357  | NUT-HEX                          |
| 358A | STUD-THREADED                    |
| 361  | NUT-HEX                          |
| 369  | RING-FLOW                        |
| 422  | SCREW-CAP-HEX HEAD               |
| 426  | SCREW-CAP-HEX HEAD               |
| 427  | SCREW-CAP-HEX HEAD (JACKING LUG) |
| 428  | PIN-ROLL                         |
| 429  | PIN-ROLL                         |
| 430  | O-RING                           |
| 431  | O-RING                           |

### 8.3 Cross Section: Suction Barrel VTP Typical

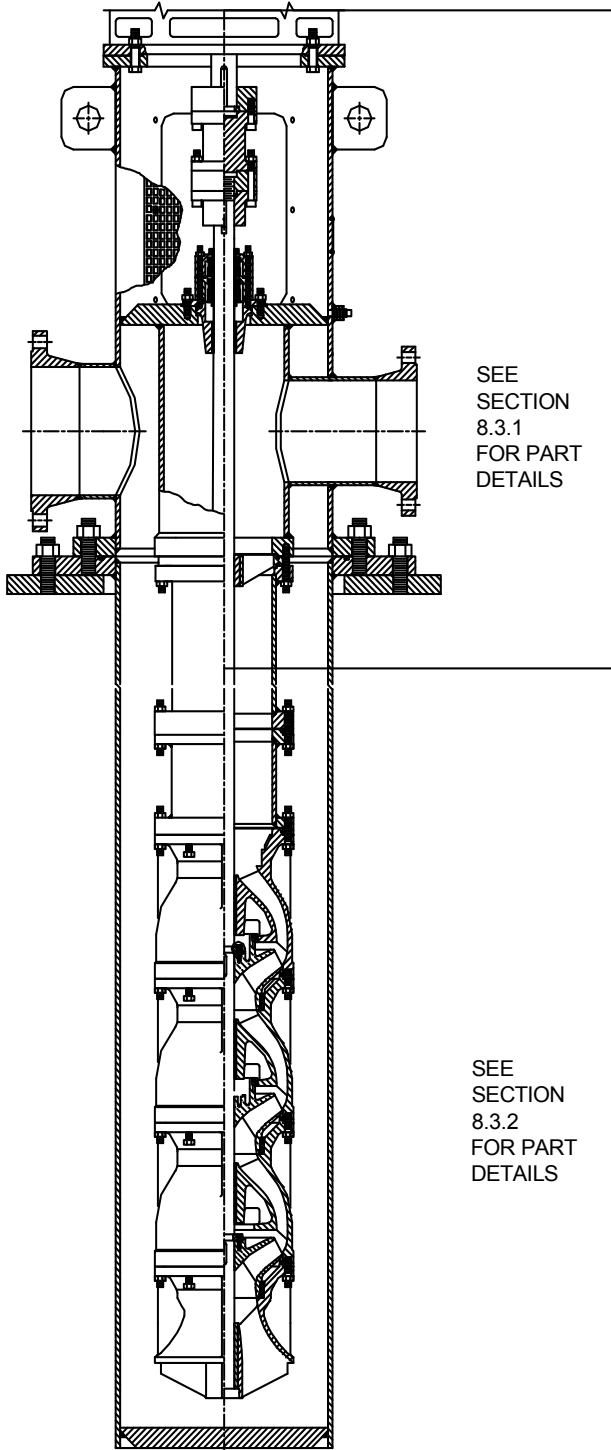

SEE  
SECTION  
8.3.1  
FOR PART  
DETAILS

SEE  
SECTION  
8.3.2  
FOR PART  
DETAILS

See sections 8.3.1 and 8.3.2 for parts details

**Note:**

*All the sectional drawings provided in this section are typical representations of the most common pump types and are provided for the purposes of basic understanding of the equipment. The details shown may not reflect the specifics of the pump that has been purchased. Order-specific cross sectional drawings and parts list can be purchased from Flowserve separately. Contact Flowserve for ordering and pricing information on such drawings and documentation.*

8.3.1 **Parts identification: Discharge head/column/suction barrel**  
 Typical product lubricated VTP with a suction barrel

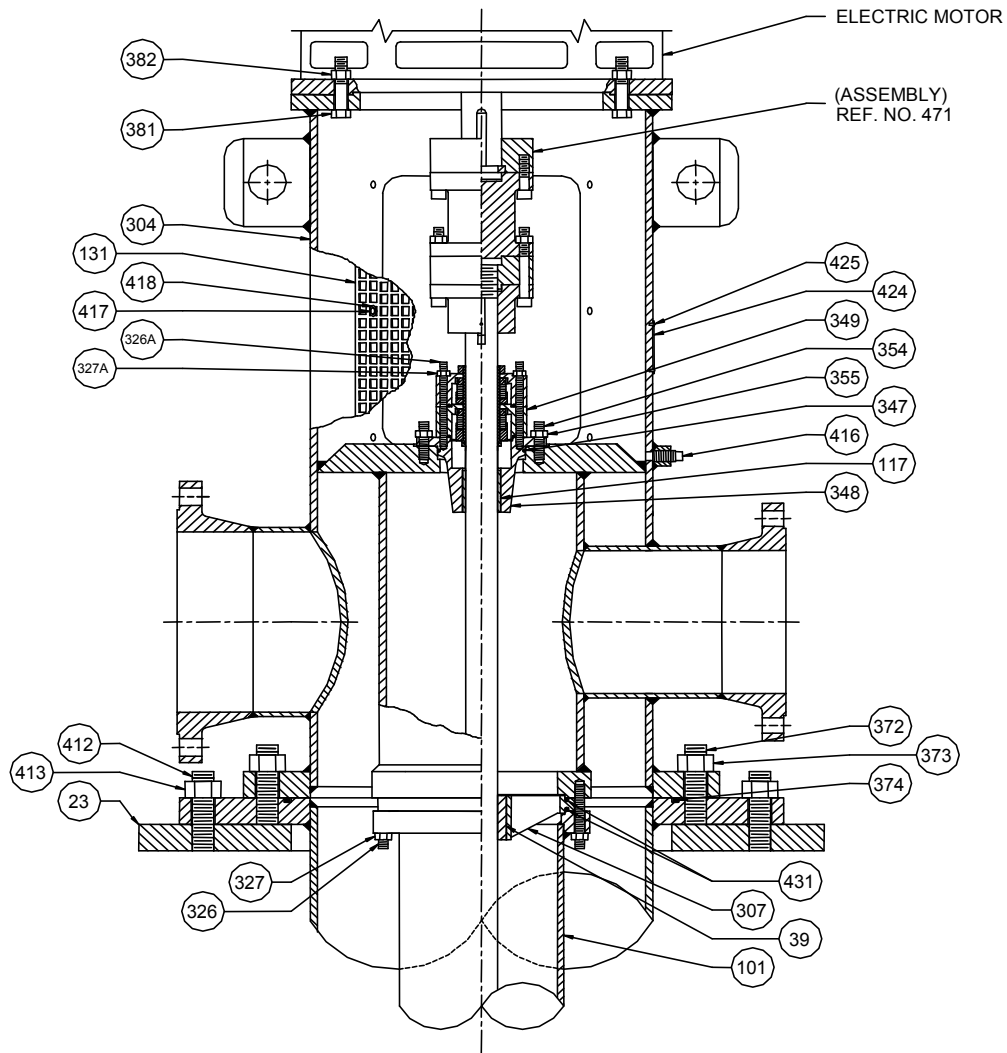

8.3.1.1 **Parts list-Discharge head/column/suction barrel**

| Ref no. | Description                     |
|---------|---------------------------------|
| 23      | PLATE-SOLE                      |
| 39      | BEARING-SLEEVE-LINESHAFT        |
| 101     | COLUMN-PIPE-REG                 |
| 117     | BEARING-SLEEVE-THROTTLE BUSHING |
| 131     | GUARD-COUPLING                  |
| 304     | HEAD-DISCHARGE                  |
| 307     | RETAINER-BEARING                |
| 326     | STUD-THREADED                   |
| 326A    | STUD-THREADED                   |
| 327     | NUT-HEX                         |
| 327A    | NUT-HEX                         |
| 347     | O-RING-STUFFING BOX             |
| 348     | HOUSING-THROTTLE BUSHING        |
| 349     | SEAL-MECHANICAL                 |

|     |                              |
|-----|------------------------------|
| 354 | STUD-THREADED                |
| 355 | NUT-HEX                      |
| 372 | STUD-THREADED                |
| 373 | NUT-HEX                      |
| 374 | O-RING-BARREL                |
| 381 | SCREW-CAP-HEX HEAD           |
| 382 | NUT-HEX                      |
| 412 | STUD-THREADED                |
| 413 | NUT-HEX                      |
| 416 | PLUG-PIPE                    |
| 417 | SCREW-CAP-HEX HEAD           |
| 418 | WASHER                       |
| 424 | DISPLAY NAMEPLATE-FLS        |
| 425 | DRIVE SCREW FOR SERIAL PLATE |
| 431 | O-RING                       |

8.3.2 **Parts identification: Column and bowl assembly**  
 Typical product lubricated VTP with the suction barrel

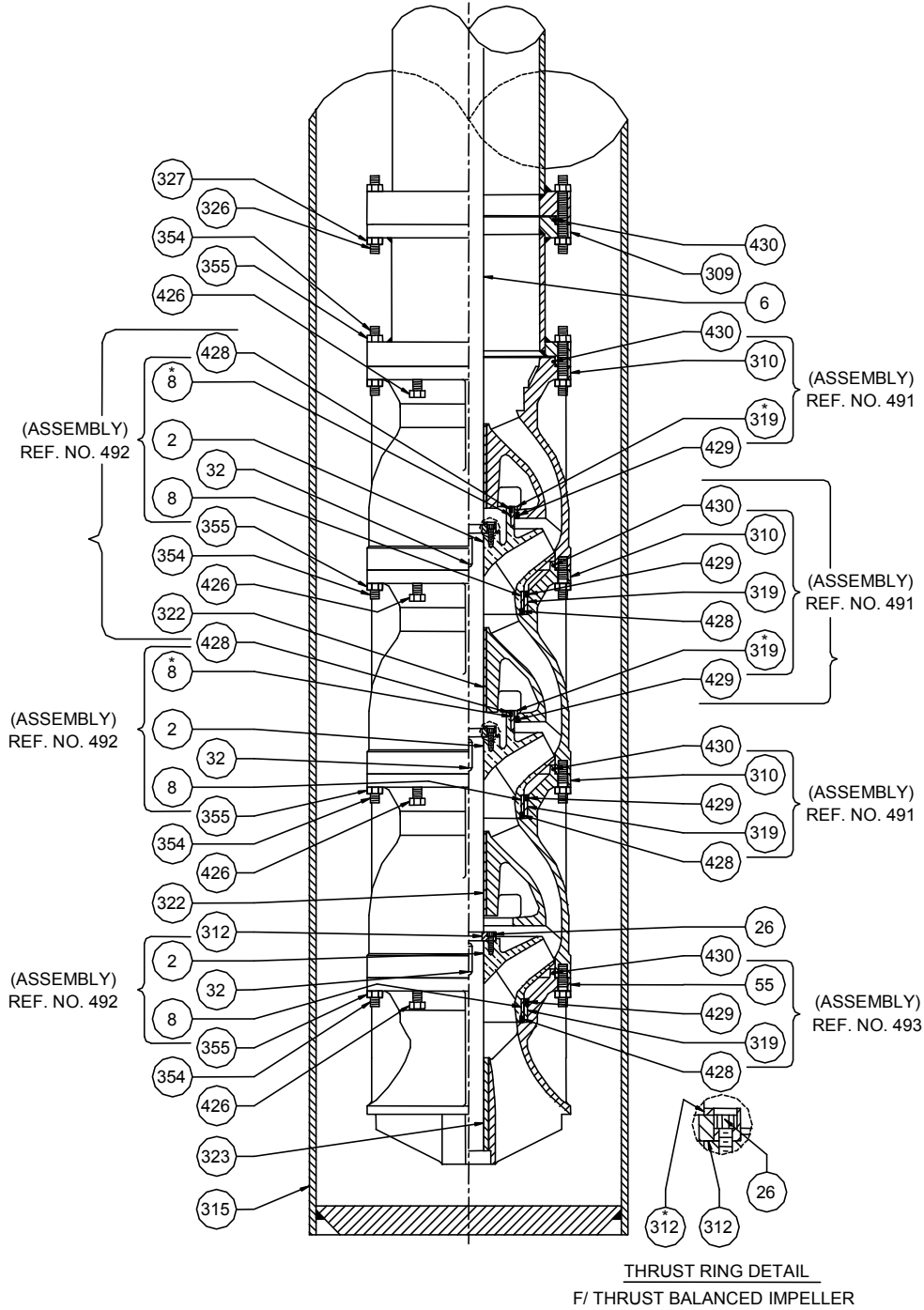



8.3.2.1 **Parts list- Column and bowl assembly**

| Ref no. | Description                        |
|---------|------------------------------------|
| 2       | IMPELLER                           |
| 6       | SHAFT-PUMP                         |
| 8       | RING-WEAR-IMPELLER                 |
| 26      | SCREW-CAP SOCKET HEAD              |
| 32      | KEY-STRAIGHT                       |
| 39      | BEARING-SLEEVE-LINESHAFT           |
| 55      | BELL-SUCTION                       |
| 309     | CASE-DISCHARGE                     |
| 310     | BOWL                               |
| 312     | RING-THRUST-SPLIT-IMPELLER         |
| 312*    | RING-THRUST-SPLIT-COUPLING         |
| 315     | BARREL                             |
| 319*    | RING-WEAR-BOWL                     |
| 322     | BEARING-SLEEVE-BOWL                |
| 323     | BEARING-SLEEVE-BELL                |
| 326     | STUD-THREADED                      |
| 327     | NUT-HEX                            |
| 354     | STUD-THREADED                      |
| 355     | NUT-HEX                            |
| 426     | SCREW-CAP-HEX HEAD                 |
| 428     | PIN-ROLL                           |
| 429     | PIN-ROLL                           |
| 430     | O-RING                             |
| 491     | ASSEMBLY, BOWL                     |
| 492     | ASSEMBLY, WEARING RING             |
| 493     | ASSEMBLY, SUCTION BELL & WEAR RING |

8.4 **General Arrangement Drawing**

The typical general arrangement drawing and any specific drawings required by the contract will be sent to the Purchaser separately unless the contract specifically calls for these to be included into the User Instructions. If these drawings are supplied separately, the purchaser should retain those with the User Instructions.

9 **CERTIFICATION**

Certificates determined from the Contract requirements are provided with these instructions where applicable. Examples are certificates for CE marking and ATEX markings etc. If required, copies of other certificates sent separately to the Purchaser to be retained along with these User instructions.

10 **OTHER RELEVANT DOCUMENTATION AND MANUALS**

10.1 **Supplementary User Instructions**

Supplementary instructions determined from the contract requirements for inclusion into user Instructions such as for a driver, instrumentation, controller, sub-driver, seals, sealant system, mounting component etc are included in the Data Book. If further copies of these are required they should be obtained from the supplier for retention with these user instructions.

Where any pre-printed set of user instructions are used, and satisfactory quality can be maintained only by avoiding copying these, they are included at the end of these user instructions such as within a standard clear polymer software protection envelope.

10.2 **Change Notes**

If any changes, agreed with Flowserve Pump Division, are made to the product after its supply, a record of the details should be maintained with these User Instructions.

## 11 APPENDIX

### 11.1 Bill of Materials Reference Numbers

| Ref. # | Current system description               | Ref. # | Europump terminology 1995 description | Ref. # | Hydraulic institute 2000 description |
|--------|--|--------|---------------------------------------|--------|--------------------------------------|
| 2      | Impeller                                 | 2200   | Impeller                              | 2      | Impeller / propeller                 |
| 2      | Impeller                                 | 2210   | Impeller, suction stage               | 2      | Impeller / propeller                 |
| 6      | Shaft pump                               | 2110   | Pump shaft                            | 6      | Shaft, pump                          |
| 8      | Ring wear impeller                       | 2300   | Impeller wear ring                    | 8      | Ring, impeller                       |
| 10     | Shaft head                               | 2130   | Top shaft / head shaft                | 10     | Shaft, head                          |
| 12     | Shaft line                               | 2120   | Intermediate shaft, drive shaft       | 12     | Shaft, line                          |
| 12     | Shaft top (12a)                          | 2130   | Top shaft / head shaft                | 12     | Shaft, line                          |
| 13     | Packing                                  | 4130   | Packing                               | 13     | Packing                              |
| 14     | Sleeve lineshaft                         | 3400   | Bearing sleeve                        |        |                                      |
| 17     | Gland packing split                      | 4120   | Stuffing box gland                    | 17     | Gland                                |
| 23     | Plate base                               | 6110   | Base plate                            | 129    | Sole plate                           |
| 24     | Nut collet                               |        |                                       |        |                                      |
| 26     | Screw cap socket/head f/imp. Thrust ring | 6579.# | Socket head cap screw                 |        |                                      |
| 29     | Ring lantern                             | 4134   | Lantern ring                          | 29     | Ring, lantern                        |
| 32     | Key impeller                             | 6700.# | Key                                   | 32     | Key, impeller                        |
| 39     | Bearing sleeve f/tube nut                | 4132   | Stuffing box bushing                  | 39     | Bushing, bearing                     |
| 39     | Bearing sleeve lineshaft                 | 3300.# | Bearing, bushing                      | 39     | Bushing, bearing                     |
| 42     | Coupling half driver                     | 7200.1 | Coupling half (driver)                | 42     | Coupling half, driver                |
| 44     | Coupling half driven                     | 7200.2 | Coupling half (driven)                | 44     | Coupling half, pump                  |
| 46     | Key assembly driven coupling half        | 6700.# | Key                                   | 46     | Key, coupling                        |
| 46     | Key driver coupling half                 | 6700.# | Key                                   |        |                                      |
| 55     | Bell suction                             | 1310   | Suction bell                          | 55     | Bell, suction                        |
| 64     | Collar protective                        | 2922   | Sand guard protection collar          | 64     | Collar, protecting                   |
| 66     | Nut adjusting                            | 2909   | Adjusting nut                         | 66     | Nut, shaft, adjusting                |
| 66     | Nut head shaft                           | 2909   | Adjusting nut                         | 66     | Nut, shaft, adjusting                |
| 70     | Coupling shaft (threaded)                | 7119   | Screwed coupling                      | 70     | Coupling, shaft                      |
| 70     | Coupling shaft (keyed)                   | 7020   | Shaft coupling                        | 70     | Coupling, shaft                      |
| 71     | Stand driver                             | 3160   | Driver pedestal                       |        |                                      |
| 73     | Gasket top column                        | 4590.# | Gasket                                |        |                                      |
| 73     | Oring top column (73a)                   | 4610.# | O-ring                                |        |                                      |
| 77     | Tank oil                                 | 3800   | Lubricator                            | 77     | Lubricator                           |
| 79     | Bracket oil tank                         | 3831   | Lubricator bracket                    |        |                                      |
| 83     | Box stuffing                             | 4110   | Stuffing box housing                  | 83     | Box, stuffing                        |
| 85     | Tube enclosing                           | 1917.# | Shaft enclosing tube                  | 85     | Tube, shaft enclosing                |
| 89     | Oring f/oil lube discharge case          | 4610.# | O-ring                                |        |                                      |
| 89     | Seal oil                                 | 4305   | Shaft seal ring                       |        |                                      |

|     |   |        |                                    |     |                                    |
|-----|---|--------|------------------------------------|-----|------------------------------------|
| 99  | Housing bearing threaded lineshaft          | 3240   | Bearing carrier                    |     |                                    |
| 101 | Column pipe                                 | 1350   | Column pipe                        | 101 | Pipe, column                       |
| 103 | Bearing threaded lineshaft                  | 3050.# | Connector bearing                  | 103 | Bearing, line shaft,enclosing      |
| 117 | Bearing sleeve throttle/bushing             | 4132   | Stuffing box bushing               | 63  | Bushing, stuffing box              |
| 125 | Plug pipe grease plug                       | 6578.# | Threaded plug                      |     |                                    |
| 131 | Guard coupling                              | 7450   | Coupling guard                     |     |                                    |
| 171 | Bushing auxiliary throttle                  | 4140   | Auxiliary seal                     |     |                                    |
| 191 | Coupling column threaded                    | 6850   | Pipe coupling                      | 191 | Coupling, column pipe              |
| 301 | Nut enclosing tube                          | 4110   | Stuffing box housing               |     |                                    |
| 301 | Nut packing injection/lube                  | 4110   | Stuffing box housing               |     |                                    |
| 302 | Plate tube tension                          | 1220   | Cover                              | 185 | Plate, tube, tension               |
| 304 | Head discharge                              | 1370   | Discharge head                     | 187 | Head, surface discharge            |
| 304 | Plate surface                               | 1370   | Discharge head                     | 105 | Elbow, discharge                   |
| 305 | Flange top column                           |        |                                    | 189 | Flange, top column                 |
| 306 | Coupling column threaded (duplicate to 191) | 6850   | Pipe coupling                      | 191 | Coupling, column pipe              |
| 307 | Retainer bearing                            | 3250   | Bearing support                    | 193 | Retainer, bearing, open line shaft |
| 308 | Tube enclosing top                          | 1917.# | Shaft enclosing tube               |     |                                    |
| 309 | Case discharge                              | 1140   | Discharge casing                   | 197 | Case, discharge                    |
| 309 | Spool discharge                             | 1140   | Discharge casing                   |     |                                    |
| 310 | Bowl  | 1170.1 | Pump bowl                          | 199 | Bowl, intermediate                 |
| 311 | Collet drive                                | 2484   | Clamping ring impeller bushing     | 84  | Collet, impeller lock              |
| 311 | Collet threaded                             |        |                                    |     |                                    |
| 312 | Ring thrust split coupling                  | 7410   | Coupling ring                      | 86  | Ring, thrust, split                |
| 312 | Ring thrust split coupling clamp (312b)     | 2531   | Split retaining ring               |     |                                    |
| 312 | Ring thrust split impeller                  | 2520   | Loose (shaft) collar shoulder ring | 82  | Ring, thrust, retainer             |
| 313 | Case suction                                | 1130   | Suction casing                     | 203 | Case, suction                      |
| 314 | Spacer flanged                              |        |                                    | 88  | Spacer, coupling                   |
| 315 | Barrel                                      | 1100   | Casing                             | 205 | Barrel or can, suction             |
| 316 | Strainer suction                            | 6531   | Suction strainer                   | 209 | Strainer                           |
| 319 | Ring wear bowl                              | 1500   | Casing wear ring                   | 213 | Ring, bowl                         |
| 320 | Bearing threaded discharge case             | 3050.# | Connector bearing                  | 103 | Bearing, line shaft,enclosing      |
| 321 | Bearing sleeve discharge case               | 3300.# | Bearing, bushing                   | 39  | Bushing, bearing                   |
| 322 | Bearing sleeve bowl                         | 3300.# | Bearing, bushing                   | 39  | Bushing, bearing                   |
| 323 | Bearing sleeve suction                      | 3300.# | Bearing, bushing                   | 39  | Bushing, bearing                   |
| 325 | Screw cap hex/head column to column         | 6570.# | Screw                              |     |                                    |
| 326 | Screw cap hex/head column to head           | 6570.# | Screw                              |     |                                    |
| 326 | Stud threaded column to head                | 6572.# | Stud                               |     |                                    |
| 326 | Stud threaded packing gland                 | 6572.# | Stud                               |     |                                    |

|     |  |        |                             |    |               |
|-----|--|--------|-----------------------------|----|---------------|
| 326 | Stud threaded seal housing                     | 6572.# | Stud                        |    |               |
| 327 | Nut hex column to column                       | 6581.# | Hexagon nut                 |    |               |
| 327 | Nut hex column to head                         | 6581.# | Hexagon nut                 |    |               |
| 327 | Nut hex packing gland                          | 6581.# | Hexagon nut                 |    |               |
| 327 | Nut hex seal housing                           | 6581.# | Hexagon nut                 |    |               |
| 328 | Screw set protective collar                    | 6814.# | Grub screw                  |    |               |
| 328 | Screw set stuffing box sleeve                  | 6814.# | Grub screw                  |    |               |
| 330 | Liner tube stabilizer                          |        |                             |    |               |
| 334 | Screw lock adjusting nut                       | 6570.# | Screw                       |    |               |
| 335 | Key gib  | 6700.# | Key                         |    |               |
| 336 | Stand driver f/m head                          |        |                             |    |               |
| 337 | Plug pipe hex/socket f/discharge case          | 6578.# | Threaded plug               |    |               |
| 340 | Housing packing                                |        |                             |    |               |
| 341 | Valve shut/off f/tank oiler assy.              |        |                             |    |               |
| 342 | Regulator sight feed f/tank oiler assy.        |        |                             |    |               |
| 343 | Elbow vent f/enclosing tube nut                |        |                             |    |               |
| 344 | Lubrication line w/fittings f/tank oiler assy. |        |                             |    |               |
| 345 | Grease zerk stuffing box                       | 3853   | Grease nipple               |    |               |
| 346 | Slinger  | 2540   | Oil flinger / oil deflector | 40 | Deflector     |
| 347 | Oring stuffing box/throttle bush. Hsg.         | 4610.# | O-ring                      |    |               |
| 348 | Housing throttle/bushing                       | 4210   | Mechanical seal housing     | 83 | Box, stuffing |
| 349 | Housing seal                                   | 4212   | Seal plate                  | 83 | Box, stuffing |
| 350 | Stabilizer tube                                |        |                             |    |               |
| 351 | Screw cap hex/head driver adapter              | 6570.# | Screw                       |    |               |
| 352 | Screw cap hex/head driver stand                | 6570.# | Screw                       |    |               |
| 353 | Nut hex driver stand                           | 6581.# | Hexagon nut                 |    |               |
| 354 | Stud threaded throttle bushing housing         | 6572.# | Stud                        |    |               |
| 355 | Nut hex throttle bushing housing               | 6581.# | Hexagon nut                 |    |               |
| 356 | Screw cap hex/head bowl to discharge case      | 6570.# | Screw                       |    |               |
| 357 | Nut hex bowl to discharge case                 | 6581.# | Hexagon nut                 |    |               |
| 358 | Screw cap hex/head bowl to bowl                | 6570.# | Screw                       |    |               |
| 359 | Pin lock threaded/bowl                         | 2923.# | Pin                         |    |               |
| 360 | Screw cap hex/head column to discharge case    | 6570.# | Screw                       |    |               |
| 361 | Nut hex column to discharge case               | 6581.# | Hexagon nut                 |    |               |
| 363 | Nut hex flanged coupling                       | 6581.# | Hexagon nut                 |    |               |
| 364 | Screw cap socket/head flanged coupling         | 6579.# | Socket head cap screw       |    |               |
| 366 | Screw set lineshaft sleeve                     | 6814.# | Grub screw                  |    |               |

|     |   |        |                  |  |  |
|-----|---|--------|------------------|--|--|
| 369 | Ring flow                                       |        |                  |  |  |
| 370 | Sleeve stuffing box                             | 2450   | Shaft sleeve     |  |  |
| 371 | Oring stuffing box sleeve                       | 4610.# | O-ring           |  |  |
| 372 | Stud threaded barrel                            | 6572.# | Stud             |  |  |
| 373 | Nut hex barrel                                  | 6581.# | Hexagon nut      |  |  |
| 374 | Oring barrel                                    | 4610.# | O-ring           |  |  |
| 377 | Gasket suction f/adapter column                 | 4590.# | Gasket           |  |  |
| 378 | Gasket discharge                                | 4590.# | Gasket           |  |  |
| 379 | Screw cap hex/head discharge                    | 6570.# | Screw            |  |  |
| 380 | Nut hex discharge                               | 6581.# | Hexagon nut      |  |  |
| 381 | Screw cap hex/head motor                        | 6570.# | Screw            |  |  |
| 382 | Nut hex motor                                   | 6581.# | Hexagon nut      |  |  |
| 383 | Cap lubricator tank                             |        |                  |  |  |
| 384 | Band lubricator tank                            |        |                  |  |  |
| 385 | Bolt stove f/tank oiler assy.                   |        |                  |  |  |
| 386 | Nut hex f/tank oiler assy.                      | 6581.# | Hexagon nut      |  |  |
| 387 | Lubrication line f/tank oiler assy.             | 3840   | Lubrication line |  |  |
| 388 | Fitting compression elbow f/tank oiler assy.    |        |                  |  |  |
| 389 | Fitting compression straight f/tank oiler assy. |        |                  |  |  |
| 390 | Bearing assembly (ag)                           |        |                  |  |  |
| 392 | Nipple pipe pre-lube                            |        |                  |  |  |
| 393 | Valve gate pre-lube                             |        |                  |  |  |
| 394 | Pin lifting f/head                              | 2923.# | Pin              |  |  |
| 395 | Ring retaining f/head                           |        |                  |  |  |
| 396 | Clip safety f/tube nut                          |        |                  |  |  |
| 397 | Screw cap hex/head tube nut                     | 6570.# | Screw            |  |  |
| 399 | Adapter column flanged to flanged               | 1140   | Discharge casing |  |  |
| 400 | Screw cap hex/head adapter column               | 6570.# | Screw            |  |  |
| 401 | Nut hex adapter column                          | 6581.# | Hexagon nut      |  |  |
| 402 | Bearing rubber cutless discharge case           | 3300.# | Bearing, bushing |  |  |
| 403 | Adapter column flanged to threaded              | 1140   | Discharge casing |  |  |
| 405 | Oring ingerseal                                 | 4610.# | O-ring           |  |  |
| 409 | Adapter driver f/m head                         |        |                  |  |  |
| 412 | Stud threaded base plate                        | 6572.# | Stud             |  |  |
| 413 | Nut hex base plate                              | 6581.# | Hexagon nut      |  |  |
| 414 | Plug pipe head pre-lube                         | 6578.# | Threaded plug    |  |  |
| 415 | Plug pipe head inspection hole                  | 6578.# | Threaded plug    |  |  |
| 416 | Plug pipe head pressure tap                     | 6578.# | Threaded plug    |  |  |
| 417 | Screw cap hex/head coupling guard               | 6570.# | Screw            |  |  |

|     |  |        |                       |  |  |
|-----|--|--------|-----------------------|--|--|
| 418 | Washer flat coupling guard             |        |                       |  |  |
| 419 | Plug pipe stuffing box relief line     | 6578.# | Threaded plug         |  |  |
| 420 | Washer flat column                     |        |                       |  |  |
| 421 | Clip strainer                          |        |                       |  |  |
| 422 | Screw cap hex/head strainer            | 6570.# | Screw                 |  |  |
| 422 | Screw mach submersible strainer        | 6570.# | Screw                 |  |  |
| 424 | Plate serial                           |        |                       |  |  |
| 425 | Screw drive                            | 6570.# | Screw                 |  |  |
| 426 | Jackscrew bowl to bowl                 | 6575.# | Jack screw            |  |  |
| 427 | Jackscrew discharge case to column     | 6575.# | Jack screw            |  |  |
| 428 | Pin impeller wear ring                 | 2923.# | Pin                   |  |  |
| 429 | Pin bowl wear ring                     | 2923.# | Pin                   |  |  |
| 430 | Oring bowl                             | 4610.# | O-ring                |  |  |
| 431 | Oring column                           | 4610.# | O-ring                |  |  |
| 432 | Oring f/oil lube discharge case        | 4610.# | O-ring                |  |  |
| 433 | Key keyed/coupling                     | 6700.# | Key                   |  |  |
| 434 | Ring retaining keyed/coupling          | 2530   | Retaining ring        |  |  |
| 435 | Stud thrust keyed/coupling             | 6572.# | Stud                  |  |  |
| 436 | Oring reinforcing tube to suction case | 4610.# | O-ring                |  |  |
| 437 | Tube reinforcing                       |        |                       |  |  |
| 438 | Oring reinforcing tube                 | 4610.# | O-ring                |  |  |
| 439 | Ring reinforcing                       |        |                       |  |  |
| 440 | Oring top injection tube to housing    | 4610.# | O-ring                |  |  |
| 441 | Coupling column threaded f/suction     | 6850   | Pipe coupling         |  |  |
| 442 | Housing bearing stand                  |        |                       |  |  |
| 443 | Retainer oil                           |        |                       |  |  |
| 444 | Bearing ball                           | 3010   | Anti-friction bearing |  |  |
| 445 | Spacer bearing                         |        |                       |  |  |
| 446 | Bearing ball top                       |        |                       |  |  |
| 447 | Stem bearing                           |        |                       |  |  |
| 448 | Pin non-reverse f/4b-100 & 100         |        |                       |  |  |
| 449 | Spring compression f/4b-100            |        |                       |  |  |
| 450 | Cap bearing stem                       |        |                       |  |  |
| 451 | Plate lube instructions                |        |                       |  |  |
| 452 | Screw drive lube instruction plate     | 6570.# | Screw                 |  |  |
| 453 | Nipple pipe level indicator            |        |                       |  |  |
| 454 | Tee pipe level indicator               |        |                       |  |  |
| 455 | Plug pipe level indicator              | 6578.# | Threaded plug         |  |  |
| 456 | Gauge oil level                        |        |                       |  |  |
| 457 | Cap pipe level indicator               |        |                       |  |  |

|     |  |           |                                  |       |  |
|-----|--|-----------|----------------------------------|-------|--|
| 458 | Guard bearing stand                                    |           |                                  |       |  |
| 459 | Sleeve seal  | 2445      | Shaft sleeve                     |       |  |
| 460 | Seal mechanical  | 4200      | Mechanical seal                  | 65/80 | Seal, mech. Stationary/<br>rotating elements |
| 461 | Collar drive   |           |                                  |       |  |
| 462 | Guard cable f/submersible                              | 8361      | Cable guard                      |       |  |
| 463 | Plug upthrust (submersible)                            |           |                                  |       |  |
| 464 | Screw set upthrust plug                                | 6814.#    | Grub screw                       |       |  |
| 465 | Stud threaded submersible<br>dr. Adapter to suct. Case | 6572.#    | Stud                             |       |  |
| 466 | Nut hex submersible dr.<br>Adapter to suct. Case       | 6581.#    | Hexagon nut                      |       |  |
| 467 | Coupling motor submersible                             | 7010      | Drive coupling                   | 70    | Coupling, shaft                              |
| 468 | Key submersible motor<br>coupling                      | 6700.#    | Key                              |       |  |
| 469 | Jackscrew motor  | 6575.#    | Jack screw                       |       |  |
| 470 | Washer flat tail water strainer                        |           |                                  |       |  |
| 471 | Coupling flanged assembly                              | 7113      | Rigid coupling                   |       |  |
| 472 | Cone diffusion   |           |                                  |       |  |
| 473 | Jackscrew stuffing box                                 | 6575.#    | Jack screw                       |       |  |
| 474 | Clamp coupling guard                                   |           |                                  |       |  |
| 475 | Valve check f/submersible                              | 6301      | Non-return valve                 |       |  |
| 476 | Thrust stand driver/stand                              | 3160      | Driver pedestal                  |       |  |
| 477 | Thrust stand coupling flg<br>flexible                  | 7112      | Flexible coupling                |       |  |
| 478 | Thrust stand cap upper                                 | 3260.2    | Bearing cover                    |       |  |
| 479 | Thrust stand screw cap<br>hex/hd upper/cap             | 6570.#    | Screw                            |       |  |
| 480 | Thrust stand grease zerk cap                           | 3853      | Grease nipple                    |       |  |
| 481 | Thrust stand fitng pipe plug<br>upper/cap              | 6578.#    | Threaded plug                    |       |  |
| 482 | Thrust stand oil/sleeve or<br>thrust/sleeve            | 2470      | Centring sleeve                  |       |  |
| 483 | Thrust stand cap lower                                 | 3260.1    | Bearing cover                    |       |  |
| 484 | Thrust stand screw cap<br>hex/hd lower/cap             | 6570.#    | Screw                            |       |  |
| 485 | Thrust stand fitng pipe plug<br>lower/cap              | 6578.#    | Threaded plug                    |       |  |
| 487 | Thrust stand key driver                                | 6700.#    | Key                              |       |  |
| 488 | Thrust stand key pump shaft                            | 6700.#    | Key                              |       |  |
| 489 | Thrust stand key thrust<br>sleeve                      | 6700.#    | Key                              |       |  |
| 490 | Ring retaining teflon bearings                         |           |                                  |       |  |
| 491 | Bowl w/wr  | 1170.2    | Pump bowl                        | 199   | Bowl, intermediate                           |
| 492 | Impeller w/wr  | 2200      | Impeller                         | 2     | Impeller / propeller                         |
| 493 | Bell suction w/wr & case<br>suction w/wr               | 1310/1130 | Suction bell / suction<br>casing | 55    | Bell, suction                                |
| 494 | Stud threaded bowl to<br>bowl/bell                     | 6572.#    | Stud                             |       |  |
| 495 | Nut hex bowl to bowl/bell                              | 6581.#    | Hexagon nut                      |       |  |
| 496 | Thrust stand vent plug                                 | 6521      | Vent plug                        |       |  |



|     |   |        |                        |  |  |
|-----|---|--------|------------------------|--|--|
| 497 | Thrust stand sight glass                              | 8221   | Sight glass            |  |  |
| 498 | Thrust stand fitng pipe plug                          | 6578.# | Threaded plug          |  |  |
| 499 | Thrust stand fitng pipe plug bush redcr               | 6578.# | Threaded plug          |  |  |
| 500 | Thrust stand bearing housing                          | 3200   | Bearing housing        |  |  |
| 501 | Thrust stand o-ring f/bearing housing                 | 4610.# | O-ring                 |  |  |
| 502 | Thrust stand screw cap hex/hd dr/stand to brg/hsg     | 6570.# | Screw                  |  |  |
| 503 | Thrust stand fitng pipe plug hex/sckt flush seal side | 6578.# | Threaded plug          |  |  |
| 504 | Thrust stand fitng pipe plug hex/sckt flush seal top  | 6578.# | Threaded plug          |  |  |
| 505 | Thrust stand bearing spindle                          | 2471   | Bearing adapter sleeve |  |  |
| 506 | Thrust stand lockwasher                               | 6541   | Lock washer            |  |  |
| 507 | Thrust stand locknut                                  | 6580   | Nut                    |  |  |
| 508 | Thrust stand oil impeller                             | 4223   | Pumping ring           |  |  |
| 509 | Thrust stand o-ring f/bearing housing cap             | 4610.# | O-ring                 |  |  |
| 510 | Thrust stand seal labyrinth                           | 4305   | Shaft seal ring        |  |  |
| 511 | Thrust stand screw cap sockt/hd adjusting nut         | 6579.# | Socket head cap screw  |  |  |



**NOTES:**

**Your Flowserve factory contacts:**

Flowserve Pump Division  
5310 Taneytown Pike, PO Box 91  
Taneytown, MD 21787-0091, USA

Telephone: +1 (410) 756 2602  
Customer Service FAX: +1 (410) 756 2615  
Parts inquiry/Order PH: +1 (800) 526 3569

Flowserve Spain S.L.  
Avenida Fuentemar 26-28  
Coslada, Madrid, Spain 28023

Telephone +34 91 660 4600  
Fax +34 91 674 0433

**Your local Flowserve representative:**

Flowserve Pumps  
Flowserve GB Limited  
PO Box 17, Lowfield Works  
Newark, Notts NG24 3EN  
United Kingdom

Telephone (24 hours) +44 1636 494 600  
Sales & Admin Fax +44 1636 705 991  
Repair & Service Fax +44 1636 494 833  
Email [newarksales@flowserve.com](mailto:newarksales@flowserve.com)

To find your local Flowserve representative please  
use the Sales Support Locator System found at  
[www.flowserve.com](http://www.flowserve.com)

**FLOWSERVE REGIONAL  
SALES OFFICES:**

**USA and Canada**

Flowserve Corporation  
Pump  
5215 North O'Connor Blvd.,  
Suite 2300  
Irving, Texas 75039-5421 USA  
Telephone +1 972 443 6500  
Fax +1 972 443 6800

**Europe, Middle East, Africa**

Flowserve FSG - Italy  
Worthing S.P.A.  
Via Rossini 90/92  
20033 Desio (Milan) Italy  
Telephone +39 0362 6121  
Fax +39 0362 628 882

**Latin America and Caribbean**

Flowserve Corporation  
Pump  
6840 Wynnwood Lane  
Houston, Texas 77008 USA  
Telephone +1 713 803 4434  
Fax +1 713 803 4497

**Asia Pacific**

Flowserve Pte. Ltd  
10 Tuas Loop  
Singapore 637345  
Telephone +65 6771 0600  
Fax +65 6862 2329