

Systempak (Digital/File Type) Millivolt Conversion Module Model J-SMV 90/95

Introduction

The Millivolt Conversion Module converts a DC millivolt input into 1 to 5V DC or 4 to 20 mA.

The J-SMV Module is available for one-output (J-SMV90) or two-output (J-SMV95) model.

The J-SMV provides a linearization function as a standard, which employs up to 101 linearization points to allow a linear output. With the filter function for input and output, the Millivolt Conversion Module can convert signals stably in response to the application.

The range, linearization function, filter function changes, and other such setting changes are easily done with the dedicated Loader Software, which operates on a general-purpose PC. Complete isolation is employed between the power, input, and output circuits. In the two-output model, isolation is also employed between the two output circuits.

Specification

- Input signal: DC millivolt (mV DC)
- Span: ± 100 mV DC rating, $\pm 120\%$ range
- Burnout signal: Upscale or Downscale (Specify when ordering.)
- Burnout response: Within 30 sec
- Output signal:
 - No. 1 output; 1 to 5V DC or 4 to 20 mA DC
 - No. 2 output; 1 to 5V DC (Between No. 1 and No. 2 outputs is isolated.)
 - Edge connector output; 1 to 5V DC (No. 1 output must be 1 to 5V DC when connecting the signal with the A-MC I/O cable.)
- Output impedance:
 - Voltage output; 250 Ω or less, Current output; 250 k Ω or more
- Output range: -20 to +120%FS
- Allowable load resistance: 0 to 600 Ω (Current output: Up to +110%)
- Output update interval:
 - 5 msec (Output hardware filtering 0 to 90% response, 50 msec)
- Input/output response:
 - Minimum of 160 msec, 0 to 90% response (When moving average and 0.1-sec first-order lag filtering are not used)
- Accuracy:

Input span	Both output Nos. 1 and 2
10 mV or more	$\pm 0.15\%$ FS
Less than 10 mV	$\pm 0.15\% \times \frac{\text{Measurement full-scale setting value [mV]} }{\text{Set span width [mV]}}$

- Insulation resistance: 500V DC, 100 M Ω min (Mutual between input - output - GND - power terminal)
- Withstand voltage: 1000V AC, 1 minute (Mutual between input - output - GND - power terminal)
- Power supply: 24V DC $^{+10}_{-15}\%$
- Current consumption: 130 mA or less (at 24V DC)



- Ambient temperature:
 - Normal operating condition; 5 to 45 $^{\circ}$ C
 - Operation limit; 0 to 50 $^{\circ}$ C
- Ambient humidity: 0 to 90%RH (No condensation allowed)
- Mounting: File
- Front mask color: Black
- Weight: 250 g
- Operating influence:
 - Supply voltage effect; $\pm 0.1\%$ FS/24V DC $^{+10}_{-15}\%$
 - Temperature effect;
 - Span 10 mV or more ... $\pm 0.15\%$ FS/10 $^{\circ}$ C
 - Span less than 10 mV ...

$$\pm \frac{0.15 \times \text{Measurement full-scale setting value [mV]} }{\text{Set span width [mV]}} \% \text{FS} / 10^{\circ}\text{C}$$
- Loader settings:
 - Module ID; 16 one-byte characters, 8 two-byte kanji characters
 - Input range; Lo and Hi setting values
 - Linearization table; 101 points
 - Input filtering; Unavailable/available (Moving averaging)
 - Zero-span adjustment; Adjustable between -20 and +120%FS
 - First-order lag filtering; Without/with (0 to 20.0 sec, 63% response time)

Note: Burnout (Upscale, Downscale) is specified by hardware. Please specify it when ordering.
It will be set to Upscale unless otherwise specified.

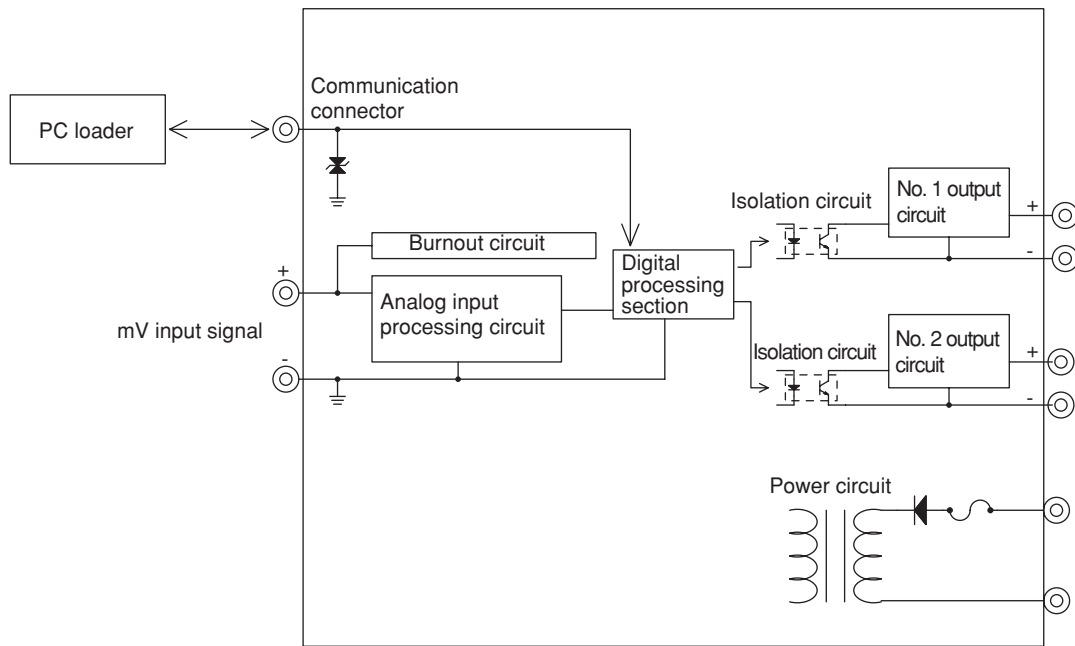

Figure 1. Functional block diagram of millivolt conversion module

Model Number Table

One-output model

Basic Model Number	Selections		Additions	Description
	I	II	I	
J-SMV90				Millivolt conversion module (1-output)
	X			No varnish coated
	C			Varnish coated
		-0		Input mV input
			1	Output 1 to 5V DC
			2	Output 4 to 20 mA DC
			-0	Without test report
			-1	With test report

Two-output model

Basic Model Number	Selections		Additions	Description
	I	II	I	
J-SMV95				Millivolt conversion module (2-output)
	X			No varnish coated
	C			Varnish coated
		-0		Input: mV input
			1	No. 1 output 1 to 5V DC, No. 2 output 1 to 5V DC
			2	No. 1 output 4 to 20 mA DC, No. 2 output 1 to 5V DC
			-0	Without test report
			-1	With test report

Example: J-SMV90-X-01-0

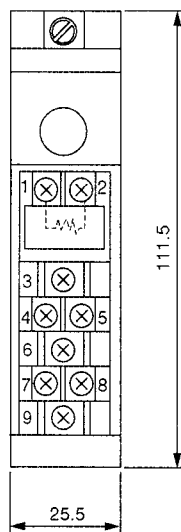
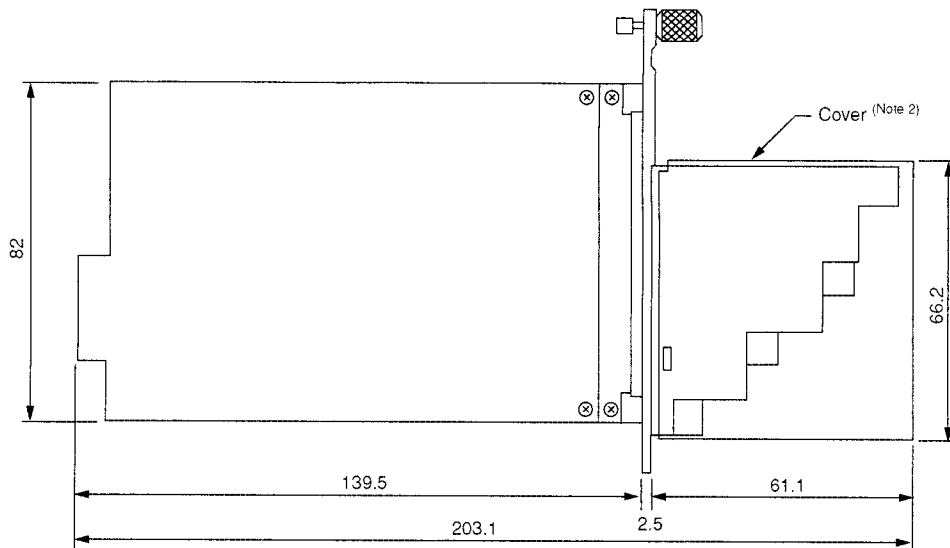

No.	Description
1 (Note 1)	---
2 (Note 1)	Input (-)
3	Input (+)
4	Output 1
5	Output 1
6	Output 2
7	Output 2
8	---
9	GND

- Note 1) 250 Ω resistor is added for current input.
 Note 2) Operate the module with a cover.
 Note 3) Terminal screws: M3.5
 Note 4) Use the pressured terminals with insulation sheath.

Figure 2. Dimensions and wiring diagram

When ordering, please specify:

- 1) Tag number
- 2) Input range* [Set to 0 to 100 mV by default]
- 3) Burnout (Upscale, Downscale) [Set to Upscale by default]

The following are also set by default:

- a) Input filtering: Moving average available
- b) First-order lag filtering: Available, 0.1 sec

* Use the quick list below when specifying the range. Ranges other than those below are also accepted.

Code No.	Input range
01	0 to 5 mV
02	0 to 10 mV
03	0 to 20 mV
04	0 to 50 mV
05	0 to 100 mV

Specifications are subject to change without notice.

azbil

Yamatake Corporation
Advanced Automation Company

1-12-2 Kawana Fujisawa
Kanagawa 251-8522 Japan

URL:<http://www.azbil.com>

This has been printed on recycled paper.

0702-Y/Y