



Thermal

Micro Flow Rate Liquid Flow Meter Model F7M

Thermal Micro Flow Rate
Liquid Flow Meter, achieving
high-functionality measurement
and usability



MODEL SELECTION

Base model No.			Flow rate range				Display function	Flow path material	Piping connection method	Fluid type	Signal type	Connector type	Optional functions 1	Optional functions 2	Optional functions 3	Code	Remarks	
1	2	3	4	5	6	7	8	9	10	11	12	13	14	15	16	17		
F	7	M	9	0	1	0											Measurable flow rate range: 0.1-10 mL/min	
			9	0	3	0											Measurable flow rate range: 0.3-30 mL/min	
							A										No display (equipped with an LED status indicator)	
								Q									Fused quartz glass, PFA, PTFE	
									1								Fitting for fluororesin tubes SUPER-300 Type Pillar fitting P series (made by Nippon Pillar Packing Co., Ltd.) Outer dia. 3 mm, inner dia. 2 mm	
									2								Fitting for fluororesin tubes SUPER-300 Type Pillar fitting P series (made by Nippon Pillar Packing Co., Ltd.) Outer dia. 1/8 in., inner dia. 0.086 in.	
										0							Water (H2O)	
											0						Analog output, digital input, digital output	
												1					Waterproof connector: HR30-6R-6P(71)	
													0				None	
														0			None	
															0		None	
																D	With inspection certificate	
																	0	Product version

PARTS INCLUDED

The following parts are included with the product.

Mounting bracket	× 1
Union nuts	× 2
Sleeves	× 2 (size depends on the model of the main unit)

PARTS SOLD SEPARATELY

Part Name	Part No.	Remarks
PVC-insulated cable, 2 m	F9Y7HP1	Waterproof connector made by Hirose Electric Co., Ltd.; HR30-6R-6P (71)
Fluororesin-insulated cable, 2 m	F9Y7HF1	
Fitting (metric system), 2 sets	F9Y7F1	With sleeves and union nuts (outer dia.: 3 mm; inner dia.: 2 mm); same as included parts
Fitting (inch system), 2 sets	F9Y7F2	With sleeves and union nuts (outer dia.: 1/8 in.; inner dia.: 0.086 in.); same as included parts
Mounting bracket	F9Y7B1	Same as included part
Fluororesin tube assembly (metric system), 2 sets	F9Y7T1	Tube assembly with sleeve inserted (outer dia.: 3 mm; inner dia.: 2 mm; length: 500 mm)
Fluororesin tube assembly (inch system), 2 sets	F9Y7T2	Tube assembly with sleeve inserted (outer dia.: 1/8 in.; inner dia.: 0.086 in.; length: 500 mm)
Fluororesin tube assembly for metal pipes (female screw adaptor), 2 sets	F9Y7T3	Set including an adaptor for metal pipes and a fluororesin tube (outer dia.: 1/8 in., tube length: 200 mm) (adaptor: Rc 1/8 fitting, wetted material SUS316)
Fluororesin tube assembly for metal pipes (male screw adaptor), 2 sets	F9Y7T5	Set including an adaptor for metal pipes and a fluororesin tube (outer dia.: 1/8 in., tube length: 200 mm) (adaptor: R 1/8 fitting, wetted material SUS316)
Adapter for loader communication cable	F9Y7A1	Set including a cable for connecting to power supplier and a cable for flow meter main unit. USB cable for communicating with PC (81441177-00) is not included. SLP-F7M Smart Loader Package for F7M is necessary to download it from the Azbil Corporation's website and install it. http://www.azbil.com/products/factory/factory-product/flowmeter/rate-liquid/f7m/index.html
USB loader cable	81441177-001	USB cable for usage of Adapter for loader communication cable. Use Rev. 05 or later version of the USB loader cable.



Please read "Terms and Conditions" from the following URL before ordering and use.
<http://www.azbil.com/products/factory/order.html>

HART is a registered trademark of HART Communication Foundation. Other product names, model numbers and company names may be trademarks of the respective company.

[Notice] Specifications are subject to change without notice. No part of this publication may be reproduced or duplicated without the prior written permission of Azbil Corporation.

Azbil Corporation
Advanced Automation Company
Yamatake Corporation changed its name to Azbil Corporation on April 1, 2012.
1-12-2 Kawana, Fujisawa
Kanagawa 251-8522 Japan
URL: <http://www.azbil.com>

1st Edition : Dec. 2017-SO
2nd Edition : Jun. 2018-SO

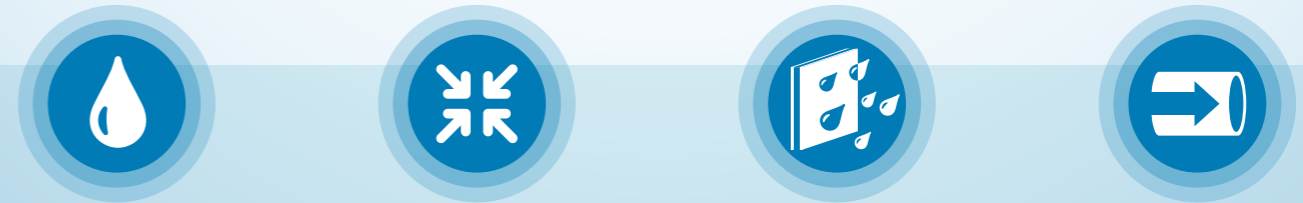

Measures
30 mL/min or
lower

Compact,
light-weight,
and easy to install

Flexible installation
and wide range of
fluids

Straight
flow path

Thermal

Micro Flow Rate Liquid Flow Meter

Model F7M

Features & Merits of the F7M

Combining a thermal MEMS sensor that is commonly used for gas flow meters and a flow path that is made of highly corrosion-resistant fused quartz glass, the product can measure both instantaneous and totalized flow value of micro flow rates **under 30 mL/min**, which is difficult to do with a high degree of reproducibility using traditional measurement methods. Compared with conventional methods, the measurement method used by this new product is **less susceptible to changes in the fluid state (e.g., bubbles, pulsations, and fluid temperature)** (although it may be necessary to change the settings parameters), and **micro flow rates can be measured easily**. Measuring the flow rates allows for **more reliable data management** by replacing alternative measures, such as managing the pump rotation speed, measuring the weight, and managing the fluid supply time. In addition, with the event functions it is possible to detect empty pipes and the presence of bubbles, and to monitor the status of pulsation.



Measures 30 mL/min or lower

Features the thermal measurement principle using MEMS sensing technology. Measuring micro flow rates under 30mL/min, which traditionally has been difficult, is now possible. (Measurement range: 0.1 to 10 mL/min, 0.3 to 30mL/min)

LED indicator

- : Operating normally
- ⚡ : Warning
- ⚡ : Alarm
- : Error

Switch

Used to adjust the zero point when measuring a fluid other than water.

Actual Size

Length: 122 mm
Width: 26 mm
Height: 63 mm



Straight flow path

The straight flow channel means pressure loss is lower and cleaning is easier, with no puddles of liquid.



Compact, light-weight, and easy to install

- This model is more compact and lighter than its predecessors.
- By using the included mounting bracket, it can be easily installed on a surface (for horizontal pipe connection).
- It can also be installed for vertical pipe connection.
- A separate converter (amplifier) is not required.



Flexible installation and wide range of fluids

- Compliant with IP65 protection rating.
- Exterior contains no metal, providing improved resistance to corrosive fluids, allowing use in environments with liquid spray.
- Can be used for a **variety of fluids**, so long as they do not corrode **fused quartz glass** (the material of the flow path) or **fluororesin** (the material of the fitting). The sensor does not come into contact with any fluids.

Product Overview

[Measurable flow rate range] 0.1-10 mL/min or 0.3-30 mL/min

[Measurable fluid] Water (H₂O)

For fluids other than water, the output may shift, depending on its thermal conductivity. Zero-point adjustment and the correction factor setting allow measurements to be taken with a degree of reproducibility that is as high as that for water. (However, accuracy is guaranteed only for water.)

[Pipe connection method] Fluororesin tube (outer dia.: 3 mm; inner dia.: 2 mm or outer dia.: 1/8 in.; inner dia.: 0.086 in.)

Flow Volume Measured: Comparison with Other Methods

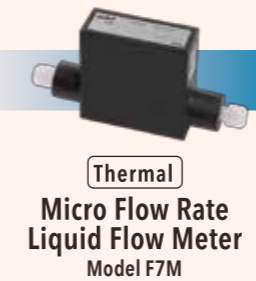
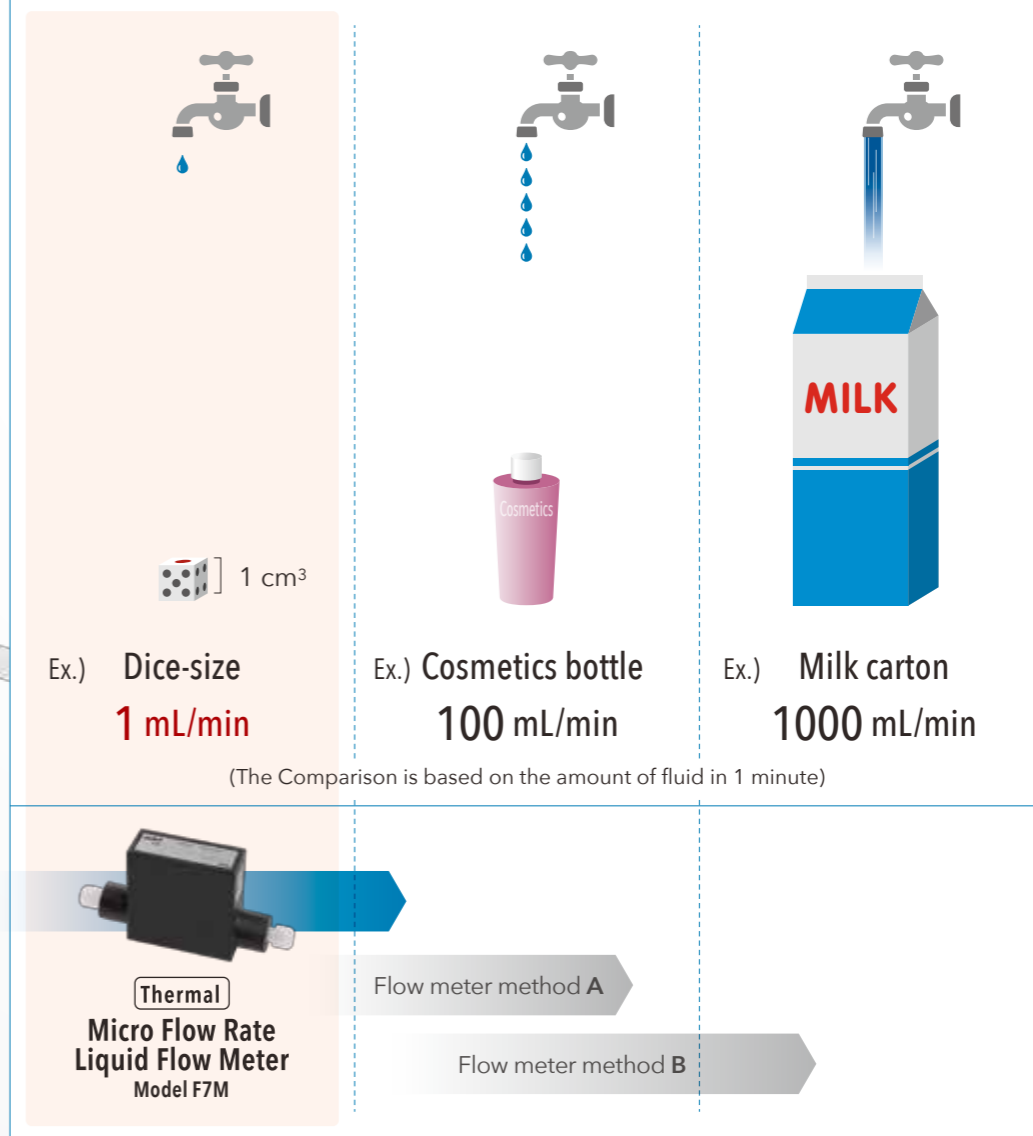

Thermal
Micro Flow Rate
Liquid Flow Meter
Model F7M

Flow meter method A

Flow meter method B

MEASUREMENT PRINCIPLE

Combining a thermal MEMS sensor that is commonly used for gas flow meters and a flow path that is made of highly corrosion-resistant quartz glass, the product uses a method of measuring micro flow rates that is less susceptible to changes in the fluid state and more reliable.

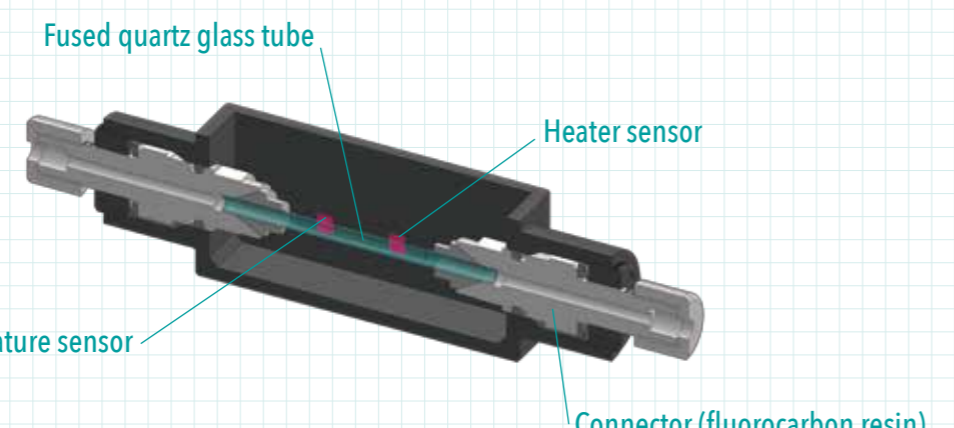

- Heater surface **temperature is constantly controlled to keep it at a fixed value** that is slightly higher than the fluid temperature.
- Heat dissipation from the heater **changes depending on the flow rate**.
- As the flow rate rises, the amount of heat transferred to the fluid increases, and the power consumption of the heater increases.
- By measuring the heater's power consumption, the **flow rate can be calculated**.
(Heat dissipation from the heater is quite small that it does not heat the fluid.)

Output Characteristics Before and After Correction

The measurable range varies according to the thermal conductivity of the fluid, but the output characteristics can be adjusted by using the correction function. (See the conceptual diagrams below.)
For correction factor setting is necessary to use SLP-F7M Smart Loader Package for F7M.

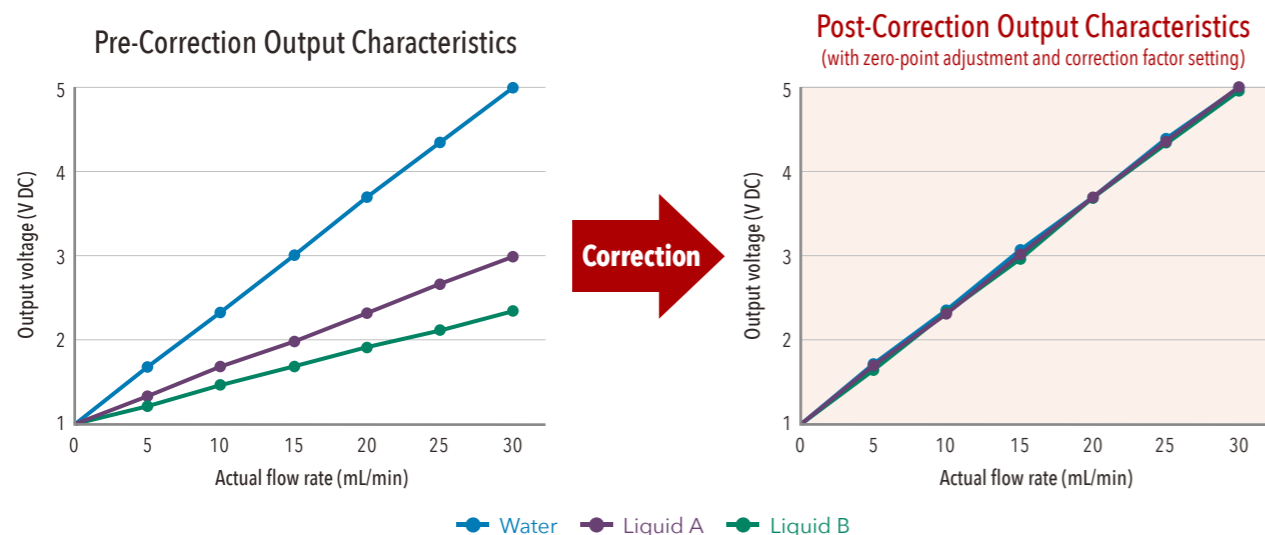

APPLICATION

Filling Ex.) Electrolytic solutions

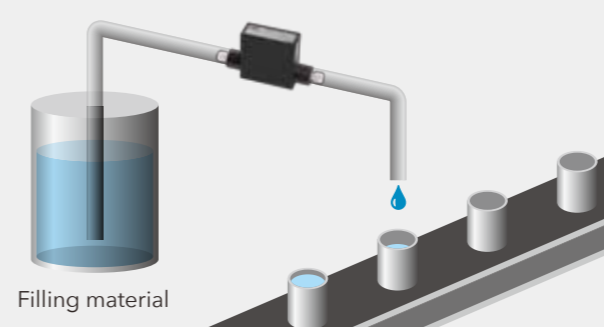

Mixing/Diluting Ex.) Cleaning solutions, chemical agents

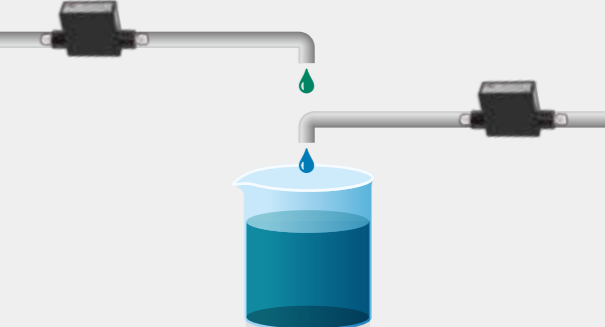

Spraying (1) Ex.) Release agents, steam

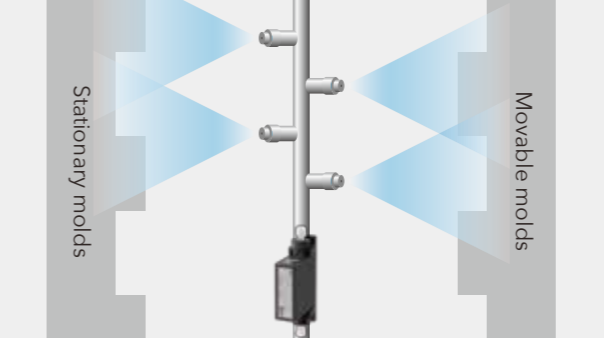

Spraying (2) Ex.) Sterilization solutions, flux

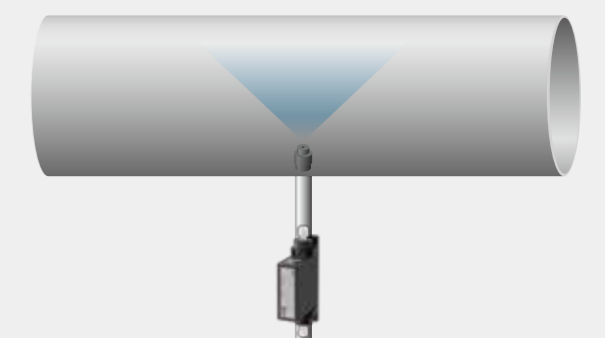

Coating (1) Ex.) Resist solutions, coating agents

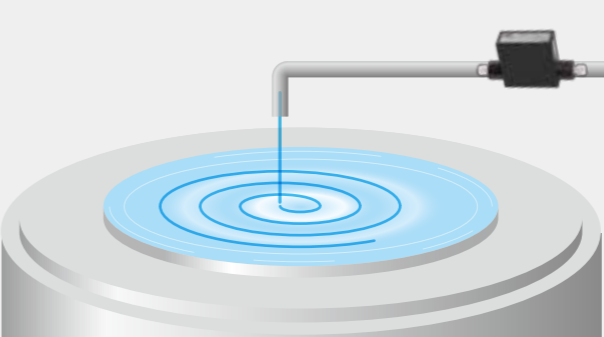

Coating (2) Ex.) Flux, sealants

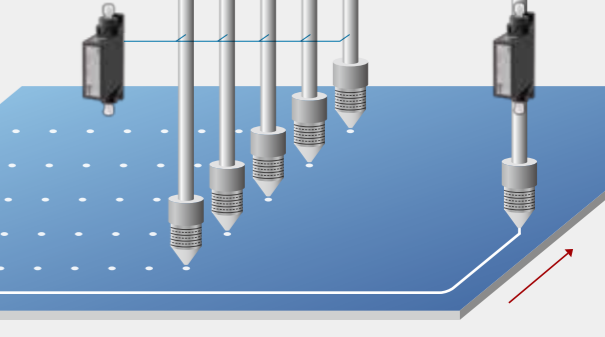

Circulating Ex.) Coolants, lubricants

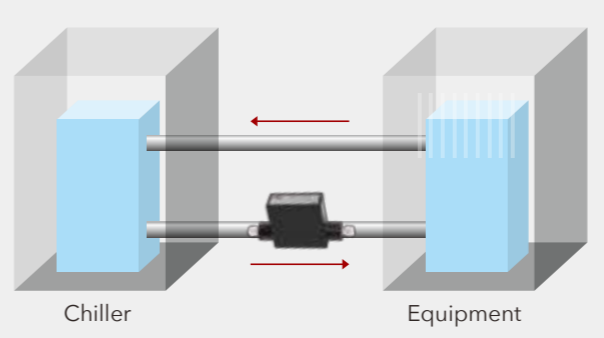

Extracting/Dispensing Ex.) Test reagents, diluted solutions, cleaning solutions

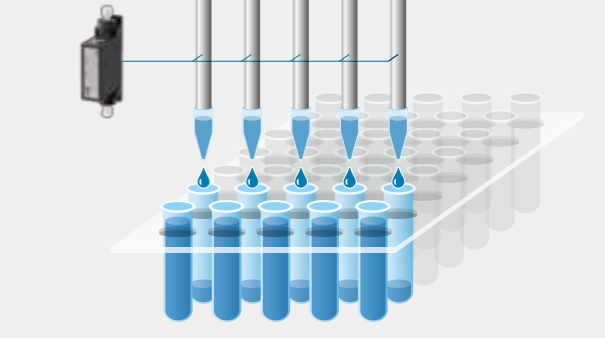

The application drawings above are conceptual images only. When installing this product, see the mounting orientation instructions on page 7.

PRODUCT SPECIFICATIONS

Model No.	F7M9010	F7M9030
Measurable flow rate range (for H ₂ O)	10 mL/min	30 mL/min
Measurable fluid	Fluid that does not clog the flow path or damage the glass tube or corrode the wetted part materials. If any fluid adheres to the inner surface of the flow path, a measurement error may occur. In addition, if there are bubbles in the fluid or pulsation, output fluctuations or shifts may occur, depending on the amount.	
Accuracy-guaranteed fluid	H ₂ O (water)	
Measurement accuracy*1 (typical values under standard conditions)*2	±5 % rdg (at 2 mL/min or more) ±1 % FS (at less than 2 mL/min)	±5 % rdg (at 6 mL/min or more) ±1 % FS (at less than 6 mL/min)
Measurable flow rate range (for H ₂ O)	0.1-11.5 mL/min (1-115 % FS)	0.3-34.5 mL/min (1-115 % FS)
Accuracy-guaranteed flow rate range (for H ₂ O)	0.2-10 mL/min *4 *5	0.6-30 mL/min *4 *5
Reproduceability*3 (typical values under standard conditions)*2	±1 % rdg (at 2 mL/min or more) ±0.2 % FS (at less than 2 mL/min)	±1 % rdg (at 6 mL/min or more) ±0.2 % FS (at less than 6 mL/min)
Response time	1.0 s typ. (63.2 % response)	
Temperature characteristics	±0.5 % rdg/°C when fluid and ambient temperature are in the 10-35 °C range and comparison is with output obtained at fluid temperature of 23 °C while other conditions are identical.	
Fluid pressure range	0 to 500 kPa (gauge)	
Pressure resistance	700 kPa (gauge)	
Mounting orientation	Horizontal or vertical (flow direction: bottom to top) With vertical mounting, an output shift of about ±1 % rdg occurs in measurements compared with horizontal mounting.	
Piping connection method (for applicable tubes)	PFA tube fitting, SUPER-300 series P-type (made by Nippon Pillar Packing Co., Ltd.) Applicable tubes: Metric system products (outer dia.: 3 mm; inner dia.: 2 mm) or inch system products (outer dia.: 1/8 in.; inner dia.: 0.086 in.)	
Operating conditions	Fluid temperature	5-50 °C
	Ambient temperature	5-50 °C
	Ambient humidity	10-90 %RH
	Vibration	None
	Shock (mechanical)	None
Transport and storage conditions	Ambient temperature	5-60 °C
	Ambient humidity	10-90 %RH
	Vibration resistance	4.9 m/s ²
	Shock resistance	490 m/s ² (when packaged)
Required straight pipe length (for H ₂ O)	50 mm straight pipe is required upstream of this device.	
Fitting pullout strength	30N	
Power	Rating: 24 Vdc; allowable power range: 21.6-26.4 Vdc (ripple: 2.5 % or less); power consumption: 0.7 W max.	
Analog output	Output signal	1-5 Vdc
	Maximum output voltage	5.6 Vdc (115 %) (at the upper limit of the measurable flow rate range)
	Required external load resistance	250 kΩ or more
	Output value update cycle	10 ms
	Output resolution	0.01 % max.
Digital output	Number of outputs	1
	Function types	1) Upper/lower limit flow rate event with hysteresis setting function; 2) upper/lower limit flow rate event; 3) totalized flow pulse output; and 4) output event when a problem occurs. (Function allocation settings can be changed using the PC loader.)
	Output ratings	30 Vdc and 30 mA or less (NPN open collector with non-isolated output; contacts open when power is off)
Digital input	Integrating flow pulse	Pulse weight: 0.01, 0.1, 1, and 10 mL/P (pulse width: 5ms typ, 100 Hz max.) (setting can be changed using the PC loader)
	Number of inputs	1, for zero point adjustment only
Digital input	External circuit type	Non-voltage contacts or open collector
	Warm-up time	30 minutes
Protection rating	IP65	
Weight	85 g	
Standards and regulations compliance	EN61326-1, EN61326-2-3	

*1. Instrumental error in the volumetric instantaneous flow rate compared with values obtained with Azbil's standard fluid flow rate equipment as a reference.

*2. Standard conditions are the measurement conditions from (1) to (9) below.

*3. Reproduceability represents an instrumental dispersion in the instantaneous flow rate output under the measurement conditions (1) to (9), with the device remains connected to the piping.

(1) fluid: water (H₂O); (2) fluid temperature: 23 °C; (3) no bubbles or pulsation in the fluid; (4) ambient temperature: 23 °C;
(5) fluid pressure: 250 kPa; (6) vibration: 0 m/s²; (7) stabilization period before measurement : 2 hours or more at ambient temperature 23 °C, 30 minutes or more after power-on, and also 10 minutes or more after supplied flow stabilized.; (8) mounting orientation: horizontal pipe, device top panel facing upward;
(9) output signal : instantaneous flow rate (analog 1 to 5 Vdc);

*4. This device cannot measure the flow rate for a fluid that flows in the reverse direction.

If the flow direction is reversed, the device will output a flow rate that is not equal to the regular forward flow rate without indicating an error.

*5. For a flow rate that is below the minimum measurable range, the output signal is fixed at 0 % (= 1 V).

PARTS AND MATERIAL

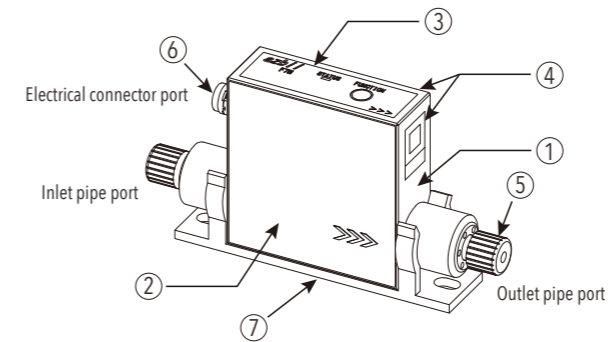

No.	Item	Material	Notes
1	Housing	PPS resin with glass	Epoxy resin adhesive connects the cover to the housing.
2	Cover	PPS resin with glass	
3	Protective sheet	PET resin film	-
4	Label	PET resin film	-
5	Union nut of fitting	PFA	-
6	Waterproof connector	PPS resin, PBT resin, polyacetal resin, chloroprene rubber	HR30-6R-6P (71), made by Hirose Electric Co., Ltd.
7	Mounting bracket	PC resin	-

MATERIAL OF WETTED PARTS

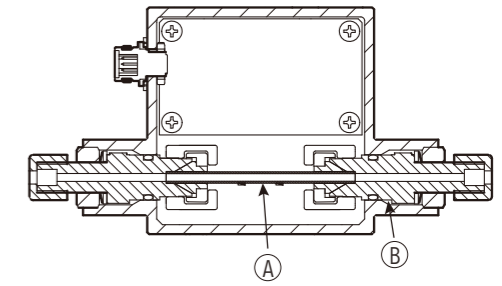

No.	Item	Material	Notes
A	Sensor tube	Fused quartz glass	-
B	Fitting	PFA, PTFE	The material used for the included sleeves is PFA.

MOUNTING ORIENTATION

Install this device in the orientation shown below. The operation panel can face any direction.

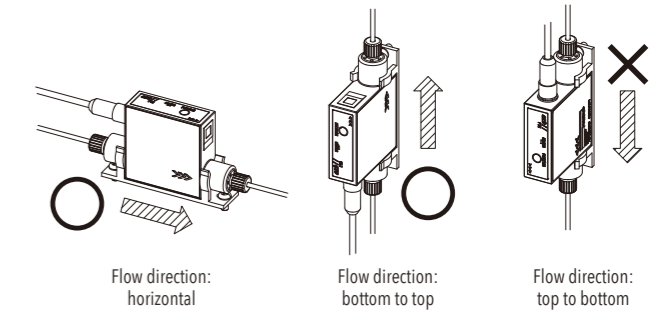

EXTERNAL DIMENSIONS

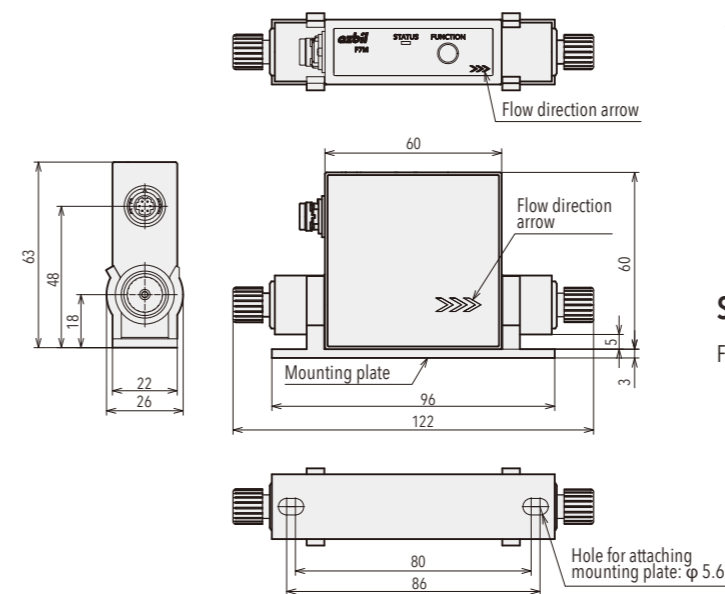

*1. Mounting screws are not included (specification: screw head height of 5 mm max.).

SLP-F7M SMART LOADER PACKAGE FOR F7M

Functions : Setting the parameters, monitoring the flow rate and device status



SELECTION PRECAUTIONS

- Do not apply pressure in excess of the operating conditions described in the specifications or use this device at a temperature outside the specified range. In addition, take care when using this device not to drop it or subject it to vibration or impact in excess of the operating conditions. Otherwise, the quartz glass tube used for the device's fluid path may be damaged or the seal portion of the fluid path may deteriorate, causing the device to leak internally or externally or to malfunction, or causing an external device to catch fire or malfunction.
- Install this device in a place where it will not be subject to vibration. Otherwise, measurements will be incorrect and device malfunction or failure may occur.
- Take appropriate measures to ensure that the fluid is not contaminated with foreign matter. If rust, oil mist, or other foreign matter from the pipes enters and adheres to this device, a measurement error may occur or the device may be damaged. If there is a possibility of foreign matter entering this device, install a filter upstream of the device or take other appropriate measures. Be sure to inspect and replace the filter at regular intervals.
- If malfunction of this device can be expected to result in loss or damage, use appropriate redundancy in the system design.

* In addition to the information provided above, precautions, mounting precautions, and other relevant information can be found in the users' manual (detailed version), document No. CP-SP-1421E. Please refer to this manual also when selecting a model.