



KUNKLE BAILEY 756 SAFETY RELIEF VALVE

The 756 safety valve combines a top piston guided valve and an unobstructed seat bore with a full lift capability, giving maximum discharge capacity



FEATURES

- Design incorporates an adjustable blowdown ring.
- Meets all the requirements of BS6759 Part 1.
- Freely pivoting disc and precision lapped stainless steel trim give positive re-seating for steam duty.
- Fitted with a test lever for inline testing as standard.

GENERAL APPLICATION

The 756 is ideally suited to applications on steam boilers and pipelines where blowdown tolerances are critical.

TECHNICAL DATA

Material: Carbon steel
Sizes: 1" to 3" (DN 25 to 80)
Connections: Flanged
Pressure range: 5 to 348 psig (0.35 to 24 barg)
Temperature range: -20°F to 572°F (-29°C to 300°C)

KUNKLE BAILEY 756 SAFETY RELIEF VALVE

SPECIFICATIONS/DIMENSIONS

SPECIFICATIONS

Materials

Body - Carbon st. gr WCB (-29 to 300°C)
 Trim - Stainless steel

SIZE RANGE

Size, in (DN)	Orifice, mm ²	Min pressure*, barg	Max pressure, barg
1 (25)	415	0.35	24
1¼ (32)	660	0.35	24
1½ (40)	1075	0.35	24
2 (50)	1662	0.35	24
2½ (65)	2827	0.35	24
3 (80)	4301	0.35	24

PERFORMANCE

	BS6759		
	Kdr	Over pressure	Blow down
Steam	0.716	5%	5%*

* or 0.3 barg min

Maximum back pressure

Barg 12
 Constant 0%
 Built-up 50%
 Variable 0%

(Total % must not exceed barg shown)

Connections

Flanged in x flanged out

Cap options

Open lever fitted as standard

Approvals

BS6759 Pt 1
 PED certified category IV

DIMENSIONS

Valve size DN	Inlet *NB	Outlet *NB	A	C Lever	D	Weight (kg)
25	1"	1½"	105	410	100	8.5
32	1¼"	2"	115	455	110	14.0
40	1½"	2½"	140	570	115	20.0
50	2"	3"	150	615	120	30.0
65	2½"	4"	170	725	140	42.5
80	3"	5"	195	825*	160	64.5

Flanged x flanged

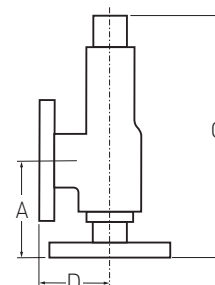

NOTES

* Add 100 mm to the DN 80 Fig. 756 valve only for set pressures above 14 barg.

Flange sizes listed are for:

Carbon steel flanges PN 40x16

Others available on request.

All dimensions in mm

KUNKLE BAILEY 756 SAFETY RELIEF VALVE

PARTS AND MATERIALS

MATERIALS

Item	Part	Carbon steel
1	Body	Carbon steel
2	Bonnet	Carbon steel
3	Cap	Carbon steel
4	Seat	St.St.
5*	Disc	St.St.
7*	Set screw gasket	NAF
8	Blowdown ring	St.St.
9	Setting screw	Brass
10	Guide plate	Bronze
11	Spindle	St.St.
12	Spring plate	Brass
13	Adjusting screw	Brass
14	Locknut	Brass
15	Body stud	Carbon steel
16	Body nut	Carbon steel
17*	Spring	Chrome vanadium
18*	Body/bonnet gasket	NAF
20*	Ball	St.St.
21	Nameplate	St.St.
22	Nameplate pin	Steel
23	Drain plug	Steel
24	Seat pin	St.St.
25*	Split collar	St.St.
26	Adjusting screw bush	PTFE
28	Fulcrum pin	St.St.
29	Spindle nut	Brass
30	Easing lever	Carbon steel
31	Grub screw	St.St.
32	Spindle washer	St.St.
41	Warranty seal	Lead

NOTES

* Recommended spares.
Recommended inspection every 12 months.

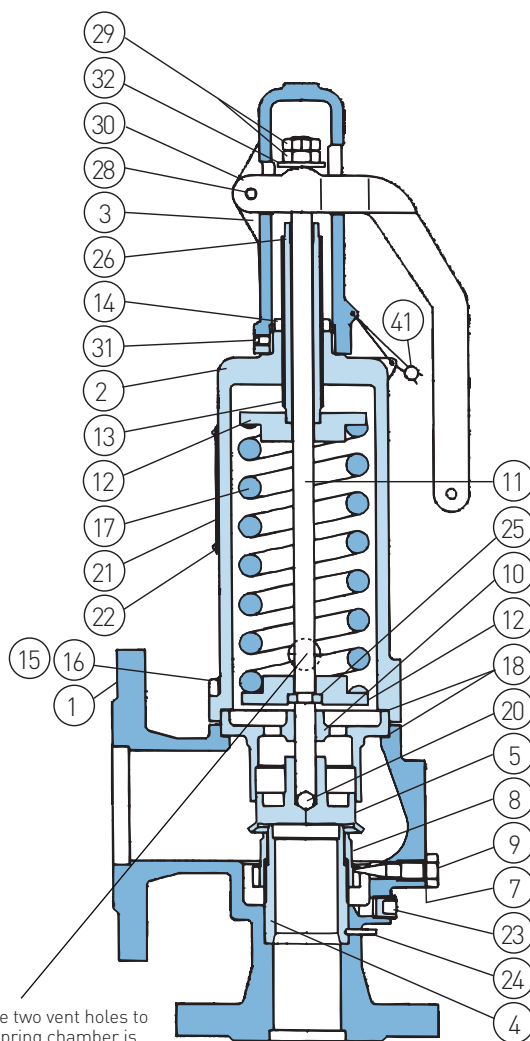

KUNKLE BAILEY 756 SAFETY RELIEF VALVE

STEAM CAPACITY/FSH CONVERSION

SATURATED STEAM CAPACITY (kg/h)

Set pressure (barg)	[BS6759 Pt1 at 5% Overpressure]*					
	DN 25	DN 32	DN 40	DN 50	DN 65	DN 80
0.35	161	257	419	648	1101	1676
1.0	297	472	769	1189	2022	3076
2.0	486	773	1258	1945	3309	5034
3.0	650	1033	1683	2601	4425	6732
4.0	813	1294	2107	3257	5541	8429
5.0	977	1554	2531	3913	6656	10127
6.0	1141	1815	2955	4567	7772	11825
7.0	1305	2075	3380	5225	8888	13522
8.0	1469	2336	3804	5881	10004	15220
9.0	1632	2596	4228	6537	11120	16917
10.0	1796	2857	4653	7193	12235	18615
12.0	2124	3378	5501	8505	14467	22010
12.5	2206	3508	5713	8833	15024	22859
14.0	2451	3898	6350	9817	16699	25405
16.0	2779	4419	7198	11129	18930	28800
18.0	3107	4940	8047	12441	21162	32196
20.0	3434	5461	8896	13753	23393	35591
22.0	3762	5982	9744	15065	25625	38986
24.0	4089	6503	10593	16377	27857	42381

* Minimum overpressure = 0.07 barg at set pressure less than 1.0 barg.

FSH - SUPERHEAT STEAM CORRECTION

Set pressure (barg)	Saturated steam temp. °C	Total steam temperature in degrees centigrade					
		150	200	260	310	370	430
1	120	1.00	0.98	0.93	0.88	0.84	0.80
4	150	1.00	0.99	0.93	0.88	0.84	0.81
7	170	1.00	0.99	0.94	0.89	0.84	0.81
10	361	1.00	0.99	0.94	0.89	0.85	0.81
14	180	1.00	0.99	0.95	0.89	0.85	0.81
18	210	-	1.00	0.95	0.90	0.85	0.81
24	220	-	1.00	0.96	0.90	0.86	0.82
34	240	-	1.00	0.96	0.92	0.86	0.82
41	250	-	1.00	0.97	0.92	0.87	0.82

Other temperatures

This steam table is based on saturated steam, at the temperatures shown.

For steam systems operating at higher temperatures, the above capacities will need to be derated by using the super heat correction factor.

Useful conversions

lbs/h = kg/h x 2.2046

KUNKLE BAILEY 756 SAFETY RELIEF VALVE

SPRING SELECTION

The valves are fitted with a suitable spring. Every valve is tested thoroughly for efficient operation before leaving the factory. Ensure the set pressure is within the range of the existing spring. If not, select and fit the correct spring from the table below. All our springs are low stressed and painted to minimize corrosion.

KUNKLE BAILEY 756 SAFETY RELIEF VALVE

SELECTION GUIDE

Example:	756	1	3	2	2	M
Model						
756						
Type						
1	Conventional					
Size						
1	DN 25 x 40					
2	DN 32 x 50					
3	DN 40 x 65					
4	DN 50 x 80					
5	DN 65 x 100					
6	DN 80 x 125					
Connections						
1	PN 16 RF x PN 16 RF					
2	PN 40 RF x PN 16 RF					
5	ANSI 150 RF x 150 RF					
6	ANSI 300 RF x 150 RF					
Body material						
2	Carbon steel					
Features						
G	Gag					
M	Open lever					

NOTE

- Any special requirements will be indicated by the letter X which will be agreed with the sales office. For example, paint specification or spring material.