



Installation, Operation, and Maintenance Instructions

TYPE 380/390 Series Large Flow Capacity Stainless Steel Air Filter Regulator & Regulator

INTRODUCTION

The Type-380/390 Large Flow Capacity Stainless Steel Filter Regulator & Regulator Series are designed for air or gas service. Maximum allowable inlet pressure is 290 psi (20 BAR). Operating temperatures are -40° to 200°F (-40° to +93°C). The Type-380/390 is able to deliver up to 425 scfm (12,000 nL/min) for rapid actuator stroking. To avoid exceeding outlet pressure limits in service, a pressure-relieving or pressure-limiting device should be provided.

SPECIFICATIONS

	TYPE-380	TYPE-390
Output Ranges	0-30 psig (0-2 BAR), 0-60 psig (0-4 BAR), 0-100 psig (0-7 BAR), 0-150 psig (0-10 BAR), 0-200 psig (0-14 BAR)	
Maximum Supply Pressure	290 psig (20 BAR); Autodrain option: 150 psig (10 BAR)	
Maximum Flow Coefficients (Cv):	3/4" 9.0 1" 10.0	
Filtration	40 micron standard or 5 micron option	Not applicable
Exhaust Capacity	2.0 scfm (56.6 nL/min), downstream pressure 10 psig (0.7 BAR) above set point	
Air Consumption	4 scfh (2 nL/min) maximum	
Operating Temperatures	-40° to +200° F (-40° to +93° C); Autodrain option: 32° to 200°F (0° to 93°C) Low Temperature Option: -62° to 194° F (-52° to 90° C)	
Operating Media	air, inert gas, sweet natural gas	
Porting	Inlet/Outlet: 3/4" NPT or 1" NPT Gauge (2): 1/4" NPT Exhaust: 1/8" NPT	
Materials	316L stainless steel: body, bonnet, filter Nitrile: diaphragm, seals Inconel: valve spring Silicone (Low Temp.): all elastomers	
Weight	3/4" & 1" NPT: 16.6 lbs (7.5 kg)	3/4" & 1" NPT: 14.5 lbs. (6.6 kg)
Mounting	Pipe, bracket or through body direct	

INSTALLATION

1. Install the regulator/filter as close as possible to the instrument or tool it is to service.
2. Clean all pipelines to remove dirt and scale prior to installation.
3. Install the regulator/filter so that the direction of flow is from the "IN" to "OUT" connection as marked on the body of the regulator/filter.
4. For best drainage, orient the drain valve so that it is at the lowest point on the drip well housing.
5. The exhaust port should be kept free and unplugged. Rotating the bonnet relative to the body may change the vent hole orientation.
6. Exhaust may be remotely vented by installing tubing to the 1/8" NPT port. Apply pipe compound or sealing tape to the mail pipe threads prior to installing regulator/filter. Use caution to prevent the sealant from getting inside the regulator/filter.



WARNING: Only qualified personnel should install or service a regulator. Regulators should be installed, operated, and maintained in accordance with international and applicable codes and regulations, and ControlAir instructions. If the regulator vents fluid or a leak develops in the system, it indicates that service is required. Failure to take the regulator out of service immediately may create a hazardous condition. Personal injury, equipment damage, or leakage due to escaping fluid or bursting of pressure-containing parts may result if this regulator is over pressured or is installed where service conditions could exceed the limits given in the Specifications section, or where conditions exceed any rating of the adjacent piping or piping connections. To avoid such injury or damage, provide pressure-relieving or pressure-limiting devices (as required by the appropriate code, regulation, or standard) to prevent service conditions from exceeding limits. Additionally, physical damage to the regulator could result in personal injury and property damage due to escaping fluid. To avoid such injury and damage, install the regulator in a safe location. The internal relief valve in the Type-380 regulators does not provide full overpressure protection. The internal relief valve is designed for minor seat leakage only.

OPERATION

1. Prior to turning on supply air, back off adjusting screw until there is no compression of the range spring.
2. After applying the air supply, outlet pressure will be increased by rotating the adjustment screw clockwise. Pressure can be decreased by turning counter clockwise.
3. Tighten locknut to maintain desired pressure setting.



WARNING: To avoid personal injury resulting from sudden release of pressure, isolate the regulator from all pressure before attempting disassembly.

MAINTENANCE

1. To remove condensate, from the Type-380, slowly open drain valve by turning clockwise and bleed accumulated liquid.



WARNING: To avoid personal injury, property damage, or equipment damage caused by sudden release of pressure or explosion of accumulated gas, do not attempt any maintenance or disassembly without first isolating the regulator from system pressure and relieving all internal pressure from the regulator.

2. To clean filter element (Type-380)
 - a) Shut off supply pressure and relieve all internal pressure.
 - b) Drain condensate from drip well.
 - c) Remove four corner bolts from bottom of unit and remove drip well housing.
 - d) Remove filter retaining screw.
 - e) Remove filter retainer, filter o-ring seals and filter.
 - f) Clean parts and reassemble in reverse order. Torque bolts to 250 in-lbs (28 N-m).
3. To clean/replace pintle assembly
 - a) Follow steps (a) through (d) above.
 - b) Unscrew collar and remove.
 - c) Remove pintle spring. The Type-390 does not contain a filter or collar. The pintle and pintle spring will be accessible upon removal of base.
 - d) Clean or replace parts as required. Apply a high quality lubricant to all cleaned or replaced o-ring seals.
 - e) Reassemble in reverse order and torque bolts to 250 in-lbs (28 N-m).
4. To clean/replace diaphragm assembly
 - a) Back out the adjusting screw until the spring is no longer compressed.
 - b) Remove the four bonnet bolts and separate the bonnet from the body of the regulator. Remove the spring guide and spring.
 - c) Remove the diaphragm assembly, clean or replace it as necessary and reassemble in reverse order. After placing the diaphragm assembly on the body, push down the assembly to make sure that the pintle is seated properly and strokes smoothly.
 - d) Reassemble in reverse order and torque bolts to 250 in-lbs (28 N-m).
5. Repair kits/replacement parts
 - a) Repair kits include all parts marked with an asterisk (*).
 - b) Order kit as described in exploded view below
 - c) Shut off supply air. Back out adjusting screw
 - d) Remove four corner bolts from bottom of the unit and four bolts on top and remove all parts.
 - e) Replace all parts that show excessive wear. Apply a high quality lubricant to all cleaned or replaced o-ring seals.
 - f) Clean all parts and replace in reverse order. Torque bolts to 250 in-lbs (28 N-m).



WARNING: The materials of the Type-380/390 are compatible with natural gas. The user should be warned, however, that the Type-380/390 regulator may vent some gas to the atmosphere. In hazardous or flammable service, vented gas may accumulate and cause personal injury, death, or property damage due to fire or explosion. If regulator is used in a hazardous gas service area, the regulator must be vented to a remote, safe location away from air intakes or any other hazardous area. The vent line or stack opening must be protected against condensation or clogging. Do not use these products where pressure and temperatures can exceed those listed under specifications.

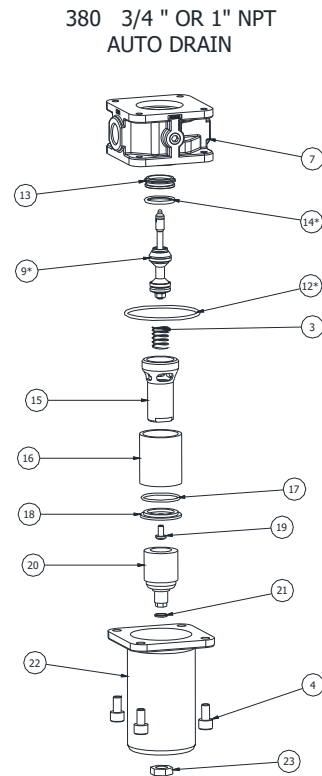
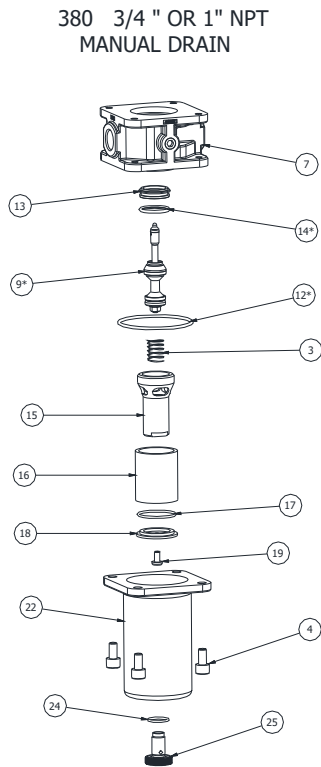
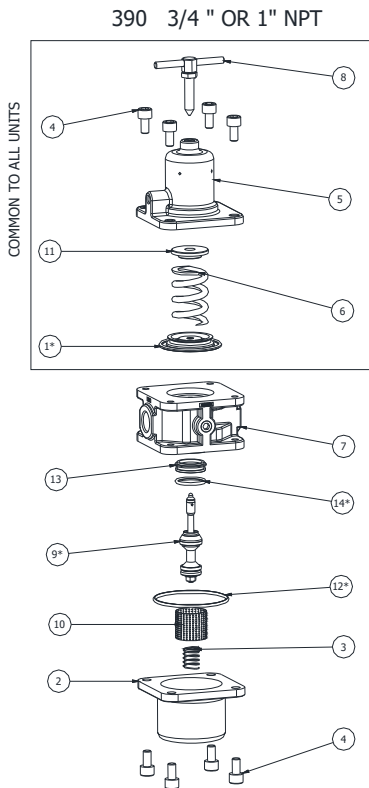

PARTS LIST		
ITEM	QTY	DESCRIPTION
1*	1	DIAPHRAGM ASSEMBLY
2	1	BASE, MACHINED
3	1	SPRING, VALVE
4	8	BOLT, SHCS
5	1	BONNET, MACHINED
6	1	SPRING, RANGE
7	1	BODY ASSEMBLY
8	1	ADJUSTING SCREW ASSEMBLY
9*	1	PINTLE ASSEMBLY
10	1	SCREEN
11	1	SPRING GUIDE, MACHINED
12*	1	O-RING, BOWL SEAL
13	1	SEAT, SUPPLY, MACHINED
14*	1	O-RING, SUPPLY SEAT
15	1	COLLAR, MACHINED
16	1	FILTER, 40 MICRON
17	1	O-RING, FILTER
18	1	O-RING, FILTER
19	1	SCREW, FILTER RETAINER
20	1	AUTO DRAIN VALVE
21	1	O-RING, AUTO DRAIN
22	1	DRIPWELL, MACHINED
23	1	JAM NUT
24	1	O-RING, DRAIN VALVE, MANUAL
25	1	DRAIN VALVE, MANUAL

* INCLUDED IN STANDARD REPAIR KIT

Repair Kits:

- 449-871-133: 380/390 Relieving
- 449-871-170: 380/390 Non-relieving
- 449-871-171: 380/390 Relieving Low Temp.
- 449-871-172: 380/390 Non-relieving Low Temp.

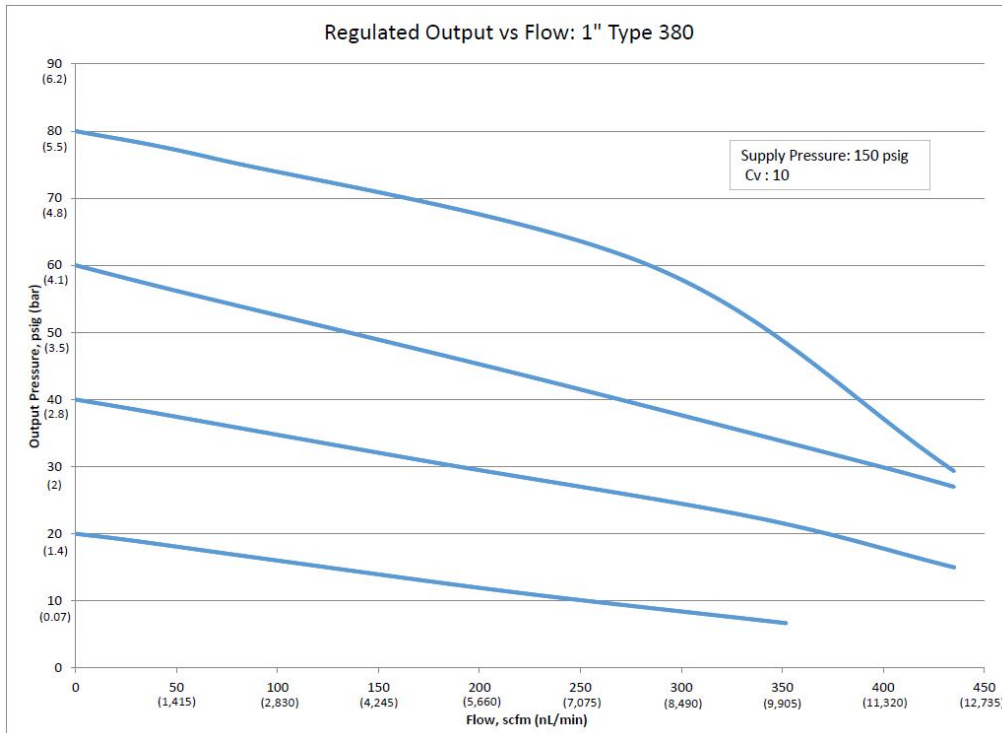
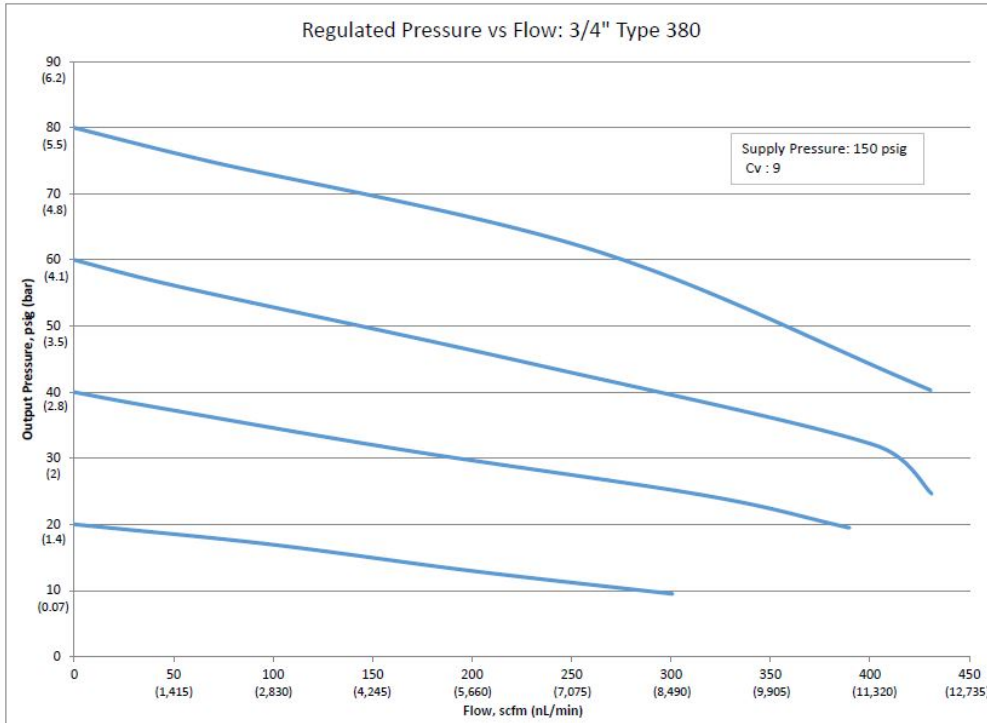

LIMITED WARRANTY & DISCLAIMER

ControlAir LLC products are warranted to be free from defects in materials and workmanship for a period of eighteen months from the date of manufacture, provided said products are used according to ControlAir LLC recommended usages. ControlAir LLC's liability is limited to repair of, refund of purchase price paid for, or replacement in kind of, at ControlAir LLC's sole option, any products proved defective. ControlAir LLC reserves the right to discontinue manufacture of any product or change product materials, design or specifications without notice. Note: ControlAir does not assume responsibility for the selection, use, or maintenance of any product. Responsibility for the proper selection, use, and maintenance of any ControlAir product remains solely with the purchaser and end user.

8 Columbia Drive, Amherst, New Hampshire 03031 U.S.A.

Tel: (603) 886-9400 ♦ Fax: (603) 889-1844

www.controlair.com