

Selection guide

■ SUS model		Example: CMS9500BSRN200000	
Selection		Description	
Basic model No.	CMS ↓ ↓	Gas Mass Flowmeter	
Flow rate range	9500 ○ ○	Air flow rate range 0 to 500mL/min (standard) [Notes 1, 3]	
	0002 ○ ○	Air flow rate range 0 to 2L/min (standard) [Notes 1, 3]	
	0005 ○ ○	Air flow rate range 0 to 5L/min (standard) [Notes 1, 3]	
	0020 ○ ○	Air flow rate range 0 to 20L/min (standard) [Notes 1, 3]	
	0050 ○ ○	Air flow rate range 0 to 50L/min (standard) [Notes 1, 3]	
	0200 ○ ○	Air flow rate range 0 to 200L/min (standard) [Notes 1, 3]	
Display	B ○ ○	Includes display. Flow direction: left → right	
	R ○ ○	Includes display. Flow direction: right → left	
Material	S ○ ○	SUS303 and SUS316	
Connection	R ○ ○	Rc 1/2" (CMS0200/0500)	
		Rc 1/4" (CMS9500/0002/0005/0020/0050)	
Gas type	N ○ ○	Air/nitrogen (changeable to standard gases [Note 3])	
Output	2 ○ ○	4-20mAdc / 0-5Vdc / 1-5Vdc selectable	
	Option (1)	0 ○ ○	(None)
Option (2)	0 ○ ○	(None)	
Option (3)	0 ○ ○	(None)	
Option (4)	1 ○ ○	Gas-contacting parts treated to be oil-inhibited	
	0 ○ ○	(None)	
	D ○ ○	Inspection results provided	
	Y ○ ○	Traceability certificate provided	
Design code	0 ○ ○	Product version	

■ SUS316 model		Example: CMS9500BTTN200000	
Selection		Description	
Basic model No.	CMS ↓ ↓	Gas Mass Flowmeter	
Flow rate range	9500 ○ ○	Air flow rate range 0 to 500mL/min (standard) [Notes 1, 3]	
	0002 ○ ○	Air flow rate range 0 to 2L/min (standard) [Notes 1, 3]	
	0005 ○ ○	Air flow rate range 0 to 5L/min (standard) [Notes 1, 3]	
	0020 ○ ○	Air flow rate range 0 to 20L/min (standard) [Notes 1, 3]	
	0050 ○ ○	Air flow rate range 0 to 50L/min (standard) [Notes 1, 3]	
	0200 ○ ○	Air flow rate range 0 to 200L/min (standard) [Notes 1, 3]	
Display	B ○ ○	Includes display. Flow direction: left → right	
	R ○ ○	Includes display. Flow direction: right → left	
Material	T ○ ○	SUS316	
Connection	U ○ ○	UNF connection: 9/16-18 UNF (CMS9500/0002/0005/0020/0050), 3/4-16 UNF (CMS0200/0500)	
	T ○ ○	Rc 1/4" (CMS9500/0002/0005/0020/0050), Rc 1/2" (CMS0200/0500)	
	S ○ ○	1/4" Swagelok (CMS9500/0002/0005/0020/0050), 1/2" Swagelok (CMS0200/0500)	
	V ○ ○	1/4" VCR (CMS9500/0002/0005/0020/0050), 3/8" VCR or equiv. (CMS0200/0500)	
Gas type	N ○ ○	Air/nitrogen (changeable to standard gases [Note 3])	
Output	S ○ ○	Oxygen [Note 2]	
	E ○ ○	Semi-standards gas: acetylene (C <sub>2</sub> H <sub>2</sub> ), ammonia (NH <sub>3</sub> ) [Note 2]	
Option (1)	2 ○ ○	4-20mAdc / 0-5Vdc / 1-5Vdc selectable	
	0 ○ ○	(None)	
Option (2)	1 ○ ○	RS-485 communications	
Option (3)	0 ○ ○	(None)	
Option (4)	0 ○ ○	(None)	
	1 ○ ○	Gas-contacting parts treated to be oil-inhibited	
	0 ○ ○	(None)	
	D ○ ○	Inspection results provided	
Design code	Y ○ ○	Traceability certificate provided	
	0 ○ ○	Product version	

■ Hydrogen/helium gas model (SUS316)		Example: CMS0010BTTH200100	
Selection		Description	
Basic model No.	CMS ↓ ↓	Gas Mass Flowmeter	
Flow rate range	0010 ○ ○	Air flow rate range 0 to 10L/min (standard) [Note 1]	
	0050 ○ ○	Air flow rate range 0 to 50L/min (standard) [Note 1]	
	0200 ○ ○	Air flow rate range 0 to 200L/min (standard) [Note 1]	
	0500 ○ ○	Air flow rate range 0 to 500L/min (standard) [Note 1]	
	1000 ○ ○	Air flow rate range 0 to 1000L/min (standard) [Note 1]	
	2000 ○ ○	Air flow rate range 0 to 2000L/min (standard) [Note 1]	
Display	B ○ ○	Includes display. Flow direction: left → right	
	R ○ ○	Includes display. Flow direction: right → left	
Material	T ○ ○	SUS316	
Connection	U ○ ○	UNF connection: 9/16-18 UNF (CMS0010/0050/0200), 3/4-16 UNF (CMS0500/1000/2000)	
	T ○ ○	Rc connection: Rc 1/4" (CMS0010/0050/0200), Rc 1/2" (CMS0500/1000/2000)	
	S ○ ○	Swl connection: 1/4" Swagelok (CMS0010/0050/0200), 1/2" Swagelok (CMS0500/1000/2000)	
	V ○ ○	VCR connection: 1/4" VCR (CMS0010/0050/0200), 3/8" VCR or equiv. (CMS0500/1000/2000)	
Gas type	H ○ ○	Hydrogen, helium [Note 5]	
Output	2 ○ ○	4-20mAdc / 0-5Vdc / 1-5Vdc selectable	
	0 ○ ○	(None)	
Option (1)	1 ○ ○	RS-485 communications	
Option (2)	0 ○ ○	(None)	
Option (3)	1 ○ ○	Gas-contacting parts treated to be oil-inhibited	
Option (4)	0 ○ ○	(None)	
	D ○ ○	Inspection results provided	
	Y ○ ○	Traceability certificate provided	
Design code	0 ○ ○	Product version	

• A circle (o) denotes availability.

- Notes
- "Standard" refers to the flow rate after conversion to 20°C, 101.325kPa (1 atmosphere).
  - When oxygen (gas type: S) or Semi-standards gas (gas type: E) are selected, make sure to specify "1: Gas-contacting parts treated to be oil-inhibited" for option (3). Note that resin and hydrogen models cannot be used for oxygen.
  - Gas type is set to air/nitrogen at the factory. The user can change to any of the gas types listed below using the control panel keys. A change in gas type can result in a change in flow rate range. Consequently, when selecting a gas type, make sure to check the maximum measurable flow rate for the gas type in the specifications of the relevant model. Compatible gas types: air/nitrogen, argon, carbon dioxide, city gas 13A (produced from LNG, 88% methane, calorific value of 45MJ or 46MJ), methane (100%), propane (100%), butane (100%). For other gas types, contact Yamatake Corporation.
  - Compatible gas types for resin and aluminum models are air/nitrogen, argon and carbon dioxide only. The user can change to any of these gas types using the control panel keys. A change in gas type can result in a change in flow rate range. Consequently, when selecting a gas type, make sure to check the maximum measurable flow rate for the gas type in the specifications of the relevant model.
  - Gas type is set to hydrogen at the factory. Change to helium with the gas type selection function. The maximum measurable flow rate is the same for hydrogen and helium.

Optional parts (sold separately)

◆ A dedicated harness is required for each CMS flowmeter. Please order the harness when ordering the CMS.

Name	Applicable models	Harness length	Part No.
Harness with special connector	• Without RS-485 communications	2m	81446594-005
		5m	81446594-006
	• With RS-485 communications	2m	81446594-007
		5m	81446594-008
Mounting bracket	• SUS/SUS316 models (CMS9500/0002/0005/0020/0050)	—	81446628-001
	• Hydrogen/helium gas models (CMS0010/0050/0200)	—	81446721-001
	• SUS/SUS316 models (CMS0200)	—	81446721-001
	• Hydrogen/helium gas models (CMS0500/1000)	—	81446856-001

Please read "Terms and Conditions" from the following URL before ordering and use.

<http://www.azbil.com/products/factory/order.html>

Other product names, model numbers and company names may be trademarks of the respective company.

[Notice] Specifications are subject to change without notice. No part of this publication may be reproduced or duplicated without the prior written permission of Azbil Corporation.

Azbil Corporation  
Advanced Automation Company

Yamatake Corporation changed its name to Azbil Corporation on April 1, 2012.

1-12-2 Kawana, Fujisawa  
Kanagawa 251-8522 Japan  
URL: <http://www.azbil.com>

1st Edition : Mar. 2003-MO  
8th Edition: Sep. 2017-AZ

azbil



# Gas Mass Flowmeter

## High Performance and High Rangeability Gas Flow Meters



# High Accuracy and High Reliability Made Possible by $\mu$ F Sensor

## High rangeability with $\pm 3\%$ RD accuracy.

(\*Standard Model only)

The gas mass flowmeter is a mass flowmeter equipped with Azbil's  $\mu$ F(Micro Flow)sensor, which can detect even the slightest gas flows. It combines the superb performance of the  $\mu$ F sensor not available before and Azbil's original rectification mechanism to realize high accuracy, high resolution, and high rangeability, at the cost of a conventional float type flowmeter. Available in a range of functions, the gas mass flowmeter employs a unique method of measuring gas flow rate that is also resistant to changes in temperature and pressure.

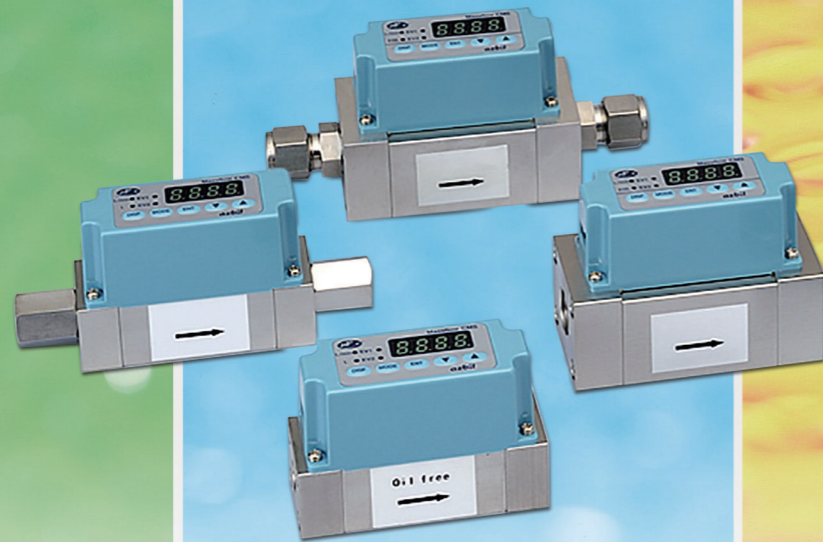

"Standard" indicates the volume flow per minute converted to the conditions of 20°C and 1 atmospheric pressure.

### Structure and features of $\mu$ F (Micro Flow) sensor

- Manufactured by silicon micro-machining and thin-film technologies, this thermal type flow sensor is a mere 1.7mm (squared) and 0.5mm thickness.

- The use of ultra-precision machining technology minimizes variations in element layout and thermal capacity. High resolution of 1 mm/s in flow speed and high-speed response of approx. 2ms are achieved at the sensor chip level.

**[Principle of Measurement]** When gas flow does not exist, the temperature distribution around the heater is symmetric. When the gas starts to flow from Ru to Rd, the temperature at Ru upstream begins to decrease, while the temperature at Rd downstream increases, thus causing a distortion in the symmetry in temperature distribution. This temperature difference between Ru and Rd is used to calculate the mass velocity (velocity x density).

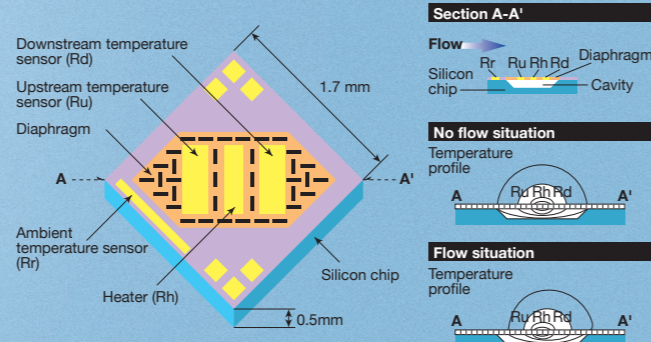

## Solutions to a range of application needs...

### Need: A low cost and high accuracy / resolution mass

The gas mass flowmeter is equipped with a Micro Flow sensor to offer high accuracy of  $\pm 3\%$  RD, repeatability of 0.5% FS and wide rangeability of 100:1, all at low cost.

### Need: Elbow piping on the upstream side

To obtain stable measurement, a conventional flowmeter requires a long straight piping area at the upstream side. The gas mass flowmeter, however, can assure stable measurement without a straight piping area, due to the superior performance of  $\mu$ F sensor and Azbil's rectification mechanism. It can even be connected to an elbow pipe, allowing for easy design of piping layout.

### Need: A mass flowmeter with a variety of functions

The gas mass flowmeter offers a variety of functions, such as instantaneous /integrated flow rate indication, analog output, integrated pulse output, event output (2 points) and analog output scaling function and RS-485 communications.

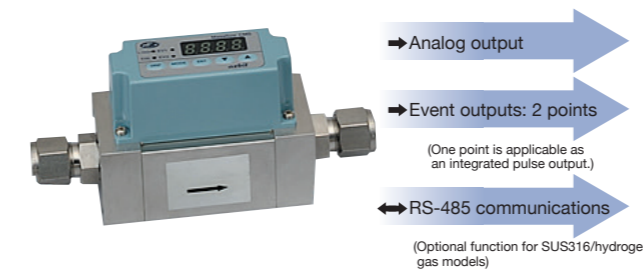

### Need: Low pressure gas measurement

Only 500Pa pressure loss [when the primary pressure is 49kPa for the CMS200] due to a special measurement method on the flow path wall.

### Need: A suitable model

A broad selection of the gas mass flowmeter is available to meet any application and price range. Choose a suitable model according to flow rate range, gas passage material, types of gas measured, etc.

## Specifications

### SUS model

Model No.	CMS9500	CMS0002	CMS0005	CMS0020	CMS0050	CMS0200	CMS0500
Compatible gas types	Air, nitrogen, oxygen (oxygen model only), argon, carbon dioxide, city gas 13A (limited to LNG: 45/46MJ), methane (100%), propane (100%) and butane (100%). Gas must be dry and without corrosive components (chlorine, sulfur, acid, etc.). It must also be clean, without dust or oil mist.						
Air flow range [Note 1]	0 to 500 mL/min(standard)	0 to 2 L/min(standard)	0 to 5 L/min(standard)	0 to 20 L/min(standard)	0 to 50 L/min(standard)	0 to 200 L/min(standard)	0 to 500 L/min(standard)
	"Standard" refers to the flow rate after conversion to 20°C, 101.325kPa (1 atmosphere).						
Max. measured flow rate for each gas (at 1 atm, 20°C) [Note 2]	Air/nitrogen 500 mL/min Oxygen [Note 3] 500 mL/min Argon 500 mL/min Carbon dioxide 250 mL/min City gas 13A [Note 4] 400 mL/min Methane 500 mL/min Propane 140 mL/min Butane 100 mL/min	2 L/min 2 L/min 2 L/min 1 L/min 1.5 L/min 2 L/min 0.5 L/min 0.4 L/min	5 L/min 5 L/min 5 L/min 3.3 L/min 4.5 L/min 5 L/min 1.7 L/min 1.25 L/min	20 L/min 20 L/min 20 L/min 10 L/min 15 L/min 20 L/min 5 L/min 5 L/min	50 L/min 50 L/min 50 L/min 25 L/min 40 L/min 50 L/min 14 L/min 12 L/min	200 L/min 200 L/min 200 L/min 100 L/min 150 L/min 200 L/min 50 L/min 50 L/min	500 L/min 500 L/min 500 L/min 250 L/min 400 L/min 500 L/min 140 L/min 120 L/min
Measurement accuracy at 20°C, 1 atm [Note 5]	5≤x<100mL/min ±1% FS±1digit 100≤x≤500mL/min ±3% RD±1digit	0.02≤x<0.4L/min ±1% FS±1digit 0.4≤x≤2L/min ±3% RD±1digit	0.05≤x<1L/min ±1% FS±1digit 1≤x≤5L/min ±3% RD±1digit	0.2≤x<2L/min ±1% FS±1digit 2≤x≤20L/min ±3% RD±1digit	0.5≤x<5L/min ±1% FS±1digit 5≤x≤50L/min ±3% RD±1digit	2≤x<20L/min ±1% FS±1digit 20≤x≤200L/min ±3% RD±1digit	5≤x<50L/min ±1% FS±1digit 50≤x≤500L/min ±3% RD±1digit
Minimum display	1 mL/min	0.01 L/min	0.01 L/min	0.1 L/min	0.1 L/min	1 L/min	1 L/min
Display resolution	1 mL/min	0.01 L/min	0.01 L/min	0.1 L/min	0.1 L/min	1 L/min	1 L/min
Operating temperature	-10 to +60°C						
Storage temperature	-20 to +70°C						
Operating humidity	10 to 90% RH (no condensation allowed)						
Connection method	Rc 1/4"			Rc 1/2"			
Body material	SUS303 and SUS316						
Case material	Polycarbonate						
Operating pressure	-0.07 to +1.0MPa						
Pressure resistance	1.5MPa						
Mounting position	Horizontal, flow direction: left → right or right → left						
Rated voltage	12 to 24Vdc						
Sampling cycle	100ms-10ms						
Output signal (instantaneous flow rate)	0-5Vdc / 1-5Vdc / 4-20mA, selectable using control panel keys						
Event output	Open collector output: 2 points						
Event functions	Specify from among instantaneous flow rate upper/lower limit, cumulative flow countup, reverse-cumulative flow countdown, totalizer pulse output (event 2 only), flow rate data serial output (event 1).						
External contact input	1 (reserved for reset of cumulative count, no-voltage contact)						
Electrical connection	Harness with special connector (sold separately)						
Display	4-digit 7-segment LED, selectable between instantaneous flow rate and cumulative flow						
Weight	Approx. 800g			Approx. 1400g		Approx. 2000g	

### SUS316 model

Model No.	CMS9500	CMS0002	CMS0005	CMS0020	CMS0050	CMS0200	CMS0500
Compatible gas types	Air, nitrogen, oxygen (oxygen model only), argon, carbon dioxide, city gas 13A (limited to LNG: 45/46MJ), methane (100%), propane (100%) and butane (100%). Gas must be dry and without corrosive components (chlorine, sulfur, acid, etc.). It must also be clean, without dust or oil mist.						
Air flow range [Note 1]	0 to 500 mL/min(standard)	0 to 2 L/min(standard)	0 to 5 L/min(standard)	0 to 20 L/min(standard)	0 to 50 L/min(standard)	0 to 200 L/min(standard)	0 to 500 L/min(standard)
	"Standard" refers to the flow rate after conversion to 20°C, 101.325kPa (1 atmosphere).						
Max. measured flow rate for each gas (at 1 atm, 20°C) [Note 2]	Air/nitrogen 500 mL/min Oxygen [Note 3] 500 mL/min Argon 500 mL/min Carbon dioxide 250 mL/min City gas 13A [Note 4] 400 mL/min Methane 500 mL/min Propane 140 mL/min Butane 100 mL/min	2 L/min 2 L/min 2 L/min 1 L/min 1.5 L/min 2 L/min 0.5 L/min 0.4 L/min	5 L/min 5 L/min 5 L/min 3.3 L/min 4.5 L/min 5 L/min 1.7 L/min 1.25 L/min	20 L/min 20 L/min 20 L/min 10 L/min 15 L/min 20 L/min 5 L/min 5 L/min	50 L/min 50 L/min 50 L/min 25 L/min 40 L/min 50 L/min 14 L/min 12 L/min	200 L/min 200 L/min 200 L/min 100 L/min 150 L/min 200 L/min 50 L/min 50 L/min	500 L/min 500 L/min 500 L/min 250 L/min 400 L/min 500 L/min 140 L/min 120 L/min
Measurement accuracy at 20°C, 1 atm [Note 5]	5≤x<100mL/min ±1% FS±1digit 100≤x≤500mL/min ±3% RD±1digit	0.02≤x<0.4L/min ±1% FS±1digit 0.4≤x≤2L/min ±3% RD±1digit	0.05≤x<1L/min ±1% FS±1digit 1≤x≤5L/min ±3% RD±1digit	0.2≤x<2L/min ±1% FS±1digit 2≤x≤20L/min ±3% RD±1digit	0.5≤x<5L/min ±1% FS±1digit 5≤x≤50L/min ±3% RD±1digit	2≤x<20L/min ±1% FS±1digit 20≤x≤200L/min ±3% RD±1digit	5≤x<50L/min ±1% FS±1digit 50≤x≤500L/min ±3% RD±1digit
Minimum display	1 mL/min	0.01 L/min	0.01 L/min	0.1 L/min	0.1 L/min	1 L/min	1 L/min
Display resolution	1 mL/min	0.01 L/min	0.01 L/min	0.1 L/min	0.1 L/min	1 L/min	1 L/min
Operating temperature	-10 to +60°C						
Storage temperature	-20 to +70°C						
Operating humidity	10 to 90% RH (no condensation allowed)						
Connection method	9/16-18 UNF, Rc 1/4", 1/4" Swagelok, and 1/3" VCR or equiv., selectable by model No.			3/4-16 UNF, Rc 1/2", 1/2" Swagelok, and 3/8" VCR or equiv., selectable by model No.			
Body material	SUS316						
O-ring material	Fluoro rubber: Gas type code (N) (S) EPDM: Gas type code (E) EPDM: Ethylene-Propylene-Diene-Methylene (rubber)						
Case material	Polycarbonate						
Operating pressure	-0.07 to +1.0MPa						
Pressure resistance	1.5MPa						
Mounting position	Horizontal, flow direction: left → right or right → left						
Rated voltage	12 to 24Vdc						
Sampling cycle	100ms-10ms						
Output signal (instantaneous flow rate)	0-5Vdc / 1-5Vdc / 4-20mA, selectable using control panel keys						
Event output	2 open collector outputs						
Event functions	Specify from among instantaneous flow rate upper/lower limit, cumulative flow countup, reverse-cumulative flow countdown, totalizer pulse output (event 2 only), flow rate data serial output (event 1).						
External contact input	1 (reserved for reset of cumulative count, no-voltage contact)						
Electrical connection	Harness with special connector (sold separately)						
Display	4-digit 7-segment LED, selectable between instantaneous flow rate and cumulative flow						
Weight	Approx. 800g			Approx. 1400g		Approx. 2000g	

- Notes
- Flow rate range for air. Using the control panel keys, user can select the desired gas type and can also change the scaling of the analog output.
  - The flowmeter can also be used for some gases not listed in this table by means of the gas type conversion factor function. For details, contact Azbil Corporation.
  - Only models with the catalog listing CMS\_ \_ \_ \_ B\_ \_ S\_ \_ \_ 1\_ \_ \_ are for oxygen use.
  - City gas 13A is based on the gases shown below, which are produced from LNG. If the composition of your 13A is different, contact Azbil Corporation.
  - Accuracy information applies to air/nitrogen or oxygen (oxygen gas model).

Gas type name	Calorific value (MJ)	Methane (%)	Ethane (%)	Propane (%)	Butane (%)
City gas 13A-46MJ	46.04655	88	5.8	4.5	1.7
City gas 13A-45MJ	45.007	88.9	6.8	3.1	1.2

## Specifications

### Hydrogen/helium gas model (SUS316)

Model No.	CMS0010	CMS0050	CMS0200	CMS0500	CMS1000	CMS2000
Compatible gas types	Hydrogen and helium. Gas must be dry and without corrosive components (chlorine, sulfur, acid, etc.). It must also be clean, without dust or oil mist.					
Flow range [Note 1]	0 to 10 L/min(standard)	0 to 50 L/min(standard)	0 to 200 L/min(standard)	0 to 500 L/min(standard)	0 to 1000 L/min(standard)	0 to 2000 L/min(standard)
	"Standard" refers to the flow rate after conversion to 20°C, 101.325kPa (1 atmosphere).					
Max. measured flow rate for each gas (at 1 atm, 20°C) [Note 2]	Hydrogen 10 L/min Helium 10 L/min	50 L/min 50 L/min	200 L/min 200 L/min	500 L/min 500 L/min	1000 L/min 1000 L/min	2000 L/min 2000 L/min
Measurement accuracy at 20°C, 1 atm	0.1≤x<2L/min ±1% FS±1digit 2≤x≤10L/min ±5% RD±1digit	0.5≤x<10L/min ±1% FS±1digit 10≤x≤50L/min ±5% RD±1digit	2≤x<40L/min ±1% FS±1digit 40≤x≤200L/min ±5% RD±1digit	5≤x<100L/min ±1% FS±1digit 100≤x≤500L/min ±5% RD±1digit	10≤x<200L/min ±1% FS±1digit 200≤x≤1000L/min ±5% RD±1digit	20≤x<400L/min ±1% FS±1digit 400≤x≤2000L/min ±5% RD±1digit
Minimum display	0.01 L/min	0.1 L/min	1 L/min	1 L/min	1 L/min	5 L/min
Display resolution	0.01 L/min	0.1 L/min	1 L/min	1 L/min	1 L/min	5 L/min
Operating temperature	-10 to +60°C					
Storage temperature	-20 to +70°C					
Operating humidity	10 to 90% RH (no condensation allowed)					
Connection method	9/16-18 UNF, Rc 1/4", 1/4" Swagelok, and 1/3" VCR or equiv., selectable by model No.			3/4-16 UNF, Rc 1/2", 1/2" Swagelok, and 3/8" VCR or equiv., selectable by model No.		
Body material	SUS316					
Case material	Polycarbonate					
Operating pressure	-0.07 to +1.0MPa					
Pressure resistance	1.5MPa					
Mounting position	Horizontal, flow direction: left → right or right → left					
Rated voltage	12 to 24Vdc					
Sampling cycle	100ms±20ms					
Output signal (instantaneous flow rate)	0-5Vdc / 1-5Vdc / 4-20mA, selectable using control panel keys					
Event output	2 open collector outputs					
Event functions	Instantaneous flow rate upper/lower limit, cumulative flow countup, reverse-cumulative flow countdown, totalizer pulse output (event 2 only), flow rate data serial output (event 1).					
External contact input	1 (reserved for reset of cumulative count, no-voltage contact)					
Electrical connection	Harness with special connector (sold separately)					
Display	4-digit 7-segment LED, selectable between instantaneous flow rate and cumulative flow					
Weight	Approx. 800g			Approx. 1400g		Approx. 2000g

- Notes
- Flow rate range for hydrogen and helium. Using the control panel keys, user can change the scaling of the analog output.
  - The flowmeter can also be used for mixed gases containing hydrogen or helium gases by means of the gas type conversion factor function. For details, contact Azbil Corporation.



CMS9500/0002/0005/0020/0050 (SUS model and SUS316 model)

SUS model

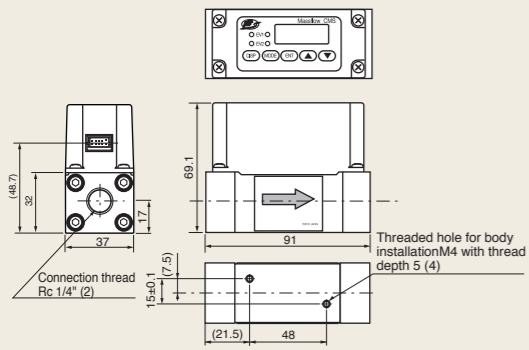

Threaded hole for body installation M4 with thread depth 5 (4)

SUS 316 model

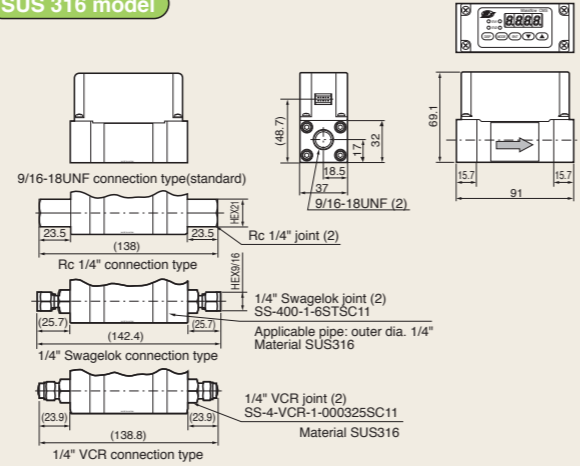

9/16-18UNF connection type (standard)

Rc 1/4" connection type

1/4" Swagelok joint (2)  
SS-400-1-8STSC11

Applicable pipe: outer dia. 1/4"  
Material SUS316

1/4" VCR joint (2)  
SS-4-VCR-1-000325SC11

Material SUS316

CMS0200 (SUS model and SUS316 model)

SUS model

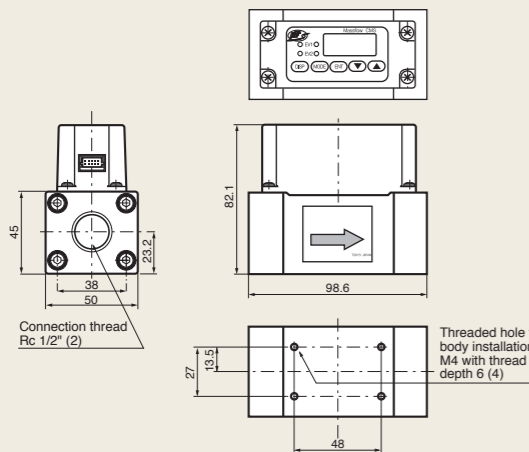

Threaded hole for body installation M4 with thread depth 6 (4)

SUS 316 model

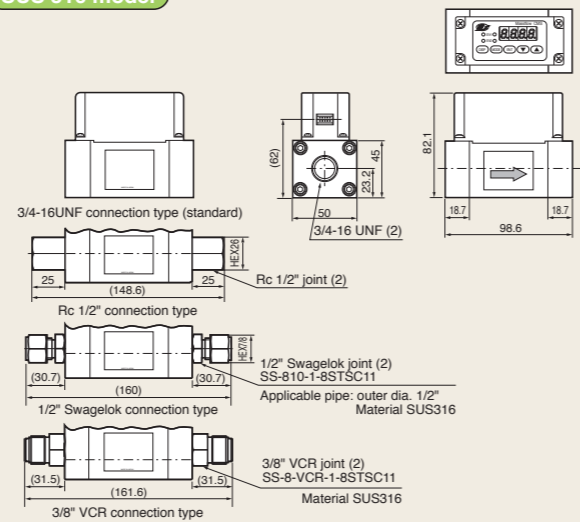

3/4-16UNF connection type (standard)

Rc 1/2" connection type

1/2" Swagelok joint (2)  
SS-810-1-8STSC11

Applicable pipe: outer dia. 1/2"  
Material SUS316

3/8" VCR joint (2)  
SS-8-VCR-1-8STSC11

Material SUS316

CMS0500 (SUS model and SUS316 model)

SUS model

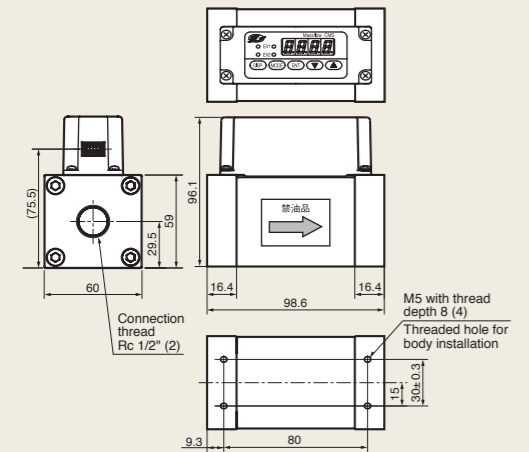

Threaded hole for body installation M5 with thread depth 8 (4)

SUS 316 model

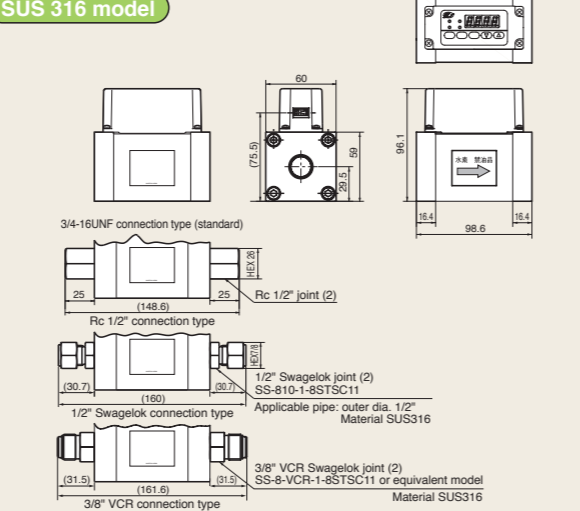

3/4-16UNF connection type (standard)

Rc 1/2" connection type

1/2" Swagelok joint (2)  
SS-810-1-8STSC11

Applicable pipe: outer dia. 1/2"  
Material SUS316

3/8" VCR Swagelok joint (2)  
SS-8-VCR-1-8STSC11 or equivalent model

Material SUS316

CMS0010/0050/0200 (Hydrogen/helium model (SUS316))

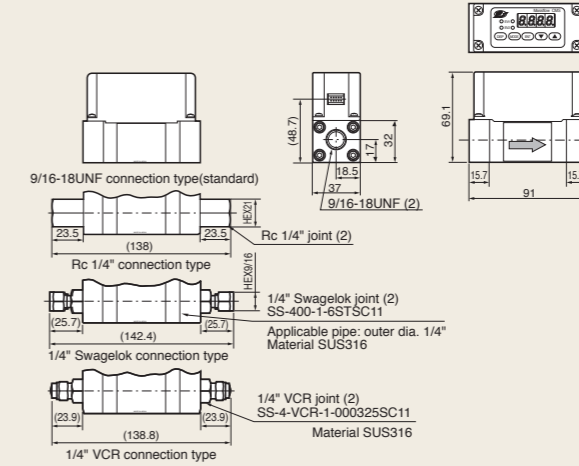

9/16-18UNF connection type (standard)

Rc 1/4" connection type

1/4" Swagelok joint (2)  
SS-400-1-8STSC11

Applicable pipe: outer dia. 1/4"  
Material SUS316

1/4" VCR joint (2)  
SS-4-VCR-1-000325SC11

Material SUS316

CMS0500/1000 (Hydrogen/helium model (SUS316))

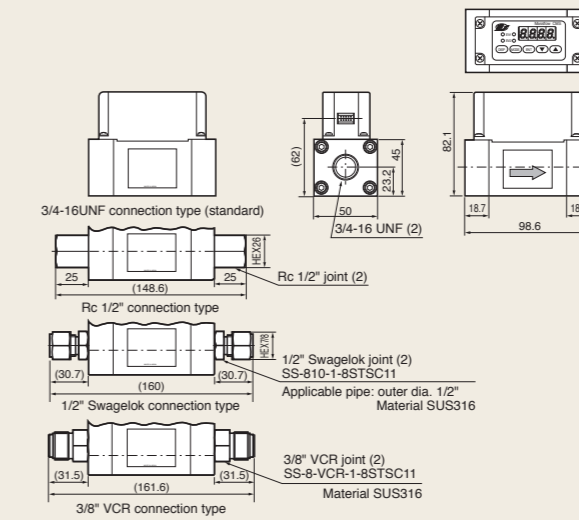

3/4-16UNF connection type (standard)

Rc 1/2" connection type

1/2" Swagelok joint (2)  
SS-810-1-8STSC11

Applicable pipe: outer dia. 1/2"  
Material SUS316

3/8" VCR joint (2)  
SS-8-VCR-1-8STSC11

Material SUS316

CMS2000 (Hydrogen/helium model (SUS316))

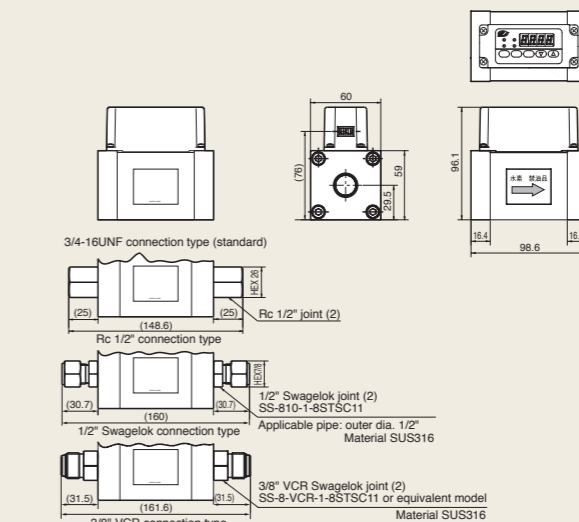

3/4-16UNF connection type (standard)

Rc 1/2" connection type

1/2" Swagelok joint (2)  
SS-810-1-8STSC11

Applicable pipe: outer dia. 1/2"  
Material SUS316

3/8" VCR Swagelok joint (2)  
SS-8-VCR-1-8STSC11 or equivalent model

Material SUS316