



Worcester Controls

17646-L

# Cryogenic Three-Piece Bodied Extended Bonnet Ball Valve

¼" – 2" R6 and R7 C44, ¼" – 2" R6 C4, ½" – 2" R6 C4 V1-V2, and ½" – 2" R7 C44 V1-V2

## Installation, Operation and Maintenance Instructions

**IMPORTANT:** Valves intended for ammonia service must be of stainless (not brass) material, with welded bonnet joint. The standard bonnet joint is brazed, not welded.

**CAUTION:** Flowserve recommends that all products which must be stored prior to installation be stored indoors, in an environment suitable for human occupancy. Do not store product in areas where exposure to: relative humidity above 85%, acid or alkali fumes, radiation above normal background, ultraviolet light, or temperatures above 120°F or below 40°F may occur. Do not store within 50 feet of any source of ozone.

### 1. INSTALLATION:

**CAUTION:** Tighten the packing nut before installing valve, due to creep which occurs after initial assembly.

- A. The Worcester Cryogenic Valve is unidirectional for flow in one direction only and therefore can only be installed in one direction. With the valve in the closed position, install it with the relief hole in the ball on the upstream side. The arrow on the stem top or bonnet will point downstream when the valve is open.
- B. The Worcester Cryogenic Diverter Valve must be installed with the bottom port on the upstream line.

**IMPORTANT:** DO NOT install valves with extended bonnets with the extension tilted more than 30° from the upright vertical position.

The valve is designed to maintain stem seals at normal ambient temperature. Do not insulate the extension fully — allow 3" – 4" of tube to protrude above the insulation.

- C. To install valves with welded, brazed or soldered pipe ends (BW, SW, SWO or TE):

**NOTES:** Prior to welding or brazing, THOROUGHLY CLEAN ALL JOINT SURFACES to prevent contamination.

Worcester brass valves are of leaded forging brass. Brazing cannot be successfully accomplished unless a white flux is used.

1. Tack weld valve in place.
2. Remove three body bolts, loosen fourth, and swing out body with ball open. Close the ball and remove the seats, ball and fluoropolymer coated stainless steel gasket body seals. (Discard the gaskets when removed from the valve.) Note the position of the seats so that they can be replaced in the same position as they were removed.
3. Swing body in and secure it with one additional body bolt diagonally from first.
4. Weld pipe ends. When gas welding, DO NOT play the flame upon the valve body.
5. Allow the valve to cool and then reassemble with ball, seats and new gaskets that are included with the valve.
6. **IMPORTANT:** The fluoropolymer-coated, stainless steel gaskets that are included with the Worcester ¼" – 2" Cryogenic valves make excellent seals, however, some points of caution in their use require emphasizing:
  - a. The gasket body seals are NOT reusable. Upon removal from valve, they should be discarded and replaced with new parts.
  - b. Avoid scratching the fluoropolymer coating of the gaskets during installation. Light lubrication of these seals can help to prevent damage.

- c. "S" type gaskets are installed with their widest flange to the valve body (See view A-A on pages 5 and 6).
- d. Swing center section back in line.
- e. Tighten and torque body bolts evenly and diagonally opposite each other, alternating in a criss-cross pattern. Use torque figures below:

Bolt Diameter	in-lb	ft-lb
1/4"	72 – 94	6 – 8
5/16"	120 – 144	10 – 12
3/8"	192 – 216	16 – 18
7/16"	336 – 384	28 – 32
1/2"	504 – 552	42 – 46

Valve Size	Maximum Expected Breakaway Torque
1/4" – 1/2"	80 in-lb
3/4"	150 in-lb
1"	200 in-lb
1 1/2"	475 in-lb
2"	625 in-lb

## II. OPERATION:

- A. To operate the Worcester Cryogenic Ball Valve turn the stem 1/4 turn clockwise to close and 1/4 turn counterclockwise to open.

On manually operated 1/4" – 2" valves, the handle and the arrow on the top stem flat act as pointers. When they point across the pipeline, the valve is closed. When they point downstream, the valve is open.

- B. To operate the Worcester Cryogenic Diverter Valve, rotate handle 1/4 turn to divert the flow from the bottom port to either of the side ports. The diverter valve comes with a 90° ball and the arrow on the top stem flat can be disregarded. The diverter valve also comes with a special 180° ball. In this case the handle would be rotated 1/2 turn and the handle and the arrow on the top stem flat would point to the port to which flow was diverted.
- C. These valves will provide positive shutoff when used in accordance with the Worcester Cryogenic Valve pressure/temperature chart.
- D. DO NOT leave the ball partly open. DO NOT throttle with Worcester cryogenic valves. It will result in seat breakage.
- E. DO NOT allow media that can solidify, crystallize or polymerize to stand in the valve cavity.
- F. Torque Requirements:

The valve torque will vary depending on the length of time between cycles, line pressure, type of valve seats, and the media in the system.

All figures in the following table are based on laboratory tests with LN2 as the media. These figures should approximate the actual valve torque. For a more detailed analysis of valve torque requirements, see the Worcester Actuator Sizing Manual.

## III. MAINTENANCE:

The Worcester Cryogenic Valve with the extended bonnet normally operates with the bonnet at a higher temperature than the valve. Because of this, there will be a frost line about two-thirds of the way up the extension. If the bonnet should become covered with frost, that would be an indication that the packing rings were leaking.

If stem leakage is noted then adjust retaining nut per following procedure:

**CAUTION: Excessive tightening causes higher torque and shorter stem seal life.**

- A. Packing ring readjustment procedure if possible:
  1. Allow the valve to warm to ambient temperature to allow packing rings to become more flexible.
  2. On Rev. R6 and R7 manual valves, loosen the handle nut to allow easy access to the retaining nut. Loosen top nut on actuated Rev. R6 valves. Rev. 7 actuated valves have a single self-locking stem nut.
  3. For Rev. R6 manual and actuated, and Rev. 7 manual valves, while holding the stem to prevent turning, tighten the retaining or lower nut until Belleville washers are flat (approx. 120 in-lb for 1/4"-1" stems, 130 in-lb for 1 1/2" and 2" stems); then back off 1/8 turn.

For Rev. R7 actuated valves, while holding the stem to prevent turning, tighten the self-locking stem nut until Belleville washers are flat, the nut will "bottom", then back off nut 1/8 turn.

**CAUTION: The self-locking stem nut is difficult to tighten, and must fully flatten Belleville washers before backing off.**

- 4. Retighten the handle nut (Rev. R6 and R7 manual valves) or top nut (R6 actuated valves) while making certain that the retaining or lower nut and stem are immobile.

## IV. REBUILDING:

THIS MANUAL CONTAINS EXPLODED VIEWS OF THE VALVES COVERED BY THE TEXT. THEY HAVE BEEN INCLUDED TO AID IN THE REBUILDING OF VALVES. PLEASE REFER TO THEM WHEN FOLLOWING THE WRITTEN INSTRUCTIONS.

---

### ▲ WARNING: BALL VALVES CAN TRAP PRESSURIZED FLUIDS IN BALL CAVITY WHEN CLOSED

---

If the valve has been used to control hazardous media, it must be decontaminated before disassembly. It is recommended that the following steps be taken for safe removal and disassembly:

- Relieve the line pressure. Operate the valve prior to attempting removal from line.
- Place valve in half-open position and flush the line to remove any hazardous material from valve.
- All persons involved in the removal and disassembly of the valve should wear the proper protective clothing such as face shield, gloves, apron, etc.

A. A standard repair kit can be ordered for the Worcester Cryogenic Valve containing all necessary parts for normal valve rebuilding (all seat springs, and Belleville washers). To order a repair kit you must specify the size, "CRK44", and revision letter ("R" and number). This information will be found in the valve code on the valve body, stop plate, handle, valve nameplate or mounting bracket nameplate. Example: ½" CRK44 R6

If the valve is a non-standard product, then there will be a 5 character suffix in valve code called a "P"-Number, "T"-Number, "C"-Number, or similar found on the valve body, stop plate, handle, valve nameplate, or mounting bracket nameplate. To order repair kit includes size, "CRK44", and "P", "T", "C", or similar number.

**Example:**

½" CRK44 P2577 or ½" CRK44 T0914

---

**CAUTION: If the seats and seals installed differ from those removed, the valve nameplate or stop must be replaced or remarked to indicate the altered materials and ratings, or valve tagged to so indicate.**

---

B. If replacement parts other than those included in the repair kit are needed, order the part by name and size, and include the complete valve code; and for non-standard product add "P", "T", "C", or similar number found on valve body, stop plate, handle, valve nameplate, or mounting bracket nameplate.

**Example:**

Ball; ½" C416 PM SE R6 or  
Ball; ½" C466 PM SE T0914

Porting (if diverter cryogenic valve) must also be specified when ordering these parts:

**Example:**

Ball; 1" C416 PM SE V1 R6

### To Replace the Seats and Rings in ¼" - 2" Cryogenic Valves:

- C. 1. Open valve.
2. Remove three body bolts and loosen fourth to swing the center section out from between pipe ends or remove all four bolts to remove valve from line, whichever is more convenient.
3. Close valve and remove the ball, seats and fluoropolymer coated stainless steel gasket body seals. Discard seats and gaskets.
4. Remove handle nut, lockwasher, handle and stop (if manual valve), retaining nut, Belleville washers, and top packing follower. For Rev. R7 actuated valves remove self-locking stem nut, Belleville washers, and top packing follower.
5.
  - a. Push stem into the body cavity.
  - b. Remove split ring and split thrust bearing from recessed diameter above stem tang.
  - c. Remove stem from top of valve.
  - d. Remove packing ring, bottom packing follower, and thrust bearing(s) from stem.
6. Clean all sealing surfaces of valve including ball.

**NOTE:** The ball and the surfaces against which the seats and seals are installed should be undamaged, clean and free of pit marks and scratches. Light marring from the action of the ball against the seats is normal and will not affect the operation of the valve. Flaws which can be seen but barely detected with fingertips are acceptable. The stem and body surfaces that the thrust bearings and packing ring contact must be undamaged, clean and free from pit marks or scratches.

### To Reassemble:

7.
  - a. Insert stem down through the bonnet and extension into the body cavity.
  - b. Place new split thrust bearing in the recessed diameter above the stem tang. Place new split ring (two pieces) in recessed diameter, under split thrust bearing. Pull stem up so split thrust bearing and split ring are withdrawn into the stem hole recess in the ball cavity. (IMPORTANT: Thoroughly lubricate the split thrust bearing and the split ring with a lubricant compatible with media. White petroleum jelly is a good general purpose lubricant.)
  - c. Install, over extended stem, two new thrust bearings, bottom packing follower, new packing rings (three pieces), and top packing follower. (IMPORTANT: Lightly lubricate thrust bearing packing and follower with a PTFE-based lubricant such as fluorolube S-30 or equivalent, except for valves with V20 or V33 options, which are assembled dry.

**NOTE:** Polyfill thrust bearings (black in color) are now used and included in repair kits. If PEEK thrust bearings (tan in color) were removed, they must be replaced with the Polyfill.

- d. Add two new Belleville washers with outer edges touching and the retaining nut and tighten stem assemblies following procedures in Maintenance, Section III.A.3.  
  
For Rev. R7 actuated valves, add four new Belleville washers, (two pairs of washers with outer edges touching) and self-locking stem nut. Tighten nut following procedures in Maintenance, Section III.A.3.
  - e. Adjust stem so arrow on the top stem flat points downstream when valve is in the open position (hole in ball is upstream when the valve is in the closed position). For Cryogenic-Diverter Valve (90° only) disregard arrow on the top stem flat as stem orientation is not necessary. For Cryogenic-Diverter Valve (180° only) handle and arrow on top stem flat will point to port to which flow is diverted.
  - f. For all manual valves, replace stop, handle, lockwasher and handle nut. For Rev. R6 actuated valves, replace lockwasher and top nut.
8. Place the ball (see note below) in the valve inserting the pin extending from the bottom of the stem tang into the slot machined into the stem slot of the ball. The relief hole in the face of the ball is on the upstream side of the valve, when in the closed position, to insure that cavity relief is upstream.

**NOTE:** For diverter valves, install ball as follows:

**V1 (90° Valves)** – With handle and/or stem flats in line with body main axis, viewed from bolt head side (normally upstream) one ball port is to the right, one is down, and the other is on opposite end of valve.

**V2 (180° Valves)** – Using same convention as V1, one ball port is down and the other is on opposite end of valve.

9. Open ball and install new seats, which have been specially prepared by Flowserve for cryogenic service.
10. Install new gaskets and finish valve assembly per Section I.C., steps 6.a, b, c, d, and e on pages one and two of this manual.
11. Cycle valve several times to ensure displacement of cryogenic lubrication on seats.

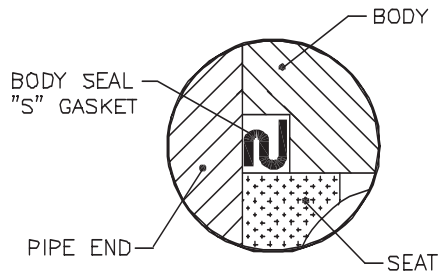

**View A-A**

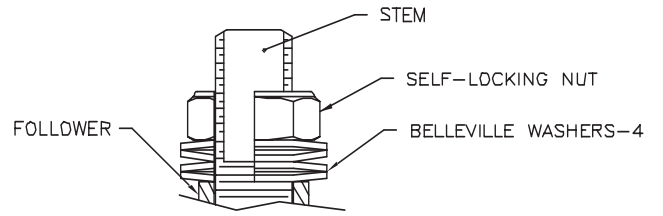

**Automated Valve**

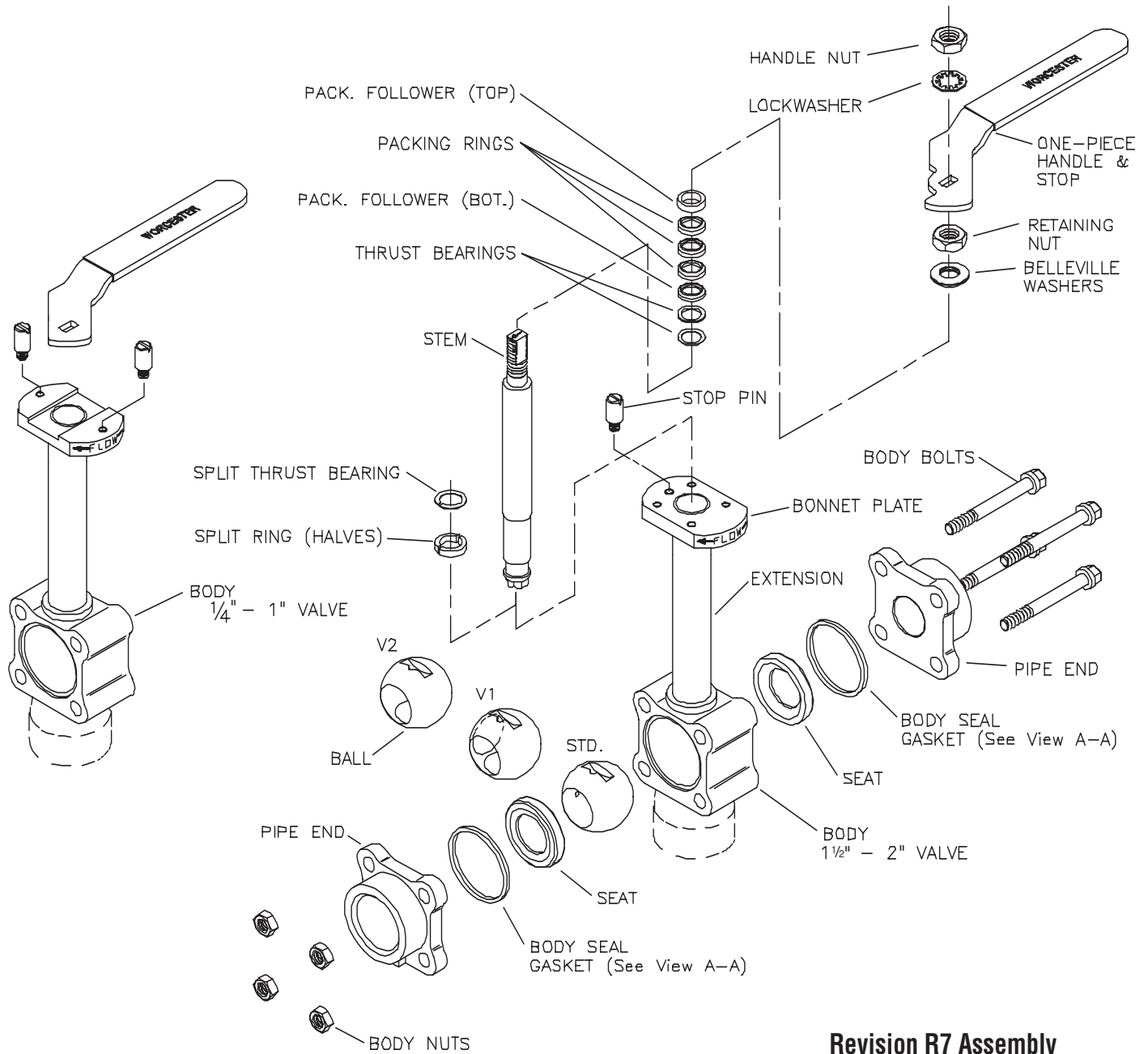

**Revision R7 Assembly**

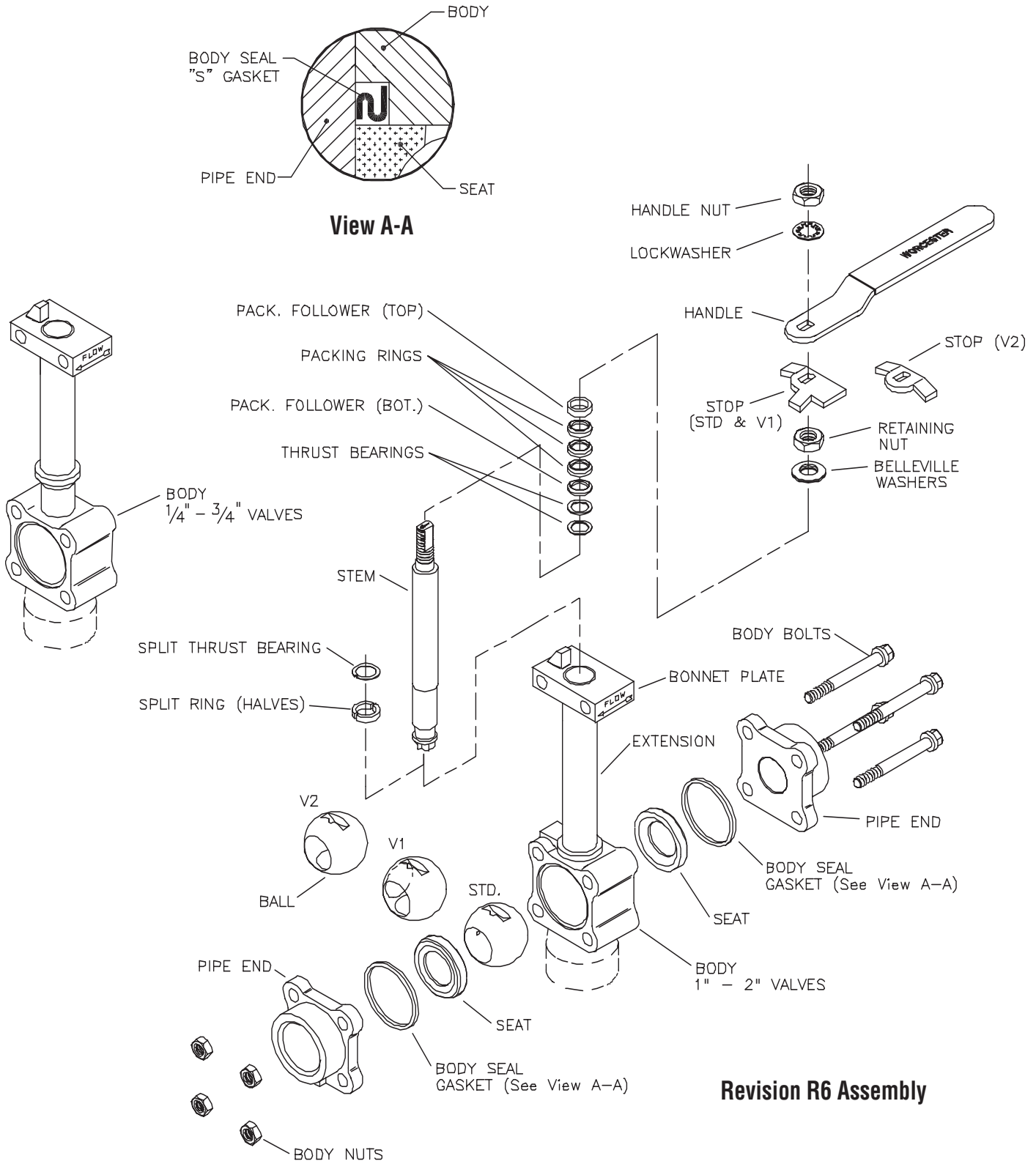

*This page intentionally left blank.*

Flowserve Corporation has established industry leadership in the design and manufacture of its products. When properly selected, this Flowserve product is designed to perform its intended function safely during its useful life. However, the purchaser or user of Flowserve products should be aware that Flowserve products might be used in numerous applications under a wide variety of industrial service conditions. Although Flowserve can (and often does) provide general guidelines, it cannot provide specific data and warnings for all possible applications. The purchaser/user must therefore assume the ultimate responsibility for the proper sizing and selection, installation, operation, and maintenance of Flowserve products. The purchaser/user should read and understand the Installation Operation Maintenance (IOM) instructions included with the product, and train its employees and contractors in the safe use of Flowserve products in connection with the specific application.

While the information and specifications contained in this literature are believed to be accurate, they are supplied for informative purposes only and should not be considered certified or as a guarantee of satisfactory results by reliance thereon. Nothing contained herein is to be construed as a warranty or guarantee, express or implied, regarding any matter with respect to this product. Because Flowserve is continually improving and upgrading its product design, the specifications, dimensions and information contained herein are subject to change without notice. Should any question arise concerning these provisions, the purchaser/user should contact Flowserve Corporation at any one of its worldwide operations or offices.

For more information about Flowserve Corporation, contact [www.flowserve.com](http://www.flowserve.com) or call USA 1-800-225-6989.

**FLOWSERVE CORPORATION**  
**FLOW CONTROL DIVISION**  
1978 Foreman Drive  
Cookeville, Tennessee 38501 USA  
Phone: 931 432 4021  
Facsimile: 931 432 3105  
[www.flowserve.com](http://www.flowserve.com)