



Gas Flow Monitor CMG152/252/402/502 USA Model User's Manual



Thank you for purchasing this product.

This manual contains information for ensuring the correct use of this product. It also provides necessary information for installation, maintenance, and troubleshooting.

This manual should be read by those who design and maintain equipment that uses this product. Be sure to keep this manual nearby for handy reference.

Azbil Corporation

Please read "Terms and Conditions" from the following URL before ordering and use.

<http://www.azbil.com/products/factory/order.html>

IMPORTANT

"City gas" in this document refers to city gas in Japan.

NOTICE

Be sure that the user receives this manual before the product is used.

Copying or duplicating this user's manual in part or in whole is forbidden. The information and specifications in this manual are subject to change without notice.

Considerable effort has been made to ensure that this manual is free from inaccuracies and omissions. If you should find an error or omission, please contact the azbil Group.

In no event is Azbil Corporation liable to anyone for any indirect, special or consequential damages as a result of using this product.

© 2007-2016 Azbil Corporation All Rights Reserved.

The μ F™, CMG™, are trademark of Azbil Corporation in Japan.

Conventions Used in This Manual

- To prevent injury to the operator and others, and to prevent property damage, the following types of safety precautions are indicated:



WARNING

Warnings are indicated when mishandling this product might result in death or serious injury.



CAUTION

Cautions are indicated when mishandling this product might result in minor injury to the user, or physical damage to the product.

- In describing the product, this manual uses the icons and conventions listed below.



Use caution when handling the product.



The indicated action is prohibited.



Be sure to follow the indicated instructions.



Handling Precautions:

Handling Precautions indicate items that the user should pay attention to when handling the Gas Flow Monitor.



Note:







Notes indicate information that might benefit the user.

(1), (2), (3)







The numbers with the parenthesis indicate steps in a sequence or indicate corresponding parts in an explanation.

Safety Precautions





WARNING

	When using combustible gas, install the device upstream of the safety shut off valve. If air somehow enters the piping, and the sensor makes a spark due to some cause like a lightning strike when an explosive mixture is present, an explosion could occur inside the pipe.
	On flanged models, do not use the device or installed pipes as a footrest. Doing so might damage the device or piping, or cause a slip which might result in injury.
	Flanged models are heavy. Dropping them on your feet may cause injury.
	The device is intended for use with natural gas and air. Do not use the device for other types of gases. Use of the gases having an ignition temperature lower than 365 °C may cause an internal pipe explosion. A heater incorporated in a sensor could act as an ignition source if air has entered the piping and explosive mixed gas is produced.
	Use the analog outputs and alarm contact outputs on the device for monitoring the gas flow rate of a burner or other equipment. Do not use these outputs in applications where safety will be impaired when an analog output abnormality or alarm contact output malfunction occurs.
	Before wiring the device, be sure to turn the power OFF. Failure to do so might cause electric shock.

CAUTION

	This device is a precision instrument. Do not drop it nor subject it to shock. Doing so might damage the device.
	Do not peel off the pipe connection port seals until immediately before you connect the piping. Doing so might allow foreign objects to enter the connector port and cause defective operation.
	On rusty, welding fumes, slag, water droplet, oil mist or dusty piping, install a filter upstream to prevent foreign matter from entering the device. Foreign matter may cause faulty operation.
	When wiring, take care not to tug on the display. The components inside might become damaged.
	Be sure to use only rated fuses for replacement. Use of a non-rated fuse prevents the safety circuit from functioning properly.
	Be sure to check that the wiring is correct before you turn the power ON. Incorrect wiring may cause damage or malfunction.
	Connect the power supply last. Otherwise touching terminals by mistake may cause electric shock or damage the device.

! CAUTION

	Make sure that the load to be connected to terminals does not exceed the rating indicated in the specifications.
	Supply power at the voltage indicated on the model number label on the device.
	Take the necessary countermeasures with the instrumentation to prevent the occurrence of backfire and to avoid any influence to the device even if backfiring occurs. Pressure increase in the piping or fire caused by backfire of the burner could damage the device.
	When disposing of the device, observe local regulations.



Unpacking

Check the following items when removing the Gas Flow Monitor from its package:

1. Check the model number to make sure you received the correct product.
2. Check for any obvious damage.
3. Check the contents of the package against the packing list to make sure that all items are included.

Handle the Gas Flow Monitor and its accessories with care to prevent damage or loss of parts.

If there is some problem with your order, please contact your dealer immediately.

Name	Model No.	Q'ty	Remarks
Body	CMG _ _ _ _	1	 See, model selection guide, (page 2).
Plug	81503603-001	1	Attached to one of the wiring holes.
Packing seal	MPA-50003	1	
User's Manual 	CP-UM-5477E	1	This manual.

Contents

Conventions Used in This Manual

Safety Precautions

Unpacking

Chapter 1. INTRODUCTION

- Introduction..... 1
- Features..... 1
- Model selection guide..... 2

Chapter 2. NAMES AND FUNCTIONS OF PARTS

Chapter 3. MOUNTING AND WIRING

- Mounting 5
- Pipes..... 6
- Mounting position..... 7
- Wiring 9

Chapter 4. OPERATION

- Displaying the flow rate 12
- Resetting alarms..... 13
- Resetting the integrated flow rate 13
- Displaying the total flow rate 14

Chapter 5. ADVANCED OPERATION

- 5 - 1 Function Setup 15
 - Setting operation..... 15
 - Function setup item list 16
- 5 - 2 Parameter Setup..... 17
 - Setting operation..... 17
 - Parameter setup item list..... 18

Chapter 6. MAINTENANCE AND TROUBLESHOOTING

- Remediying trouble 20
- How to replace the fuse 21

Chapter 7. SPECIFICATIONS

- Common specifications 22
- Individual specifications 23
- China RoHS..... 25
- Pressure loss for air 26
- External dimensions 27

Chapter 1. INTRODUCTION

■ Introduction

The CMG gas flow monitor is a flowmeter for measuring the fuel flow rate of gas burners that use a Micro Flow sensor chip, a thermal flow speed sensor made using Azbil Corporation proprietary technology. The CMG displays and outputs the volume flow rate in a standard state* and does not require conversion for temperature and pressure. The CMG has the following functions: instantaneous flow rate display, integrated flow rate display, alarm contact output, instantaneous flow rate output according to analog output, integrated pulse or event output according to open collector output. These functions enable detailed air-fuel ratio management of burners and flow rate management of units.

* Factory setting is 32 °F, 1 atmosphere (The reference temperature can be selected from 41 °F, 50 °F, 59 °F, 68 °F and 77 °F, according to the function settings.)

■ Features

- Installation of the compact and high-precision CMG is simple. It can be mounted in any direction, as the direction of the display can be changed.
- Gas flow rate can be measured and managed easily on the digital flow rate display and Hi, Lo, OVER and ALARM LED displays.
- Display on panels and flow rate management can be performed easily using output of the gas flow rate upper/lower limit settings and analog output of instantaneous flow rate.
- Fuel usage can be easily understood because the instantaneous flow rate and integrated flow rate displays can be switched by one-touch operation.
The total flow rate since this device was installed can be displayed.
- Compensation of display values is not needed even if temperature and pressure change as the measurement method used is mass flow.
- A bypass structure using an orifice enables low pressure loss, and prevents the influence of mist, etc.
- Self-diagnostic functions simplify remedies during troubleshooting.

■ Model selection guide

CMG I II III IV V VI VII VIII IX

● Natural gas (13A) model (LNG CH₄: 88%)

Table	Selection						Description
	Model Number	CMG	↓	↓	↓	↓	
I	Piping size	15	○	—	—	—	1/2 inch
		25	—	○	—	—	1 inch
		40	—	—	○	—	1-1/2 inch
		50	—	—	—	○	1/2 inch
II	Connection method	2	○	○	○	○	NPT thread
III	Gas type	N	○	○	○	○	Natural gas
IV	Flow range	015	○	—	—	—	150 CFH (normal) *1
		100	—	○	—	—	1,000 CFH (normal) *1
		250	—	—	○	—	2,500 CFH (normal) *1
		500	—	—	—	○	5,000 CFH (normal) *1
V	Output	1	○	○	○	○	4 to 20 mA + Event
VI	Operating pressure	0	○	○	○	○	0 to 14.5 psi (100 kPa)
VII	Option-1	0	○	○	○	○	None
VIII	Power supply	0	○	○	○	○	24 V DC
IX	Option-2	0A	○	○	○	○	Fixed

● Air model

Table	Selection						Description
	Model Number	CMG	↓	↓	↓	↓	
I	Piping size	15	○	—	—	—	1/2 inch
		25	—	○	—	—	1 inch
		40	—	—	○	—	1-1/2 inch
		50	—	—	—	○	1/2 inch
II	Connection method	2	○	○	○	○	NPT thread
III	Gas type	A	○	○	○	○	Air
IV	Flow range	015	○	—	—	—	150 CFH (normal) *1
		100	—	○	—	—	1,000 CFH (normal) *1
		250	—	—	○	—	2,500 CFH (normal) *1
		500	—	—	—	○	5,000 CFH (normal) *1
V	Output	1	○	○	○	○	4 to 20 mA + Event
VI	Operating pressure	0	○	○	○	○	0 to 14.5 psi (100 kPa)
VII	Option-1	0	○	○	○	○	None
VIII	Power supply	0	○	○	○	○	24 V DC
IX	Option-2	0A	○	○	○	○	Fixed

*1 "Normal" refers to the volumetric flow rate (CFH) after converting to 32 °F, 1 atmosphere.

Chapter 2. NAMES AND FUNCTIONS OF PARTS

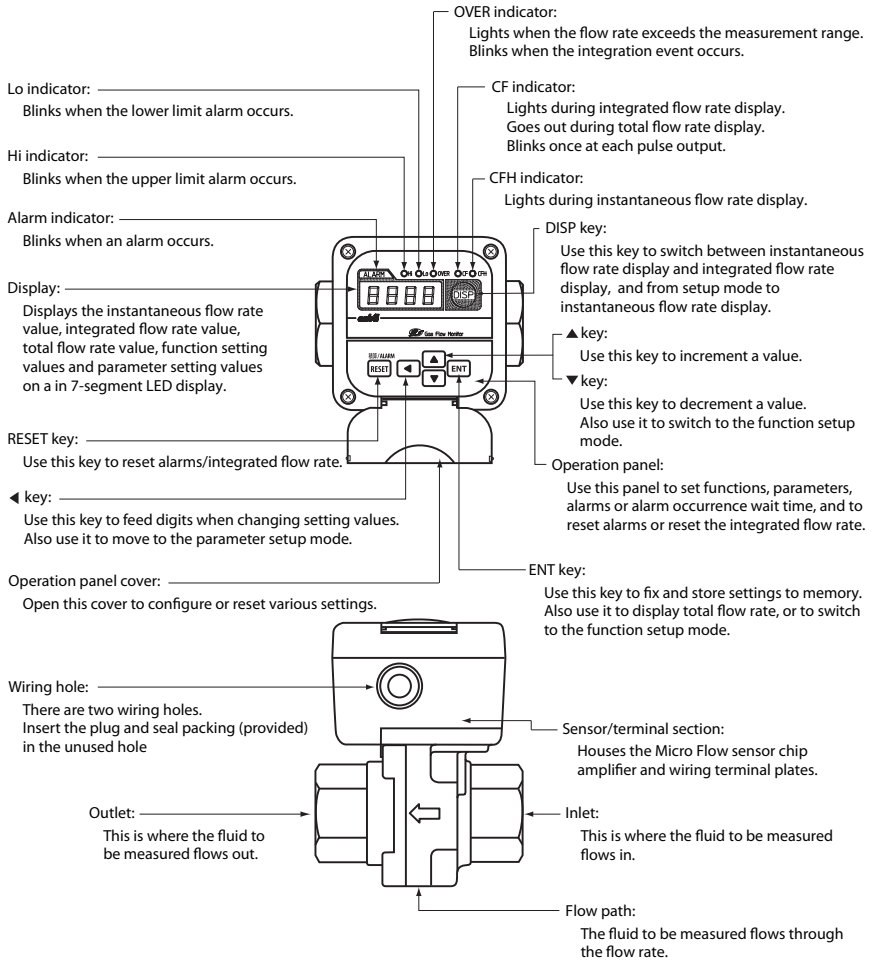

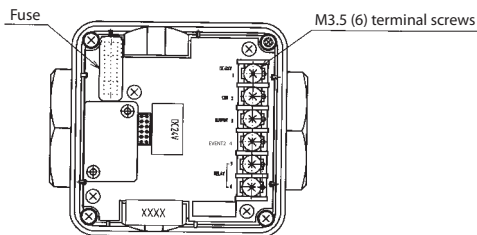

Fuse position



Chapter 3. MOUNTING AND WIRING

WARNING

-  When using combustible gas, install the device upstream of the safety shut off valve. If air somehow enters the piping, and the sensor makes a spark due to some cause like a lightning strike when an explosive mixture is present, an explosion could occur inside the pipe.
-  On flanged models, do not use the device or installed pipes as a footrest. Doing so might damage the device or piping, or cause a slip which might result in injury.
-  Flanged models are heavy. Dropping them on your feet may cause injury.

Handling Precautions

- When carrying the device, hold it by the flow path section. Holding it by the sensor/terminal section may damage the device.
- This device is a precision instrument. Do not drop it or subject it to shock. Doing so might damage the device.
- If the CMG model has a threaded pipe connection, when connecting the piping fasten the flow inlet/outlet section, and then screw in the pipe side to connect the piping.
- When connecting a flanged device, first check that the piping is not tilted or off center before installing. Failure to do so might cause leakage.
- To prevent vibration of the device, attach the pipe securely.
- Do not peel the protective seals from the display before use. When performing work on the device, tools may accidentally bump against the display and scratch it.
- When using the device outdoors, mount it out of the direct sunlight and in a location where it is not splashed directly by rain.
- When mounting the device in locations where rust, oil mist or dust and powder exists, be sure to provide a strainer or filter upstream to prevent foreign matter from entering the device. Foreign matter flowing into the device might result in faulty operation.
- When wiring the device, take care not to tug on the display. The internal connections might become damaged.
- Wire 4-20 mA output and open collector output separately from the power line and power supply leads. Do not wire these outputs in the same conduit as the power line and power supply leads. Doing so might cause malfunction.
- Install a switch for shutting off the main power to the device within reach of the person operating the device.
- The common mode voltage between output and ground should be less than 33 V RMS, 46.7 V at peak or 70 V DC, excluding power supply and relay contact output.

■ Mounting

● Installation site

Avoid mounting the CMG in locations characterized by the following:

1. Operating temperatures that fall below 14 °F and rise above 140 °F
2. Operating humidity that exceeds 90 %RH
3. Sudden changes in temperature and condensation
4. Corrosive gases and flammable gases
5. Abundant conductive substances (e.g., dust, salt or iron dust) or organic solvents
6. Vibration or shock
7. Direct sunlight
8. Direct splashing by rain or water
9. Splashing by fluids (e.g., oil, chemicals)
10. Strong magnetic or electrical fields
11. Where there is a pulsating flow.
 - (1) One cause is flexible piping (regardless of the material) with an accordion-shape inner surface and a length of 500 mm or more. Flexible piping (such as a rubber hose) with a flat inner surface does not cause pulsation.
 - (2) Another cause is a reciprocating or rotary type gas booster or a flow meter having rotary motion like a Roots meter.
12. Where soot or moisture generation in the piping is expected due to fluctuation in gas composition, etc.

● Gas flow

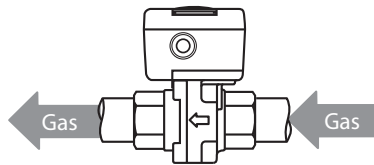

❗ Handling Precautions

- Make sure that the gas flows into the device in the direction indicated by the FLOW arrow on the side of the flow path. Otherwise, the flow rate cannot be measured correctly.

■ Pipes

● Precautions for piping installation

This device is a precision instrument. If foreign matter such as dust, oil mist or water enters the device, it may cause measurement error or faulty operation. When installing piping, be sure to follow the procedures below to prevent foreign matter from entering the device.

1. Before installing the device, be sure to flush the upstream and downstream piping thoroughly to remove welding fume particulate and dust.
2. Be sure to wipe the inside of the pipe to be directly connected to this device.

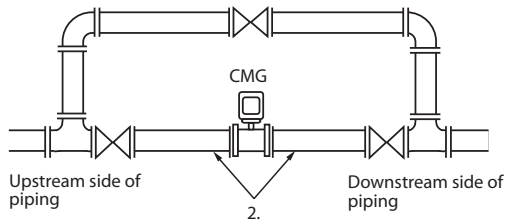

3. After the above two operations are complete, check to be sure that there is no welding fume particulate or dust, and then install the device.

❗ Handling Precautions

- If foreign matter cannot be fully eliminated by flushing or wiping, or if the regular presence of foreign matter can be expected, be sure to install a filter. If dust, oil or moisture adheres to the Micro Flow sensor chip, measurement error or faulty operation may result.

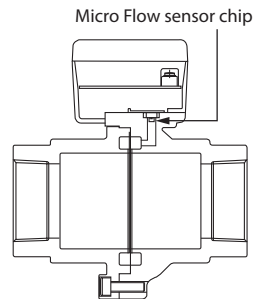

● Straight pipe section

To be sure the straight pipe section is long enough, refer to

👉 pages 23-24.

■ Mounting position

⚠ CAUTION

- ⊘ • Do not mount so that the display is facing down. Doing so might cause error or other malfunction.
- This device can be used with the display facing up $\pm 90^\circ$.

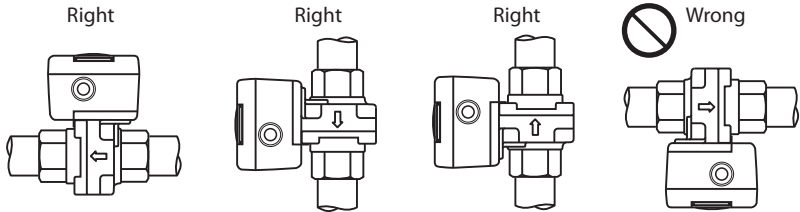

⚠ Handling Precautions

- The length of the required straight pipe connection varies according to the model number. For details, refer to  ■ Individual specifications (page 23).

● Screw connection

● Coating sealant

Coat with an appropriate amount of sealant. Do not coat the top two threads of the screw.

Remove any dirt, burrs or piping cutting oil from inside the pipes.

⚠ Handling Precautions

- Do not overdo the sealant, and do not allow dirt, burrs or piping cutting oil to enter the pipes, as this might cause measurement error.

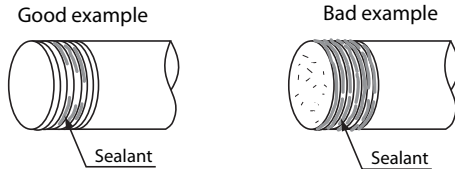

● **Connecting pipes**

Connect pipes while gripping the hexagonal section of the pipe connection port on the body with a wrench.

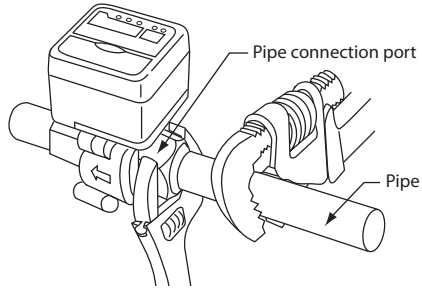

! **Handling Precautions**

- Do not grip the display or sensor/terminal section. Doing so might damage the body or cause leakage.
- Do not tighten the pipe at a torque that exceeds the maximum tightening torque.

Model No.	Max. Tightening Torque
CMG152	50 N·m
CMG252	125 N·m
CMG402	200 N·m
CMG502	250 N·m

■ **Wiring**

⚠ CAUTION

- ⊘ Prevent the load connected to the output terminal from exceeding the rating indicated in the specifications. Failure to do so might cause damage.
- ⚠ Be sure to check that the wiring is correct before you turn the power ON. Incorrect wiring might cause damage or malfunction.

The following table describes the meaning of symbols indicated on the terminal layout label on the CMG:

Symbol	Meaning
---	Direct current

● **Removing the operation panel/display**

Required tool: Phillips screwdriver

- (1) Loosen the four screws on the operation panel/display using the Phillips screwdriver.
- (2) Gently lift up the operation panel/display, and disconnect its power lead connectors.

● **Wiring**

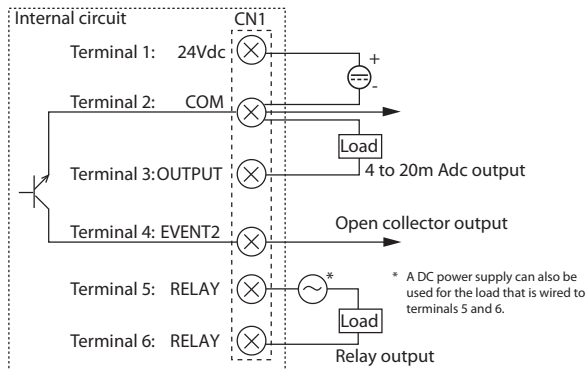

Terminal No.	Signal Name	Description
1	24 V DC	Power supply
2	COM	Common
3	OUTPUT	Analog output 4 to 20 mAdc
4	EVENT2	Event output 2 NPN open collector, integrated pulse
5	RELAY	Event output 1 contact output (relay output)
6	RELAY	Event output 1 contact output (relay output)

Handling Precautions

- Use crimped terminal lugs, which enable a reliable connection to terminals.
- Use crimped terminal lugs that are compatible with M3.5 screws.
- Limit the terminal screw tightening torque to 0.8 N·m.
- Use a JIS C 3401 control cable (CVV, etc.) of maximum outer diameter of 2.2 mm for wiring.
- If waterproofing is required, be sure to use the seal connector (Azbil Corporation model: PA4-N2, PA4-N4 or equivalent product) for reliable sealing.
- When wiring to terminal 2 (COM), wire the analog output lead separately from the power lead. Otherwise, a voltage drop caused by the power current may influence the accuracy of the analog output.
- Take care that event output 2 (the open collector output) does not exceed the output rating of this device. When driving a relay, be sure to use one with a built-in coil surge absorption diode. Failure to do so might cause faulty operation.

● Mounting the operation panel/display

On this device, the operation panel/display can be rotated up to $\pm 180^\circ$ to an easy- to-view position. Follow the procedure below to mount the operation panel/display:

- (1) Connect the connectors of the leads from the operation panel/display to the sensor/terminal section.
- (2) Rotate the display to the most easily visible position.
- (3) Fasten the operation panel/display onto the sensor/terminal section with screws.

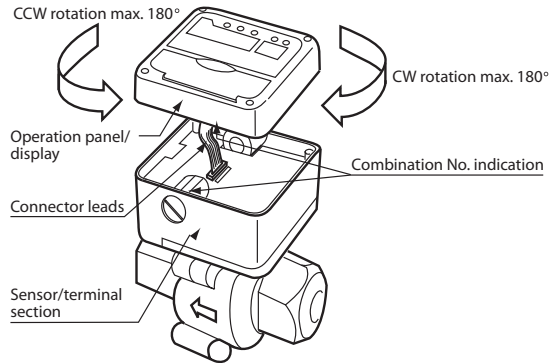

! Handling Precautions

- The maximum screw tightening torque is 1.0 N·m. The IP54 seal might be impaired if screws are too tight or too loose.
- Arrange the leads connecting the sensor/terminal section and the operation panel/display so they are not unnecessarily twisted or pinched when fitting the sections together.
- Prevent the leads connecting the sensor/terminal section and the operation panel/display from being damaged.
- Do not rotate the operation panel/display beyond 180° to the left or right. This section may be rotated to the left or right if it is mounted upside down.
- Use an operation panel/display and a sensor/terminal section with the same combination of combination numbers. Combination numbers differ from device to device as each device is adjusted individually. If different combination numbers are combined, accuracy can no longer be guaranteed. The combination numbers are each displayed on the operation panel/display and sensor/terminal section.

Chapter 4. OPERATION

⚠ CAUTION

Do not operate the keys with a mechanical pencil, screwdriver or other sharp-tipped object. Doing so might damage the keys.

■ Displaying the flow rate

The following values can be alternated on the 4-digit, 7-segment LED display:

1. Instantaneous flow rate
2. Integrated flow rate

The following shows the operation flow for displaying the flow rate:

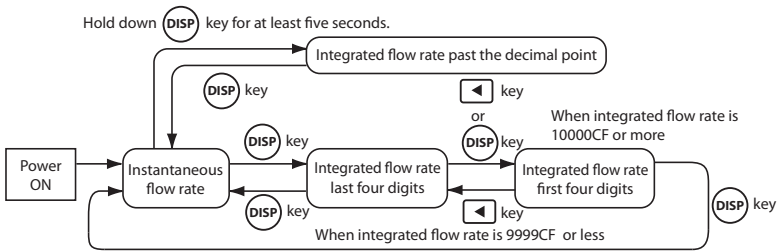

● Displaying the instantaneous flow rate and integrated flow rate

When the power is turned ON, the CFH indicator lights to indicate the instantaneous flow rate. To display the integrated flow rate, press the **DISP** key.

>> • The CF indicator lights to indicate the integrated flow rate.

- The display is a 4-digit display. However, the integrated flow rate is displayed as eight digits, divided into the first four digits and the last four digits. In all, an integrated flow rate up to **99999999** can be displayed.
- When the last four digits are displayed, the decimal point lights to the right of the last digit.

When the integrated flow rate is **9999** CF or less, pressing the **DISP** key again returns the display to the instantaneous flow rate display. When the integrated flow rate is **10000** CF or more, pressing the **DISP** key displays the first four digits of the integrated flow rate. You can also alternately display the first four digits and the last four digits by repeatedly pressing the **◀** key.

For example, if initial reading is **1234** and the 2nd reading is **. . 56**, the integrated flow rate is **. . 561234** CF.

If the **DISP** key is held down for at least five seconds when switching to the integrated flow rate display from the instantaneous flow rate display, digits past the decimal point for the integrated flow rate are displayed.

! Handling Precautions

- When the flow rate exceeds the upper limit of the measurement range, the OVER indicator light, and goes out after the flow rate returns to within the measurement range.
- The integrated flow rate factory setting is 0.
- The integrated flow rate indication returns to 0 after 99999999 is exceeded.
- The flow rate is integrated even if the flow rate is outside of the measurement range. Regard integrated values as a means for grasping the whole quantity of flow.

■ Resetting alarms

When a flow rate alarm detection condition is selected (an item from 1 to 5 in function setup item 7 - 02; see page 16), an alarm is set.

To reset the alarm, press the **RESET** key.

>> The alarm indicator goes out, and the alarm output relay turns OFF.

! Handling Precautions

- Alarms are also reset by turning the power OFF.
The alarm recurs after the alarm occurrence wait time when the flow rate exceeds the preset alarm value after the flow monitor is re-energized.

■ Resetting the integrated flow rate

Hold the **RESET** key down for at least two seconds while the integrated flow rate is displayed.

>> The integrated value becomes 0.

! Handling Precautions

- Holding down the **RESET** key for two seconds or more while an alarm is occurring merely stops the alarm; it does not reset integrated values. In this case, reset the alarm after the flow rate has returned to within the preset alarm range, and then hold down the **RESET** key again for two seconds or more.

■ Displaying the total flow rate

This function displays the total flow rate since the device was installed. Reset cannot be performed by the same reset operation used for integrated flow rate.

- (1) Press the key until the integrated flow rate is displayed.
>> The CF indicator lights.
- (2) Hold the **DISP** key for one second or more.
>> The CF indicator goes out, and the total flow rate is displayed for 5 seconds.
The total flow, like the integrated flow rate, is displayed in the divided upper four digits and lower four digits, in total 8 digits capable of displaying the maximum **99999999** CF.
After that, the CF indicator automatically lights, and the display returns to the integrated flow rate display.
- (3) Press the **DISP** key again within five seconds while it is displayed.
>> The first four digit display.

You can also alternately display the first four digits and the last four digits by using the **▲** key repeatedly.

! Handling Precautions

- The total flow rate indication returns to **0** after **99999999** is exceeded.
- Integrated flow rate and total flow rate values are held in memory even if the power is turned OFF.
On models that display values down to two digits past the decimal point, data is written into memory when the ones digit changes or one hour after the previous writing.
On models that display values down to one digit past the decimal point, data is written into memory when the tens digit changes or one hour after the previous writing.
Integrated values that have not been written to memory are discarded when the power is turned OFF.
- The total flow rate reset setting can be configured to either the enabled or disabled condition using the function setup.
- If the “Reset is performed by key switch” setting has been selected, press the **RESET** key for 2 seconds or more while displaying the total flow rate.
The total flow rate and integrated flow rate will be reset and initialized to “0”.

Chapter 5. ADVANCED OPERATION

5 - 1 Function Setup

■ Setting operation

Follow the procedure below to set functions such as alarm detection and event output assignments.

- (1) Press the **DISP** key to display the instantaneous flow rate.
>> The CFH indicator lights.
- (2) Hold the **▼** and **ENT** keys down simultaneously for 3 seconds.
>> Item No. $\zeta - \text{CF}$ is displayed on the 7-segment display, and the mode changes to function setup mode.
- (3) Press the **▲** or **▼** key to select the desired setup item, and press the **ENT** key.
>>The current setting blinks on the 7-segment display.
- (4) Press the **▲** or **▼** key to select the desired setting.
- (5) When the desired setting has been selected, press the **ENT** key to finalize the setting.
>> After approx. one second, the item number is redisplayed, and the setting is updated.
- (6) If there are other required setup items, return to step (3) above to repeat the procedure. If there are no other setup items, proceed to step (7).
- (7) Press the **DISP** key.
>> The display changes from the function setup mode to the instantaneous flow rate display.

❗ Handling Precautions

- If you do nothing for one minute after entering the function setup mode, the display automatically returns to the instantaneous flow rate display.
- If you press the **DISP** key without pressing the **ENT** key after carrying out the operation in step (4), the setting remains at the previous value without being updated.

■ Function setup item list

Display	Function	Settings description		Factory setting	Remarks
└ - 01	Key lock	0: Key lock disabled 1: All settings key-locked		0	The key lock can be disabled even while it is enabled.
└ - 02	Flow rate alarm detection condition selection	0: Alarm detection is not performed. 1: Only the upper limit alarm is detected. 2: Only lower limit alarm 1 is detected. 3: Upper limit alarm and lower limit alarm 1 are detected. 4: Only lower limit alarm 2 is detected. 5: Upper limit alarm and lower limit alarm 2 are detected.		0	The alarm detection flow rate is set in the parameter setup mode. Lower limit alarm 1: A flow rate less than the lower limit of the measurement range is not judged to be an alarm. Lower limit alarm 2: A flow rate less than the lower limit of the measurement range is judged to be an alarm.
└ - 03	Event output 1 (relay) function assignment	0: Not used (OFF at all times) 1: ON when upper limit alarm occurs 2: ON when lower limit alarm occurs 3: ON when upper limit alarm or lower limit alarm occurs 4: ON when integration event occurs		3	
└ - 04	Event output 2 (open collector) function assignment	0: Not used (OFF at all times) 1: ON when upper limit alarm occurs 2: ON when lower limit alarm occurs 3: ON when upper limit alarm or lower limit alarm occurs 4: ON when integration event occurs 5: Integrated pulse output		5	
└ - 05	Flow rate alarm reset method selection	0: Only reset by key switch 1: Reset by key switch or automatic reset by normal recovery of flow rate		0	
└ - 06	Integrated flow rate reset method selection	0: Reset disabled. 1: Reset by key switch only 2: Only automatic reset after the integration reset delay time when the integration event occurs 3: Reset by key switch or automatic reset after the integration reset delay time when the integration event occurs		1	
└ - 07	Total flow rate reset method selection	0: Reset disabled. 1: Reset by key switch		0	The integrated flow rate is also reset when the total flow rate is reset.
└ - 08	Reference temperature selection	0: 32°F 1 atmosphere 1: 41°F 1 atmosphere 2: 50°F 1 atmosphere 3: 59°F 1 atmosphere 4: 68°F 1 atmosphere 5: 77°F 1 atmosphere		0	The reference temperature of the flow rate output can be switched.
└ - 09	Pulse rate selection	CMG152/252	CMG402/502	3	CMG152/252: Do not set except 2 and 3. CMG402/502: Do not set except 3.
		0: Disabled. 1: Disabled. 2: 0.1 CF/1 pulse 3: 1 CF/1 pulse	0: Disabled. 1: Disabled. 2: Disabled. 3: 1 CF/1 pulse		

5 - 2 Parameter Setup

■ Setting operation

Follow the procedure below to set parameters such as the flow rate alarm upper and lower limit values and alarm detection delay times.

- (1) Press the **(DISP)** key to display the instantaneous flow rate.
>> The CFH indicator lights.
- (2) Hold the **(◀)** key down for 3 seconds.
>> Item [A,HI] is displayed on the 7-segment display, and the mode changes to parameter setup mode.
- (3) Press the **(▲)** or **(▼)** key to select the desired setup item, and press the **(ENT)** key.
>> The current setting blinks on the segment display.
- (4) Press the **(▲)** or **(▼)** key to change to the desired value. The digit to be changed can be moved by using the **(◀)** key.
- (5) When the desired setting has been selected, press the **(ENT)** key to finalize the setting.
>> After approx. one second, the item number is redisplayed, and the setting is updated.
- (6) If there are other required setup items, return to step (3) above to repeat the procedure. If there are no other setup items, proceed to step (7).
- (7) Press the **(DISP)** key.
>> The display changes from the parameter setup mode to the instantaneous flow rate display.

! Handling Precautions

- If there is no input for one minute after the parameter setup mode begins, the display automatically returns to the instantaneous flow rate display.
- If you press the **(DISP)** key without pressing the **(ENT)** key after carrying out the operation in step (4), the setting remains at the previous value without being updated.

■ Parameter setup item list

No.	Item displayed	Item Description	Factory Setting	Setting Range	Remarks
1	<i>R.HI</i> *1	Instantaneous flow rate upper limit alarm	(Upper limit of measurement range) CFH (normal)	(0 to 150 % of measurement upper limit) CFH (normal)	Selection of an alarm detection condition is required in function setup $\zeta - 02$.
2	<i>R.H.HY</i>	Hysteresis for instantaneous flow rate upper limit alarm	(Within 2 % of measurement upper limit) CFH (normal)	(0 to 100 % of measurement upper limit) CFH (normal)	
3	<i>R.Lo</i> *2	Instantaneous flow rate lower limit alarm	(Lower limit of measurement range) CFH (normal)	(0 to 100 % of measurement upper limit) CFH (normal)	
4	<i>R.L.HY</i>	Hysteresis for instantaneous flow rate lower limit alarm	(Within 2 % of measurement upper limit) CFH (normal)	(0 to 100 % of measurement upper limit) CFH (normal)	
5	<i>R.dLY</i>	Delay timing for instantaneous flow rate alarm judgment	60.0 s	0.0 to 999.9 s	
6	<i>E.SP.L</i>	Integration event setup (lower four digits)	0 CF	0 to 99,999,999 CF	Value set is valid only when selecting integration event output in either $\zeta - 03$ or $\zeta - 04$ of function setup.
7	<i>E.SP.H</i>	Integration event setup (upper four digits)			
8	<i>E.C.dL</i>	Integration reset delay time	10.0 s	0.0 to 999.9 s	Value set is valid only when selecting automatic reset by integration reset delay in $\zeta - 05$ of function setup.
9	<i>b.BRS</i>	Instantaneous flow rate bias (PV bias)	0 CFH	(-20 to +20 % of measurement upper limit) CFH (normal)	
10	<i>oUL.H</i>	Instantaneous flow rate output 20 mA scaling	(Upper limit of measurement range) CFH (normal)	(0 to 150 % of measurement upper limit) CFH (normal)	
11	<i>oUL.L</i>	Instantaneous flow rate output 4 mA scaling	0 CFH	(0 to 100 % of measurement upper limit) CFH (normal)	
12	<i>GRS.C</i>	Gas composition compensation coefficient	1.000	0.100 to 4.000	

Note) "Normal" refers to the volumetric flow rate (CFH) after converting to 32 °F, 1 atmosphere.

! Handling Precautions

- *1 Be certain to set a flow rate that is less than the display upper limit. Alarm detection will not operate if flow rate is set above the display upper limit.
- *2 If "lower limit alarm1" has been selected in function setup $\zeta - 02$, alarm detection will not operate when the flow rate is less than the lower limit of the measurement range, even if the flow rate is below the lower limit alarm value.

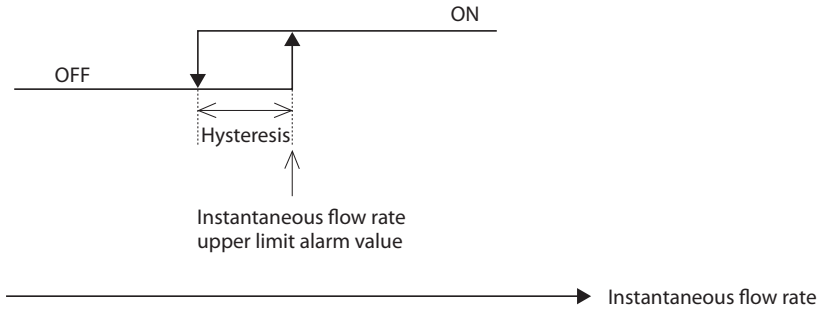
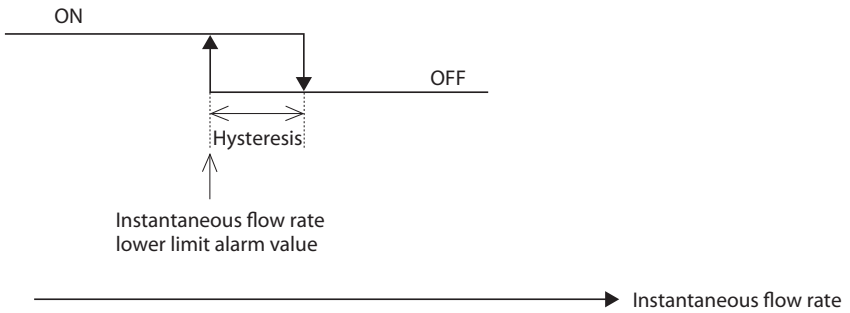
● Instantaneous flow rate upper limit alarm operation**● Instantaneous flow rate lower limit alarm operation**

Chapter 6. MAINTENANCE AND TROUBLESHOOTING

■ Remediating trouble

When trouble occurs, refer to the following table:

Problem	Remedy
Nothing is displayed.	<ul style="list-style-type: none"> • Make sure that the power supply voltage and polarity are correct. • Check the connectors connecting the display to the sensor/terminal section for disconnection or faulty contact. • Check the fuse to see if it has blown. If so replace it. For details on how to replace the fuse, see the next item ■ How to replace the fuse.
Err1 is displayed alternately with the flow rate value.	<ul style="list-style-type: none"> • Check the connectors connecting the display to the sensor/terminal section for disconnection and faulty contact. • If the connectors are free of abnormalities, a probable cause is sensor error. Contact the azbil Group for repair.
Err2 is displayed alternately with the flow rate value.	<ul style="list-style-type: none"> • The probable cause is an error in the memory, which is individually adjusted for each sensor. Err2 is displayed, but the operation continues with provisional data in spite of the error. Readjustment by Azbil Corporation is necessary.
The display is other than 0.00 (including a minus display) even though the instantaneous flow rate should be zero.	Check the shut-off valve and piping for any leaks. If the valve and piping are free of leaks, a probable cause is that the device's characteristics have changed. Contact the azbil Group for repair.
A minus is displayed for the instantaneous flow rate.	Make sure that the arrow marked on the flow path matches the direction of gas flow. Correct the directions if it is reversed.
Indicated flow rate varies significantly.	<ul style="list-style-type: none"> • Check that the straight pipe section is long enough. • If the problem seems to be foreign matter stuck to the sensor or the effects of a pulsating flow, contact the azbil Group.

! Handling Precautions

- Err2 (memory error) indicates that the individual adjustment data for the flowmeter's internal sensor has been lost. Accuracy cannot be guaranteed if use of the flowmeter is continued in this state. Ask for repair.

■ How to replace the fuse

⚠ CAUTION

- ❗ When touching internal parts, touch a grounded metal part to discharge static electricity from the body. Otherwise, static electricity may damage components.
- ❗ Before replacing the fuse, be sure to turn the power OFF. Failure to do so might cause electric shock.
- ❗ Be sure to use a fuse having an electrical rating of 250 V, and 0.5 A for replacement. Use of a non-rated fuse prevents the safety circuit from functioning properly.

● Needed items

Phillips screwdriver

Fuse:

Made by Cooper Bussmann U K Ltd: Model No. S504 500 mA
(250 V, 0.5 A)

Made by Littelfuse: Model No. 218.500 (250 V, 0.5 A)

Standard	IEC127
Fuse blowout speed	Time-lag
Rated voltage	250V
Rated current	0.5A

● Replacement procedure

- (1) Loosen the four screws on the operation panel/display.
- (2) Gently lift up the operation panel/display.
- (3) Remove the fuse cover. For details, refer to  Chapter 2. NAMES AND FUNCTIONS OF PARTS.
- (4) Remove the fuse.
- (5) Attach the new fuse.
- (6) Attach the fuse cover.
- (7) Attach the operation panel/display in its original position on the sensor/terminal section.

❗ Handling Precautions

- When a fuse blows, check for abnormal power voltage, miswiring, or other causes of the fuse having blown.
- Replacement of parts is precision work. Take sufficient care not to lose or damage removed components.

Chapter 7. SPECIFICATIONS

Common specifications

Item	Specifications
Applicable gas	Natural gas *, air (according to model No.)
Material	Flow path section: aluminum alloy (NPT thread) Display section: PBT (GF 30 %)
Instantaneous flow rate display accuracy	Measurement range Accuracy: $\pm 4 \%RD \pm 1$ digit (50 to 104 °F) $\pm 6 \%RD \pm 1$ digit (14 to 140 °F)
Pressure range	Less than 14.5 psi
Pressure resistance	22 psi
Allowable ambient temperature, gas temperature	14 to 140 °F (no freezing allowed)
Storage ambient temperature	-4 to +158 °F (no freezing allowed)
Allowable ambient humidity	104 °F, 90 %RH or less (no condensation allowed)
Rated voltage	24 V DC
Allowable voltage	24 V DC ± 10 %
Power consumption	5.5 W or less
Flow rate display method	Flow quantity adjusted for 32 °F and 1 atmospheric pressure
Instantaneous flow rate repeatability	$\pm 1 \%RD \pm 1$ digit (68 °F)
Response speed	Sampling cycle 100 ms, 0→100 % step response 1.6 s
Instantaneous flow rate output (4 to 20mA dc)	Output range: 0 to 400 % of measurement range upper limit (scalable) Accuracy: ± 0.5 %FS Load resistance: 300 Ω max.
Event output 1	1a contact (closes at event generation) Contact rating: 250 V AC, 30 V DC, 5 A (resistance load) Mechanical life: 20 million cycles Electrical life: 70,000 cycles
Event output 2	Output configuration: NPN open collector output Output rated: 30 V 50 mA max. When integrated pulse output is selected: Pulse width: 100 ms ± 20 % For measurement to 2 digits after the decimal point range: Select either a 0.001 CF/pulse, 0.01 CF/pulse or 0.1 CF/pulse For measurement to 1 digit after the decimal point range: Select either a 0.01 CF/pulse, 0.1 CF/pulse or 1 CF/pulse
Conduit size	G 1/2, 2 pieces
Vibration resistance	5m/s ² or less, 10 to 60Hz, for 2 hours each in X, Y and Z directions
Shock resistance	500m/s ² or less, 3 times each in X, Y and Z directions
Voltage resistance	Between terminal 5 and flow path, and between terminal 6 and flow path: 1500 V AC for 1min or 1800 V AC for 1s
Insulation resistance	Between each terminal and flow path metal parts: min. 50 M Ω (500 V DC megger)

Item	Specifications
Protection	IP54 (JIS C 0920) splash-proof and dustproof structure
Applicable standards	EN61326-1: 2006, EN61326-2-3: 2006, EN61010-1: 2001
Over-voltage category	Category II
Pollution degree	Pollution degree 2
Altitude	2000 m or less

* In Japan, natural gas is adjusted to either of the specifications shown below. If the composition of the natural gas that you use does not match either of these types, please contact Azbil Corporation.

Gas type (as used Azbil Corporation)	Methane (%)	Ethane (%)	Propane (%)	Butane (%)
Natural gas 13A-46MJ	88	5.8	4.5	1.7
Natural gas 13A-45MJ	88.9	6.8	3.1	1.2

Individual specifications

Item	Specifications			
Model No.	CMG152	CMG252	CMG402	CMG502
Pipe size and connection	1/2 NPT thread	1 NPT thread	1-1/2 NPT thread	2 NPT thread
Measurement range (CFH(normal))	17.0 to 150.0	100 to 1,000	250 to 2,500	500 to 5,000
Indication range (CFH(normal))	0.0 to 240.0	0.0 to 1,200	0 to 3,500	0 to 6,000
Straight piping length	(No need)	6 inch min.	4 inch min.	16 inch min.
Mask color	Natural gas model: Yellow		Air model: Blue	
Mass	Approx. 850 g	Approx. 800 g	Approx. 2.1 kg	Approx. 2 kg

- *1: The number of digits displayed after the decimal point for CFH is the same as that shown in the table.
- *2: "Normal" refers to the volumetric flow rate CFH after converting to 32 °F, 1 atmosphere.
- *3: The measurement range is the flow rate range in which instantaneous flow rate display accuracy is stipulated.
- *4: Straight pipe longer than the length specified above may be required depending on the pipe shape or other devices mounted on the piping. The length of downstream straight pipe section is a standard value.

Straight pipe section (rough guidelines)

● Same diameter pipe (diameters A and B are the same)

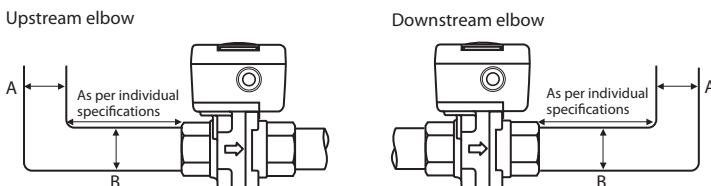

● Different diameter pipe (diameter A is different from diameter B)

D: inner dia. connecting pipe

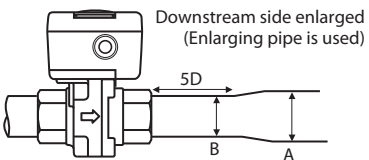
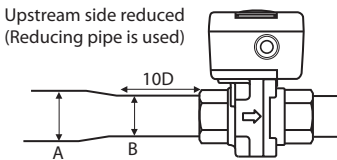
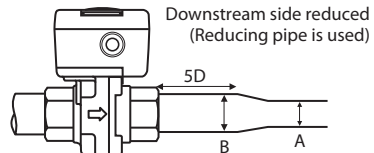
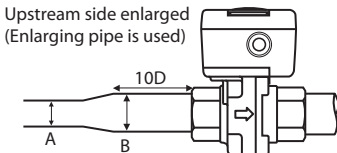
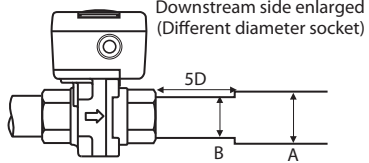
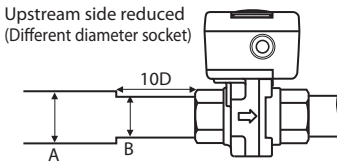
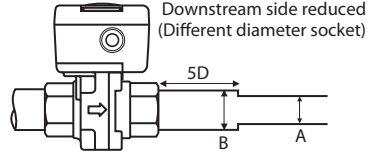
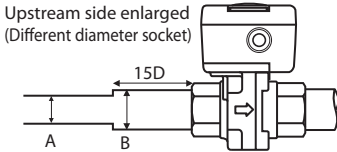

● Valves (fully open)

D: inner dia. connecting pipe

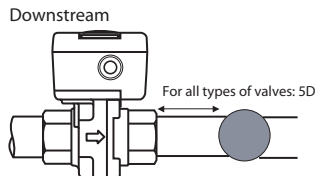
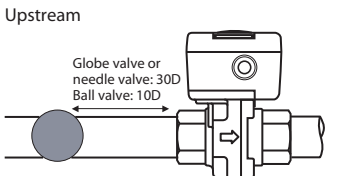

❗ Handling Precautions

- In case of globe, butterfly or needle valves, which cause disturbance or fluctuations to the flow, a straight pipe length of more than 30D is required. Install a flow-adjusting valve as far downstream of the CMG as possible. Contact the azbil Group for valves other than the above.

■ China RoHS

基于SJ/T11364-2014「电子电气产品有害物质限制使用标识要求」的表示式样
产品中有害物质的名称及含量

部件名称	有害物质					
	铅 (Pb)	汞 (Hg)	镉 (Cd)	六价铬 (Cr(VI))	多溴联苯 (PBB)	多溴二苯醚 (PBDE)
电路板	×	○	○	○	○	○
流路部件 (流路中与气体接触的部件) 注1	×	○	○	○	○	○
本表格依据SJ/T 11364 的规定编制。 ○：表示该有害物质在该部件所有均质材料中的含量均在GB/T 26572规定的限量要求以下。 ×：表示该有害物质至少在该部件的某一均质材料中的含量超出GB/T 26572规定的限量要求。 注1 CMG401,CMG501为非含有						



■ Pressure loss for air

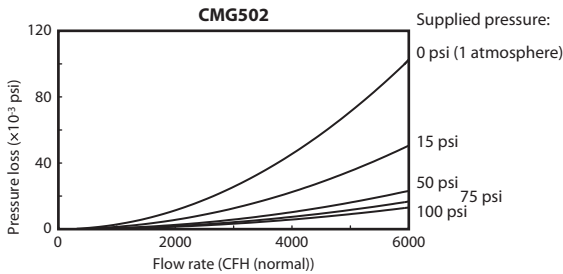
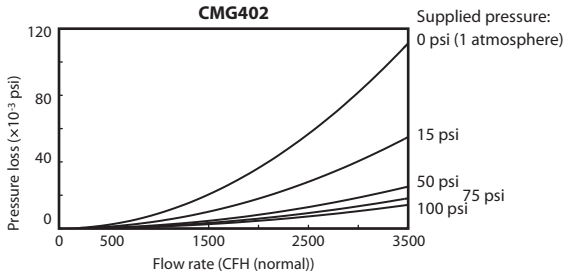
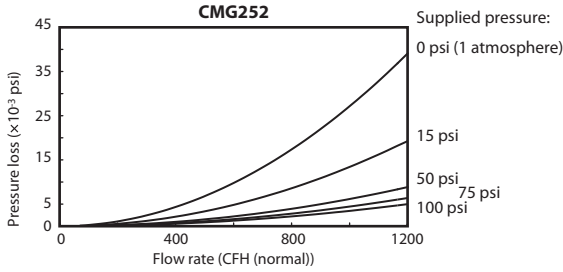
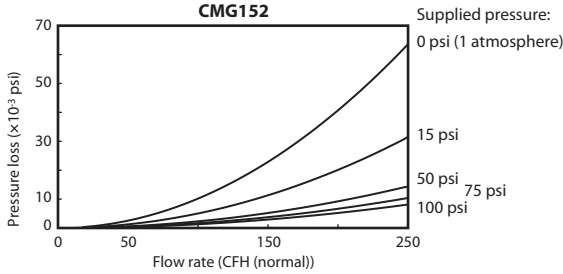

- Note:
- The pressure loss varies with the supplied pressure. Determine the pressure loss based on the pressure curve(s) most near to the actual supplied pressure.
 - The pressure loss of the natural gas can be obtained by multiplying the above pressure loss by the specific gravity of natural gas, 0.64.

External dimensions

Unit: inch

● CMG152/252

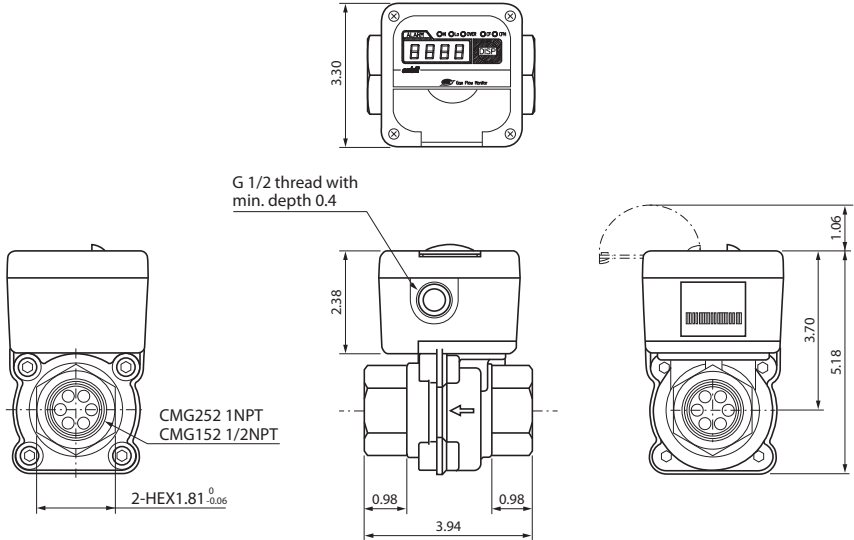

● CMG402/502

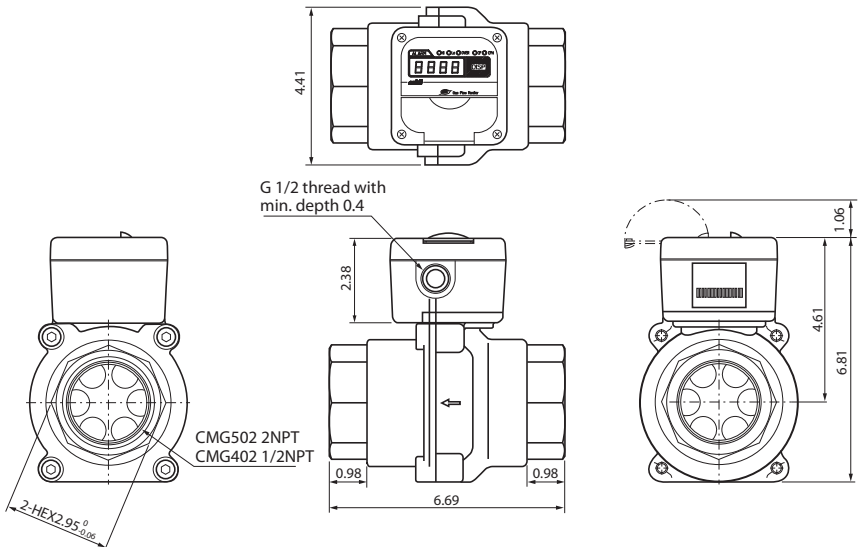



Specifications are subject to change without notice. (09)

Azbil Corporation
Advanced Automation Company

1-12-2 Kawana, Fujisawa
Kanagawa 251-8522 Japan

URL: <http://www.azbil.com>

1st edition: Apr. 2007
3rd edition: June 2016 (V)