

▶ RCG90-100 ◀

Pneumatic Actuators

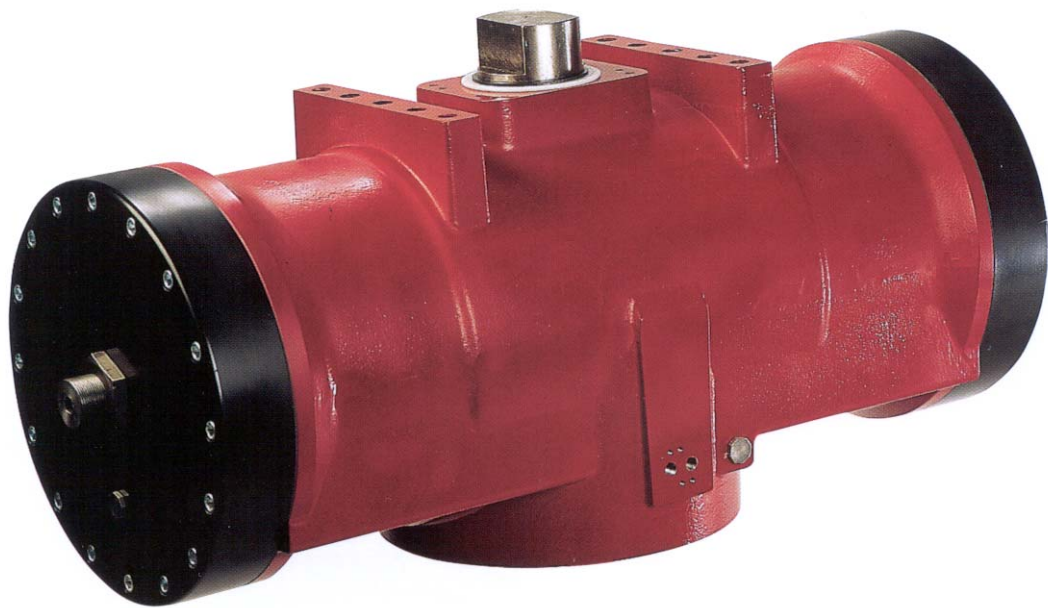

For demanding applications

- ▶ Strong, compact actuators for large valves and high torques
- ▶ Epoxy coated ductile iron in cylinder, end plates and spring housing
- ▶ Inside of cylinder Teflon lined for low friction and high corrosion protection
- ▶ Connection according to DIN3337/ISO5211 to valve
- ▶ Connection according to VDI/VDE3845 to solenoid valve
- ▶ Prepared for quick operation (extremely fast emergency)
- ▶ Optional: Manual override

RCG-DA

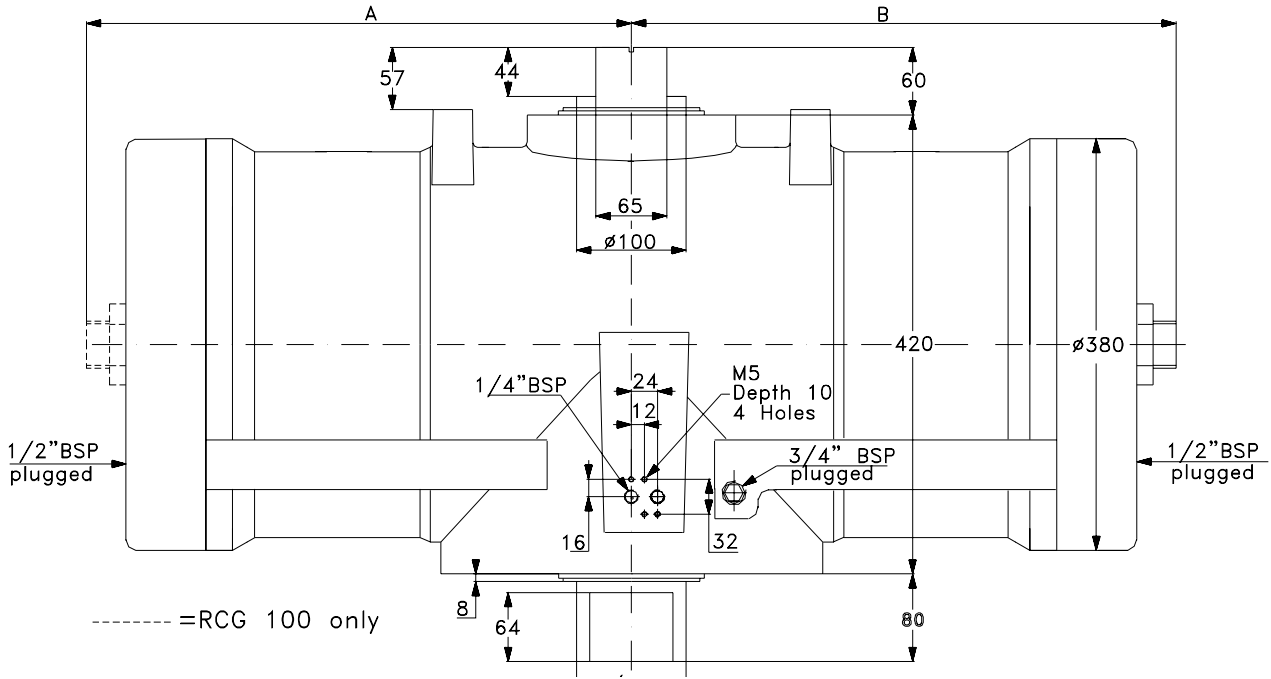

Mounting face

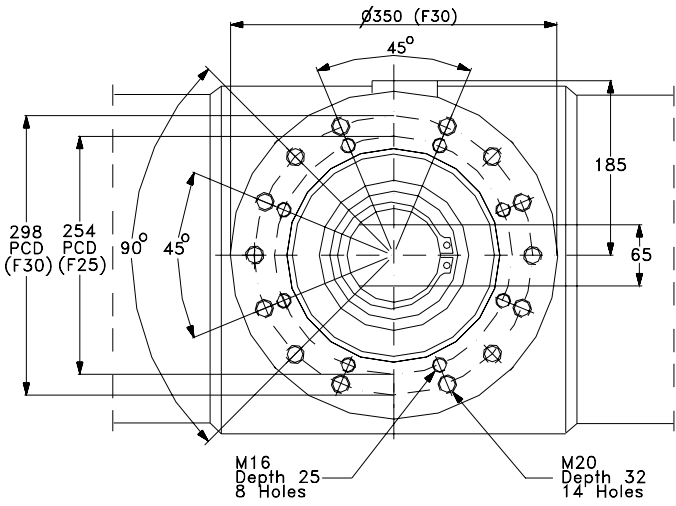

Top side

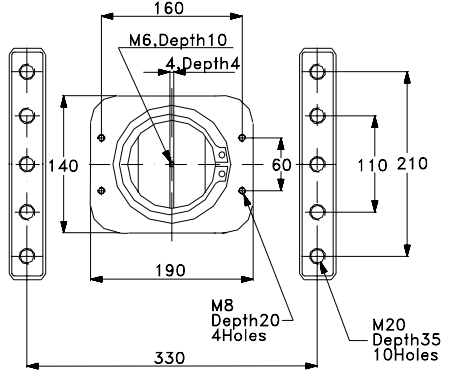

RCG-SR

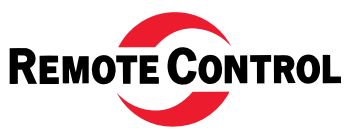
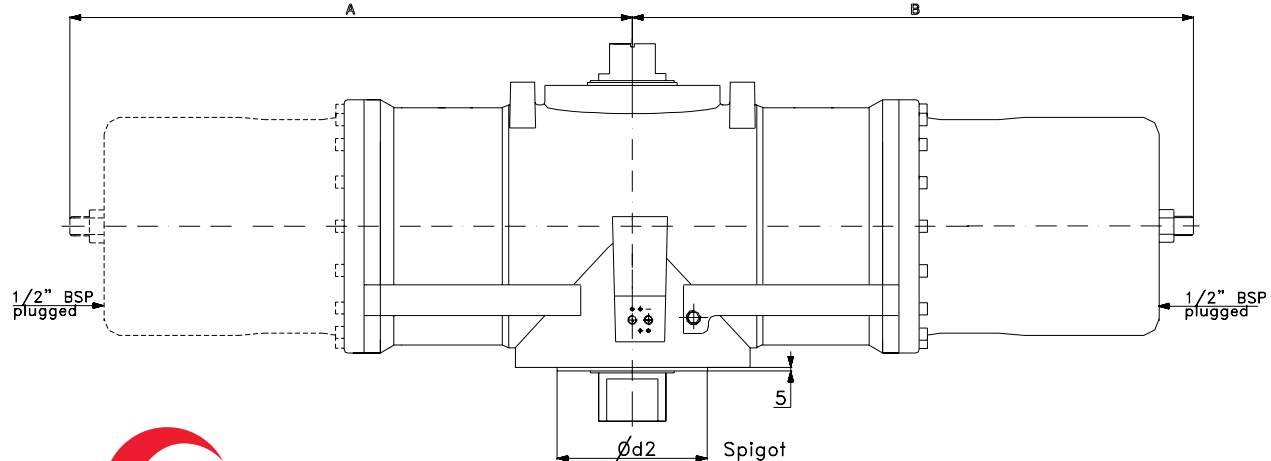

Torque Nm At existing air pressure.

DA: Double Acting Actuator.

Type	Position	2,8 bar 40 psi	3,5 bar 50 psi	4,2 bar 60 psi	4,5 bar 65 psi	5,5 bar 80 psi	6 bar 87 psi	7 bar 100 psi	8,5 bar 120 psi	10 bar 145 psi
RCG 90-DA	0°	3300	4170	5050	5500	6800	7400	8340	10400	12600
	50°	1580	2010	2440	2650	3280	3570	4020	5000	6070
	90°	2440	3100	3750	4080	5050	5500	6200	7700	9300
RCG 100-DA	0°	6760	8600	10400	11300	14000	15250	17000	21400	25900
	50°	3200	4050	4900	5380	6600	7200	8100	10000	12200
	90°	5020	6380	7700	8400	10400	11350	12750	15900	19200

SR: Spring Return Actuator. Springs adapted to air pressure.

Type	Function	Position	2,8 bar / 40 psi		3,5 bar / 50 psi		4,2 bar / 60 psi		4,5 bar / 65 psi		5,5 bar / 80 psi		6 bar / 87 psi		7 bar / 100 psi		
			Air	Spring	Air	Spring	Air	Spring	Air	Spring	Air	Spring	Air	Spring	Air	Spring	
RCG 90-SR	Air opens	0°	1920		2440		2960		3200		4000		4350		5000		
		60°	760		960		1160		1240		1560		1700		1950		
		90°	920		1160		1400		1560		1920		2100		2400		
	Spring closes	90°		1440		1840		2240		2440		3040		3300		3800	
		30°		700		880		1064		1160		1440		1550		1800	
		0°		1040		1360		1640		1760		2200		2400		2750	
RCG 100-SR	Air opens	0°	3840		4880		5920		6440		8000		8700		10000		
		60°	1540		1960		2360		2580		3200		3500		4000		
		90°	1920		2440		2960		3220		4000		4350		5000		
	Spring closes	90°		2980		3780		4600		5000		6200		6750		7750	
		30°		1440		1840		2220		2420		3000		3250		3750	
		0°		2160		2740		3340		3620		4500		4900		5620	

Measurements and weights

Measurement: mm Weight: kg

Air consumption

Litres free air at 6 bars air pressure

Type	A	B	d2(f8)	Weight	Anti clockwise rotation	Clockwise rotation
RCG 90-DA	415	520	200	280	130	305
RCG 90-SR	415	850	200	350	305	—
RCG 100-DA	520	520	230	310	260	265
RCG 100-SR	850	850	230	500	265	—

Operating times when using existing air connections: 3-60 seconds depending on the dimension of the connecting pipes, solenoid valves, etc.

RCG-DA

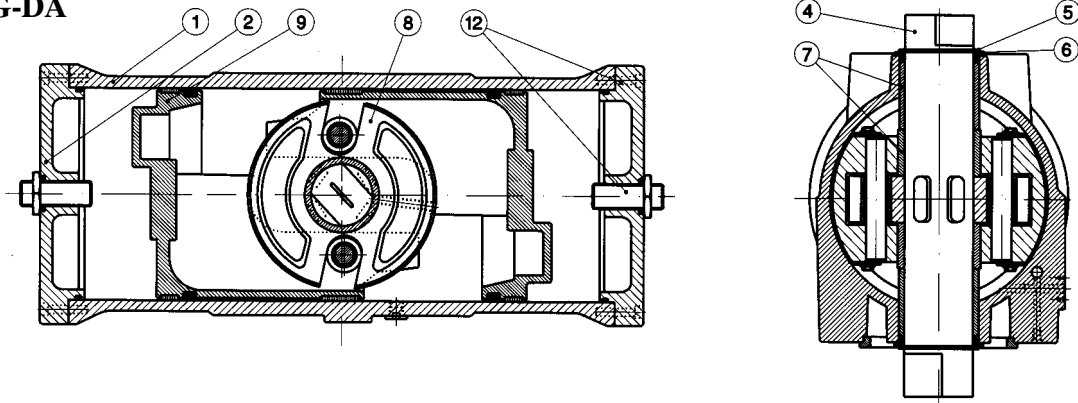

RCG-SR

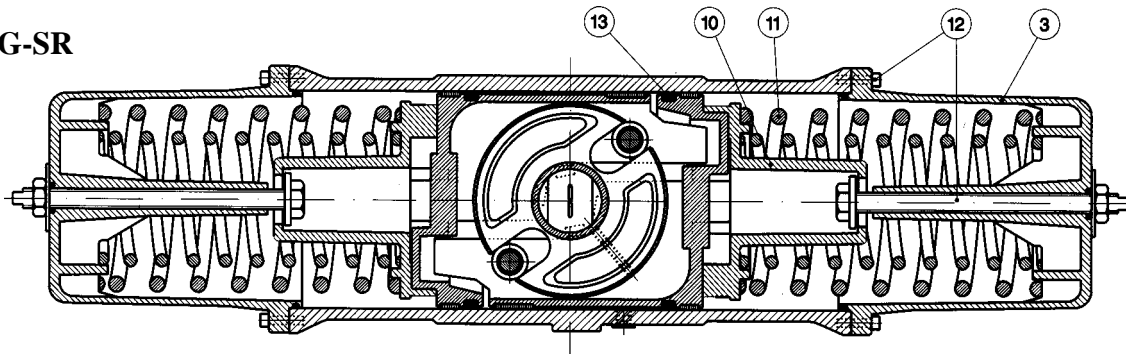

Material table for RCG90-100, DA and SR

Part No.	Description	Material	Part No.	Description	Material
1	Cylinder	Ductile iron, Epoxy coated	8	Scotch Yoke	Alloyed, forged steel
2	End plates	Steel, Epoxy coated	9	Piston	Aluminium
3	Spring housings	Ductile iron, Epoxy coated	10	Spring steering	Ductile iron, painted
4	Shaft	Carbon steel, zinc and yellow chromated <i>Option: Stainless steel</i>	11	Springs	Spring steel, painted
5	Circlips	Spring steel, Dacrolite-treated	12	Fastening and adjustment screws	Carbon steel, zinc-plated <i>Option: Stainless steel</i>
6	Thrust washers	POM (Delrin) <i>Option: Stainless steel</i>	13	O-Rings	Nitrile
7	Bearing & Support ring	POM (Delrin) <i>Option: Tin bronze</i>			

We reserve our right for modifications caused by technical development.