

A **Thermowell** is a pressure tight receptacle designed to accept a temperature sensing element and provide a means to insert that element into a vessel or pipe. It acts as a barrier between a process medium and the sensing element of a temperature measuring device and protects against corrosive process media. A thermowell also allows the sensing element to be removed from the application while maintaining a closed system. The material chosen must be compatible with the process medium to which it is exposed.

The U-length (insertion length) of a thermowell indicates its insertion depth into a process vessel or piping system and is measured from the tip of the thermowell to the underside of the threads. Lagging extension thermowells are used on applications where insulation covers the vessel or piping system. The extension length (T-length) is the measurement between the instrument connection and process connection of the thermowell.

### Standard (2 1/2" - 6")

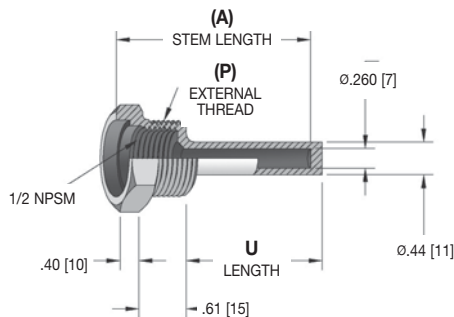

### Standard (9" - 24")

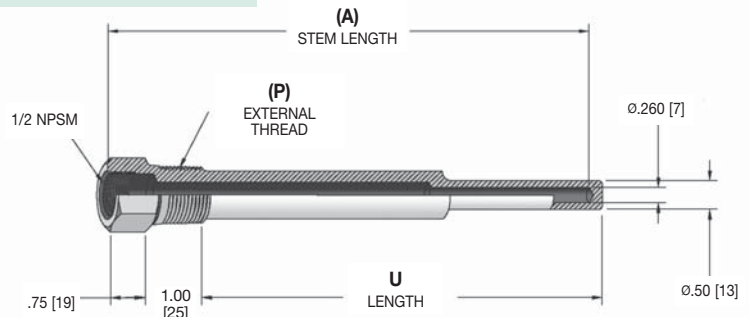

### with Lagging Extension (4" - 24")

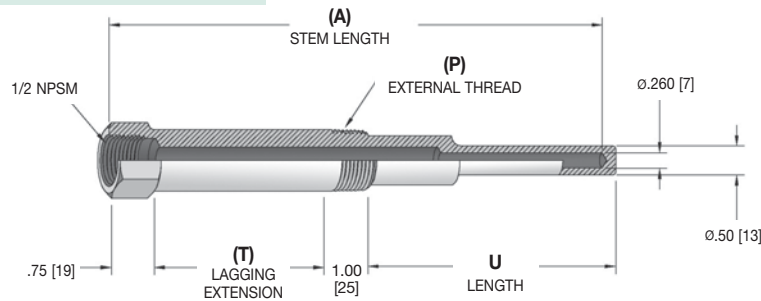

Units inches: [mm]

CONTROL VALVES

### Lengths

(A) Stem Length	Standard U Length	Lagging U Length	
		(T) Lagging Extension	
2 1/2"	1.75 [44]	—	—
4"	2.50 [64]	1.00 [25]	1.50 [38]
6"	4.50 [114]	2.00 [51]	2.50 [64]
9"	7.50 [191]	3.00 [76]	4.50 [114]
12"	10.50 [267]	3.00 [76]	7.50 [191]
15"	13.50 [343]	3.00 [76]	10.50 [267]
18"	16.50 [419]	3.00 [76]	13.50 [343]
24"	22.50 [572]	3.00 [76]	19.50 [495]

### Pressure Ratings (PSI)

Material	Operating Temperature					
	70°F	200°F	400°F	600°F	800°F	1000°F
Carbon steel	5000	5000	4800	4600	3500	-
304 stainless steel	6550	6000	4860	4140	3510	3130
316 stainless steel	6540	6400	6000	5270	5180	4660

### How to Order 76-Series Thermowells

Example Model Code: **76-4JN6**

Thermowell Model	(P) External Thread	(A) Stem Length	(T) Lagging Extension	Material
76 Thermowell	3 1/2 NPT*	D 21 1/2" Stem	A 1" Extension (4" Stem only)	2 Brass
	4 3/4 NPT	G 4" Stem	C 2" Extension (6" Stem only)	5 304SS
	5 1 NPT*	J 6" Stem	E 3" Extension (9" thru 24" Stem only)	6 316SS
		M 9" Stem	N No Extension	
		R 12" Stem		
		V 15" Stem		
		Wa 18" Stem Wk 24" Stem		

\*Not available with 2 1/2" Stem Length

Other thermowell styles available. Please consult factory.