



USER INSTRUCTIONS

Automax WS/WM Ultraswitch™
Switchbox

Installation
Operation
Maintenance

FCD AXENIM0135-02 - 09/16



CONTENTS

1. GENERAL INFORMATION	3
2. SAFETY INSTRUCTION	3
3. UNPACKING	3
4. CERTIFICATES	4
5. SPECIFICATIONS	4
5.1 Technical data	4
5.2 Materials of construction	4
5.3 Product label.....	4
5.4 WS/WM UltraSwitch™ nomenclature.....	5
5.5 WS/WM UltraSwitch™ switch options	6
6. INSTALLATION	8
6.1 Wiring instructions	9
6.2 Cover and housing options	10
7. SWITCHES (Certified)	11
7.1 Installation in hazardous locations.....	11
7.2 Adjusting limit switches	11
7.3 Cam fine adjustment	11
7.4 Switch option specifications (all)	12
8. DIMENSIONS	14
9. SPARE PARTS	15
10. SPECIAL CONDITIONS FOR SAFE USE	15

1. GENERAL INFORMATION

WS/WM Ultraswitch™ enclosures provide local and remote position indication for automated valves. They generally feature a visual black/yellow or red/green indicator for intuitive local position determination. The WS/WM Ultraswitch™ is available with a number of limit switch options for remote indication, in a variety of electrical applications. They may also be used as a junction box for direct installation of solenoid valves.

2. SAFETY INSTRUCTION

Read the safety instructions in this manual carefully before using the product. If any questions arise during installation, contact supplier/sales office before continuing further.

This equipment is suitable for use in Class 1, Division 1&2, groups ABCDFG or non-hazardous locations only.

3. UNPACKING

Report transport damage to the carrier immediately. In case of discrepancies - contact your nearest FLOWSERVE location.



- Substitution of components may impair suitability for Div. 2 locations.
- Inspect periodically for degradation. Replace parts if degradation is found.
- Cleaning this housing by rubbing should be done in a non-hazardous area.
- Potential electrostatic charging hazard, clean only with a damp cloth – danger of propagating discharge.
- All grounding and bonding installation requirements must be addressed.
- Pay attention to personal protection, (clothing, glasses, gloves) when performing installation or service.
- All installation, inspection, and maintenance of the equipment should be performed by suitably trained personnel. For more information refer to EN 60079-14:1997, EN 60079-17, EN 60079-18, EN 60079-19.
- Do not disconnect equipment unless area is known to be non-hazardous.
- To prevent ignition of flammable or combustible atmospheres, disconnect power before servicing.
- Use only Flowserve original spare parts in order not to invalidate certification.

WARNING

POTENTIAL ELECTROSTATIC HAZARD

DO NOT OPEN WHEN AN EXPLOSIVE ATMOSPHERE MAY BE PRESENT

CABLE ENTRANCES MAY REACH A TEMPERATURE OF MAX 83 °C

SEE MANUAL FOR SAFE USE

**CERTIFICATES, MANUAL AND CONTROL DRAWING CAN BE DOWNLOADED FROM
WWW.PMV.NU**

4. CERTIFICATES

General Purpose

ATEX II 1GD Ex ia IIC T4/T5/T6

ATEX II 1GD Ex ia IIB T4/T5/T6

cCSAus Class I, Division 1 Groups A,B,C,D; Class II Division 1 Groups F,G; Class III

cCSAus Class I, Division 2, Groups A,B,C,D; Class II, Division 2, Groups F,G; Class III

5. SPECIFICATIONS

5.1 Technical data

Ingress protection

IEC 529 IP 66/67, NEMA Type 4X

Weight (max) 0.7 kg / 1.55 lbs

5.2 Materials of construction

Part

Housings

Material

Powder Epoxy painted Aluminum or PA6/PA66 engineered resin, 25 – 30% fiberglass filled

Covers

Powder Epoxy painted Aluminum or PA6/PA66 engineered resin, 25 – 30% fiberglass filled or Transparent Polycarbonate

Shaft

Stainless Steel SS EN 2346 / AISI 303

Cams/Splines

Nylon

Terminal Block

Nylon

Internal Brackets

Nylon, Aluminum or Stainless Steel

All Internal Fasteners

Stainless Steel

All External Fasteners

Stainless Steel

All Molded in Fasteners

Anodized Aluminum

Indicators

Polycarbonate or PA66

5.3 Product label



* NOTE: If the equipment is likely to come in contact with aggressive substances, it is the responsibility of the user to take suitable precautions to prevent it from being adversely affected, thus ensuring that the type of protection provided by the equipment is not compromised.

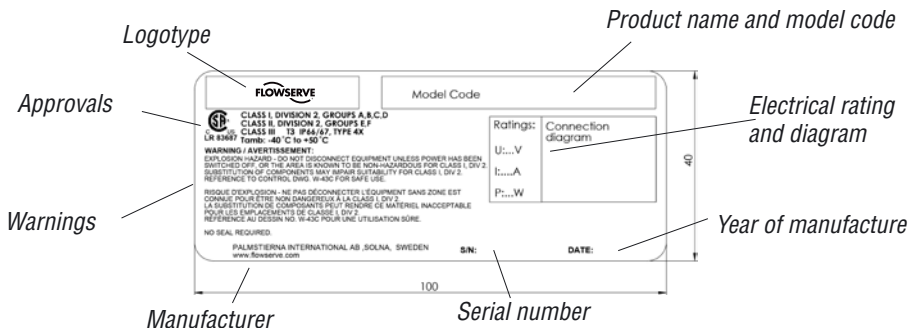

5.4 WS/WM UltraSwitch™ nomenclature

- A = Brand sticker**
 X Automax
- B = Shaft type**
 N Namur shaft, EN 15714
 S Low profile shaft
 T For NAF Turnex
 D Double "D" 1/4 Inch Flats
- C = Body style**
 WS General Purpose/I.S. Enclosure / 1/2" NPT Conduit entries
 WM General Purpose/I.S. Enclosure / M20x1,5mm Conduit entries
- D = Number of conduit entries**
 2 2 conduit entries
 4 4 conduit entries (2 according to "C" + entries opposite side with different type of th-reading)
- E = Body material**
 A Aluminum
 R Engineered resin
- F = Cover material**
 A Aluminum
 R Engineered resin
 P Polycarbonate Cover (clear)
- G = Indicator**
 1 No indicator
 2 Flat Arrow Indicator Yellow / Black
 H Black / Yellow UltraDome™
 U Standard UltraDome™ (Red Close/Green Open)
- H = Number of switch elements**
 0 No switches (empty housing)
 1 1 Switch
 2 2 Switches
- I = Switch type - (See page 12 and 13)**
- J = Certificate**
 14 General Purpose
 15 ATEX Ex ia
 28 cCSAus Ni

Ordering code example

A	B	C	C	D	E	F	G	H	I	I	J	J
X	N	W	S	2	A	R	U	2	P	P	2	8

A = brand, NAMUR shaft, 1/2" NPT Housing with 2 conduits, Aluminum body, Resin cover, standard UltraDome™, 2 proximity switches "PP", cCSAus certificate (2 open terminals)

5.5 WS/WM UltraSwitch™ switch options

Cert.	Switch Option	Manufacturer	Load Capacity	
M1	SPDT Mechanical	Honeywell MicroSwitch	15A @ 125/250 VAC; 0.5A @ 125 VDC; 0.25A @ 250VDC; 5A @ 120VAC (resistive load)	
MG	A, B	SPDT Gold Mechanical	Honeywell MicroSwitch	1A @ 125 VAC; 50 mA @ 24 VDC (resistive load)
F1	IN5129	IFM	10-36VDC	
F3	IF5250	IFM	10-36VDC NC PNP, 150mA, 3-wire NC	
F5	IF6001	IFM	18-32VDC, NO PNP, 150mA@50°C	
F6	IF6034	IFM	10-36VDC, NO PNP, 150mA, Stainless steel	
F7	IN0074	IFM	20-250 AC/DC NO, 350mA/100mA	
F8	IN0081	IFM	20-250 AC/DC NO, 350mA/100mA w/LED	
FJ	IN5263	IFM	IN-2002-FRKG/PH RT	
P4	A, B, C	SPST Proximity	Aleph	0.35A @ 140 VAC; 0.25A @ 200VDC (50 W Max.)
P5	A, B, C	SPDT Proximity	Hamlin	0.25A @ 120 VAC; 0.25A @ 28 VDC (3 W Max.)
PE	A, B, C	SPDT Sabre Proximity	Flowserve	1A @ 120 VAC; 1A @ 24 VDC
PP	C	SPDT Phazer Proximity	Flowserve	3A @ 120 VAC; 2A @ 24 VDC
PT	A, B, C	SPST BRS Proximity	Flowserve	3A @ 120 VAC; 0.5 @ 24 VDC
N8	A	Solid State Proximity	PF NJ2 V3 N	NAMUR NC Sensor; 8 VDC
NP	A	Solid State Proximity	PF SJ3.5-N	NAMUR Sensor Output; 5-25 VDC Supply
NQ	A	Solid State Proximity	PF NJ4-12GK-N	NAMUR NC Sensor; 8 VDC
NR		Solid State Proximity	PF NJ4-12GM40-E1	PNP Sinking; 200 mA max. Current; 10-60 VDC
NS		Solid State Proximity	PF NJ4-12GM40-E2	NPN Sourcing; 200 mA max. Current; 10-60 VDC
NT		Solid State Proximity	PF NJ4-12GK40-E2	NPN Sourcing; 200 mA max. Current; 10-60 VDC
N9		Solid State Proximity	PF NBB3-V3-Z4	NPN Sourcing; 100 mA max. Current; 5-60 VDC
NW	A	Solid State Proximity	PF SJ3.5-SN	NAMUR NC Sensor; 8 VDC

More switch options available

Code	Certificate
A	ATEX II 1GD Ex ia IIC T4/T5/T6 ATEX II 1GD Ex ia IIB T4/T5/T6
B	cCSAus IS
C	cCSAus NI

Notes

- 1) Valid certification codes according to table in WS/MM Nomenclature on page 5.
- 2) Some models have more than two open terminal locations open as standard. Consult factory for details.

6. INSTALLATION

The WS/WM Ultraswitch™ may be installed to valves or valve actuators with a variety of mounting hardware.

For best results, specify the NAMUR shaft option and NAMUR mounting hardware when fitting to a NAMUR compliant actuator. These options allow direct coupling to actuators without couplings, reducing dead band.

Bolt bracket to actuator and WS/WM Ultraswitch™ to bracket, leaving bolts finger tight.

For NAMUR applications the WS/WM Ultraswitch™ switch shaft features an integral alignment pin. This pin must engage the tapped hole in the actuator shaft.

For non-NAMUR applications, make sure to properly install a coupler between the WS/WM Ultraswitch™ and actuator. Once the WS/WM Ultraswitch™ is installed with fasteners loosely tightened, stroke the actuator two or three times to align the bracket. Then tighten all fasteners.

Ambient temperature working conditions.
The WS/WM Ultraswitch™ switch box is tested and operational in following temperature range:

- 40° – 180°F
- 40° – 80°C

Mounting kits

For compact/low profile installation - use mounting kit KL01 or KL02. Use with shaft type "S" only. These kits allow the user to install it on actuators with a shaft height of 20, 30 or 50mm. The kits also adapt easily to both 80/30mm actuator top pattern as well as 130/80mm actuator top pattern (see table below for reference). Standard NAMUR mounting brackets are also available.

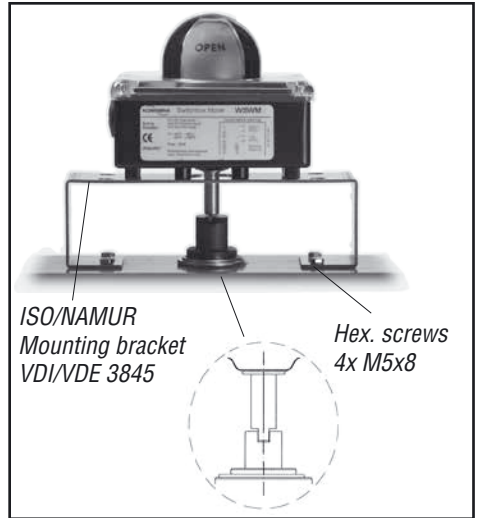

WS/WM switch mounted on rotary actuator

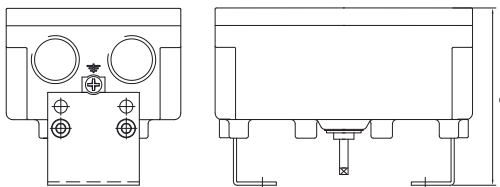

Note! Shaft type "S" only!

Mounting kit p/n	Actuator shaft height (mm)	Bolt pattern 80/30 (mm)	Bolt pattern 130/30 (mm)	C = Height (mm)
KL01	20/30	yes	yes	80/90
KL02	50	yes	yes	110

6.1 Wiring instructions



- Perform all wiring according to the wiring diagram found on the label in the housing (see picture) and instructions given below.
- Make sure that the ground wire is correctly connected
- Seal unused entries with proper and suitable conduit plugs.

The WS/WM UltraSwitch™ enclosures feature pre-wired switches. All user connections are made at a numbered terminal strip. Both external and internal grounding locations have been provided for use in installation. A wiring diagram is located on the product label and indicates which terminal number corresponds to which switch contact: normally open, normally closed, common, etc. Follow the wiring diagram, and electric code to connect switches to your system.

For field wiring: ensure that any excess wire lengths or loops are routed away from any moving parts and are short enough, or secured to ensure a 1/4" clearance between the wire and the inside surface of the switchbox cover.

Note: for all magnetically tripped proximity switches, the top switch should only be used to indicate the clockwise position: the bottom switch should only be used to indicate the counter-clockwise position. Any deviation from these settings may result in erratic indication.

Solenoids may also be wired through the WS/WM UltraSwitch™ enclosure. At least two auxiliary terminals are included as standard. Wire the solenoid to auxiliary terminals, then connect power leads to the opposite terminal side. Be sure to properly ground the solenoid at the provided ground terminal.

WS UltraSwitch™ Series enclosures include two 1/2" NPT conduit entries and the WM Series includes two M20x1.5 conduit entries.

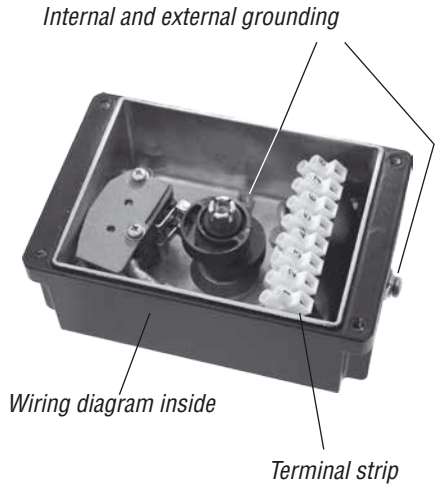

Caution!

- Proper and suitable conduit plugs must be installed in unused conduit entries before putting the unit into service.
- Installation must be according to National Electric Code, local codes, local certificates and manufacturer's instructions in all cases. Environmental seals must be used to protect ingress of water through the conduits.
- Prevent electrostatic build-up for safe use. The enclosure of the WS/WM UltraSwitch™ switch box is made of PA6/PA66 and any impact or friction caused by external objects should be avoided to prevent electrostatic build-up.



6.2 Cover and housing options



Aluminum or Resin
cover
Dome Indicator



Aluminum or Resin
cover flat



Aluminum or Resin
cover
Arrow Indicator



Polycarbonate transparent cover
Dome Indicator



Polycarbonate transparent cover
Arrow Indicator



Aluminum housing



Resin housing

7. Switches (certified)



Substitution of components may impair suitability for hazardous (classified) locations. Do not disconnect equipment unless area is known to be non-hazardous.

To prevent ignition of flammable or combustible atmospheres, disconnect power before servicing, or; read, understand and adhere to the manufacturer's live maintenance procedures.

7.1 Installation in hazardous locations

Refer to control drawing RA-2. Consult factory.

7.2 Adjusting limit switches

UltraSwitch™ enclosures feature Quick-Set™ cams which are used to trip the limit switches. These cams are easily adjusted without tools.

Caution: disconnect power before removing cover when installed in hazardous locations.

Remove cover and set aside. Rotate actuator/valve to full clockwise (CW) position. Adjust cam(s) associated with CW as follows:

1. Push or pull cam against spring to disengage it from splines.
2. Rotate cam CW breaking contact with switch (or moving magnet away from switch).
3. Continue rotating cam CW just until switch trips.
4. Release cam and re-engage it with splines.

Rotate actuator/valve to full counter-clockwise (CCW) position. Adjust cam(s) associated with CCW as described in steps 1 through 4, except

7.3 Cam fine adjustment

Some cams have a fine adjustment available. These cams will have a small screw embedded in the side of the cam.

Adjusting this screw clockwise or counter clockwise will deform the cam, changing the trip point slightly.

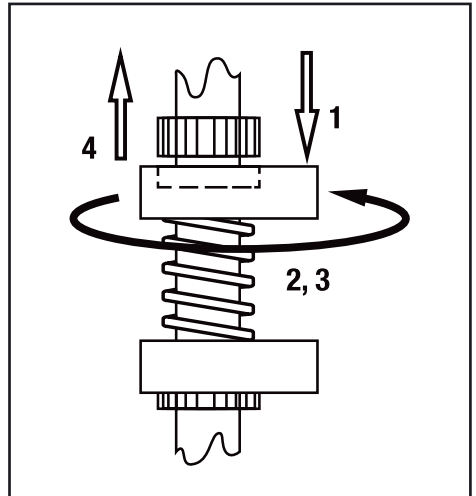

Cam adjustment

rotate cam(s) CCW.



Note: factory setting is:
Top switch = CW (closed)
Second switch = CCW (open)



Cam fine adjustment

7.5 Switch option specifications (all)

Code	Switch Option	Manufacturer	Part Number	Load Capacity
00	No switches (empty housing)			
F1		IFM	IN5129	10-36VDC (J=14only)
F3		IFM	IF5250	10-36VDC NC PNP, 150mA, 3-wire NC
F5		IFM	IF6001	18-32VDC, NO PNP, 150mA@50°C
F6		IFM	IF6034	10-36VDC, NO PNP, 150mA, Stainless Steel
F7		IFM	IN0074	20-250 AC/DC NO, 350mA/100mA
F8		IFM	IN0081	20-250 AC/DC NO, 350mA/100mA w/LED (J=14)
F9		IFM	IN0097	20-250 AC/DC NO FB
	IFM	IF5249	10-36VDC NO PNP,	150mA, 3-wire NO
FC		IFM	IF5718	10-36VDC NO PNP/NPN, 150mA, plastic
FE		IFM	NS5003	IS-2002-N
FG		IFM	IS5070	FB3004-APKG
FH		IFM	IS5001	IS-3002-BPOG
FJ		IFM	IN5263	IN-2002-FRKG/PH RT
FK		IFM	NS5002	IS-2002-N
FZ	AS-i Bus Card			31VDC 28 mA
M1	SPDT Mechanical	Honeywell MicroSwitch	V7-1C13D8-201	15.1A (1/2 HP) at 125/250 VAC; 1/4A at 125 VDC; 1/4A at 250 VDC; 5A at 120 VAC (resistive load)
MG	SPDT Gold Mechanical	Honeywell MicroSwitch	V7-1D19D8-201	1A at 125 VAC / 50 mA at 24 VDC (resistive load)
N1		Pepperl+Fuchs	NJ4-12GM40-E	
N2		Pepperl+Fuchs	NJ2-12GK-N	
N3		Pepperl+Fuchs	SJ3,5-S1N	
N4		Pepperl+Fuchs	NJ2-12GK-SN	
N5		Pepperl+Fuchs	NJ4-12GK40-E	
N6		Pepperl+Fuchs	NJ4-12GK40-E1	
N7		Pepperl+Fuchs	NBB2-V3-E0	
N8	Solid State Proximity	Pepperl+Fuchs	NJ2-V3-N	NAMUR Sensor Output / 5-25 VDC Supply
N9	Solid State Proximity	Pepperl+Fuchs	NBB3-V3-Z4	NPN Sourcing/ 100 mA max. Current / 5-60 VDC
NA		Pepperl+Fuchs	NBN4-12GM40-E2	
NB		Pepperl+Fuchs	NJ2-12GM-N	
NC		Pepperl+Fuchs	NJ4-12GM-N	
ND		Pepperl+Fuchs	NCB2-12GM40-Z1	
NE		Pepperl+Fuchs	NCB2-12GM35-NO	
NF		Pepperl+Fuchs	NCN4-12GM35-NO	
NG		Pepperl+Fuchs	NJ5-11-N-G	
NH		Pepperl+Fuchs	NCB4-12GM40-NO	
NK		Pepperl+Fuchs	NCN4-12GM40-Z0	
NL		Pepperl+Fuchs	NCB2-V3-NO	
NM		Pepperl+Fuchs	NJ2-11-SN-G	
NN		Pepperl+Fuchs	NBB2-V3-E2	
NP	Solid State Proximity	Pepperl+Fuchs	SJ3.5-N	
NQ	Solid State Proximity	Pepperl+Fuchs	NJ4-12GK-N	
NR	Solid State Proximity	Pepperl+Fuchs	NJ4-12GM40-E1	PNP Sinking / 200 mA max. Current / 10-60 VDC

7.5 Switch option specifications (continued)

Code	Switch Option	Manufacturer	Part Number	Load Capacity
NS	Solid State Proximity	Pepperl+Fuchs	NJ4-12GM40-E2	NPN Sourcing / 200 mA max. Current / 10-60 VDC
NT	Solid State Proximity	Pepperl+Fuchs	NJ4-12GK40-E2	NPN Sourcing / 200 mA max. Current / 10-60 VDC
NV	Solid State Proximity	Pepperl+Fuchs	NJ2-11-N-G	NAMUR Sensor Output / 5-25 VDC Supply
NW	Solid State Proximity	Pepperl+Fuchs	SJ3,5-SN	NAMUR Sensor Output / 5-25 VDC Supply
NX			NBB2-V3-E3	
NY	Solid State Proximity	Pepperl+Fuchs	NJ4-12GK-SN	NAMUR Sensor Output / 5-25 VDC Supply
P4	SPST Proximity	Aleph	PS-6132	0.35A at 140 VAC / .25A at 200VDC (50 W Max.)
P5	SPDT Proximity	Hamlin	59135-030	0.25A at 120 VAC / 0.25A at 28 VDC (3 W Max.)
PE	SPDT Sabre Pxy	Flowserve	XA0199	1A at 120 VAC / 1A at 24 VDC
PP	SPDT Phazer Pxy	Flowserve	XA0155	3A at 120 VAC / 2A at 24 VDC
PT	SPST BRS Pxy	Flowserve	XA0157	3A at 120 VAC / 0.5 at 24 VDC
R1		Pepperl+Fuchs	NBB3-V3-Z4-3G-3D	
R2		Pepperl+Fuchs	NBB2-V3-E3-3G-3D	
R3		Pepperl+Fuchs	NBN4-V3-E2-3G-3D	

8. Dimensions

WS body enclosure

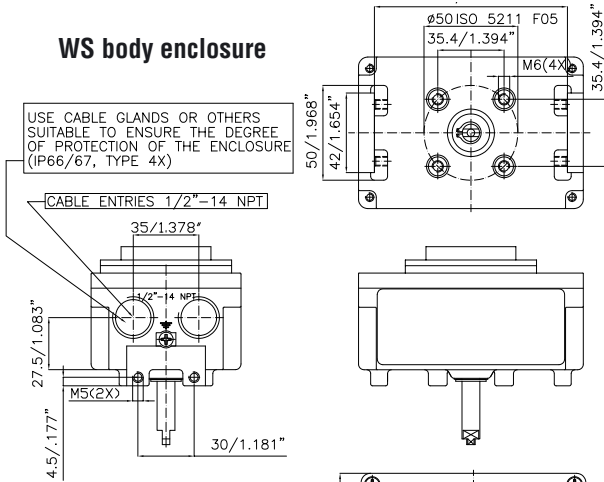

WM body enclosure

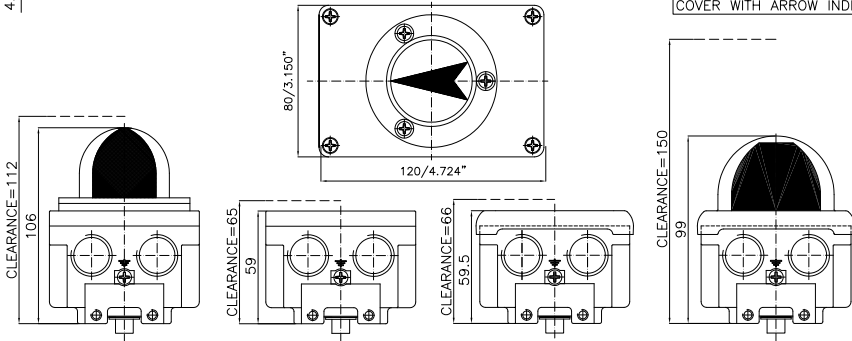
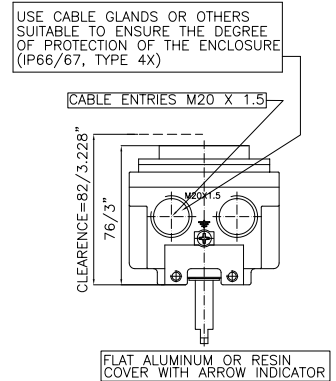

PHAROS ALUMINUM OR RESIN COVER WITH ARROW INDICATOR

FLAT ALUMINUM OR RESIN COVER WITHOUT INDICATOR

FLAT TRANSPARENT PC COVER WITH ARROW INDICATOR

PHAROS TRANSPARENT PC COVER WITH DOME INDICATOR

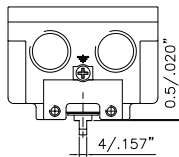

LOW PROFILE SHAFT

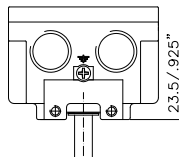

NAMUR SHAFT EN15714

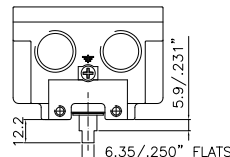

DOUBLE "D" SHAFT

9. Spare parts

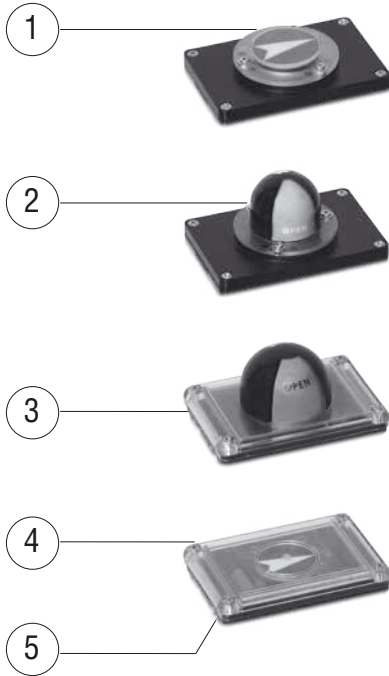

Pos	Part No	Description
1	D2-SP31	Arrow indicator assembly
2	D2-SP52	Dome indicator assembly red/green
2	D2-SP17	Dome indicator assembly black/yellow
3	M800214	Polycarbonate transparent cover with dome indicator red/green
4	M800215	Polycarbonate transparent cover with arrow indicator
5	ME1967	Gasket for cover (all cover types)

10. Special Conditions for Safe Use

- The Rotary Limit Switch Box is marked with the following warning marking: "WARNING – POTENTIAL ELECTROSTATIC CHARGING HAZARD – SEE INSTRUCTIONS".
- Enclosure material limits for EPL Ga are exceeded, as aluminium content is greater than 10%. User must determine the suitability of the equipment for the particular application, for example, to avoid an ignition hazard due to impact or friction
- The total electrical ratings must not exceed the values indicated in the control drawing, W-43C.



Flowserve Corporation
Flow Control Division
1978 Foreman Drive
Cookeville, Tennessee 38501 USA
Phone: +931 432 4021
Fax: +931 432 5518

Flowserve Flow Control (UK) Ltd.
44 Victoria Way, Burgess Hill
West Sussex, RH15 9NF
UNITED KINGDOM
Tel: +44 (0) 1444 884846
E-mail: pmvuksales@flowserve.com

Flowserve Flow Control Benelux
Rechtzaad 17
4703 RC Roosendaal
THE NETHERLANDS
Tel: +31 (0) 30 6771946
Fax: +27 (0) 30 6772471
E-mail: fcbinfo@flowserve.com

Flowserve Flow Control GmbH
Rudolf-Plank Strasse 2
D-76275 Ettlingen
GERMANY
Tel: +49 (0) 7243 103 0
Fax: +49 (0) 7243 103 222
E-mail: argus@flowserve.com

Flowserve Spa
Via Prealpi, 30
20032 Cormano (Milano)
ITALY
Tel: +39 (0) 2 663 251
Fax: +39 (0) 2 615 18 63
E-mail: infoitaly@flowserve.com

Flowserve Ahaus GmbH
von-Braun-Str. 19a
48683 Ahaus
Phone: +49 2561 686-119
Fax: +49 2561 686-109

Flowserve Corporation
No. 35, Baiyu Road
Suzhou Industrial Park
Suzhou 215021, Jiangsu Province,
PRC
Phone: +86-512-6288-1688
Fax: +86-512-6288-8737

Flowserve Australia Pty Ltd
Flow Control Division
14 Dalmore Drive
Scoresby, Victoria 3179
Australia
Phone: +61 3 9759 3300
Fax: +61 3 9759 3301

Flowserve Pte Ltd
No. 12 Tuas Avenue 20
Singapore 638824
Phone: +65 6879 8900
Fax: +65 6862 4940

Flowserve do Brasil Ltda
Rua Tocantins, 128 - Bairro Nova
Gerti
São Caetano do Sul,
São Paulo 09580-130 Brazil
Phone: +5511 4231 6300
Fax: +5511 4231 6329 - 423

flowserve.com

To find your local Flowserve representative:

To find your local Flowserve representative please use the Sales Support Locator System found at www.flowserve.com

FCD AXENIM0135-02 - 09/16

Flowserve Corporation has established industry leadership in the design and manufacture of its products. When properly selected, this Flowserve product is designed to perform its intended function safely during its useful life. However, the purchaser or user of Flowserve products should be aware that Flowserve products might be used in numerous applications under a wide variety of industrial service conditions. Although Flowserve can provide general guidelines, it cannot provide specific data and warnings for all possible applications. The purchaser/user must therefore assume the ultimate responsibility for the proper sizing and selection, installation, operation, and maintenance of Flowserve products. The purchaser/user should read and understand the (WS/WM Switchbox User Instructions) instructions included with the product, and train its employees and contractors in the safe use of Flowserve products in connection with the specific application.

While the information and specifications contained in this literature are believed to be accurate, they are supplied for informative purposes only and should not be considered certified or as a guarantee of satisfactory results by reliance thereon. Nothing contained herein is to be construed as a warranty or guarantee, express or implied, regarding any matter with respect to this product. Because Flowserve is continually improving and upgrading its product design, the specifications, dimensions and information contained herein are subject to change without notice. Should any question arise concerning these provisions, the purchaser/user should contact Flowserve Corporation at any one of its worldwide operations or offices.

For more information about Flowserve Corporation, contact www.flowserve.com or call USA 1-800-225-6989.

© October 2013, Flowserve Corporation, Irving, Texas