

ARF200

Paperless Recorder Advanced Recorder

Overview

The ARF200 Paperless Recorder adopts a highly visible 12.1-inch TFT color LCD, incorporates advanced functions, is easy to use, and is network-compatible.

A sampling rate of 100 ms for all 48 points^{*1} and a precision of $\pm 0.1\%$ are achieved, and measured data can be stored in internal memory or on a memory card (CF or compact flash and USB memory).

Network compatibility enables monitoring in a Web browser running on PCs on the network. Data files can also be sent by FTP transfer and notifications can also be sent by e-mail.

Features

- **Clear 12.1-inch TFT color LCD** The highly visible large display used has a wide range of built-in display functions.

You can choose from realtime/historical trend display, bar graph display and numeric display according to your specific requirements.

- **Large data memory and various recording modes**

A CF (Compact Flash) card slot and USB port are provided as standard as external memory. This allows large amounts of data to be recorded and saved. Various data save modes can be selected such as schedule recording based on day of week/time and date/time and recording of data before and after trigger points (e.g. alarms).

Data can be saved in CSV or binary format to suit your specific requirements.

*1: Supported in input measurement 100ms specifications



- **Improved operability by use of touch panel**

Use of a touch panel and exclusive keys for each function keeps operation simple and does away with the need for a manual.

The trend screen can be scrolled by touch operation, and comments can be written on screens with the touch pen (provided).

- **LAN environment network compatibility**

Ethernet is supported as standard, which allows remote monitoring on a browser, FTP client/server transactions, e-mail notifications and various other applications.

Network Instrumentation Module (Ethernet) communications option (scheduled for sale soon) also enables data from the Network Instrumentation Module to be recorded, number of recording points to be expanded and remote measurement to be performed.

Function block diagram

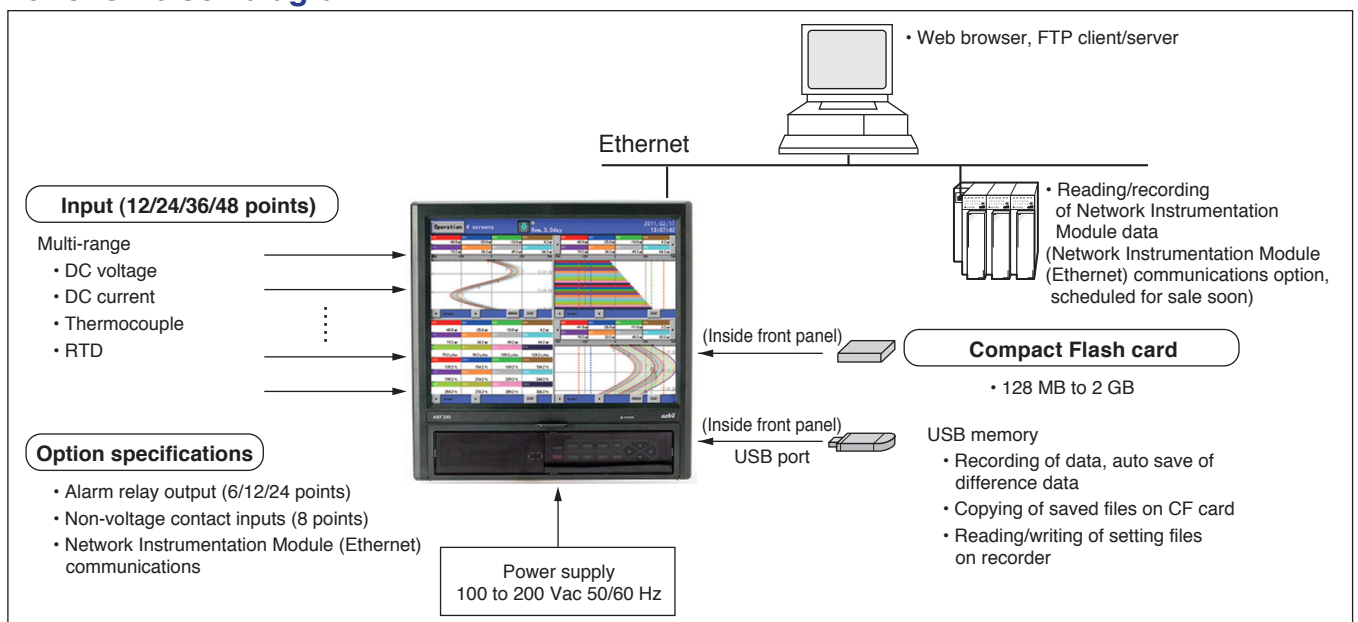

Specifications

Input specifications	Input type	DC voltage/DC current/thermocouple/RTD (See Table 1. Input type/Range/Display accuracy.) * DC current input is supported by adding an external reception resistor.
	Number of input channels	12, 24, 36, 48
	Input measurement cycle	Approx. 100ms/all points, 1s specifications: approx. 300 ms/all points
	Allowable signal source resistance	Thermocouple input (burnout disabled)/DC voltage input (± 2 V or less): 1k Ω or less DC voltage input (± 5 V to ± 50 V): 100 Ω or less RTD: 10 Ω or less per wire (must be equal on all 3 wires)
	Input resistance	DC voltage, thermocouple input: approx. 1 M Ω
	Maximum input voltage	DC voltage input (± 2 V or less)/Thermocouple input (burnout disabled): ± 10 Vdc max DC current input (± 5 V to ± 50 V): ± 60 Vdc max Thermocouple input (burnout enabled)/RTD input: ± 6 Vdc max
	Insulation withstand voltage across channels	1000Vac or more across each channel (high withstand voltage semiconductor relay used)
	Burnout	Signal disconnection detection for thermocouple and RTD inputs. Upscale burnout, downscale burnout or burnout indication disabled can be selected for each input.
	Scaling	Any range/scale at DC voltage/current input
	Digital filter	FIR filter set for each point (common all points)
	Accuracy rating	(See Table 1. Input type/Accuracy rating.)
	Reference junction compensation accuracy	K, E, J, T, N, Platinel II: ± 0.5 $^{\circ}$ C max. R, S, W-WRe26, WRe5-WRe26, NiMo-Ni, CR-AuFe, U, L: ± 1.0 $^{\circ}$ C max.
Display specifications	Display	12.1-inch TFT color LCD
	Display type	Measurement data display (trend display, numerical value display, bar graph display) Historical trend display (can be displayed simultaneously with realtime trends) Information display (alarm display, marker list, file list) Setting screen (alarms, operations, memory, system, maintenance, communication, etc.)
	Trend display	Display colors: 48 (selectable) Number of screens: 6 (6 groups) Number of display points: max. 56 per screen Time axis direction: Vertical or horizontal Line thickness: 1 to 5 dots (selectable) Scale display: 4 scale Direct tag/numerical value display Can be enabled or disabled. Marker display
	Data numerical value display	Number of screens: 6 (6 groups) Number of display points: max. 56 per screen Display details: Measured values, channels/tags, units, alarm states
	Bar graph display	Number of screens: 6 (6 groups) Number of display points: max. 56 per screen Display details: Measured values, channels/tags, units, alarm states
	Information display	Alarm display (alarm generation/cancellation history display) Marker list File list
	LCD backlight	Auto/manual OFF function Brightness Adjustable in four steps Half-life of backlight brightness is approx. 5 years when used at default brightness level "3" (default) of the 4 brightness levels. To replace the LCD backlight, the recorder must be sent back to the factory for repair.
Recording specifications	Internal memory	Flash memory (capacity: 8 MB)
	External memory	CF (Compact Flash) card (capacity: 128 MB to 2 GB)
	Recording cycle	100, 200, 500 ms 1, 2, 3, 5, 10, 15, 20, 30 s 1, 2, 3, 5, 10, 15, 20, 30, 60 min
	Number of recorded files	250/number of groups used
	Recorded data	Measurement data: File name (group name), recording start date/time, tag, measurement data, alarm status/type, marker text, setting parameters
	Save format	Binary Note 1)/CSV format (can be selected for each group) Note 1) To handle binary format data on a PC, the separate data analysis tool (ARF990DA0000) is required.
	Save method	Manual start/stop (exclusive key, touch panel operation, schedule (day of week/time, date/time can be set) Trigger signal (alarm event, contact input) * Pre-trigger can be selected (number of measurements: max. 950 data)

Computation specifications	Number of operations	Max. 128	
	Operation type	<p>Arithmetic operations: Addition, subtraction, multiplication, division, power</p> <p>Comparison operations: Equal to, not equal to, larger than, smaller than, equal to or greater than, equal to or smaller than</p> <p>Logical operations: AND, OR, exclusive OR, NOT</p> <p>General functions: Round up to nearest integer past decimal point, discard digit past decimal point, absolute value square root, power of e, natural logarithm, common logarithm</p> <p>Integration operations: Analog integration, digital integration</p> <p>Channel data operations: Operations on measurement data, operations on operation results, moving average, past data, primary lag filter</p>	
Alarm functions	Number of settings	Max. 4 can be set for each point	
	Alarm types	Upper limit, lower limit, diff. upper limit, diff. lower limit (dead band can be set), error data	
	Alarm ON delay	Delay time setting range 1 to 3600 s	
	Alarm setting	AND/OR can be set.	
	Alarm output	See Option specifications.	
Communication specifications	Network	Medium	Ethernet (10BASE-T/100BASE-TX)
		FTP server	Data files are read from a computer on the network.
		FTP client	Data files are manually or automatically transferred to the server PC (FTP server) on the network.
		Web server	HTTP1.0 compliant: Display, alarm, maintenance information, etc. are displayed on the browser software (Internet Explorer5.0 or later, NetScape6.0 or later, Opera7.0 or later). * User passwords can be set.
	E-mail	Mail notification at specified times when an alarm is set Can be selected from specified time notification data or all registered data. Notified address: Max. 8 addresses	
USB communication	USB standard	Medium: USB2.0 (full speed), host function USB memory can be used as external memory. * Operation of all USB memories is not guaranteed.	
Setting/operation specifications	Operation key types	HOME, MENU, DISP, MARKER, SCROLL, CURSOR, START, STOP, up/down/left/right keys, ENTER, ESC	
	HOME setting	Easy recording setting: Input common to all data Parameter batch setting, recording cycle, selection setting	
	MENU setting	<p>Input/operation settings: Input parameters, operation parameters</p> <p>Display settings: Data channel parameters, group parameters, common parameters (combination display, trend vertical/horizontal)</p> <p>Alarm setting</p> <p>File settings (6 files individually): Save method setting</p> <p>Marker text setting</p> <p>System settings: Communication, clock, maintenance, key lock, password, screen, etc.</p>	
	DISP operation	Operation screen selection: Trends, data, bar graph, historical trends, alarm display, marker list Display selection in each screen: Groups 1 to 6 selectable	
Direct writing specifications	Save	Appended to recorded file in internal memory/external memory. External memory files are supported only when recorded data is saved in binary format.	
	Line thicknesses	10 (selectable)	
	Display colors	16 colors (selectable)	
	Drawable screens	Realtime trend, historical trend	
	Max. number of drawn points	8000 per file (raw dots comprising path)	
Option specifications	Alarm relay outputs	<p>Relay contacts are output at alarm generation and input errors.</p> <p>Number of outputs: 24 (normally open contacts), 12 (normally open contacts, normally closed contacts), 6 (normally closed contacts)</p> <p>Contact capacity: 240 Vac 0.2 A (resistive load) 30 Vac 0.3 A (resistive load)</p>	
	Non-voltage contact input (8 points)	Contact input function: Contact inputs, pulse inputs, integration reset, marker write, record to data file in internal memory Start/stop	
	Network Instrumentation Module (Ethernet) communications (scheduled for sale soon)	Reading and recording of data of modules connected on Ethernet * Updating of communications data to record on ARF is dependent on the modules sampling cycle, ARF communication cycle and recording cycle.	
General specifications	Rated power supply voltage	100 to 240 Vac, 50/60 Hz	
	Max. power consumption	65 VA (DO all points ON, 240 Vac)	
	Standard operating conditions	<p>Ambient temperature/humidity ranges 21 to 25 °C, 45 to 65 %RH</p> <p>Power supply voltage 100 Vac±1.0 %</p> <p>Power supply frequency 50/60 Hz ±0.5 %</p> <p>Attitude Left-right/forward tilt 0°, backward tilt 0°</p> <p>Warm-up time 30 mins or more</p>	
	Normal operating conditions	<p>Ambient temperature/humidity ranges 0 to 50 °C, 20 to 80 %RH</p> <p>Power supply voltage 90 to 264 Vac</p> <p>Power supply frequency 50/60 Hz ±2 %</p> <p>Attitude Left-right/forward tilt 0°, backward tilt 0 to 20°</p>	

General specifications	Transportation conditions	In packaged state before shipment from the factory Ambient temperature/humidity range -20 to +60 °C, 5 to 90 %RH (no condensation) Vibration 10 to 60 Hz, 4.9 m/s ² or less Shock 392 m/s ² or less
	Storage conditions	Ambient temperature/humidity range -20 to +60 °C, 5 to 90 %RH (no condensation)
	Power failure protection	Settings and data are held on flash memory. A lithium battery backs up the clock and parameter RAM for about 5 years. * To replace the lithium battery, the recorder must be sent back to the factory for repair.
	Insulation resistance	Across secondary terminal and ground 20 MΩ min. at 500 Vdc Across primary terminal and ground 20 MΩ min. at 500 Vdc Across primary and secondary terminals 20 MΩ min. at 500 Vdc
	Dielectric strength	Across secondary terminal and ground 1 minute at 500 Vac Across primary terminal and ground 1 minute at 1500 Vac Across primary and secondary terminals 1 minute at 2300 Vac
	Case assembly	Door frame: ABS resin Case: Ordinary steel plate
	Color	Door frame: Black (Munsell N3.0) Case: Gray (Munsell N7.0)
	Weight	Approx. 7.2 kg
	Mounting method	Imbedded in panel
	Terminal screws	Power terminals/protective ground terminals/communication terminals: M4.0 Measurement input terminals/alarm output terminals/external drive terminals: M3.5
	Safety standard	-

Table 1. Input type/Accuracy ratings

Input type	Measurement range	Indication accuracy
DC voltage	-13.80 to +13.80 mV -27.60 to +27.60 mV -69.00 to +69.00 mV -200.0 to +200.0 mV -500.0 to +500.0 mV -2.000 to +2.000 V	±0.1 %FS±1 digit
(resistor divider built-in)	-5.000 to +5.000 V -10.00 to +10.00 V -20.00 to +20.00 V -50.00 to +50.00 V	
Thermo-couple	K1	-200.0 to +300.0 °C -200.0 to +600.0 °C -200 to +1370 °C ±0.1 %FS±1 digit * -200 to 0 °C: ±0.2 %FS±1 digit
	E	-200.0 to +200.0 °C -200.0 to +350.0 °C -200 to +900 °C
	J	-200.0 to +250.0 °C -200.0 to +500.0 °C -200 to +1200 °C
	T	-200.0 to +250.0 °C -200.0 to +400.0 °C
	R	0 to 1200 °C 0 to 1760 °C ±0.1%FS±1digit * 0 to 400°C: ±0.2%FS±1digit
	S	0 to 1300 °C 0 to 1760 °C
	B	0 to 1820 °C ±0.1%FS±1digit * 0 to 400°C: Non-standard * 400 to 800°C: 0.15%FS±1digit
	N	-200.0 to +400.0 °C -200.0 to +750.0 °C -200 to +1300 °C ±0.15%FS±1digit * -200 to 0°C: ±0.3%FS±1digit
	W-WRe26	0 to 2315 °C ±0.15 %FS±1 digit * 0 to 100 °C: ±4 %FS±1 digit * 100 to 400 °C: ±0.5 %FS±1 digit
	WRe5-WRe26	0 to 2315 °C ±0.2 %FS±1 digit

Input type	Measurement range	Indication accuracy
Thermo-couple	PtRh40-PtRh20	0 to 1888 °C ±0.2 % FS±1digit * 0 to 300 °C: ±1.5 %FS±1digit * 300 to 800 °C: ±0.8 %FS±1digit
	NiMo-Ni	-50.0 to +299.0 °C -50 to +1310 °C -50.0 to +600.0 °C ±0.2 %FS±1digit
	CR-AuFe	0.0 to 280.0K ±0.2 %FS±1digit * 0 to 20 K: ±0.5 %FS±1 digit * 20 to 50 K: ±0.3 %FS±1 digit
	Platinel II	0.0 to 350.0°C 0.0 to 650.0°C 0 to 1395°C ±0.15 %FS±1 digit
	U	-200.0 to +250.0 °C -200.0 to +500.0 °C -200.0 to +600.0 °C ±0.15 %FS±1 digit * -200 to 0 °C: ±0.3 %FS±1 digit
	L	-200.0 to +250.0 °C -200.0 to +500.0 °C -200 to +900 °C ±0.1%FS±1digit * -200 to 0 °C: ±0.2 %FS±1 digit
Resistance temperature detector (RTD)	Pt100	-140.0 to +150.0 °C -200.0 to +300.0 °C -200.0 to +850.0 °C ±0.1 %FS±1 digit * -140.0 to +150.0 °C, 700 to 850 °C: 0.15 %FS±1 digit
	JPt100	-140.0 to +150.0 °C -200.0 to +300.0 °C -200.0 to +649.0 °C ±0.1 %FS±1 digit * -140.0 to +150.0 °C: ±0.15 % FS±1 digit
	Pt50	-200.0 to +649.0 °C ±0.1 %FS±1 digit
	Pt-Co	4.0 to 374.0 K ±0.15 %FS±1 digit * 4 to 50 K: ±0.3 %FS±1 digit

Note) The indication accuracy applies under standard conditions.
Thermocouple input does not include reference junction compensation accuracy.
K, E, J, T, R, S, B, N: IEC584, JIS C1602-1995
W-WRe26, WRe5-WRe26, PtRh40-PtRh20, Platinel II, NiMo-Ni, CR-AuFe: ASTM Vol14.03
U(Cu-CuNi), L(Fe-CuNi) : DIN43710
Pt100: IEC751(1995), JIS C1604-1997,
JPt100: JIS C1606-1989

Display/Setting screens

Realtime trend screen

- The measured values of each input channel are displayed as trends in realtime.
- Tag/numerical value display, scale gradation hide/display and vertical/horizontal switching are possible.

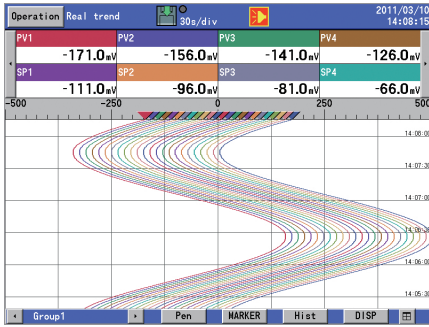

Data display

- The measured values of each input channel are displayed as numerical values in realtime.

PV1	PV2	PV3	PV4
20.4 mV	35.4 mV	50.4 mV	65.4 mV
80.4 mV	95.4 mV	110.4 mV	125.4 mV
A-1	A-2	A-3	A-4
140.4 L/Min	155.4 L/Min	170.4 L/Min	185.4 L/Min
CH13	CH14	CH15	CH16
200.4 °C	215.4 °C	230.4 °C	245.4 °C
CH17	CH18	CH19	CH20
260.4 °C	274.5 °C	289.5 °C	304.5 °C
CH21	CH22	CH23	CH24
319.5 °C	334.5 °C	349.5 °C	364.5 °C

Dual trend screen

- Historical trends and realtime trends are displayed simultaneously. This screen is handy for comparing waveforms.

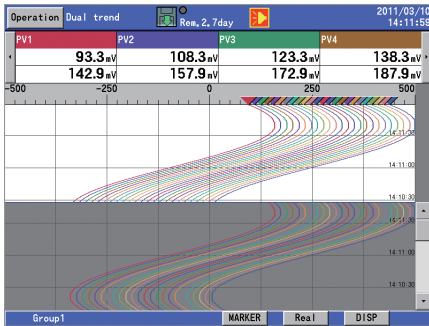

4 screen simultaneous display

- Individual screens can be switched to by directly touching them.



Marker input

- Markers (comments) can be written on realtime trends. When writing markers, either select from pre-registered text strings or input text directly.

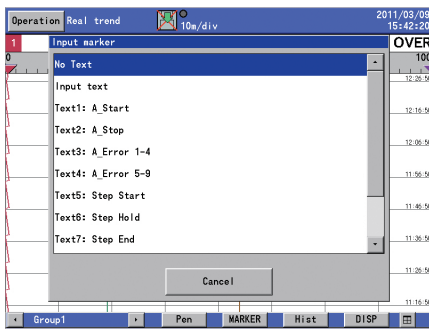

Alarm display

- A list of alarms that were generated and recovery times are displayed.
- You can jump to historical trends by selecting a specific alarm.

Activation time	Cancel time	CH	Type
03/09 16:16:40	03/09 16:16:46	PV1	AL1 Upper
03/09 16:16:35	03/09 16:16:39	PV1	AL2 Lower
03/09 16:16:30	03/09 16:16:35	PV1	AL1 Upper
03/09 16:16:25	03/09 16:16:28	PV1	AL2 Lower
03/09 16:16:20	03/09 16:16:25	PV1	AL1 Upper
03/09 16:16:15	03/09 16:16:18	PV1	AL2 Lower
03/09 16:16:10	03/09 16:16:15	PV1	AL1 Upper
03/09 16:16:05	03/09 16:16:08	PV1	AL2 Lower
03/09 16:16:00	03/09 16:16:05	PV1	AL1 Upper
03/09 16:15:55		PV2	AL4 D, low
03/09 16:15:55		PV2	AL3 D, upp
03/09 16:15:55		PV2	AL2 Lower
03/09 16:15:55	03/09 16:15:58	PV1	AL2 Lower
03/09 16:15:53	03/09 16:15:55	PV1	AL1 Upper
03/09 16:15:48	03/09 16:15:52	PV1	AL2 Lower
03/09 16:15:43	03/09 16:15:48	PV1	AL1 Upper

Bar graph screen

- The measured values of each input channel are displayed as a bar graph in realtime.

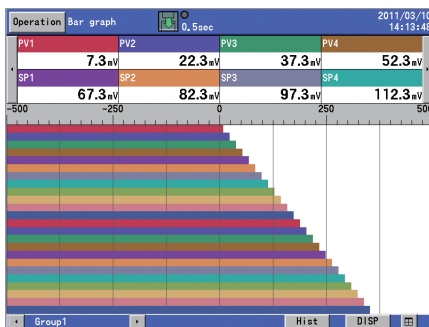

Input setting screen

- Range and other information can be set in menu format for each individual input channel.

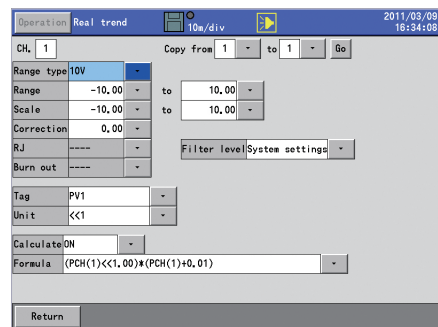

Alarm setting screen

- Information can be set for each individual input channel. Up to four alarms can be set to each channel from among upper limit, lower limit, diff. upper limit, diff. lower limit, and error data.

No.	Type	Value	Ref. CH	Deadband	Delay
AL1	Upper	0.50	1	0.00	0
AL2	Lower	0.30	1	0.00	0
AL3	Diff. upper	0.00	2	0.00	0
AL4	Diff. lower	0.00	2	0.00	0

No.	Relay	AND/OR	MARKER
AL1	0	OR	1
AL2	0	OR	2
AL3	0	OR	0
AL4	0	OR	0

Schedule setting screen

- Recording start/stop schedules can be set.
- Schedules can be set by specific date/time or day of the week.

Date settings	Date	Time
Start date and time	05/01/01	09:00
End date and time	05/01/02	17:00

Day setting	Sun	Mon	Tue	Wed	Thu	Fri	Sat
Usage days	<input type="checkbox"/>	<input type="checkbox"/>	<input type="checkbox"/>	<input type="checkbox"/>	<input type="checkbox"/>	<input type="checkbox"/>	<input type="checkbox"/>
Start time	09:00						
End time	17:00						

Touch panel operation

You can write on the trend screen with the touch pen.

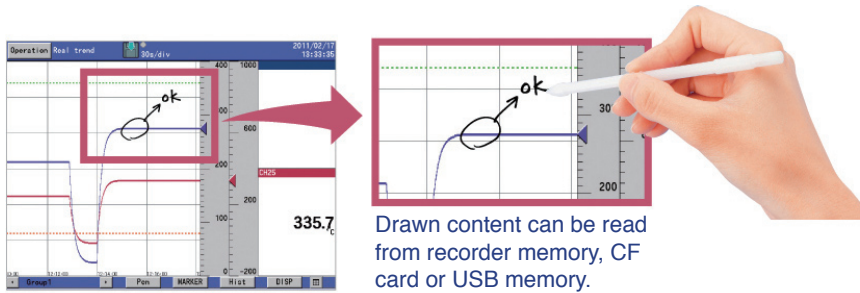

Screens can be scrolled simply by touching the scroll button and moving your finger on screen.



USB memory (host) functions



USB memory can be used in the following ways:

- As media for recording data instead of the CF card
- For automatically saving difference data when the USB memory is inserted
- For copying all recorded files on a CF card to USB memory
- For reading/writing setting files on the ARF recorder

Model number configuration

I	II	III	IV	V	VI	VII	VIII	Notes
Basic model No.	Power supply	Input	Optional function 1	Optional function 2	Optional function 3	Additional treatment 1	Additional treatment 2	
ARF212								12 inputs
ARF224								24 inputs
ARF236								36 inputs
ARF248								48 inputs
	A							100 to 240 Vac, 50/60 Hz
		S						Standard multi-input (100 ms specifications)
		L						Standard multi-input (1 s specifications)
			0					None
			1					12 relay outputs (normally open contacts)
			2					6 relay outputs (normally closed contacts)
			3					24 relay outputs (normally open contacts)
			4					12 relay outputs (normally closed contacts)
			5					12 relay outputs (normally open contacts) + 6 relay outputs (normally closed contacts)
			A					8 non-voltage contact inputs
			B					8 non-voltage contact inputs + 12 relay outputs (normally open contacts)
			C					8 non-voltage contact inputs + 6 relay outputs (normally closed contacts)
			D					8 non-voltage contact inputs + 24 relay outputs (normally open contacts)
			E					8 non-voltage contact inputs + 12 relay outputs (normally closed contacts)
			F					8 non-voltage contact inputs + 12 relay outputs (normally open contacts) + 6 relay outputs (normally closed contacts)
				0				None
					0			None
						0		None
							D	With inspection results
							T	Tropical treatment
							B	With inspection results + tropical treatment
							Y	With traceability certification
							0	None

Optional parts

Model number	Name
ARF910CF0128	CompactFlash card 128 MB
ARF910CF0256	CompactFlash card 256 MB
ARF910CF0512	CompactFlash card 512 MB
ARF910CF1000	CompactFlash card 1 GB
ARF910CF2000	CompactFlash card 2 GB
ARF910ADP000	CompactFlash card adapter for PC
ARF990DA0000	ARF series data analysis tool

Model number	Name
81401325	250 Ω resistors, accuracy ±0.02, 1 pcs
81446642-001	250 Ω resistors, accuracy ±0.05, 2 pcs

External dimensions

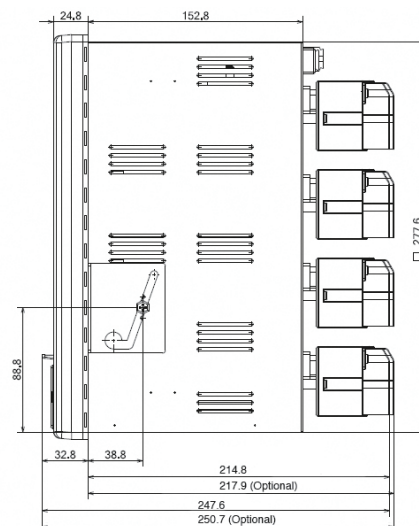
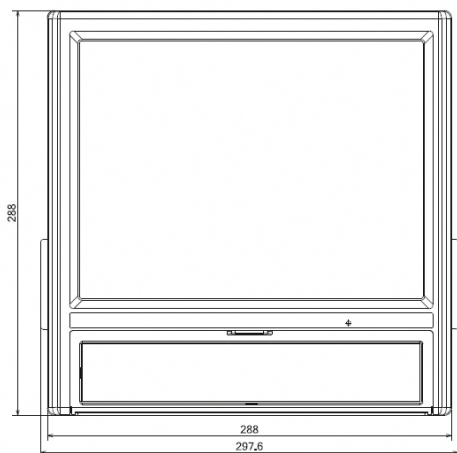

(Unit: mm)

Panel cutout dimensions

(Unit: mm)

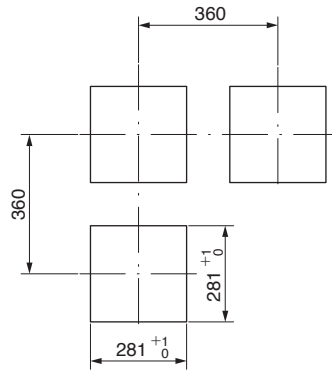

Terminal connection diagram

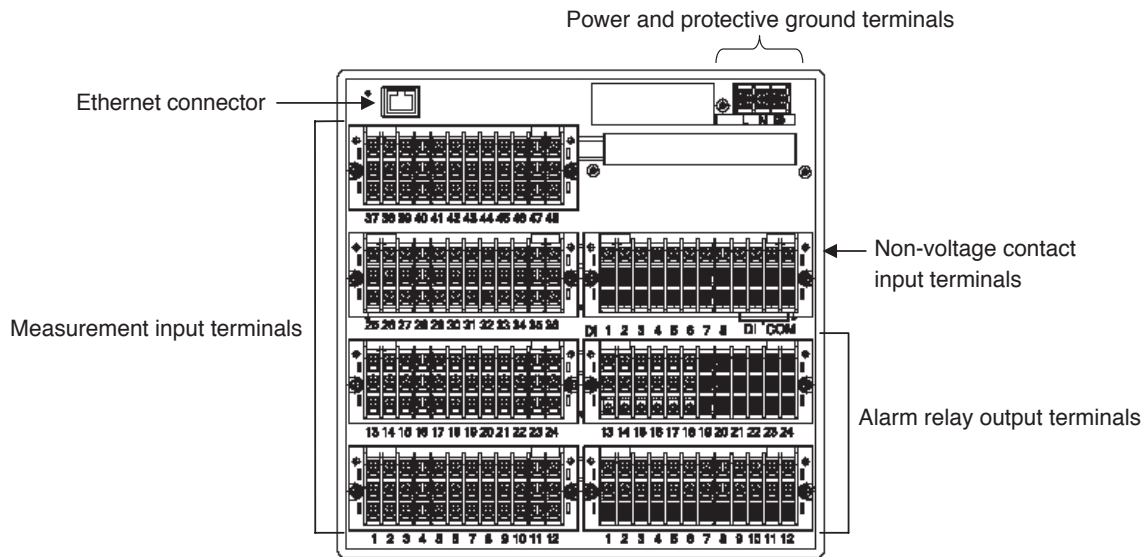

Please, read 'Terms and Conditions' from following URL before the order and use.

<http://www.azbil.com/products/bi/order.html>

Specifications are subject to change without notice.

azbil

Azbil Corporation
Advanced Automation Company

1-12-2 Kawana, Fujisawa
Kanagawa 251-8522 Japan
URL: <http://www.azbil.com/>

1st edition: Mar. 2011
3rd edition: Jan. 2016

No part of this publication may be reproduced or duplicated without the prior written permission of Azbil Corporation.