



***Oil and Gas Barrel Pumps  
ISO 13709/API 610 (BB5) Between Bearings,  
Multistage, Double Case Pumps***

WXB, BP, WCC, HDO/HSO, WIK



***Experience In Motion***



## Supplier of Choice to the Global Oil and Gas Industry

For over 150 years, Flowserve has pioneered many of the most significant advancements in petroleum-related pumping technology. Flowserve developed the first double case pump for hot oil in 1926 and introduced high pressure water and CO<sub>2</sub> injection pumps in 1934. In 1982, Flowserve built the world's largest water injection pump, requiring 17 900 kW (24 000 hp). And since 1938 Flowserve has been in the vanguard of hydraulic decoking with numerous "firsts" and innovations to its credit.

Further reflecting its industry leadership, Flowserve continues to be involved in establishing the ISO 13709/API 610 (BB5) standard governing the construction of double case pumps. From water injection and pipeline to charge and decoking, Flowserve is the preferred provider of double case pump technology worldwide.

### Engineering Excellence

Flowserve offers both diffuser and volute type double case (barrel) pump models for the oil and gas industries. These pumps are CE compliant and manufactured to stringent criteria, often exceeding those established in the current edition of ISO 13709/API 610 (BB5). Flowserve pump models of this type include:

- WXB diffuser style pump
- BP diffuser style pump
- WCC diffuser style pump
- HDO/HSO dual volute pump
- WIK diffuser style pump

With its broad range of pump designs and manufacturing operations in North and South America, Europe and Asia Pacific, Flowserve is well positioned to meet the needs of barrel pump users worldwide.

### Typical Applications

- Water injection
- Pipeline
- Amine
- Hydrocarbon charge
- Decoking jet water
- Ethylene feed
- Refinery boiler feed
- Power recovery device

### Operating Parameters

- Flows to 4090 m<sup>3</sup>/h (18 000 gpm)
- Differential pressures to 650 bar (9500 psi)
- Temperatures to 450°C (840°F)

### Table of Contents

Introduction .....	2
General Information .....	3
WXB Pump .....	4-5
BP Pump.....	6-7
WCC Pump .....	8-9
HDO/HSO Pumps .....	10-11
WIK Pump .....	12-13
Options and Technical Information .....	14-15



## Oil and Gas Barrel Pumps

### Number One in Barrel Pump Technology

Offering both diffuser and volute inner casing designs, the Flowserve family of oil and gas industry double case (barrel) pumps has evolved from the time-honored designs of these world famous heritage brands:

- Byron Jackson® Pumps
- IDP® Pumps
- Pacific® Pumps
- United Centrifugal® Pumps
- Worthington® Pumps

With this family of pumps, Flowserve is able to precisely and economically tailor an appropriate pump and driver package to all sizes and types of oil and gas industry applications.

### Selection Criteria

Through its extensive experience and engineering expertise in hydraulic design, Flowserve is uniquely positioned to assist customers in selecting the best barrel pump design for their specific applications' needs. By weighing all critical factors, Flowserve application engineers work with customers to select the optimum solution for each application. These factors may include:

#### Hydraulic Conditions

- Flow
- Pressure
- Available NPSH conditions
- Fluid characteristics

#### Mechanical Conditions

- Spared vs. unspared
- Space limitations
- Weight considerations

#### Project Conditions

- Total cost vs. initial cost
- Point of delivery
- Customer preferences
- Power limitations

### Design Classes

**General Purpose Pumps** meet ISO 13709/API 610 (BB5), latest edition requirements and are normally intended to be installed in conjunction with a spare pump. By having an installed spare pump, system availability is maximized while optimizing the upfront cost of much of the equipment.

**Special Purpose Pumps** are typically found in installations featuring a single 100% capacity pump. This is more common where the system design precludes the installation of a spare unit. This high-performance design has an extreme focus on durability and reliability, and achieves it through a no-compromise rotor design. It also features advanced materials, auxiliary seal and lubrication systems, all precisely engineered for unspared service when the loss of the pump will jeopardize the user's process.

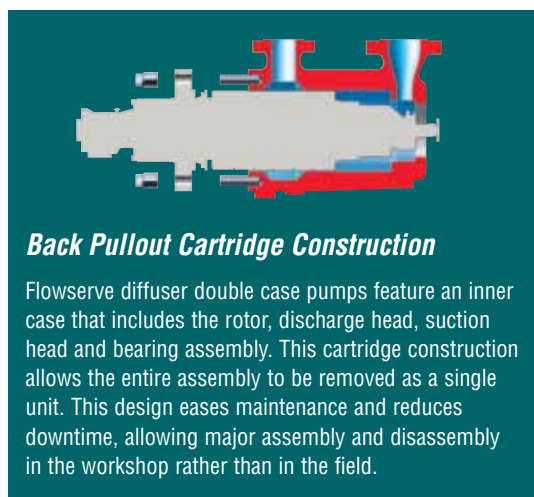

### Back Pullout Cartridge Construction

Flowserve diffuser double case pumps feature an inner case that includes the rotor, discharge head, suction head and bearing assembly. This cartridge construction allows the entire assembly to be removed as a single unit. This design eases maintenance and reduces downtime, allowing major assembly and disassembly in the workshop rather than in the field.



**WXB**  
**Multistage, Diffuser**  
**Barrel Pump**

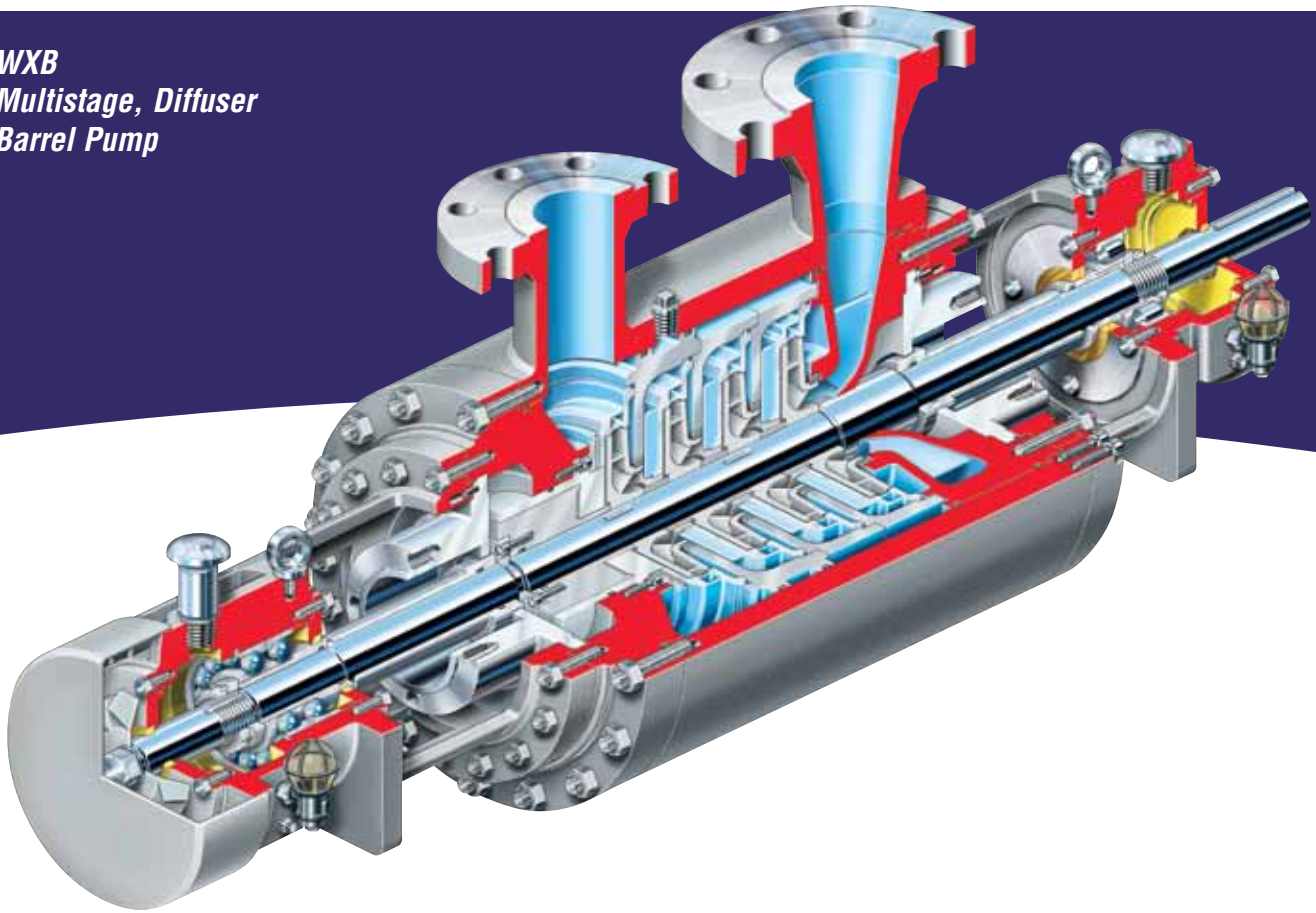

*The WXB is an API style barrel pump that offers features common to API latest edition pumps, such as a cartridge design and renewable wear rings. It is designed for users who need the hydraulic range of a ring section pump, but demand the design and maintenance attributes of a barrel pump.*

Boasting a compact, space-saving design and convenient cartridge-style construction, the WXB is field proven in oil refineries and chemical, power and hydrocarbon plants throughout the world. It is an ideal choice for lower capacity and lower pressure services.

**Typical Operating Parameters**

- Flows to 300 m<sup>3</sup>/h (1320 US gpm)
- Heads to 1200 m (3940 ft)
- Pressures to 150 bar (2175 psi)
- Temperatures to 200°C (390°F)

**Features and Benefits**

**Forged Barrel Casing** materials of construction are available to all ISO 13709/API 610 columns as well as super duplex stainless steel and other high alloys.

**Radially Split Inner Case Subassembly** includes radial and thrust bearings to facilitate inspection and maintenance in the field.

**Generous Shaft Diameter** results in low shaft deflection, thereby increasing bearing, mechanical seal and wear ring life.

**ANSI or DIN Flange Connections** are available to meet customer and application requirements. Other flange standards available upon special request.

**Nozzles** are top suction, top discharge as standard or can be configured side suction, side discharge as an alternate.

**Cartridge-Type Mechanical Seals** are standard and minimize downtime.

**Renewable Wear Rings** are standard on all casings and impellers to permit economical restoration of running clearances.

## Applications

- Produced water re-injection
- Crude oil
- Solvents
- Naphtha
- Wash oil
- Hydrocarbon charge
- Condensate
- Refinery boiler feed
- Booster and recycle



### Multivane Diffuser Construction

With its radially split inner case sub-assembly, the diffuser-casing construction results in balanced radial loads over the entire flow range, including partial-load operation. Ceramic core casting technology produces exceptionally smooth surfaces, enhancing hydraulic efficiency and operation.

### Precision Cast Impellers

Impellers are precision cast and dynamically balanced to ensure hydraulic efficiency and performance repeatability. Other notable features include:

- Multiple hydraulic selections allow pumps to be sized to operate in the best efficiency range
- Large-eye first-stage impeller optimizes NPSH characteristics
- Assembled rotor is checked for run-out to minimize vibration

### Axial Thrust Balancing Device

The WXB pump employs an innovative balancing device that creates nearly constant axial thrust throughout the pump's operating range. This results in minimal balance line flow leading to improved efficiency at all loads.

### Antifriction Bearings

Radial bearings are antifriction rolling element type and thrust bearings are back-to-back angular contact type. Bearings are sleeve mounted to facilitate removal when service for the bearings or the mechanical seals is required. The bearing lubrication system includes an oil bath, a constant level oiler and an oil sight glass.

### Stable Low-Flow Performance

An extension of the well-proven WXB product range, the WXB-B incorporates Barske style impellers to produce stable low-flow performance. It is a reliable, direct drive solution for low-flow, high-head applications.

- Constantly rising head curve induces stable operation at low flows
- ISO/API compliant vibration levels result in high reliability and extended mean time between planned maintenance



**BP**  
**Multistage, Diffuser**  
**Barrel Pump**

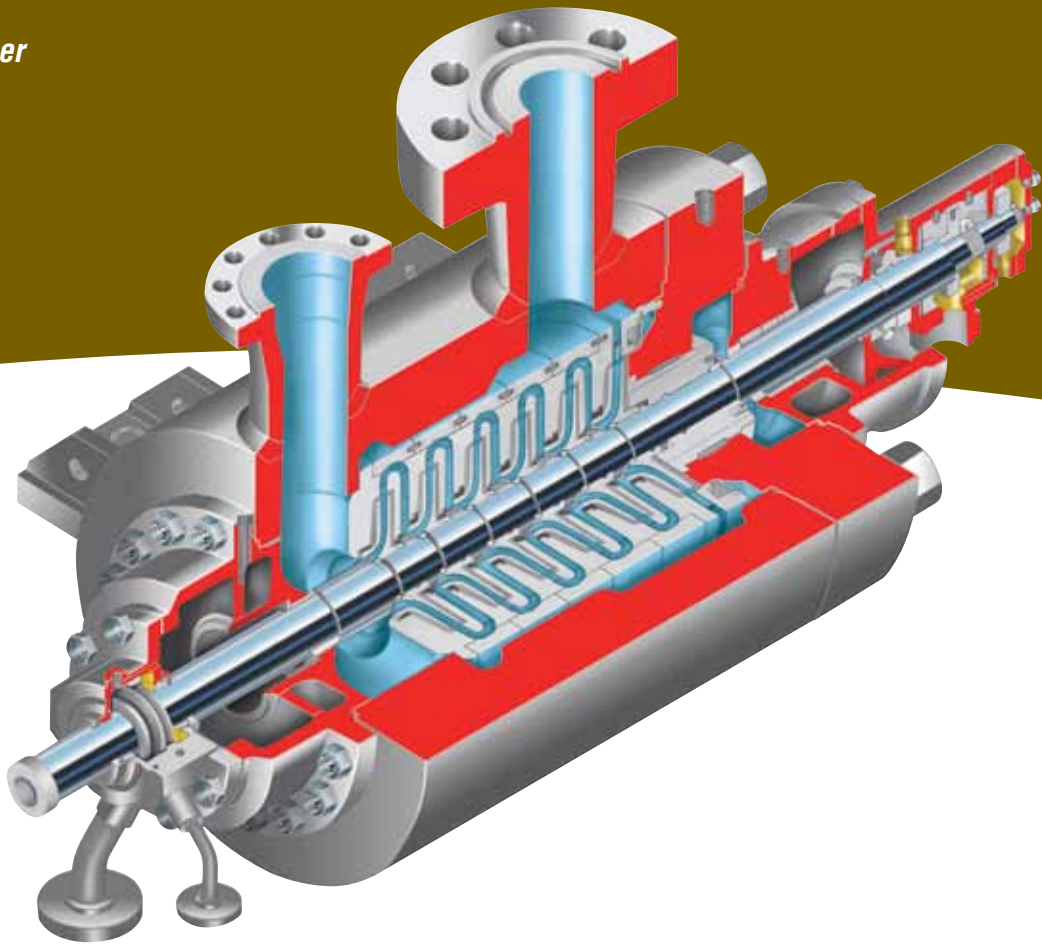

*The BP is a medium-pressure, diffuser-style cartridge barrel pump that meets ISO 13709/API 610 specifications. Hydraulically, the flow and head range of the pump positions it between the WXB and WCC models. Critical portions of its massive forged barrel are analyzed by finite element analysis to withstand high stresses of each application. The center diffuser stack is designed using the latest computational fluid dynamics technology to ensure exceptional efficiency and ultra-low radial loads.*

**Typical Operating Parameters**

- Flows to 1050 m<sup>3</sup>/h (4620 gpm)
- Heads to 3500 m (11 480 ft)
- Pressures to 295 bar (4260 psi)
- Temperatures to 425°C (800°F)
- Speeds to 6000 rpm

**Features and Benefits**

**Barrel Casing** is constructed of forged, carbon-controlled steel and meets ISO 13709/API 610 specifications.

**Shaft** diameter is progressively stepped at each impeller hub, easing replacement of shrink-fit impellers.

**Impellers** are individually secured to the shaft with a clearance fit using split spring-rings. For high-speed or high-temperature services, impellers can be affixed to the shaft by shrink fitting of each stage.

**Spiral-Wound Gaskets** resist the effects of pressure and temperature fluctuations while providing high corrosion resistance.

**Critical Sealing Surfaces** are coated with Inconel<sup>®</sup> providing superior corrosion protection while assuring reliable sealing on high-pressure, high-temperature services.

**ISO 20149/API 682 Seal Chamber** accommodates a wide variety of seal configurations. Cartridge-type single or double mechanical seals are standard.



## Applications

- Reactor charge service
- Desulfurization
- Boiler feedwater
- Descaling
- Other high-temperature and high-pressure services

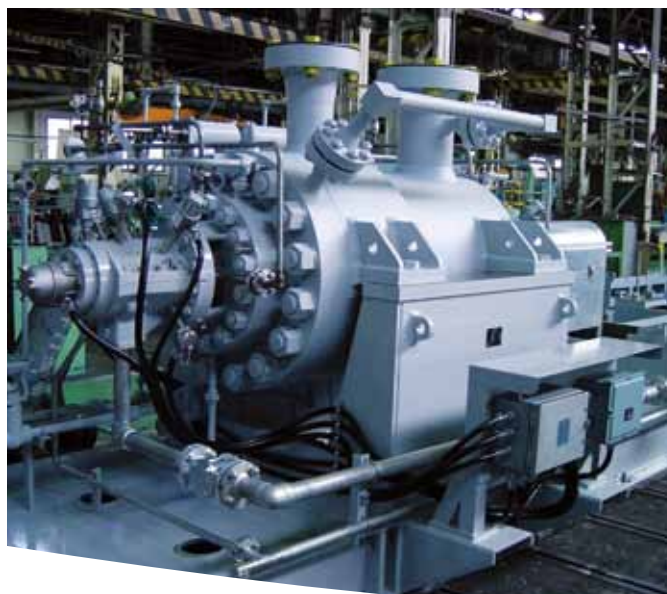

### Multivane Diffuser Construction

The diffuser and return channel vanes are designed for optimal hydraulic performance, streamlining liquid transfer from one stage to the next. With its radially split inner case sub-assembly, the diffuser-casing construction of the BP results in balanced radial loads.

### Cavitation-Resistant Impeller Design

The inlet angle and vane shape of the first-stage impeller are optimized for the conditions of service of each application. Further, an optional double-suction, first-stage impeller is available for services operating with low NPSH available.

### Axial Balancing Device

A straight balancing drum is used for quick and simple assembly of the BP, since no close axial setting is required. Spiral counter-rotating grooves on the inside of a stationary balancing ring are used to restrict internal leakage flow and prevent its seizing to the matching wear surface. The balancing drum is shrink fit to the shaft adjacent to the last-stage impeller.

### High-Temperature Construction

An element spring located at the discharge end of the inner case subassembly allows the assembly to move freely with thermal expansion. The rotating assembly will not bind even during large temperature transients.

### Antifriction Bearings

In the majority of BP pump applications, pressure-lubricated tilting pad axial bearings are utilized with journal-type bearings used in the radial position. In applications where operating parameters allow, rolling-contact antifriction bearings may be specified.



**WCC**  
**Multistage, Diffuser**  
**Barrel Pump**

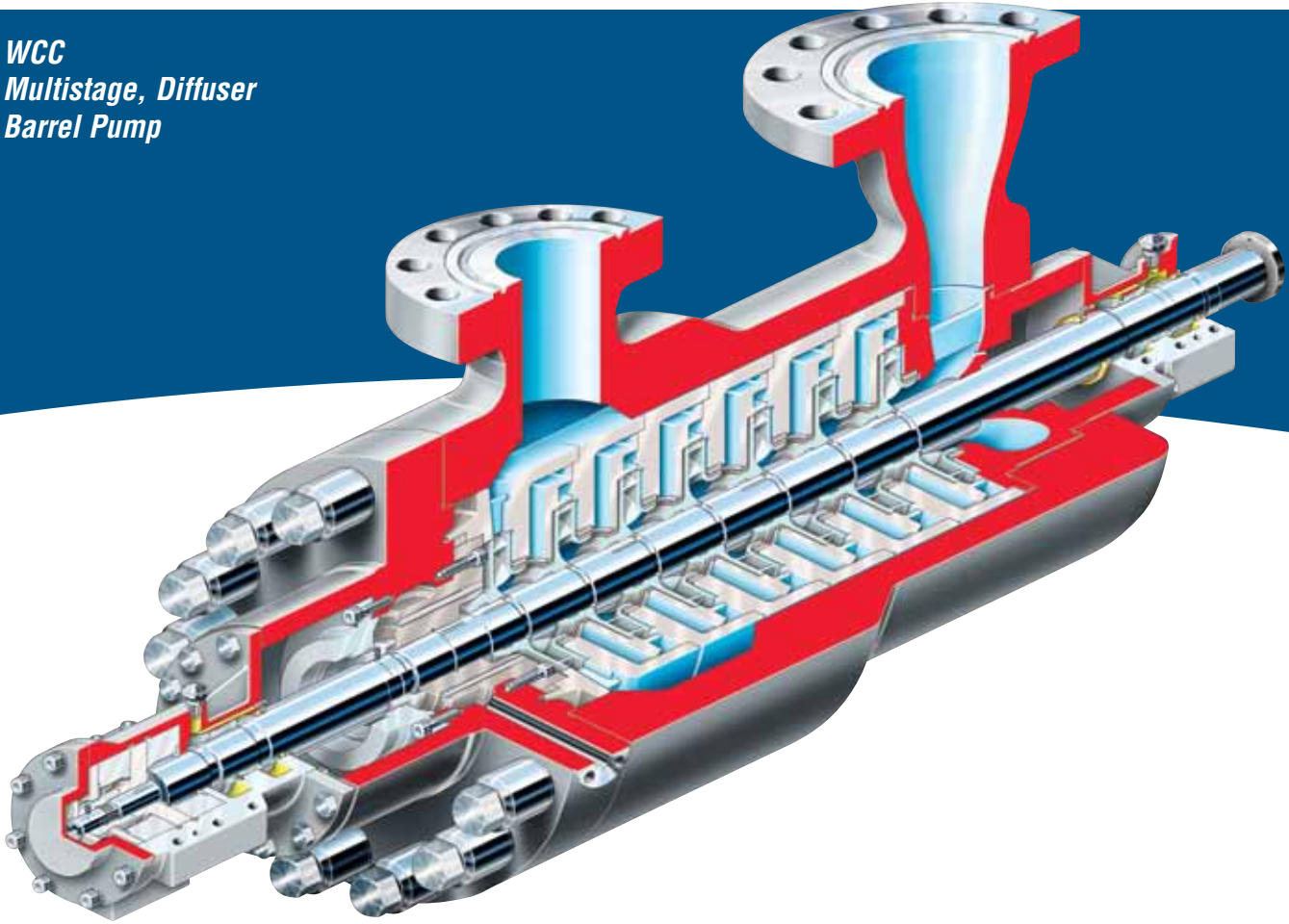

*When process requirements demand a fully compliant, ISO 13709/API 610 pumps, but also call for a flexible, cost-efficient solution, the WCC is the optimum choice. With its extensive list of options and metallurgical choices, it can fit almost any oil and gas application. In addition, the WCC features a trusted legacy design, which is proven in a worldwide installation base. It also includes several standard features, like an inner element cartridge design that makes the pump compact and maintenance friendly.*

**Typical Operating Parameters**

- Flows to 1020 m<sup>3</sup>/h (4500 US gpm)
- Heads to 4270 m (14 000 ft)
- Pressure ratings to 270 bar (4000 psi)
- Temperatures from -5°C (-20°F) to 425°C (800°F)
- Speeds to 7000 rpm

**Features and Benefits**

**Barrel Casing and Discharge Head** materials of construction meet all ISO 13709/API 610 columns, including:

- Carbon steel
- High chrome steel
- Austenitic stainless steel
- Duplex stainless steel

**Nozzles** are top suction, top discharge as standard or can be configured side suction, side discharge as an alternate. Flange facing is raised face as standard with options for ring-type joint or weld-end. Ratings to 170 PN (2500 lb) are available.

**Sleeve Radial and Tilting Pad Thrust Bearings** are normally supplied as standard for the WCC pump due to their reliability and versatility. In lower energy applications, antifriction bearings can be supplied as a cost-saving alternative either in conjunction with self-lubricated sleeve bearings or as a complete antifriction configuration. When space is at a premium, a space-saving integral lubrication circulation system can be supplied, offering the benefits of circulation while maintaining a compact size and minimizing maintenance demands.



## Applications

- Water injection
- Pipeline
- Amine
- Hydrocarbon charge
- Ethylene feed
- Refinery boiler feed
- Power recovery device



### Multivane Diffuser Construction

The WCC's precision cast multivane diffuser collects and diffuses the high-velocity flow from the impeller. Both the diffuser and return guide vanes are integral to each stage piece, forming the inner casing. A continuous metal-to-metal seal between stage pieces minimizes risk of internal leakage.

### Precision Cast Impellers

Impellers are precision cast to ensure optimum hydraulic efficiency and repeatability of performance. Available with integral or optional separate wear rings, impeller wear surfaces are engineered for the best possible performance. Standard materials can be upgraded with customized surface treatments like laser hardening, Stellite® or HVOF for better durability in more difficult services.

### Single-Diameter Balance Drum

The single-diameter balance drum compensates for residual axial thrust produced by the tandem impeller arrangement. The drum may be plain or serrated as appropriate for the application to reduce leakage and optimize reliability and efficiency. It is installed via an interference fit against a step in the shaft and located axially with a split ring. It is also keyed to the shaft to prevent slippage.



Single-diameter balance drum

### Tandem Impeller Rotor Design

The standard WCC rotor is built on a robust, forged shaft. The primary design is constructed with precision fit, heavy hub impellers in a tandem configuration. This design simplifies maintenance while increasing rotor stability. A shrink-fit rotor construction is available for extreme temperatures or speeds. This rotor enhancement may be complemented through the addition of long life wear rings featuring the latest in hard coating technology.

### Optional Shear Ring Closure System

As an option, a shear ring closure system replaces the traditional bolting on the discharge cover. In this configuration, the high-strength split seal ring is locked into the barrel body by cap nuts. This design maintains cartridge integrity but still allows maintenance with conventional tooling. The shear ring design is more compact and boasts one of the quickest maintenance turnarounds in the industry.

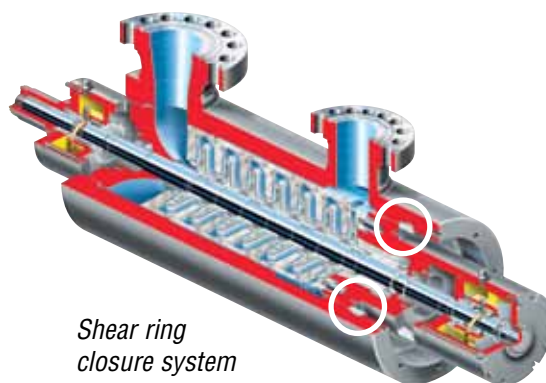

Shear ring closure system

## HDO/HSO Multistage, Volute Barrel Pumps

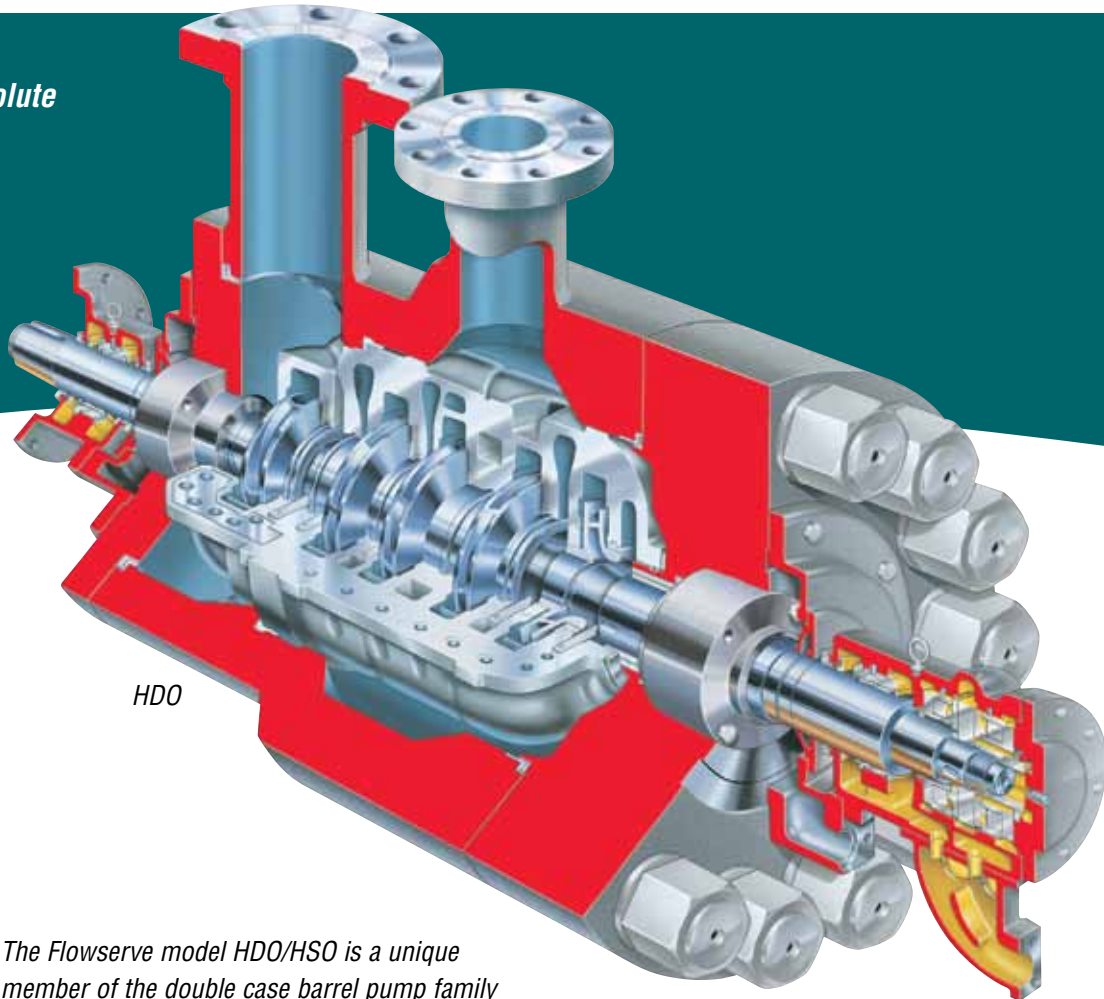

The Flowserve model HDO/HSO is a unique member of the double case barrel pump family in that it is offered in both General Purpose and Special Purpose configurations. Both configurations are fully compliant with ISO 13709/API 610.

The General Purpose HDO/HSO is designed for those users who have an installed spare but prefer a volute design. Featuring a hydraulic envelope that fits many general service applications, the HDO/HSO offers a volute solution for customers who do not need the premium design features and expense of a Special Purpose pump, but still desire the advantages of a volute design.

For applications that require the highest reliability and the features of a volute design, the Special Purpose HDO/HSO is the optimum choice. The Special Purpose volute design retains all of the advantages of a volute double case while offering enhanced features for service in critical processes.

### Typical Operating Parameters

- Flows to 4000 m<sup>3</sup>/h (17 610 US gpm)
- Heads to 5365 m (16 000 ft)
- Pressures to 450 bar (6525 psi)
- Temperatures to 425°C (800°F)
- Speeds to 9000 rpm

### Features and Benefits

**Pump Design** features two high-pressure, fully confined circular compression gasketed sealing joints to the atmosphere.

**Inner Case Subassembly** consists of hydraulically identical halves which feature dual volutes with outlets 180° apart. This design assures radial balance throughout the entire operating range.

**Nozzles** have standard raised face flanges. Nozzle orientation can be adjusted to suit site requirements. Several nozzle configurations are available. Weld-end, ring-type joint, and tongue and groove flanges are optional.

**Wrought Shafts** are incrementally stepped at each impeller fit for ease of assembly. The standard shaft extension is a shaft end taper.

**Sleeve Journal Radial Bearings** and tilting pad thrust bearings are standard. Fan-cooled duplex ball thrust bearings are available where appropriate and permitted by ISO 13709/API 610 (BB5).



## Applications

- Water injection
- Pipeline
- Amine
- Hydrocarbon charge
- Ethylene feed
- Refinery boiler feed
- Power recovery device



### Double Volute Design

The double volute design of the HDO and HSO pumps balances radial loads at all operational points. This balance reduces harmful vibration and helps ensure dependable performance.

### Precision-Cast Opposed Impellers

Impellers are precision cast to improve hydraulic efficiency and performance repeatability. The impellers are secured to the stepped shaft with a shrink-fit. Axial movement is prevented by split rings. Standard single-suction (HSO) or optional double-suction (HDO), first-stage impellers provide the flexibility to meet a variety of NPSH requirements.

### Axially Balanced Configuration

The volute-type opposed impeller design of the HDO and HSO pumps results in nearly balanced axial hydraulic thrust over the full operating range of the pump. Furthermore, this arrangement limits the pressure breakdown across the running clearances to a maximum of 50% of the pressure differential at the center bushing and the balance stage piece.



HSO

### Forged Barrel Casing and Discharge Head

Barrel casing and discharge head materials of construction are available to all ISO 13709/API 610 columns and include:

- Carbon steel
- High chrome steel
- Austenitic stainless steel
- Duplex stainless steel
- Super duplex stainless steel

Special materials to meet customer requests or specific application requirements are also available.

### Dynamically Balanced Rotor

The fully assembled rotor is dynamically balanced and installed as a complete unit providing excellent rotor dynamic stability.

### Fully Machined Inner Casing Halves

Inner casing halves are fully precision machined and operate under hydraulic compression, thereby eliminating the need for gasketing. Only light bolting is required, facilitating dismantling for maintenance.





**WIK**  
**Multistage, Diffuser**  
**Barrel Pump**

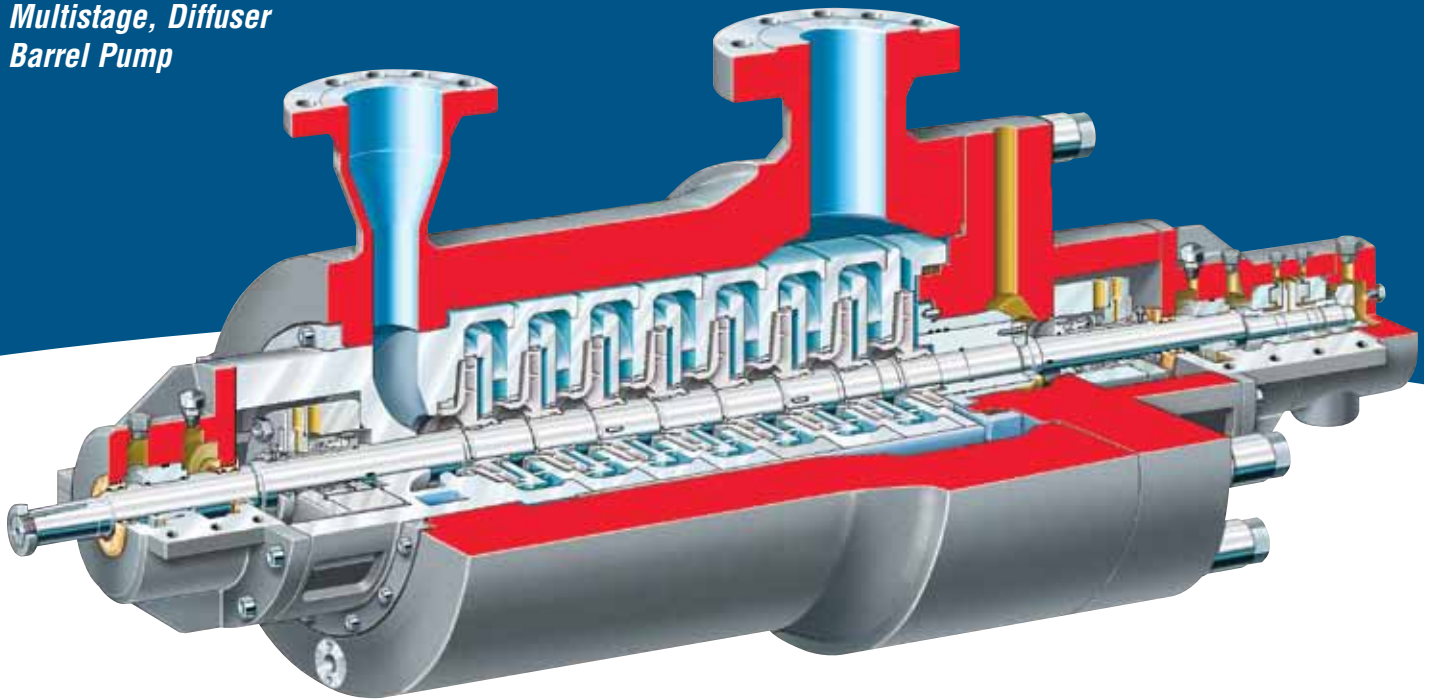

*When the pump specification analysis results in the need to install only one pump and still have unmatched dependability, the WIK is the preferred choice. With a design based on an uncompromised engineering philosophy, the WIK is unmatched by any pump in its class. Fully compliant with ISO 13709/API 610, this Special Purpose diffuser-style pump includes superior rotor dynamics, unequaled mechanical design and a proven record of global experience in unspared service.*

**Typical Operating Parameters**

- Flows to 4000 m<sup>3</sup>/h (17 610 US gpm)
- Heads to 7000 m (23 000 ft)
- Pressure to 650 bar (9425 psi)
- Temperatures to 450°C (840°F)
- Speeds to 9000 rpm

**Features and Benefits**

**High Stiffness Rotor** with low static deflection is the result of large diameter shaft, short bearing spans, unique low specific speed hydraulic designs and high design speeds. This minimizes angularity through the shaft seals and reduces the risk of accidental contact within the running clearances. High mechanical stiffness also improves the pump's ability to tolerate inadvertent vapor-bound operation and reduces sensitivity to wear at running clearances.

**Multi-Vane Radial Split Diffuser and Channel Ring Collectors** are cast components eliminating radial imbalance across the entire operating range. Collectors provide continuous metal-to-metal sealing between stages and between inner and outer casings. Collectors are milled to create smooth passageways and ensure repeatability of performance.

**Large Diameter Shafts** are incrementally stepped at all of the impeller, seal and thrust collar fits for ease of assembly. Shafts are thermally stabilized to eliminate potential distortion from residual stresses.

**Heavy-Duty Journal Type Radial Bearings** are thick walled and pressure-lubricated for long life.

**Heavy-Duty Tilting Pad Thrust Bearings** are leading edge groove (L.E.G.) pressure-lubricated, self-equalizing type. Bearings and forced feed lubricating systems are conservatively sized for each application.

**Normal Single, Dual Pressurized and Unpressurized Mechanical Seals** are contained within a full API 682 seal chamber. Wet and dry gas seals are also available and utilized when appropriate.

**Forged Barrel Casing and Discharge Head** are precision designed for each application and are manufactured from high-strength forgings to ensure unparalleled durability.

## Applications

- Decoking jet water
- Hydrocarbon charge
- Seawater injection
- Produced water re-injection
- Main oil line
- Pipeline
- Lean solution/amine gas processing service
- Reactor feed/ethylene charge
- High-pressure CO<sub>2</sub> injection



### Unique Low Specific Speed Impellers

Precision cast low specific speed impellers are statically and dynamically balanced. Impellers are double keyed and positively secured against axial movement by split rings and a shrink fit on a stepped shaft. Large eye single-suction or alternate double-suction, first-stage impellers are available depending on NPSH conditions. Impeller hubs have integral hardened wear surfaces.

### Single-Diameter Balance Drum

The single-diameter balance drum compensates for the residual axial thrust produced by the tandem impeller arrangement. The sleeve is grooved against the flow to improve rotor stability, lower balancing leak-off flow and reduce the risk of galling in the running clearance. It is mounted with a shrink-fit, key driven and located with a split ring.

### Back Pullout, Cartridge Construction

The standard construction cartridge-style inner case subassembly includes the rotor, diffusers, discharge head, suction head, seals and bearing assemblies. This cartridge-style construction eases maintenance by allowing quick replacement of the entire subassembly. Major assembly, disassembly and mechanical seal and rotor setting can then be performed in the shop rather than in the field. A conventional construction version is also available.

### WIKO: Innovative Opposed Impeller Design For Extreme Pressures

The WIKO was developed to meet ever increasing customer requirements for extreme discharge pressures and the need to balance residual axial thrust. By pairing an opposed impeller rotor with diffuser collectors and a single-diameter balance drum, this design can be customized to meet higher pressures.

Every WIKO is custom designed and built to order for specific ultra high-pressure applications.

WIKO Opposed Impeller Design

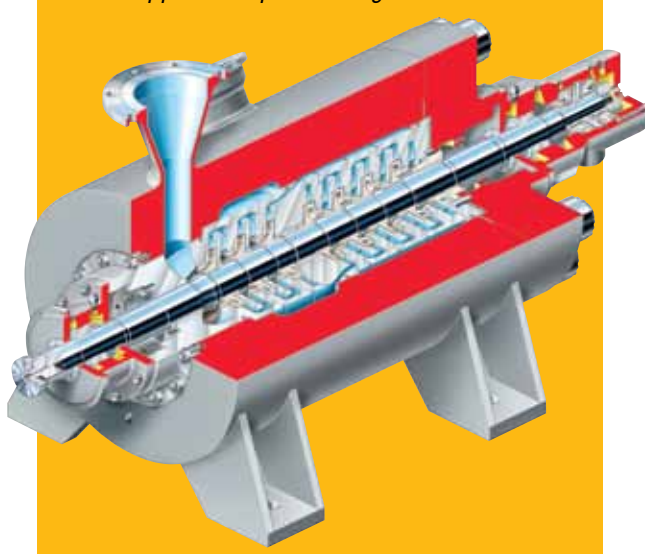

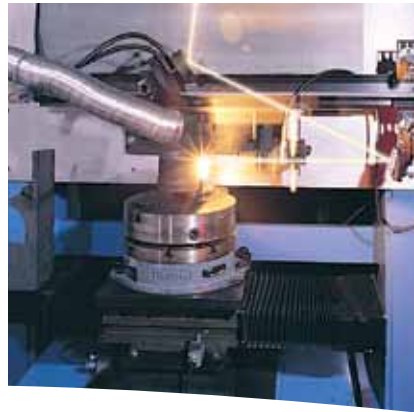

### **Materials of Construction**

The search for new crude feed stocks and advancements in refinery technology continue to extend pump requirements to new limits. As a result the pumps that handle these new liquids must be constantly refined to incorporate improved materials and coatings to extend service life. Materials scientists at Flowserve continually advance the field of abrasion and corrosion resistant materials in pumps by leveraging Flowserve-developed innovations and commercially available solutions from other industries.

### **Baseplate Solutions**

In addition to providing baseplate systems to the basic structures required by API, Flowserve has developed an extensive list of refinements driven by decades of application experience in the most critical applications. A partial list of these refinements includes:

- High nozzle load designs for large pumps
- Spring-loaded baseplates for high-temperature services
- Gimbal-mounted baseplates for offshore applications (shown below)
- Pre-engineered systems with piping included for additional safety

### **Laser-Processing Technologies**

Flowserve offers two advanced laser treatments to create superior surface properties on critical clearance parts. These processes are an effective means of improving component reliability and durability. These treatments include:

- Laser hardening
- Direct laser deposition (DLD)

These treatments are often applied to impeller hubs, impeller wear rings and casing wear rings. The surfacing improves durability and allows more precise optimization of the corresponding clearances. The hydraulic balance surfaces are also frequently treated for improved pump reliability.

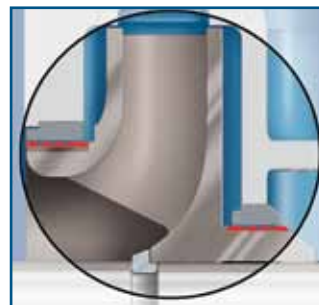

*DLD treated impeller with front and back integral wear rings*





**Options and  
Technical  
Information**

*Single-Suction, First-Stage Impeller*

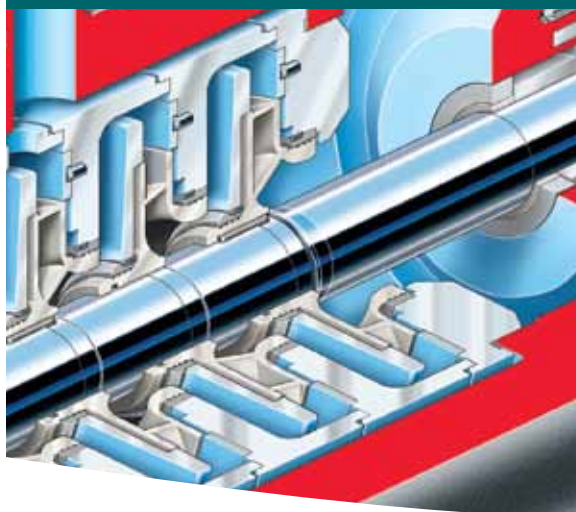

*Double-Suction, First-Stage Impeller*



**Hydraulic Options**

With the industry's most extensive and sophisticated library of hydraulic designs for barrel pumps, Flowserve can offer customized and optimized pump performance for the most difficult applications. Flowserve engineers employ leading-edge techniques that can extend the operating range of the pump or mitigate the risks of damage caused by cavitation.

**Single- or Double-Suction,  
First-Stage Impellers**

Most Flowserve barrel pumps are available with either single- or double-suction, first-stage impellers. Flowserve hydraulic engineers are able to precisely fit a pump to the system requirements with either impeller design. Furthermore, Flowserve engineers have optimized various diameter suction eyes that also can be implemented. The "leading-edge hook" and "bias-wedge" Flowserve designs virtually eliminate cavitation damage, contributing to a smoother running pump while prolonging pump life.

**Pump Diagnostics and Prognostics**

With a new series of intelligent pump products, Flowserve is on the pioneering frontier of pump intelligence. Flowserve has developed pre-engineered solutions that integrate electronics, computer technology, sensors and actuating equipment. These easy-to-use, pump-specific solutions allow barrel pump operators to benefit from monitoring, equipment protection and control, diagnostics and predictive tools that significantly decrease overall pump lifecycle costs. Intelligent Pump Solutions from Flowserve help end users eliminate costly downtime and repairs caused by:

- Cavitation
- Pump overloads
- Excessive wear or rubbing
- Blocked lines
- Dry running



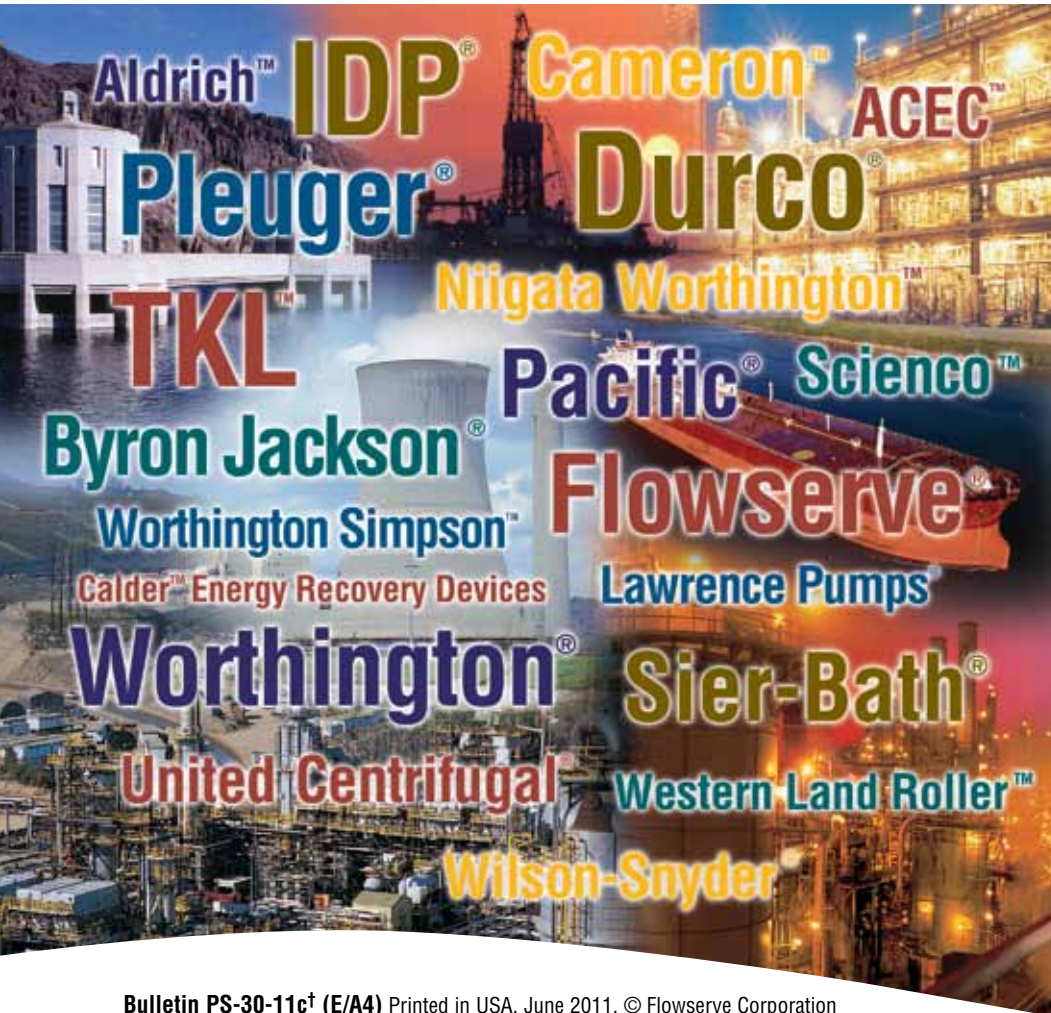

Bulletin PS-30-11c† (E/A4) Printed in USA. June 2011. © Flowserve Corporation

***To find your local Flowserve representative:***

For more information about Flowserve Corporation,  
visit [www.flowserve.com](http://www.flowserve.com) or call +1 937 890 5839.

**USA and Canada**

Flowserve Corporation  
5215 North O'Connor Blvd.  
Suite 2300  
Irving, Texas 75039-5421 USA  
Telephone: +1 937 890 5839

**Europe, Middle East, Africa**

Flowserve Corporation  
Parallelweg 13  
4878 AH Etten-Leur  
The Netherlands  
Telephone: +31 76 502 8100

**Latin America**

Flowserve Corporation  
Martín Rodríguez 4460  
B1644CGN-Victoria-San Fernando  
Buenos Aires, Argentina  
Telephone: +54 11 4006 8700  
Telefax: +54 11 4714 1610

**Asia Pacific**

Flowserve Pte. Ltd.  
10 Tuas Loop  
Singapore 637345  
Telephone: +65 6771 0600  
Telefax: +65 6862 2329