

# SystempaK (Digital/Single Case) Dual Input Arithmetic Relay Module

## Model J-SCP 92/97

### Introduction

The Dual Input Arithmetic Relay Module is a signal conversion module contained in a single case. The Dual Input Arithmetic Relay Module is an advanced arithmetic module that can combine multiple arithmetic operation functions and execute them.

After A/D conversion, the Dual Input Arithmetic Relay Module performs input processing, such as filtering and low cut processing to two points of input (4 to 20 mA/1 to 5V DC). A signal completed with input processing is then processed with arithmetic operations via the arithmetic equations assigned to a maximum of seven processing combo boxes. After output low cut processing, the final output is D/A-converted to 4 to 20 mA/1 to 5V DC.

By selecting one from 25 kinds of arithmetic equations provided as standard equations, an arithmetic function can be easily set on each processing combo box. Of these 25 kinds, assignable arithmetic equations differ from each processing combo box location. A variety of arithmetic functions and input/output processing parameter settings can be implemented using the dedicated Loader Software, which operates on a general-purpose PC.

The Dual Input Arithmetic Relay Module provides the one-output model of J-SCP92 and the two-output model of J-SCP97. In the two-output model, isolation is employed between the two output circuits.



### Specification

- Number of input points: 2 points
- Input signal: 1 to 5V DC or 4 to 20 mA DC
- Input impedance: 1 M $\Omega$  (voltage input), 50  $\Omega$  (current)
- Output signal:
  - No. 1 output; 1 to 5V DC or 4 to 20 mA DC
  - No. 2 output; 1 to 5V DC
  - Edge connector output; 1 to 5V DC (No. 1 output must be 1 to 5V DC when connecting the signal with the A-MC I/O cable.)
- Output impedance:
  - Voltage output; 250  $\Omega$  or less, Current output; 250 k $\Omega$  or more
- Output range: -20 to +120%FS
- Allowable load resistance: 0 to 600  $\Omega$  (Current output: Up to +110%)
- Input/output response:
  - Minimum of 160 msec, 0 to 90% response (Moving average and first-order lag filtering are not provided.)
- Accuracy: 0.15%FS (Excluding arithmetic errors)
- Output update period:
  - 5 msec (Output hardware filtering, 0 to 90% response, 50 msec)
- Insulation resistance: 500V DC, 100 M $\Omega$  min  
(Mutual between input - output - GND - power terminal)
- Withstand voltage: 1000V AC, 1 minute  
(Mutual between input - output - GND - power terminal)
- Power supply: 24V DC  $^{+10}_{-15}$  %
- Current consumption: 130 mA or less (at 24V DC)
- Ambient temperature:
  - Normal operating condition; 5 to 45 $^{\circ}$ C
  - Operation limit; 0 to 50 $^{\circ}$ C
- Ambient humidity: 0 to 90%RH (No condensation allowed)
- Mounting: Panel, wall, DIN rail attachment
- Front mask color: Black
- Weight: 400 g
- Operating influence:
  - Supply voltage effect;  $\pm 0.1\%$ FS/24V DC  $^{+10}_{-15}$  %
  - Temperature effect;  $\pm 0.15\%$ FS/10 $^{\circ}$ C
- Loader settings:
  - Module ID; 16 one-byte characters, 8 two-byte kanji characters
  - Input scaling setting; Zero span setting within input range (Setting of an input such as 0, 100% at each input)
  - Input filtering; Unavailable/available (Moving average)
  - Input low-level cut; Setting of input low-level cut value by % (0 to +120%).
  - Output low-level cut; Setting of output low-level cut value by % (0 to +120%).
  - Output zero span adjustment; Settable to any value within the output range (-20 to +120%FS)
  - Startup delay; Setting of delay time before starting arithmetic actions during power-on startup (0 to 99 seconds)
  - Function setting; Setting of arithmetic functions on processing combo boxes

## Block diagram of arithmetic unit processing

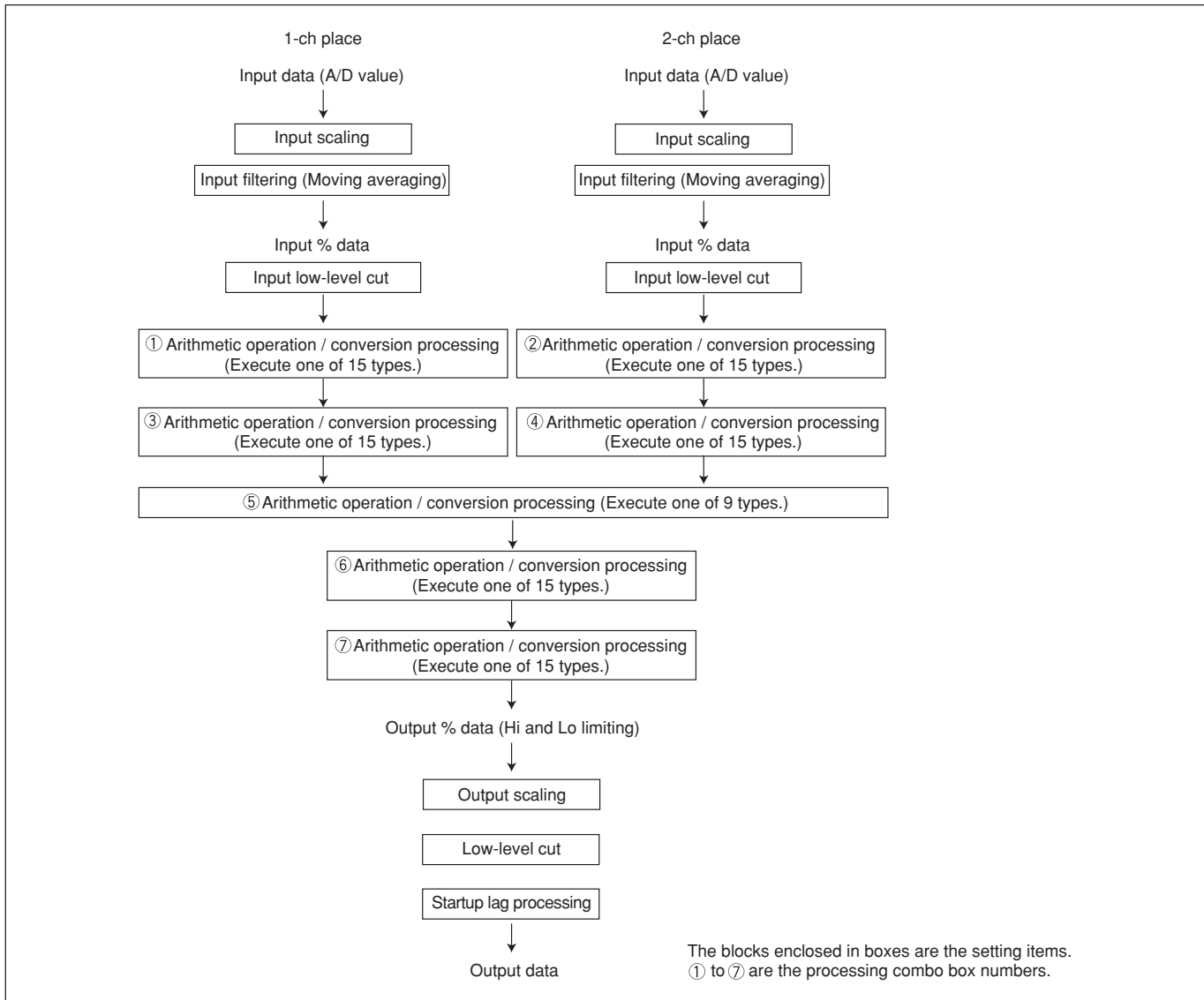

## Description of signal conversion/arithmetic operations

Conversion / operator	Function outline	Processing combo box used	Settings
No processing	No conversion / arithmetic operation	① to ⑦	
Linearization	Sets the output % data for each input % (maximum of 21 points).	① to ④, ⑥, ⑦	±120.00% range
Ratio / bias setting	Arithmetic equation: Select one from the following. Output = Ratio × Input + Bias Output = Ratio × (Input + Bias)	① to ④, ⑥, ⑦	Ratio: -10.000 to 10.000 Bias: -999.99 to 999.99
First-order lag response	Provides a first-order lag response.	① to ④, ⑥, ⑦	0 to 999.9 seconds (63% response)
Gradient response	Provides a response with certain amount of changes. Setting of response time 0 to 100% of output range	① to ④, ⑥, ⑦	Gradient response time: 0.5 to 40.0 sec UP direction, DOWN direction. Time is set individually.
Square root	Input square root extraction	① to ④, ⑥, ⑦	With, without Input/output low-level cut value: 0.00 to 100.00
Reversing	Reverses an input % value for outputting it.	① to ④, ⑥, ⑦	With, without
Low monitor	One-point low monitoring switch Results can be used as DO in the next processing combo box. (No outputs to terminals)	① to ④, ⑥, ⑦	Monitoring setting value: -999.99 to 999.99% Differential: 0.00 to 999.99%
High monitor	One-point high monitoring switch Results can be used as DO in the next processing combo box. (No outputs to terminals)	① to ④, ⑥, ⑦	Monitoring setting value: -999.99 to 999.99% Differential: 0.00 to 999.99%

## Description of signal conversion/arithmetic operations (Continued)

Conversion / operator	Function outline	Processing combo box used	Settings
Deviation monitor	Switch for monitoring deviations from setting values Results can be used as DO to the next processing combo box. (No outputs to terminals)	① to ④ , ⑥ , ⑦	Monitoring setting value: -999.99 to 999.99% Bandwidth: 0.00 to 999.99%
Rate-of-change monitor	Switch for monitoring the one-point rate of change Results can be used as DO to the next processing combo box. (No outputs to terminals)	① to ④ , ⑥ , ⑦	Rate of change Hi: 0.0 to 999.9%/second Rate of change Lo: 0.0 to 999.9%/second
Scaling	Converts an input value scale. Used together with temperature correction and pressure correction.	① to ④ , ⑥ , ⑦	Scale low (-999.99 to 999.99 No indication of unit) Scale high (-999.99 to 999.99 No indication of unit)
High/low limiter	Limits the high/low of an input value.	① to ④ , ⑥ , ⑦	Low limit setting value: -999.99 to 999.99% High limit setting value: -999.99 to 999.99%
Rate-of-change limiter	Limits the rate of change of an input value.	① to ④ , ⑥ , ⑦	Rate of change Up: 0.0 to 999.9%/second Rate of change Down: 0.0 to 999.9%/second
Preset value	When the DI input (DO from previous arithmetic operation) is ON: Outputs a specified preset value. When OFF: Outputs an input value without any presetting.	① to ④ , ⑥ , ⑦	Pre-set value: -999.99 to 999.99%
Preset with ramping	When the DI input (DO from previous arithmetic operation) is ON: Outputs a specified preset value. (Change function at certain gradients available) When OFF: Outputs an input value without any presetting.	⑤	Pre-set value: -999.99 to 999.99% Gradient: 0.01 to 999.99%/second
High/Low selector	Outputs a bigger input. Outputs a smaller input.	⑤	With, without
Switch selector	Selects between two signals, based on the DI input and then outputs a selected signal.	⑤	With, without
Switch with ramping	Selects between two signals, based on the DI input and then outputs a selected signal. Can change an output at a certain gradient during switching.	⑤	Gradient: 0.01 to 999.99%/second
Temperature Compensation	Compensates the temperature for the rate of gaseous flow. [For Celsius] Output (%) = 2-ch value (%) × (273 + Design temperature*) / (273 + 1-ch value**) ** A value converted into a temperature value by scaling processing	⑤	* Design temperature: -300.00 to 2000.00 Temperature unit: Celsius (°C), Fahrenheit (F)
Pressure Compensation 1	Compensates the pressure for the rate of gaseous flow. Output (%) = 2-ch value (%) × (1.033 + 1-ch value*) / (1.033 + Design pressure **) * A value converted into a pressure value by scaling processing	⑤	** Design pressure: -999.9 to 999.9 kg/cm <sup>2</sup>
Pressure Compensation 2	Compensates the pressure for the rate of gaseous flow. Output (%) = 2-ch value (%) × (10330 + 1-ch value*) / (10330 + Design pressure **) * A value converted into a pressure value by scaling processing	⑤	** Design pressure: -999.9 to 999.9 mm H <sub>2</sub> O
Addition, Subtraction	Adds/subtracts two inputs. Output % = (Coefficient 1 / 100) × 1-ch value (%) + (Coefficient 2 / 100) × 2-ch value (%)	⑤	Coefficient 1: -1000.0 to 1000.0 Coefficient 2: -1000.0 to 1000.0
Multiplication	Output % = {(Coefficient 1 / 100) × 1-ch value (%) + {(Coefficient 2 / 100) × 2-ch value (%)}	⑤	Coefficient 1: -1000.0 to 1000.0 Coefficient 2: -1000.0 to 1000.0
Division	Output % = {1-ch value (%) / 2-ch value (%)} × (Coefficient 1 / 100) + Coefficient 2 Setting of interchanging between the numerator and denominator of a fraction is available.	⑤	Coefficient 1: -1000.0 to 1000.0 Coefficient 2: -1000.0 to 1000.0 [Specifying of denominator]: 1-ch value (2ch / 1ch) 2-ch value (1ch / 2ch)

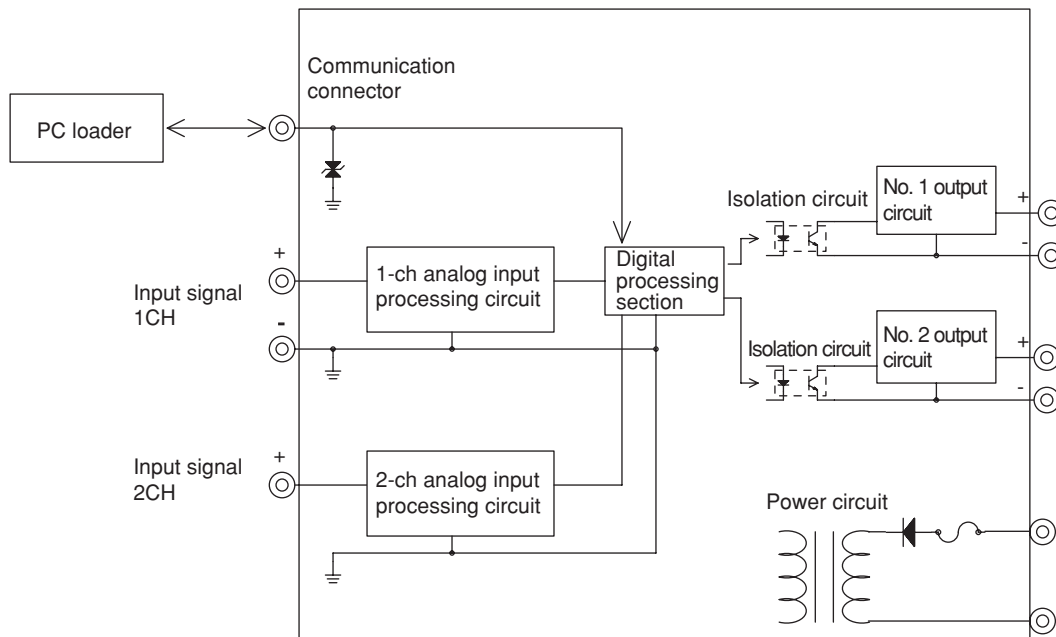

Figure 1. Functional configuration diagram of Dual Input arithmetic unit

### Model Number Table

One-output model

Basic Model Number	Selections		Additions	Description
	I	II	I	
J-SCP92				Dual Input Arithmetic Relay Module (One-output model)
	X			No varnish coated
	C			Varnish coated
		-1		Input: 1 to 5V DC
		-2		Input: 4 to 20 mA DC
			1	Output: 1 to 5V DC
			2	Output: 4 to 20 mA DC
				-0 Without test report
				-1 With test report

Two-output model

Basic Model Number	Selections		Additions	Description
	I	II	I	
J-SCP97				Dual Input Arithmetic Relay Module (Two-output model)
	X			No varnish coated
	C			Varnish coated
		-1		Input: 1 to 5V DC
		-2		Input: 4 to 20 mA DC
			1	No. 1 output: 1 to 5V DC, No. 2 output: 1 to 5V DC
			2	No. 1 output: 4 to 20 mA DC, No. 2 output: 1 to 5V DC
				-0 Without test report
				-1 With test report

Example: J-SCP92X-11-0

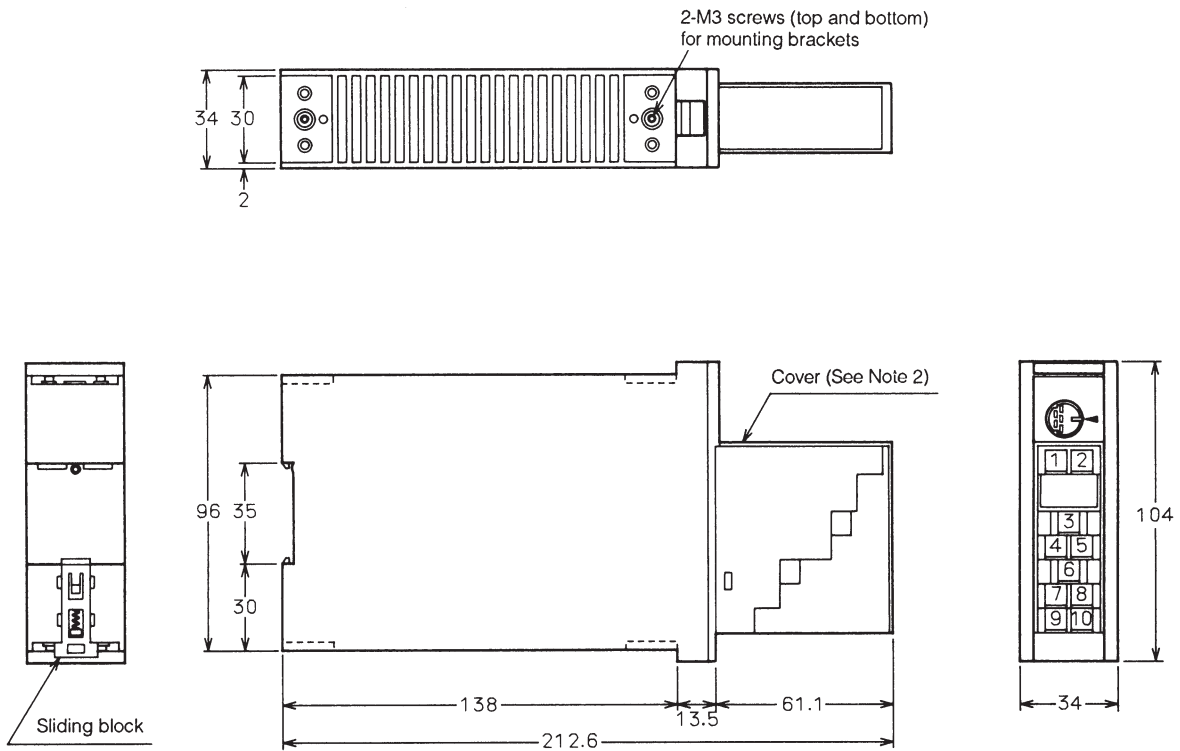

No.	Description
1	2-ch input (+)
2	Input common (-)
3	Input 1-ch input (+)
4	No.1 output (+)
5	No.1 output (-)
6	No.2 output (+) (Note 1)
7	No.2 output (-) (Note 1)
8	24V (PS +)
9	GND
10	0V (PS -)

- Notes: 1) For two-output model.  
 2) Operate the Module with a cover.  
 3) Terminal screws: M3.5  
 4) Use the pressured terminals with insulation sheath.

**Figure 2. Dimensions and wiring diagram**

MEMO

# MEMO

When ordering, please specify:

- Tag number

Input filtering is set to "Moving average available" by default.

In the arithmetic function, an operation is configured by default at the time of shipment, such that the ratio/bias (Ratio: 0.5, Bias: 0%) arithmetic operation is performed on each of the two inputs and the result is added to.

Please read the "Terms and Conditions" from the following URL before ordering or use:

<http://www.azbil.com/products/bi/order.html>

The logo for Azbil Corporation, featuring the word "azbil" in a bold, lowercase, sans-serif font.

*Specifications are subject to change without notice.*

## Azbil Corporation

Advanced Automation Company

1-12-2 Kawana, Fujisawa

Kanagawa 251-8522 Japan

URL: <http://www.azbil.com/>

2nd edition: Jan. 2013

*No part of this publication may be reproduced or duplicated without the prior written permission of Azbil Corporation.*