

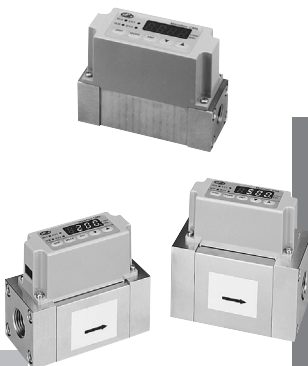

## CMS Series SUS/SUS316 Gas Mass Flowmeters

CMS9500/ 0002/ 0005/  
0020/ 0050/ 0200/ 0500

### User's Manual



Thank you for purchasing a CMS Series flowmeter.

This manual contains information for ensuring correct use of the CMS Series. It also provides necessary information for installation, maintenance, and troubleshooting.

This manual should be read by those who design and maintain devices that use the CMS Series. Be sure to keep this manual nearby for handy reference.

Azbil Corporation

**Please read the "Terms and Conditions" from the following URL before ordering or use:**

**<http://www.azbil.com/products/bi/order.html>**

---

---

#### **NOTICE**

Be sure that the user receives this manual before the product is used.

Copying or duplicating this user's manual in part or in whole is forbidden. The information and specifications in this manual are subject to change without notice.

Considerable effort has been made to ensure that this manual is free from inaccuracies and omissions. If you should find an error or omission, please contact Azbil Corporation.

In no event is Azbil Corporation liable to anyone for any indirect, special or consequential damages as a result of using this product.

---

---

© 2006-2012 Azbil Corporation All Rights Reserved.

$\mu$ F™, Micro Flow™ are trademarks of Azbil Corporation in Japan.

# SAFETY PRECAUTIONS

## ■ About Icons

The safety precautions described in this manual are indicated by various icons. Please be sure you read and understand the icons and their meanings described below before reading the rest of the manual.

Safety precautions are intended to ensure the safe and correct use of this product, to prevent injury to the operator and others, and to prevent damage to property. Be sure to observe these safety precautions.



### WARNING

Warnings are indicated when mishandling this product might result in death or serious injury.



### CAUTION

Cautions are indicated when mishandling this product might result in minor injury to the user, or only physical damage to the product.

## ■ Examples

	Triangles warn the user of a possible danger that may be caused by wrongful operation or misuse of this product. These icons graphically represent the actual danger. (The example on the left warns the user of the danger of electric shock.)
	White circles with a diagonal bar notify the user that specific actions are prohibited to prevent possible danger. These icons graphically represent the actual prohibited action. (The example on the left notifies the user that disassembly is prohibited.)
	Filled-in black circles instruct the user to carry out a specific obligatory action to prevent possible danger. These icons graphically represent the actual action to be carried out. (The example on the left instructs the user to remove the plug from the outlet.)

# **WARNING**



If this device is used for a flammable gas, mount it on the upstream side of the safety shutoff valve. If somehow air or oxygen gets into the pipes and an explosive mixture is produced, and if the sensor should make a spark due to lightning or some other reason, the gas mixture in the pipes could explode.



Never allow a gas that is within explosive limits to enter this device. Doing so could cause an explosion.



If a model designed for use with oxygen has been used for other gases, do not use it again for oxygen. Doing so could cause a serious accident.



A model designed for some other gas must not be used for oxygen. Such use could result in a serious accident.

# **CAUTION**



Prevent foreign matter from entering the device. If rust, water droplets, oil mist, or dust in the pipes enters the device, measurement or control error or damage to the device might occur. If there is a possibility of foreign matter entering the device, provide an upstream filter, strainer or mist trap capable of eliminating foreign matter 0.1 $\mu$ m or greater in diameter. Be sure to inspect and replace the filter at regular intervals.



If this device is used to monitor gas flow rate to a burner, design pipes and instrumentation so that backfire will not damage the device.



This device is a precision instrument. Since impact might damage it, be careful not to drop or jolt it.



Do not use this device outside of the operating pressure range, or subject it to pressure above its pressure resistance. Doing so might damage it.



When making the pipe connections, fix the flange section of the pipe connector port in place, and turn the pipe to tighten.













When installing, fasten firmly to prevent vibration.



If using Rc connections, take care not to coat with too much sealant. Foreign matter or burrs in the pipes may cause measurement error.

# CAUTION

	<p>Before connecting pipes with Swagelok or VCR connections, check the instructions in the manual provided by the connecting joint manufacturer.</p> <p>When purchasing a connecting joint, use the following made by Swagelok Co., Ltd:</p> <p>1/4" Swagelok: SS-400-1-6STSC11 1/2" Swagelok: SS-810-1-8STSC11 1/4" VCR: SS-4-VCR-1-00032SC11 3/8" VCR: SS-8-VCR-1-8STSC11 or equivalent</p>
	<p>Observe the following when using this flowmeter for oxygen gas:</p> <ul style="list-style-type: none"><li>• Piping should be carried out by a specialist experienced in handling oxygen gas.</li><li>• Use oil-inhibited pipes and parts.</li><li>• Be sure to remove foreign matter, burrs, etc. from the pipes before connecting this flowmeter.</li><li>• Install a filter upstream of this device.</li></ul>
	<p>When carrying or installing this device, never hold it by the resin cover. Doing so could damage the cover, or the device could slip and fall, causing an injury.</p>
	<p>Mount this device horizontally. If it is mounted vertically, drift may occur when the flow rate is zero, resulting in erroneous measurement.</p>
	<p>Do not mount with the top surface facing down. Doing so might cause measurement error or device failure.</p>
	<p>When using a relay as the contact for integrated count reset input, use a relay designed for minute currents (with gold contacts). Otherwise, poor contact may cause faulty operation.</p>
	<p>If there is a risk of a power surge caused by lightning, use Azbil Corporation's SurgeNon to prevent possible fire or equipment failure.</p>
	<p>Be sure to check that the wiring is correct before turning the power on. Incorrect wiring could cause damage or faulty operation.</p>
	<p>Do not operate the keys with a mechanical pencil, screwdriver, or other sharp-tipped object. Doing so might cause faulty operation.</p>
	<p>Do not remove the resin cover and disassemble the pipe connections. Doing so might cause device failure.</p>
	<p>Make sure that the selected analog output type matches the input type of the receiving device. The output-receiving device could be damaged if the analog output type selection is incorrect.</p>

# Organization Used in This Manual

---

The manual is organized as shown below.

## **Chapter 1. INTRODUCTION**

Brief description of this device and its features, as well as a model selection guide.

## **Chapter 2. NAMES AND FUNCTIONS OF PARTS**

An illustration shows the part names and what the parts do.

## **Chapter 3. MOUNTING AND WIRING**

Details about installation, mounting, wiring and initial settings of this device.

## **Chapter 4. METHOD OF OPERATION**

How to set up the functions and parameters of this device.

## **Chapter 5. TROUBLESHOOTING**

How to diagnose and remedy problems that may occur during the operation of this device.

## **Chapter 6. SPECIFICATIONS**

Specifications and external dimensions of this device, and pressure loss information.

# Contents

---

## SAFETY PRECAUTIONS

Organization of This Manual

Conventions Used in This Manual

## Chapter 1. INTRODUCTION

■ Introduction .....	1
■ Features .....	1
■ Model selection guide .....	2

## Chapter 2. NAMES AND FUNCTIONS OF PARTS ..... 5

## Chapter 3. MOUNTING AND WIRING

■ Mounting .....	6
■ Pipes .....	8
■ Wiring .....	13

## Chapter 4. METHOD OF OPERATION

■ State transition diagrams .....	16
■ Function setup .....	17
■ Parameter setup .....	21
■ Display off mode .....	24
■ Integration .....	24
■ Resetting the count for integrated flow / integrated flow countdown ..	24
■ Event standby .....	24
■ Event ON delay .....	25
■ Flowrate zero calibration .....	25
■ Device behavior if the flow rate greatly exceeds the flow rate range ...	25

## Chapter 5. TROUBLESHOOTING

■ Remediying problems .....	26
-----------------------------	----





## Chapter 6. SPECIFICATIONS

■ General specifications .....	27
■ External dimensions .....	33
■ Pressure loss .....	39

# Conventions Used in This Manual

---

The following conventions are used in this manual:

-  **Handling Precautions:** Handling precautions indicate items that the user should pay attention to when handling a CMS Series flowmeter.
-  **Note:** Notes indicate information that might benefit the user.
- : This indicates the item or page that the user is requested to refer to.
- 03, 04:* This font is used to indicate output on the 7-segment display.
-  key: This indicates keys on the control panel.



# Chapter 1. INTRODUCTION

## ■ Introduction

CMS Gas Mass Flowmeters (models 9500, 0002, 0005, 0020, 0050, 0200 and 0500) use the  $\mu$ F (Micro Flow) sensor as their sensing element. The  $\mu$ F sensor is a thermal flow sensor made using proprietary technology. Integrating this ultra-minute mass flow sensor with high-grade channel design technology has achieved high accuracy and high rangeability.

## ■ Features

- Incorporates the  $\mu$ F sensor, made possible by silicon micro-machining and thin-film technologies. Measuring a mere 1.7mm square and 0.5mm thick, the  $\mu$ F sensor exhibits high sensitivity and quick response.
- Since this device is a mass flowmeter, it is not influenced by temperature or pressure.
- Features a high accuracy of  $\pm 3\%$  rdg\* (varies depending on the model) and a high rangeability of 100:1.

Model	Range of measurement
CMS9500	5 to 500 mL/min (standard)
CMS0002	0.02 to 2 L/min (standard)
CMS0005	0.05 to 5 L/min (standard)
CMS0020	0.2 to 20 L/min (standard)
CMS0050	0.5 to 50 L/min (standard)
CMS0200	2 to 200 L/min (standard)
CMS0500	5 to 500 L/min (standard)

- Models have extensive functions to suit a wide range of applications: analog output, event output, integrated flow/integrated countdown display, output scaling, gas type selection, totalizer pulse output, external contact input (for integrated count reset), and flow rate data serial output.
- Straight pipe sections are not required before and after this device (in case of a same diameter pipe).

\* Rdg (reading) pertains to accuracy expressed as a percentage of the indicated value. The accuracy varies depending on the model. For details see chapter 6, SPECIFICATIONS.

■ Model selection guide

The chart below shows the model numbering system for this flowmeter.

● SUS model

Basic model No.	Flow rate range	Model type	Material	Connection method	Gas type	Output	Optional function				Appended No.	Description
							1	2	3	4		
CMS												Gas Mass Flowmeter
	9500											Standard flow rate range 0 to 500mL/min (standard)* <sup>1</sup>
	0002											Standard flow rate range 0 to 2L/min (standard)* <sup>1</sup>
	0005											Standard flow rate range 0 to 5L/min (standard)* <sup>1</sup>
	0020											Standard flow rate range 0 to 20L/min (standard)* <sup>1</sup>
	0050											Standard flow rate range 0 to 50L/min (standard)* <sup>1</sup>
	0200											Standard flow rate range 0 to 200L/min (standard)* <sup>1</sup>
	0500											Standard flow rate range 0 to 500L/min (standard)* <sup>1</sup>
		B										Model with display
			S									SUS (for details, refer to the specifications)
				R								Rc1/2" (CMS0200/0500)
					N							Rc1/4" (CMS9500/0002/0005/0020/0050)
					S							Air/nitrogen (Setting can be changed to standard supported gases* <sup>2</sup> )
						S						Oxygen* <sup>3</sup>
							2					Output 0 to 5Vdc/1 to 5Vdc/4 to 20mA
								0				Without optional function
									0			Without optional function
										0		Without oil-inhibited treatment
											1	Gas-contacting parts treated to be oil-inhibiting
											0	Without optional function
											D	Inspection certificate provided
											Y	Traceability certification provided
											0	Product version

\*1. L/min (standard) and mL/min (standard) indicate flow rates converted to 20°C, 101.325kPa (atmospheric pressure).

\*2. The factory setting is air/nitrogen.

It can be changed to any of the gas types shown below. When gas type is changed, sometimes the flow rate range changes. Consequently, when selecting a gas type, make sure to check the "maximum measurable flow rate for each gas type" in the specifications of the corresponding model.

Applicable gas types: air/nitrogen, argon, carbon dioxide (CO<sub>2</sub>), oxygen (gas type: S only), natural gas 13A (a gas produced from LNG, of which 88% is methane), methane 100%, propane 100%, butane

\*3. When oxygen (gas type: S) is selected, make sure to specify "1: Gas-contacting parts treated to be oil-inhibiting" under Optional function. Be aware that use with oxygen is possible only for model numbers specially designated for oxygen.

● SUS 316 model

Basic model No.	Flow rate range	Model type	Material	Connection method	Gas type	Out-put	Optional function				Appended No.	Description	
							1	2	3	4			
CMS												Gas Mass Flowmeter	
	9500											Standard flow rate range 0 to 500mL/min (standard)*1	
	0002											Standard flow rate range 0 to 2L/min (standard)*1	
	0005											Standard flow rate range 0 to 5L/min (standard)*1	
	0020											Standard flow rate range 0 to 20L/min (standard)*1	
	0050											Standard flow rate range 0 to 50L/min (standard)*1	
	0200											Standard flow rate range 0 to 200L/min (standard)*1	
	0500											Standard flow rate range 0 to 500L/min (standard)*1	
			B										Model with display
				T									Stainless steel (SUS316)
				U								UNF connection CMS0200/0500:3/4-16 UNF CMS9500/0002/0005/0020/0050: 9/16-18 UNF	
				T								Rc fitting connection CMS0200/0500:Rc 1/2" CMS9500/0002/0005/0020/0050:Rc 1/4"	
				S								Swl connection CMS0200/0500:1/2" Swagelok CMS9500/0002/0005/0020/0050:1/4" Swagelok	
				V								VCR connection CMS0200/0500:3/8" VCR or equivalent CMS9500/0002/0005/0020/0050:1/4" VCR	
				N								Air/nitrogen (setting can be changed to standard supported gases*2)	
				S								Oxygen*3	
						2						Output 0 to 5Vdc/1 to 5Vdc/4 to 20mA	
						0						Without optional function	
						1						Model with RS-485 communications function	
							0					Without optional function	
								0				Without oil-inhibited treatment	
								1				Gas-contacting parts treated to be oil-inhibiting	
								0				Without optional function	
								D				Inspection certificate provided	
								Y				Traceability certification provided	
									0			Product version	

\*1. L/min (standard) and mL/min (standard) indicate flow rates converted to 20°C, 101.325kPa (atmospheric pressure).

\*2. The factory setting is air/nitrogen.

It can be changed to any of the gas types shown below. When gas type is changed, sometimes the flow rate range changes. Consequently, when selecting a gas type, make sure to check the "maximum measurable flow rate for each gas type" in the specifications of the corresponding model.

Applicable gas types: air/nitrogen, argon, carbon dioxide (CO<sub>2</sub>), oxygen (gas type: S only), natural gas 13A (a gas produced from LNG, of which 88% is methane), methane 100%, propane 100%, butane

\*3. When oxygen (gas type: S) is selected, make sure to specify "1: Gas-contacting parts treated to be oil-inhibiting" under Optional function. Be aware that use with oxygen is possible only for model numbers specially designated for oxygen.

● **Accessories (sold separately)**

Item	Model number	Remarks
Harness with dedicated connector (One harness is required for one CMS unit.)	81446594-005	Harness (2m) for model without communications - plain wire termination
	81446594-006	Harness (5m) for model without communications - plain wire termination
	81446594-007	Harness (2m) for model with communications - M3.5 Y-terminals
	81446594-008	Harness (5m) for model with communications - M3.5 Y-terminals
Mounting bracket	81446628-001	For CMS9500/0002/0005/0020/0050
	81446721-001	For CMS0200
	81446856-001	For CMS0500
AC adapter	81446957-001	Operating temperature range: 0 to 40°C
Harness connecting AC adapter	81446594-030	

● **Replacement parts**

Item	Model number	Remarks
Joint for maintenance (This joint is intended to replace a damaged one on an SUS316 model only.)	81446834-001	1/4" Rc joint (2)
	81446834-002	1/2" Rc joint (2)
	81446833-001	1/4" Swagelok joint (2)
	81446833-002	1/2" Swagelok joint (2)
	81446895-001	1/4" VCR joint (2)
	81446895-002	3/8" VCR joint (2)



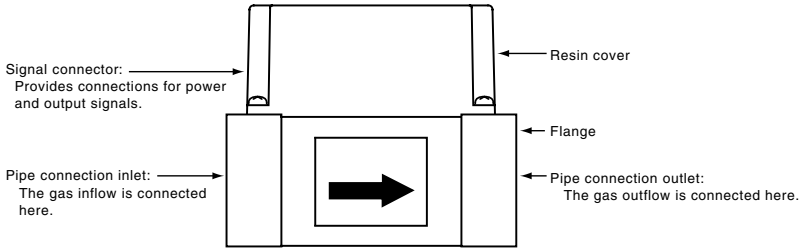
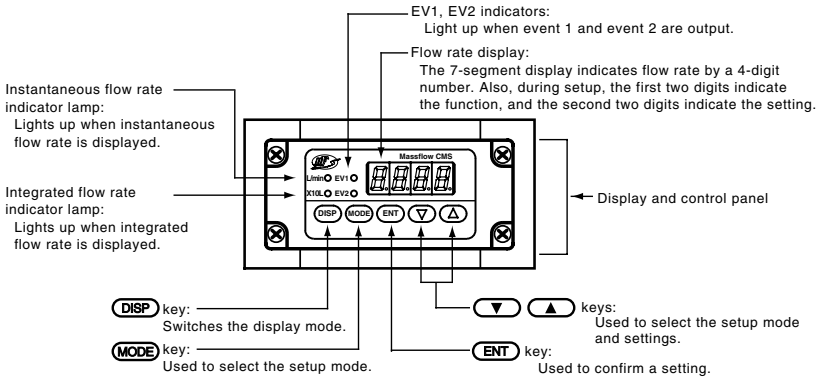

# Chapter 2. NAMES AND FUNCTIONS OF PARTS

Names and functions of external parts are given below.











# Chapter 3. MOUNTING AND WIRING

## WARNING

-  If this device is used for a flammable gas, mount it on the upstream side of the safety shutoff valve. If somehow air or oxygen gets into the pipes and an explosive mixture is produced, and if the sensor should make a spark due to lightning or some other reason, the gas mixture in the pipes could explode.
-  Never allow a gas that is within explosive limits to enter this device. Doing so could cause an explosion.
-  If a model designed for use with oxygen has been used for other gases, do not use it again for oxygen. Doing so could cause a serious accident.
-  A model designed for some other gas must not be used for oxygen. Such use could result in a serious accident.

## CAUTION

-  Prevent foreign matter from entering the device. If rust, water droplets, oil mist, or dust in the pipes enters the device, measurement or control error or damage to the device might occur. If there is a possibility of foreign matter entering the device, provide an upstream filter, strainer or mist trap capable of eliminating foreign matter 0.1 $\mu$ m or greater in diameter. Be sure to inspect and replace the filter at regular intervals.
-  If this device is used to monitor gas flow rate to a burner, design pipes and instrumentation so that backfire will not damage the device.
-  This device is a precision instrument. Since impact might damage it, be careful not to drop or jolt it.
-  Do not use this device outside of the operating pressure range, or subject it to pressure above its pressure resistance. Doing so might damage it.
-  When connecting piping, fasten the flange section of the pipe connector port, and turn the pipe side to connect.
-  When installing, fasten firmly to prevent vibration.
-  If using Rc connections, take care not to coat with too much sealant. Foreign matter or burrs in the pipes may cause measurement error.
-  Before connecting pipes with Swagelok or VCR connections, check the instructions in the manual provided by the connecting joint manufacturer.  
When purchasing a connecting joint, use the following made by Swagelok Co., Ltd:
  - 1/4" Swagelok: SS-400-1-6STSC11
  - 1/2" Swagelok: SS-810-1-8STSC11
  - 1/4" VCR: SS-4-VCR-1-00032SC11
  - 3/8" VCR: SS-8-VCR-1-8STSC11 or equivalent

 **CAUTION**

Do not remove the resin cover and disassemble pipe connections. Doing so might cause malfunction.



When carrying or installing this device, never hold it by the resin cover. Doing so could damage the cover, or the device could slip and fall, causing an injury.

## ■ Mounting

### ● Installation site

Avoid mounting this device in the following locations:

- Where ambient temperature falls below 0°C or rises above 50°C
- Where ambient humidity exceeds 90% RH
- Locations subject to sudden changes in temperature and condensation
- In corrosive or flammable gas atmospheres
- Where there are large amounts of conductive substances (e.g. dust, salt or iron dust), water droplets, oil mist, or organic solvents.
- Locations subject to vibration or shock
- Locations subject to direct sunlight
- Locations splashed by water or rain
- Locations subject to splashing by fluids (e.g. oil, chemicals)
- Locations subject to strong magnetic or electrical fields

## ■ Pipes

### ● Precautions for piping installation

This device is a precision instrument. If foreign matter such as dust, oil mist or water enters the device, it may cause measurement error or faulty operation. When installing piping, be sure to follow the procedures below to prevent foreign matter from entering the device.

1. Before installing the device, be sure to flush the upstream and downstream piping thoroughly to remove welding fume particulate and dust.
2. Be sure to wipe the inside of the pipe to be directly connected to this device.
3. After the above two operations are complete, check to be sure that there is no welding fume particulate or dust, and then install the device.

### ⓘ Handling Precautions

- If foreign matter cannot be fully eliminated by flushing or wiping, or if the regular presence of foreign matter can be expected, be sure to install a filter. If dust, oil or moisture adheres to the metallic mesh or to the Micro Flow sensor chip, measurement error or device failure may result.

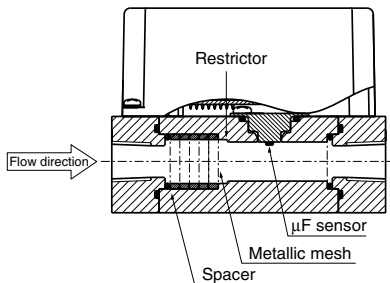

### ● Filter installation

For a dedicated filter, contact the azbil Group.

For applications with compressed air or propane, which regularly contain oil mist, or applications where rust in the piping is expected, be sure to install a filter. Recommended type:

Name : MFF100 series

Specifications: For details, refer to "Lineup of Mist Separators and Filters for Micro Flow Sensors," Azbil Corporation specifications sheet CP-SS-1824E.





● **Straight pipe section**

In case of different diameter piping (diameters A and B are different), a straight pipe section is required.

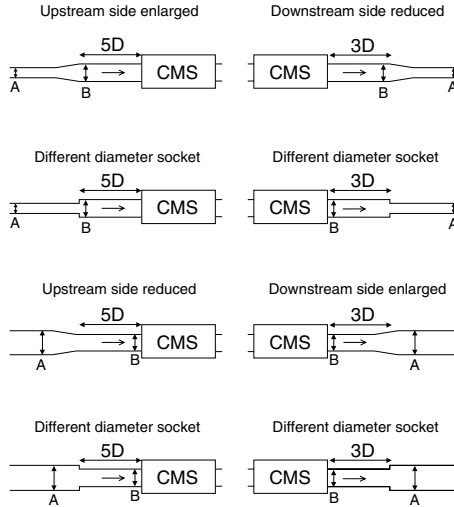

D indicates the connecting port size.  
 CMS0200/0500: 12mm  
 CMS9500/0002/0005/0020/0050: 6mm

In case of same diameter piping (diameters A and B are the same), a straight pipe section is not required.

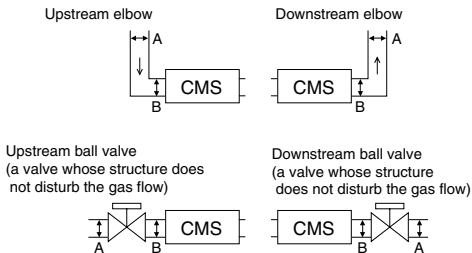

**Handling Precautions**

- When using a valve that disturbs the gas flow, such as a butterfly valve, put a 5D straight pipe section between the CMS and the valve.

● Rc connection

- Coating sealant

Coat with an appropriate amount of sealant. Do not coat the top two threads of the screw. Remove any dirt or burrs from inside the pipes.

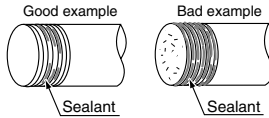

● UNF connection

- Connect pipes

Hold the connection port flange with a wrench while connecting the piping.

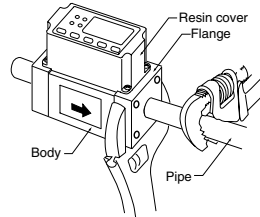

- Connecting Joints

Hold the connection port flange with a wrench while connecting joints.

❗ **Handling Precautions**

- Do not grip and turn the body. Doing so might damage the body or cause leakage.
- When connecting the piping, do not hold the flowmeter by the resin cover. Doing so might damage the cover.
- Observe the specified tightening torque.

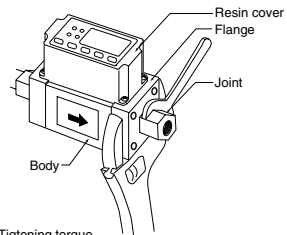

Tightening torque  
 CMS9500/0002/0005/0020/0050: 40 to 45N\*m  
 CMS0200/0500: 50 to 60N\*m

● Gas flow

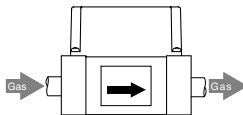

❗ **Handling Precautions**

- Gas must flow through the meter in the direction of the arrow on the side of the flow channel. Flow in the opposite direction cannot be measured accurately.

● Mounting the flowmeter

**! CAUTION**



Mount this device horizontally. If it is mounted vertically, drift may occur when the flow rate is zero, resulting in erroneous measurement.



Do not mount with the top surface facing down. Doing so might cause measurement error or device failure.

• Mounting Position

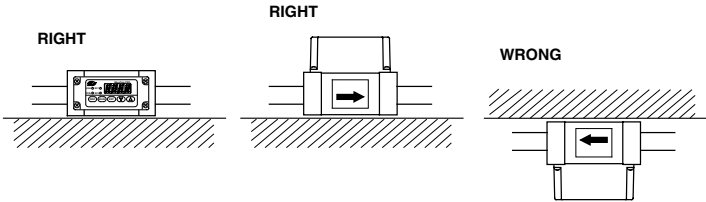

• Mounting

There are two ways of mounting the flowmeter:

1. Fasten it with two or four screws (depending on the model) from the rear side using the mounting screw holes on the bottom of the device.

Hole dimensions when mounted directly

Unit: mm

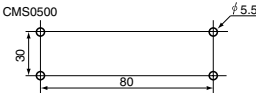
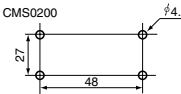
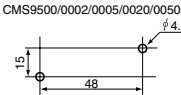

2. Using the dedicated mounting bracket (optional), fasten it from the front using four screws.

Mounting bracket model number:

for CMS9500/0002/0005/0020/0050: 81446628-001

for CMS0200: 81446721-001

for CMS0500: 81446856-001

Hole dimensions when mounting bracket is used

Unit: mm

- CMS9500/0002/0005/0020/0050

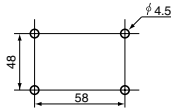

- CMS0200

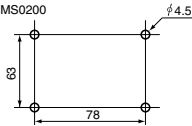

- CMS0500

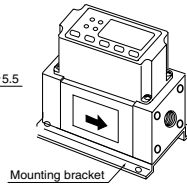
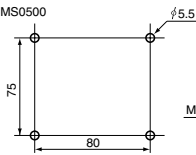

## ■ Wiring

### ⚠ CAUTION

- ❗ When using a relay as the contact for integrated count reset input, use a relay designed for low current (with gold contacts). Otherwise, poor contact may cause faulty operation.
- ❗ If there is a risk of a power surge caused by lightning, use Azbil Corporation's SurgeNon to prevent possible fire or equipment failure.
- ❗ Be sure to check that the wiring is correct before turning the power on. Incorrect wiring could cause damage or faulty operation.

We recommend using a harness (sold separately) with a dedicated connector.

### ● Connector pin layout

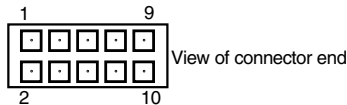

Mating connector:

DF11-10DS-2C, made by Hirose Electric Co., Ltd.

Item	Model number	Remarks
Harness with dedicated connector (One harness is required for one CMS unit.)	81446594-005	Harness (2m) for model without communications – plain wire termination
	81446594-006	Harness (5m) for model without communications – plain wire termination
	81446594-007	Harness (2m) for model with communications – M3.5 Y-terminals
	81446594-008	Harness (5m) for model with communications – M3.5 Y-terminals

● Connector signal names

Pin No.	Name	Description	Remarks
1	DC OUT +	Instantaneous flow rate output +	
2	DC OUT -	Instantaneous flow rate output -	
3	V +	Power + (12 to 24Vdc)	
4	GND	Power GND	
5	DA	For RS-485 communications	Connect only when RS-485 model is used.
6	DB		
7	D IN	Integrated count reset input	
8	EV 2	Event output 2 / Totalizer pulse output	
9	EV 1	Event output 1 / Serial data output	
10	EV COM/SG	Event output common/SG for RS-485	

● Connection example

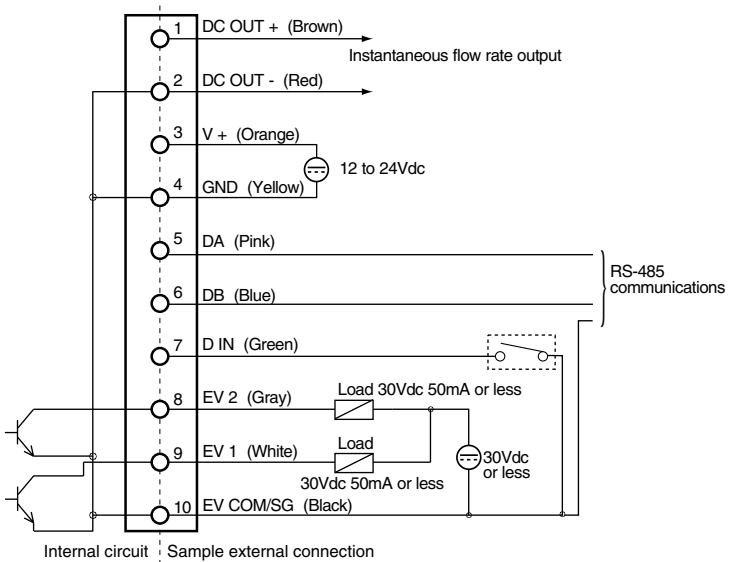

! Handling Precautions

- Power source GND, instantaneous flow rate output (-), and event output common lines are all connected inside this device. If these lines are connected to an external device through a common power supply, interference will cause device failure or faulty operation.
- Take care that the event output does not exceed the output rating of this device. If a relay is used, the coil should have a built-in surge absorption diode. Otherwise device failure could occur.

● Connection of totalizer pulse output to a counter.

- Non-voltage input type

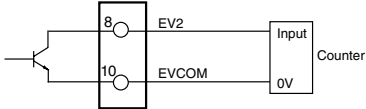

- Voltage input type

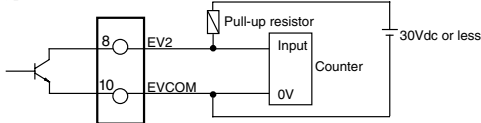

● Use of flow rate serial data output

- Connection example

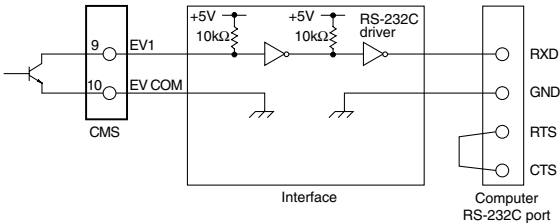

- Communications protocol

Currently displayed instantaneous flow rate data and totalizer flow data is sent as ASCII code. "F" and the instantaneous flow rate data is sent first, followed by "T" and the totalizer flow data.

Example: The instantaneous flow rate is 100. L/min (standard), and the totalizer flow is 100 x 10L.

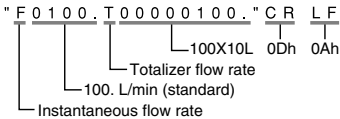

- Communications specifications

Item	Description
Communications system	RS-232C, start-stop transmission
Transmission speed	9600bps
Character length	8 bits
Stop bit	2
Parity	None
Data transmission cycle	100±10ms

# Chapter 4. METHOD OF OPERATION

## ⚠ CAUTION



Do not operate the keys with a mechanical pencil, screwdriver, or other sharp-tipped object. Doing so might cause faulty operation.



Make sure that the selected analog output type matches the input type of the receiving device. The output-receiving device could be damaged if the analog output type selection is incorrect.

### ■ State transition diagrams

Upon power-up, with the factory settings, the instantaneous flow rate is displayed and the instantaneous flow rate indicator lamp lights up.

The diagram below shows the relationship between a change in mode and the display (in the case of CMS0500).

If the measurement mode (function setup item 02) is set to 01 or 02, the last four digits of the integrated flow or integrated flow countdown can be displayed by pressing the **DISP** key while the instantaneous flow rate is displayed. Pressing **DISP** again displays the first four digits of the integrated flow or integrated flow countdown. Pressing **DISP** again returns the display to the instantaneous flow rate.

When the power is turned OFF and then back ON again, the display state before the power was turned OFF resumes.

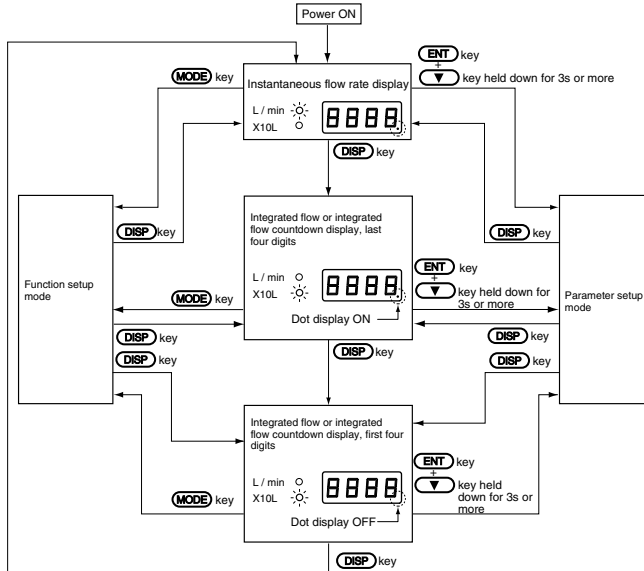

### ⓘ Handling Precautions

- If the **MODE** key is pressed during setup, the setting returns to its previous value.
- Leave the device powered up for about 30min before use to allow it to stabilize.



## ■ Function setup

To enter the setup mode, press the **MODE** key. The first two digits on the display blink. The first two digits identify the function setup item, and the second two digits indicate the setting for that item.

- Pressing the **▼** key moves the display to the next setup item. Pressing the **▲** key moves to the previous setup item.
- Pressing **▼** key when  $t2$  is displayed changes the display to  $t1$ .<sup>\*2</sup>

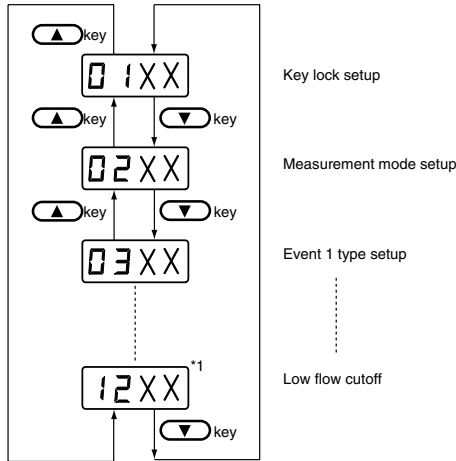





- Pressing **▲** key when  $t1$  is displayed changes the display to  $t2$ .<sup>\*2</sup>
- When the first two digits display the desired setup item, press the **ENT** key while it is blinking. This selects the setup item, and the second two digits blink.
- Press the **▲** and **▼** keys to select the desired setting, and then press **ENT** key. All four digits light up.
- Check that the item and the setting are correct.
- The table on the following pages shows all the functions and settings.

\*1. Models with the communications function display  $30$ ,  $31$ , and  $32$  in that order after  $t2$ .

\*2. For models with a communications function, the number is  $32$ .

## ● Function setup menu

Item	Function	Setting	Setting description	Factory setting	Remarks
01	Key lock	00 01	Key lock disabled Lock ON	00	When key lock is ON, other function and parameter settings can be checked, but cannot be changed.
02	Measurement mode	00 01 02	Only instantaneous flow rate is measured. Instantaneous flow rate and integrated flow are measured. Instantaneous flow rate and integrated flow countdown are measured.	01	
03	Event 1 type (EV1)	00 01 02 03 04 05 06	Not used Instantaneous flow rate upper limit value Instantaneous flow rate lower limit value Integrated flow count up Reverse integrated flow count down Flow rate data serial output Error output	00	Integrated flow count, integrated flow countdown, and totalizer pulse output settings are effective only when function setting 02 is set to 01 or 02.
04	Event 2 type (EV2)	00 01 02 03 04 05 06 07	Not used Instantaneous flow rate upper limit value Instantaneous flow rate lower limit value Integrated flow count up Reverse integrated flow count down Totalizer pulse output rate 1(*1) Totalizer pulse output rate 2(*1) Totalizer pulse output rate 3(*1)	00	Integrated flow count and integrated flow countdown cannot be set simultaneously.
05	ON delay setting (EV1)	00 01	Disabled ON	00	Valid only when function 03 is set to 01 or 02.
06	ON delay setting (EV2)	00 01	Disabled ON	00	Valid only when function 04 is set to 01 or 02.
07	Event standby setting	00 01	Disabled ON	00	Valid only when function 03 or 04 is set to 02.  Page 24
08	Gas type selection	00 01 02 03 04 05 06 07 08 11	Air/nitrogen Argon Carbon dioxide (CO <sub>2</sub> ) Oxygen City gas 13A (46MJ) Methane 100% Propane 100% Butane User specified City gas 13A (45MJ)	00	You can select 03 only when gas type S (oxygen) is specified. When an other gas type is specified, you can select from among 00, 01, 02, 04, 05, 06, 07, 08 and 11. When gas type is changed, sometimes flowrate measurement rate changed.  Page 28
09	Analog output scaling	00 01 02 03 04	See the footnote on the right page *2	00	For details,  Page 20.
10	Analog output type selection	00 01 02	0 to 5V 1 to 5V 4 to 20mA	00	Make sure that the selected analog output type matches the input type of the receiving device.
11	Reference temperature	00 to 35	0 to 35°C (in 1°C intervals), 101.325kPa (1atm) standard	20	

Item	Function	Setting	Setting description	Factory setting	Remarks
12	Low flow cutoff	00 01 02 03 04	No low flow cutoff Cutoff below the rated minimum display * 1% FS 2.5% FS 5% FS	01	If gas type (function setup 08) is set to "user specified"(08), the low flow cutoff is the amount set here multiplied by CF, the gas type conversion (parameter setup P-08).  * The minimum display may vary depending on the model.  Page 30
30	Communications address	00 01 to 99	Communication function disabled Communication address	00	Only for models with RS-485 communications.
31	Transmission speed	00 01 02	9600bps 4800bps 2400bps	00	Only for models with RS-485 communications.
32	Data format	00 01	8 data bits, even parity, 1 stop bit 8 data bits, no parity, 2 stop bits	00	Only for models with RS-485 communications.

\*1 Totalizer pulse output rate

Item	Function	Setting	CMS9500	CMS0002/0005	CMS0020/0050	CMS0200/0500
04	Event output 2 (EV2)	05 06 07	10mL/pulse 100mL/pulse 1000mL/pulse		1L/pulse 10L/pulse 100L/pulse	10L/pulse 100L/pulse 1000L/pulse

\*2 Analog output scaling

Item	Function	Setting	CMS9500	CMS0002	CMS0005	CMS0020	CMS0050	CMS0200	CMS0500
09	Analog output scaling	00 01 02 03 04	0 to 500 0 to 300 0 to 200 0 to 100 Desired scaling	0 to 2 0 to 1 0 to 0.5 0 to 0.2 Desired scaling	0 to 5 0 to 3 0 to 2 0 to 1 Desired scaling	0 to 20 0 to 10 0 to 5 0 to 2 Desired scaling	0 to 50 0 to 30 0 to 20 0 to 10 Desired scaling	0 to 200 0 to 100 0 to 50 0 to 20 Desired scaling	0 to 500 0 to 300 0 to 200 0 to 100 Desired scaling

The unit for the CMS9500 is mL/min. For other models the unit is L/min.

**\* Analog output scaling**

Analog output can be scaled as shown in the preceding table.

If gas type selection (function setup 08) is changed, the measurable flow rate range changes as specified on page 32 ("Maximum measurable flow rate for each gas type"). However, scaling according to the analog output scaling setting will be applied to the output regardless of what gas type is selected.

Example: For the CMS0050, if gas type (function setup 08) is changed to 02 (carbon dioxide), the measurable flow rate range changes to 0 to 25 L/min. If scaling is set to 01 (0 to 30 L/min), the 0 to 5V output will be as shown below.

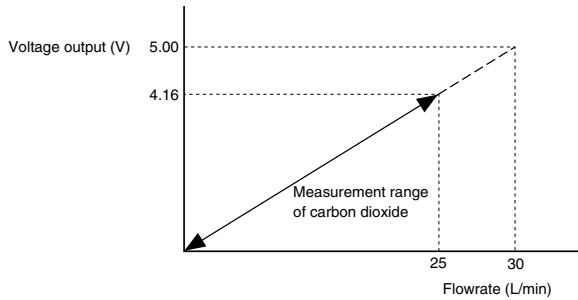

If the output type is 0 to 5V, and if output scaling is used, the maximum output voltage can be calculated as follows.

- When gas types 00 to 07 or 11 are selected

$$\frac{\text{Max. measurable flow rate for the gas}}{\text{Scaling upper limit value}} \times 5V$$

- When gas type 08 is selected

$$\frac{\text{Max. measurable flow rate for the gas}}{\text{Scaling upper limit value}} \times \frac{1}{\text{Gas type conversion factor}} \times 5V$$

For the maximum measurable flow rate for each gas, see page 28.

The gas type conversion factor is set in parameter setup; see pages 21-24.

## ■ Parameter setup

If the key lock function is ON, parameter settings cannot be changed.

To enter the parameter setup mode, hold down the **ENT** and **▼** keys simultaneously for at least three seconds. If conditions do not allow parameter setup, "P---" is displayed.

Otherwise, in parameter setup mode,  $P-***$  is displayed. The last two digits identify the parameter setup item.

Pressing the **▼** key moves the display to the next setup item. Pressing the **▲** key moves to the previous setup item.

The currently set value for that item is displayed.

If the **ENT** key is pressed again, the last digit blinks.



If you press the **MODE** key, the blinking cursor moves to the left. To change the setting at each of these digits, use the **▲** and **▼** keys.

To change the setting to the displayed value, press the **ENT** key.

If event type (function setup  $03$  or  $04$ ) has been set to  $03$  or  $04$ , the setting of 8-digit numbers is necessary in  $P-01$ ,  $02$  and  $07$ . To do this, switch between the first 4 digits and the last 4 digits as shown below.

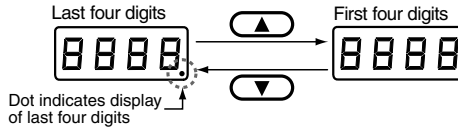

Whether parameters  $P-01$  to  $P-09$  are displayed for setup depends upon the function settings. The following tables show the parameters and the necessary function settings.

## ● CMS9500

Parameter	Description	Factory setting	Setting range	Conditions for display (function settings)
P-01	Event output 1 setting value (EV1)	0.	0 to 9999 (mL/min)	Item 03 is 01 or 02
		00000000.	0 to 99999999 (X 10mL)	Item 03 is 03 or 04
P-02	Event output 2 setting value (EV2)	0.	0 to 9999 (mL/min)	Item 04 is 01 or 02
		00000000.	0 to 99999999 (X 10mL)	Item 04 is 03 or 04
P-03	EV1 hysteresis	50.	0 to 100 (mL/min)	Item 03 is 01 or 02
P-04	EV2 hysteresis	50.	0 to 100 (mL/min)	Item 04 is 01 or 02
P-05	EV1 ON delay	0	0 to 60 (s)	Item 03 is 01 or 02
P-06	EV2 ON delay	0	0 to 60 (s)	Item 04 is 01 or 02
P-07	Initial value for integrated flow countdown	00000000.	0 to 99999999 (X 10mL)	Item 02 is 02
P-08	Gas type conversion factor	1.000	0.100 to 8.000	Item 08 is 08
P-09	Analog output scaling	100	10 to 250 (%)	Item 09 is 04

## ● CMS0002/0005

Parameter	Description	Factory setting	Setting range	Conditions for display (function settings)
P-01	Event output 1 setting value (EV1)		0.000 to 99.99 (L/min)* <sup>1</sup>	Item 03 is 01 or 02
		00000000.	0 to 99999999 (L)	Item 03 is 03 or 04
P-02	Event output 2 setting value (EV2)		0.000 to 99.99 (L/min)* <sup>1</sup>	Item 04 is 01 or 02
		00000000.	0 to 99999999 (L)	Item 04 is 03 or 04
P-03	EV1 hysteresis	0.50* <sup>2</sup>	0 to 1.00 (L/min)* <sup>2</sup>	Item 03 is 01 or 02
P-04	EV2 hysteresis* <sup>3</sup>	0.50* <sup>2</sup>	0 to 1.00 (L/min)* <sup>2</sup>	Item 04 is 01 or 02
P-05	EV1 ON delay	0	0 to 60 (s)	Item 03 is 01 or 02
P-06	EV2 ON delay	0	0 to 60 (s)	Item 04 is 01 or 02
P-07	Initial value for integrated flow countdown	00000000.	00000000 to 99999999 (L)	Item 02 is 02
P-08	Gas type conversion factor	1.000	0.100 to 8.000	Item 08 is 08
P-09	Analog output scaling	100	10 to 250 (%)	Item 09 is 04

● CMS0020/0050

Parameter	Description	Factory setting	Setting range	Conditions for display (function settings)
P-01	Event output 1 setting value (EV1)	0.0	0 to 999.9 (L/min(standard))*1	Item 03 is 01 or 02
		00000000.	0 to 99999999 (L)	Item 03 is 03 or 04
P-02	Event output 2 setting value (EV2)	0.0	0 to 999.9 (L/min(standard))*1	Item 04 is 01 or 02
		00000000.	0 to 99999999 (L)	Item 04 is 03 or 04
P-03	EV1 hysteresis	5.0 *2	0 to 10.0 (L/min)*2	Item 03 is 01 or 02
P-04	EV2 hysteresis	5.0 *2	0 to 10.0 (L/min)*2	Item 04 is 01 or 02
P-05	EV1 ON delay	0	0 to 60 (s)	Item 03 is 01 or 02
P-06	EV2 ON delay	0	0 to 60 (s)	Item 04 is 01 or 02
P-07	Initial value for integrated flow countdown	00000000.	0 to 99999999 (L)	Item 02 is 02
P-08	Gas type conversion factor	1.000	0.100 to 8.000	Item 08 is 08
P-09	Analog output scaling	100	10 to 250 (%)	Item 09 is 04

● CMS0200/0500

Parameter	Description	Factory setting	Setting range	Conditions for display (function settings)
P-01	Event output 1 setting value (EV1)	0.	0 to 9999 (L/min)*1	Item 03 is 01 or 02
		00000000.	0 to 99999999 (X 10L)	Item 03 is 03 or 04
P-02	Event output 2 setting value (EV2)	0.	0 to 9999 (L/min)*1	Item 04 is 01 or 02
		00000000.	0 to 99999999 (X 10L)	Item 04 is 03 or 04
P-03	EV1 hysteresis	50.*2	0 to 100 (L/min)*2	Item 03 is 01 or 02
P-04	EV2 hysteresis	50.*2	0 to 100 (L/min)*2	Item 04 is 01 or 02
P-05	EV1 ON delay	0	0 to 60 (s)	Item 03 is 01 or 02
P-06	EV2 ON delay	0	0 to 60 (s)	Item 04 is 01 or 02
P-07	Initial value for integrated flow countdown	00000000.	0 to 99999999 (X 10L)	Item 02 is 02
P-08	Gas type conversion factor	1.000	0.100 to 8.000	Item 08 is 08
P-09	Analog output scaling	100	10 to 250 (%)	Item 09 is 04

\*1 If user-specified gas type is selected in function setup 08, and if the gas type conversion factor (P-08) is set between 0.100 and 0.499, the range is:

CMS0002	0.000 to 0.995 (in 0.005 increments)
CMS0020	0.00 to 9.95 (in 0.05 increments)
CMS0200	0.0 to 99.5 (in 0.5 increments)

\*2 If user-specified gas type is selected in function setup 08, and if the gas type conversion factor (P-08) is set between 0.100 and 0.499, the range is:

	Factory setting	Setting range
CMS0002	0.05	0.000 to 0.100 (in 0.005 increments)
CMS0020	0.5	0.00 to 1.00 (in 0.05 increments)
CMS0200	5.0	0.0 to 10.0 (in 0.5 increments)

**!** Handling Precaution

- Set a value for event output that is within the measurable range.

■ **Display OFF mode**

If the **DISP** key is held down for at least three seconds, all display is turned off except for the instantaneous flow rate indicator lamp, which blinks.

■ **Totalization**

If integrated flow exceeds **99999999**, the count returns to **0** and counting continues. When this happens, event output for integrated flow remains OFF until the set value is reached again.

If the integrated flow countdown reaches **0**, counting stops.

■ **Resetting the count for integrated flow / integrated flow countdown**

To reset the count, hold down the **▲** and **▼** keys simultaneously for at least one second while the integrated amount or integrated countdown amount is displayed. The integrated flow count is reset to 0, and the countdown is reset to the default. After reset counting up or counting down resumes.

■ **Event standby**

Event standby operates only on the basis of the instantaneous flow rate lower limit. This function prevents an erroneous low flow alarm when there is no gas flow because the device has just started up, for example. After the power is turned ON, and until the instantaneous flow rate has exceeded the value set for the event lower limit, there is no event action. After the instantaneous flow lower limit has been exceeded once, event action operates normally.

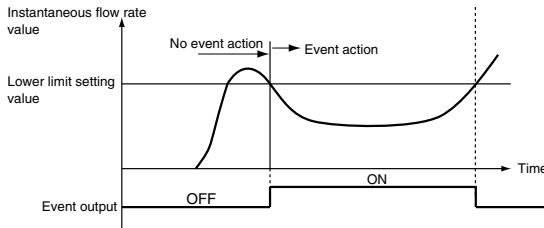



■ **Event ON delay**

ON delay times (0 to 60s) can be set for both events 1 and 2.

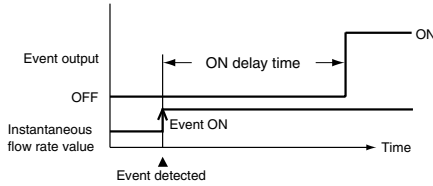

■ **Flowrate zero calibration**

If the indicated flow rate is not zero even though the actual flow rate is zero, and it seems possible that the sensor's zero point may have shifted, try the following procedure for flow rate zero calibration.

- (1) Display the flow rate or integrated flow amount.
- (2) Press and hold the **ENT** key.
- (3) After approx. 10s have elapsed, **0.000** blinks on the flow rate display.
- (4) Press and hold **ENT** again.
- (5) After approx. 1 second, **0.000** stops blinking and remains lit. The amount of sensor output at this moment is now treated as zero.
- (6) Press **DISP** key to return to the instantaneous flow rate or integrated flow display.

! **Handling Precautions**

- Use flow rate zero calibration only after ensuring that the flow path contains only the gas being measured, and after stabilizing the actual flow rate at zero.

■ **Device behavior if the flow rate greatly exceeds the flow rate range**

If the flow rate exceeds the upper limit, the display might no longer indicate the correct rate, and the output signal might not be correct. Be sure to use within the specified flow rate range.

If the flow rate exceeds 120% of the upper limit, the main display alternately indicates flow rate and **RLM!**. If the flow rate increases further, the **RLM!** indication goes out and a flow rate lower than the actual flow rate is displayed. Be careful, because if the flow rate suddenly becomes excessive, **RLM!** may not be displayed.

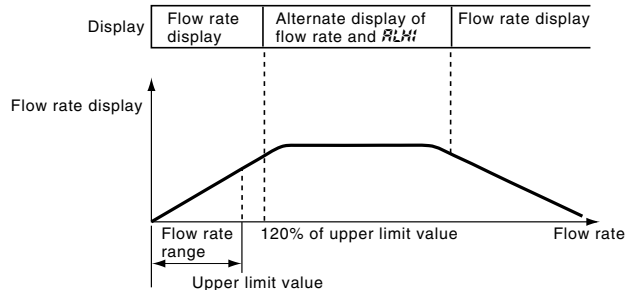

# Chapter 5. TROUBLESHOOTING

## ■ Remediating problems

Refer to the following table if a problem occurs:

Problem	Countermeasure
Nothing on the display.	<ul style="list-style-type: none"> <li>• Make sure that power with the correct voltage and polarity is being supplied.</li> <li>• Make sure that connectors are correctly connected.</li> </ul>
<i>RLH</i> <i>i</i> is displayed.	The instantaneous flow rate has exceeded 120% of the measurement range. Reduce the flow rate so that it is within range, and normal operation will automatically resume.
<i>Err</i> <i>i</i> is displayed.	Sensor error <ul style="list-style-type: none"> <li>• Make sure that gas is not flowing back, or the gas flow direction is not reversed.</li> <li>• Make sure that an excess current is not flowing.</li> </ul> If the unit is not restored after turning the power OFF, contact the azbil Group and ask for repair.
<i>Err</i> <i>2</i> is displayed.	Memory data error Contact the azbil Group and ask for repair.
Signal is output even though the flowrate should be zero.	<ul style="list-style-type: none"> <li>• Check the piping for any gas leaks.</li> <li>• Check the wiring to make sure that it is correct.</li> <li>• If the device is mounted vertically, mount it horizontally. If it seems possible that the sensor's zero point has shifted, try flow rate zero calibration (page 25).</li> </ul>
Flow rate has deviated excessively.	<ul style="list-style-type: none"> <li>• Check the piping for any gas leaks.</li> <li>• Check the piping and connection ports for dirt, oil or other foreign matter. If oily, contact the azbil Group and ask for repair.</li> <li>• Check the wiring to make sure that it is correct.</li> <li>• Check if the flow rate is extremely unstable or greatly exceeds the measurement range.</li> </ul>
The displayed value is lower than expected.	<ul style="list-style-type: none"> <li>• Check if the gas contains foreign matter such as dust, rust, oil or water.</li> </ul>
There should be no flow but the indicated flow rate is higher than zero.	If it seems that there is foreign matter in the flow meter, contact the azbil Group and ask for repair.
The indicated instantaneous flow rate is zero, but the integrated flow counting up or, counting down.	<ul style="list-style-type: none"> <li>• Check the piping for any gas leaks, and check if the gas flow has actually stopped.</li> <li>• Even if the instantaneous flow rate display is 0, a minute flow smaller than the minimum display value of the flowmeter might be present. For integrated measurements, even a flow under the minimum display value is counted. Set the low flow cutoff to prevent integrated flow countup or countdown.</li> </ul>  Function setup, page 19



# Chapter 6. SPECIFICATIONS

## ■ General specifications

Item		CMS9500	CMS0002	CMS0005
Compatible gases*1		Air, nitrogen, argon, oxygen, carbon dioxide (CO <sub>2</sub> ), natural gas 13A (LNG base)*2, 100% methane, 100% propane, and 100% butane. The gas must be a dry gas which does not contain any corrosive component (chlorine, sulfur, acid, etc.). It also must be a clean gas which does not contain dust or oil mist.		
Flow rate range for air*3		0 to 500 mL/min (standard)	0 to 2 L/min (standard)	0 to 5 L/min (standard)
		L/min (standard) refers to the flow rate after conversion to 20°C, 101.325kPa (1 atmosphere).		
Maximum measured flow rate for each gas (at 20°C, 101.325kPa)	Air/nitrogen	500 mL/min	2 L/min	5 L/min
	Argon	500 mL/min	2 L/min	5 L/min
	Carbon dioxide	250 mL/min	1 L/min	3.3 L/min
	Oxygen*4	500 mL/min	2 L/min	5 L/min
	Natural gas 13A -46MJ*2	400 mL/min	1.5 L/min	4.5 L/min
	Methane	500 mL/min	2 L/min	5 L/min
	Propane	140 mL/min	0.5 L/min	1.7 L/min
	Butane	100 mL/min	0.4 L/min	1.25 L/min
	Natural gas 13A -45MJ*2	400 mL/min	1.5 L/min	4.5 L/min
Measurement accuracy at 23°C, 101.325kPa ( $\chi$ is the measured flowrate)*5		5 ≤ $\chi$ < 100mL/min ±1% FS ± 1 digit 100 ≤ $\chi$ ≤ 500mL/min ±3% rdg ± 1 digit	0.02 ≤ $\chi$ < 0.4L/min ±1% FS ± 1 digit 0.4 ≤ $\chi$ ≤ 2L/min 3% rdg ± 1 digit	0.05 ≤ $\chi$ < 1L/min 1% FS ± 1 digit 1 ≤ $\chi$ ≤ 5L/min 3% rdg ± 1 digit
Temperature drift (in -10 to +60°C range)*6		From 0 to 75% of flow rate range: ±0.10% FS/°C ± 1 digit or less From 75 to 100% of flow rate range: ±0.15% FS/°C ± 1 digit or less		
Pressure drift *7	Applied pressure of 0 to 1.0 MPa	±0.1% FS / 0.1 MPa ± 1 digit or less		±0.25% FS / 0.1 MPa ± 1 digit or less
	Negative applied pressure of -0.07 to 0 MPa	±0.2% FS / 0.01 MPa ± 1 digit or less		
Operating temperature range		-10 to +60°C		
Storage temperature range		-20 to +70°C		
Operating humidity range		10 to 90% RH (without condensation)		
Operating pressure range		-0.07 to +1.0 MPa		
Pressure resistance		1.5MPa		
Connection aperture/ Connection standard		SUS model: Rc 1/4" SUS316 model: 9/16-18 UNF, Rc 1/4", 1/4" Swagelok, 1/4" VCR (select one suitable for the model No.)		
Body material		SUS model: SUS303 and SUS316 SUS316 model: SUS316		
Case material		Polycarbonate		
Mounting position		Horizontal mounting. (Top surface must not face down.) If this device is mounted vertically, drift may cause erroneous measurement when the actual flow rate is zero. For details, contact the azbil Group.		
Rated voltage		12 to 24Vdc		
Supply voltage range		11.4 to 25.2Vdc		
Current consumption		100mA max.		
Sampling cycle		100ms ± 10ms		

CMS0020	CMS0050	CMS0200	CMS0500
Air, nitrogen, argon, oxygen, carbon dioxide (CO <sub>2</sub> ), natural gas 13A (LNG base)*2, 100% methane, 100% propane, and 100% butane. The gas must be a dry gas which does not contain any corrosive component (chlorine, sulfur, acid, etc.). It also must be a clean gas which does not contain dust or oil mist.			
0 to 20 L/min (standard)	0 to 50 L/min (standard)	0 to 200 L/min (standard)	0 to 500 L/min (standard)
L/min (standard) refers to the flow rate after conversion to 20°C, 101.325kPa (1 atmosphere).			
20 L/min	50 L/min	200 L/min	500 L/min
20 L/min	50 L/min	200 L/min	500 L/min
10 L/min	25 L/min	100 L/min	250 L/min
20 L/min	50 L/min	200 L/min	500 L/min
15 L/min	40 L/min	150 L/min	400 L/min
20 L/min	50 L/min	200 L/min	500 L/min
5 L/min	14 L/min	50 L/min	140 L/min
5 L/min	12 L/min	50 L/min	120 L/min
15 L/min	40 L/min	150 L/min	400 L/min
0.2 ≤ $\chi$ < 2L/min ±1% FS ± 1 digit 2 ≤ $\chi$ ≤ 20L/min ±3% rdg ± 1 digit	0.5 ≤ $\chi$ < 5L/min ±1% FS ± 1 digit 5 ≤ $\chi$ ≤ 50L/min ±3% rdg ± 1 digit	2 ≤ $\chi$ < 20L/min 1% FS ± 1 digit 20 ≤ $\chi$ ≤ 200L/min ±3% rdg ± 1 digit	5 ≤ $\chi$ < 50L/min 1% FS ± 1 digit 50 ≤ $\chi$ ≤ 500L/min ±3% rdg ± 1 digit
From 0 to 75% of flow rate range: ±0.10% FS/°C ± 1 digit or less From 75 to 100% of flow rate range: ±0.15% FS/°C ± 1 digit or less			
±0.2% FS / 0.1 MPa ±1 digit or less	±0.1% FS / 0.1 MPa ±1 digit or less	±0.2% FS / 0.1 MPa ±1 digit or less	
±0.2% FS / 0.01MPa ± 1digit or less			
-10 to +60°C			
-20 to +70°C			
10 to 90% RH (without condensation)			
-0.07 to +1.0 MPa			
1.5MPa			
SUS model: Rc 1/4" SUS316 model: 9/16-18 UNF, Rc 1/4", 1/4" Swagelok, 1/4" VCR (select one suitable for the model No.)		SUS303: Rc 1/2" SUS316 model: 3/4-16 UNF, Rc 1/4", 1/2" Swagelok, 3/8" VCR (select one suitable for the model No.)	
SUS model: SUS303 and SUS316 SUS316 model: SUS316			
Polycarbonate			
Horizontal mounting. (Top surface must not face down.) If this device is mounted vertically, drift may cause erroneous measurement when the actual flow rate is zero. For details, contact the azbil Group.			
12 to 24Vdc			
11.4 to 25.2Vdc			
100mA max.			
100ms ± 10ms			

Item		CMS9500	CMS0002	CMS0005	
Display	Flow rate display	4-digit 7-segment LED, selectable between instantaneous flow rate and integrated flow display.			
	Instantaneous flow rate	Min. display	1 mL/min	0.01 L/min (0.005 L/min)* <sup>8</sup>	0.01 L/min
		Resolution	1 mL/min	0.01 L/min (0.005 L/min)* <sup>8</sup>	0.01 L/min
	Integrated flow rate	Display unit	10 mL	1 L	
		Display range	0 to 99999999		
		Data storage	Data is written to memory every 10 minutes. (Integrated flow count or countdown can be reset by control panel key or external contact input.)		
Indicator LEDs		Instantaneous flow rate display, integrated flow display, event 1 & 2 display			
Output signal (instantaneous flowrate output)	If 0-5 or 1-5Vdc is selected: <ul style="list-style-type: none"> <li>• Allowable load resistance 250kΩ min.</li> <li>• Even if the measurement range is exceeded, output remains less than 6V.</li> </ul> If 4-20mAadc is selected: <ul style="list-style-type: none"> <li>• Allowable load resistance 300Ω max.</li> <li>• Even if the measurement range is exceeded, output remains less than 24mA.</li> </ul>				
Output scaling function* <sup>9</sup>	Selectable from 0 to 100, 0 to 200, 0 to 300, 0 to 500mL/min. Factory setting: 0 to 500mL/min.	Selectable from 0 to 0.2, 0 to 0.5, 0 to 1, 0 to 2 L/min. Factory setting: 0 to 2 L/min.	Selectable from 0 to 1, 0 to 2, 0 to 3, 0 to 5 L/min. Factory setting: 0 to 5 L/min.		
Event output	Number of outputs	2			
	Type	Open collector (absolute maximum ratings 30Vdc, 50mA)			
	Totalizer pulse output width	100ms ± 10%			
	Totalizer pulse output weight	10, 100, 1000mL/pulse	1, 10, 100L/pulse		
External input	Number of inputs	1 (dedicated to reset of integrated count)			
	Remote circuit type	Circuit type on other side: No-voltage contact or open collector Contact OFF terminal voltage: 4.5 ± 1V Contact ON terminal current: Approx. 0.5mA (current flowing to contact) Allowable ON contact resistance: 250kΩ max. Allowable OFF contact resistance: 100kΩ min. Allowable ON residual voltage: 0.8V max. (open collector on other side) Allowable OFF leakage current: 50µA max. (open collector on other side)			
Gas type switching function	Selection of air/nitrogen, argon, carbon dioxide (CO <sub>2</sub> ), oxygen (only gas type S models), natural gas 13A-46MJ, 100% methane, 100% propane, 100% butane, and natural gas 13A-45MJ using the control panel keys.				
Gas type setup function	Gas type conversion factor between 0.100 and 8.000 can be set using the control panel keys.				
Electrical connection	<ul style="list-style-type: none"> <li>• Harness with a special connector (optional)</li> <li>• Mating connector: Hirose Electric Co. DF-11-10DS-2C</li> </ul>				
Standards compliance	EN61326-1:1997 A1:1998 A2:2001 A3:2003				
Mass	Approx. 800g				

\*1: The flowmeter can also be used for some gases not listed in this table by means of the gas type conversion factor function. For details, contact the azbil Group.

\*2: Calibration for natural gas 13A is based on the two standard types described below (gas type can be switched by control panel keys). If the composition of your 13A is different, contact the azbil Group.

Gas type (as used by Azbil Corporation)	Calorific value MJ/m <sup>3</sup> (N)	Methane (%)	Ethane (%)	Propane (%)	Butane (%)
Natural gas 13A-46MJ	46.04655	88	5.8	4.5	1.7
Natural gas 13A-45MJ	45.007	88.9	6.8	3.1	1.2

\*3: Flow rate ranges are for air. This product has a gas type selection function which allows selection of the desired gas type using control panel keys. See "Maximum measurable flow rates for each gas type" on page 32. Also, the output scaling function allows the user to scale the 0-5V output using the keys.

CMS0020	CMS0050	CMS0200	CMS0500
4-digit 7-segment LED, selectable between instantaneous flow rate and integrated flow display.			
0.1 L/min (0.05 L/min) <sup>*8</sup>	0.1 L/min	1 L/min (0.5 L/min) <sup>*8</sup>	1 L/min
0.1 L/min (0.05 L/min) <sup>*8</sup>	0.1 L/min	1 L/min (0.5 L/min) <sup>*8</sup>	1 L/min
1 L		10 L	
0 to 99999999			
Data is written to memory every 10 minutes. (Integrated flow count or countdown can be reset by control panel key or external contact input.)			
Instantaneous flow rate display, integrated flow display, event 1 & 2 display			
If 0-5 or 1-5Vdc is selected: <ul style="list-style-type: none"> <li>• Allowable load resistance 250kΩ min.</li> <li>• Even if the measurement range is exceeded, output remains less than 6V.</li> </ul>			
If 4-20mAdc is selected: <ul style="list-style-type: none"> <li>• Allowable load resistance 300Ω max.</li> <li>• Even if the measurement range is exceeded, output remains less than 24mA.</li> </ul>			
Selectable from 0 to 2, 0 to 5, 0 to 10, 0 to 20 L/min. Factory setting: 0 to 20 L/min.	Selectable from 0 to 10, 0 to 20, 0 to 30, 0 to 50 L/min. Factory setting: 0 to 50 L/min.	Selectable from 0 to 20, 0 to 50, 0 to 100, 0 to 200 L/min. Factory setting: 0 to 200 L/min.	Selectable from 0 to 100, 0 to 200, 0 to 300, 0 to 500 L/min. Factory setting: 0 to 500 L/min.
2			
Open collector (absolute maximum ratings: 30Vdc, 50mA)			
100ms ± 10%			
1, 10, 100L/pulse		10, 100, 1000L/pulse	
1 (dedicated to reset of integrated count)			
Circuit type on other side: No-voltage contact or open collector			
Contact OFF terminal voltage: 4.5 ± 1V			
Contact ON terminal current: approx. 0.5mA (current flowing to contact)			
Allowable ON contact resistance: 250Ω max.			
Allowable OFF contact resistance: 100kΩ min.			
Allowable ON residual voltage: 0.8V max. (open collector on other side)			
Allowable OFF leakage current: 50µA max. (open collector on other side)			
Selection of air/nitrogen, argon, carbon dioxide (CO <sub>2</sub> ), oxygen (only gas type S models), natural gas 13A-46MJ, 100% methane, 100% propane, 100% butane, and natural gas 13A-45MJ using the control panel keys.			
Gas type conversion factor between 0.100 and 8.000 can be set using the control panel keys.			
Harness with a special connector (optional)			
Mating connector: Hirose Electric Co. DF-11-10DS-2C			
EN61326-1:1997 A1:1998 A2:2001 A3:2003			
Approx. 800g		Approx. 1400g	Approx. 2000g

\*4: Only models with the catalog listing CMS\_\_\_\_\_B\_\_S\_\_\_1\_\_ are for oxygen use.

\*5: Accuracy for air/nitrogen and oxygen (for oxygen model). The standard temperature (target temperature for calibration) is 23°C.

\*6: At 101.325kPa, the amount of variation as compared with flow rate at 23°C.

\*7: At 23°C, the amount of variation as compared with flow rate at 101.325kPa.

\*8: When the gas type conversion factor is set between 0.100 and 0.499.

\*9: The 0 to 5V output can be scaled using the control panel keys. If gas type selection (function setup 08) is changed, the measurable flow rate range changes as specified on page 32 ("Maximum measurable flow rate for each gas type"). However, scaling according to the analog output scaling setting will be applied to the output regardless of what gas type is selected.

● **Maximum measurable flow rate for each gas type**

The output voltage columns show the output when the 0-5V analog output scaling is set for the maximum measurable flow rate.

Gas type	CMS9500			CMS0002		
	Maximum measurable flow rate (mL/min)	Output voltage (V)	Set up/display resolution (mL/min)	Maximum measurable flow rate (L/min)	Output voltage (V)	Set up/display resolution (L/min)
Air/nitrogen	500	5	1	2	5	0.01
Argon	500	5	1	2	5	0.01
Carbon dioxide	250	2.5	1	1	2.5	0.01
Oxygen*2	500	5	1	2	5	0.01
Natural gas 13A	400	4	1	1.5	3.75	0.01
Methane	500	5	1	2	5	0.01
Propane	140	1.4	1	0.5	1.25	0.005
Butane	100	1	1	0.4	1	0.005
User specified	[*1]	5	1	[*1]	5	0.01 [*3]

Gas type	CMS0005			CMS0020		
	Maximum measurable flow rate (L/min)	Output voltage (V)	Set up/display resolution (L/min)	Maximum measurable flow rate (L/min)	Output voltage (V)	Set up/display resolution (L/min)
Air/nitrogen	5	5	0.01	20	5	0.1
Argon	5	5	0.01	20	5	0.1
Carbon dioxide	3.3	3.3	0.01	10	2.5	0.1
Oxygen*2	5	5	0.01	20	5	0.1
Natural gas 13A	4.5	4	0.01	15	3.75	0.1
Methane	5	5	0.01	20	5	0.1
Propane	1.7	1.7	0.01	5	1.25	0.05
Butane	1.25	1.25	0.01	5	1.25	0.05
User specified	[*1]	5	0.01	[*1]	5	0.1 [*3]

Gas type	CMS0050			CMS0200		
	Maximum measurable flow rate (L/min)	Output voltage (V)	Set up/display resolution (L/min)	Maximum measurable flow rate (L/min)	Output voltage (V)	Set up/display resolution (L/min)
Air/nitrogen	50	5	0.1	200	5	1
Argon	50	5	0.1	200	5	1
Carbon dioxide	25	2.5	0.1	100	2.5	1
Oxygen*2	50	5	0.1	200	5	1
Natural gas 13A	40	4	0.1	150	3.75	1
Methane	50	5	0.1	200	5	1
Propane	14	1.4	0.1	50	1.25	0.5
Butane	12	1.2	0.1	50	1.25	0.5
User specified	[*1]	5	0.1	[*1]	5	1 [*3]



Gas type	CMS0050		
	Maximum measurable flow rate (L/min)	Output voltage (V)	Set up/display resolution (L/min)
Air/nitrogen	500	5	1
Argon	500	5	1
Carbon dioxide	250	2.5	1
Oxygen*2	500	5	1
Natural gas 13A	400	4	1
Methane	500	5	1
Propane	140	1.4	1
Butane	120	1.2	1
User specified	[*1]	5	1

\*1: The gas type conversion factor can be set from 0.100 to 8,000. The maximum measurable flow rate for each model is as follows:

CMS9500:  $500(\text{mL}/\text{min}) \times \text{gas type conversion factor}$

CMS0002:  $2(\text{L}/\text{min}) \times \text{gas type conversion factor}$

CMS0005:  $5(\text{L}/\text{min}) \times \text{gas type conversion factor}$

CMS0020:  $20(\text{L}/\text{min}) \times \text{gas type conversion factor}$

CMS0050:  $50(\text{L}/\text{min}) \times \text{gas type conversion factor}$

CMS0200:  $200(\text{L}/\text{min}) \times \text{gas type conversion factor}$

CMS0500:  $500(\text{L}/\text{min}) \times \text{gas type conversion factor}$

\*2: Applies only to oxygen models.

\*3: When the gas type conversion factor is 0.100 to 0.499, the display and set resolution become those shown below.

CMS0002:  $0.005(\text{L}/\text{min})$

CMS0020:  $0.05(\text{L}/\text{min})$

CMS0200:  $0.5(\text{L}/\text{min})$

■ External dimensions

● SUS model CMS9500/0002/0005/0020/0050

Unit: mm

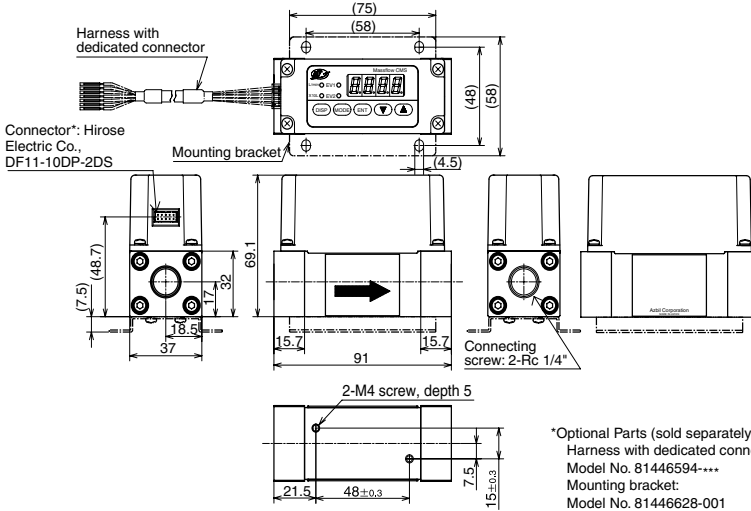

● SUS model CMS0200

Unit: mm

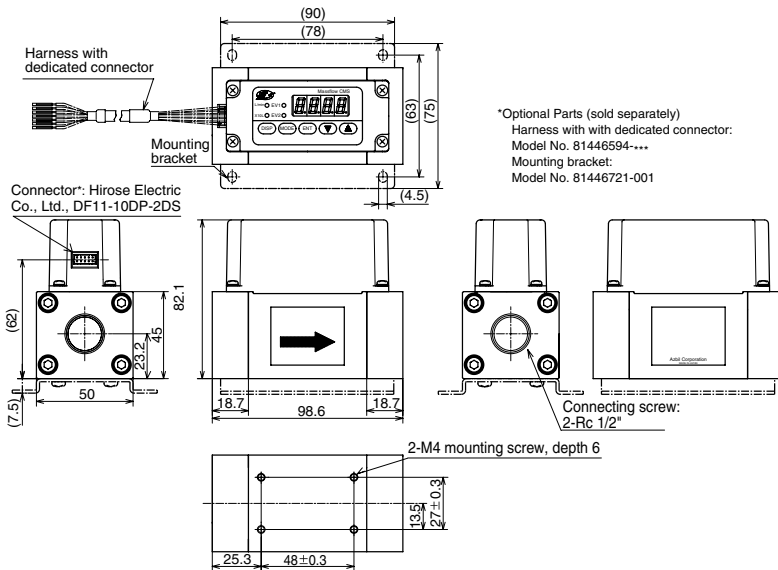

● SUS model CMS0500

Unit: mm

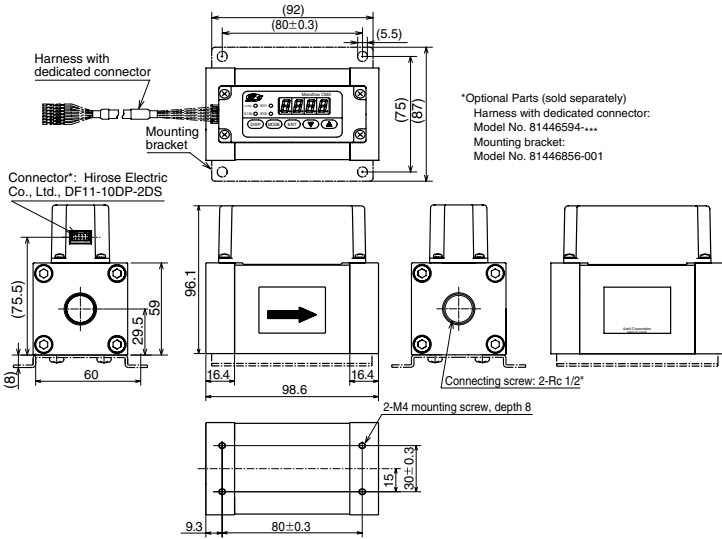

● SUS316 model CMS9500/0002/0005/0020/0050

Unit: mm

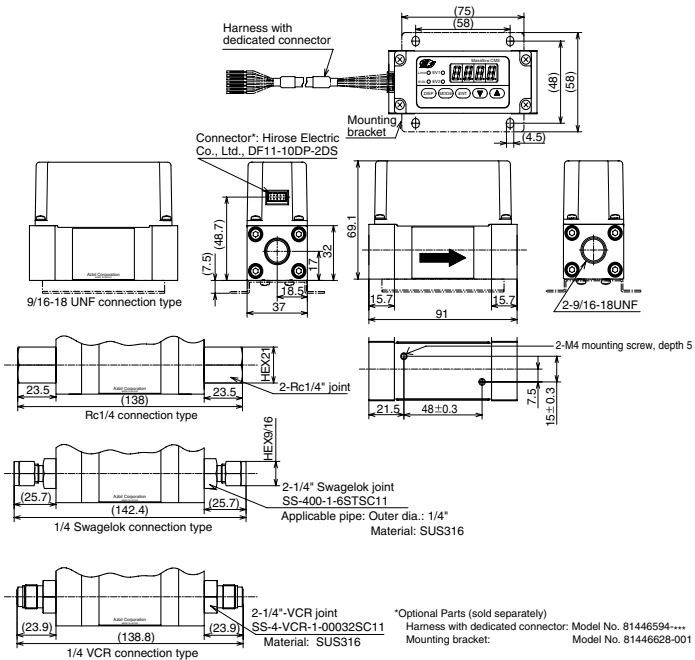

● SUS316 model CMS0200

Unit: mm

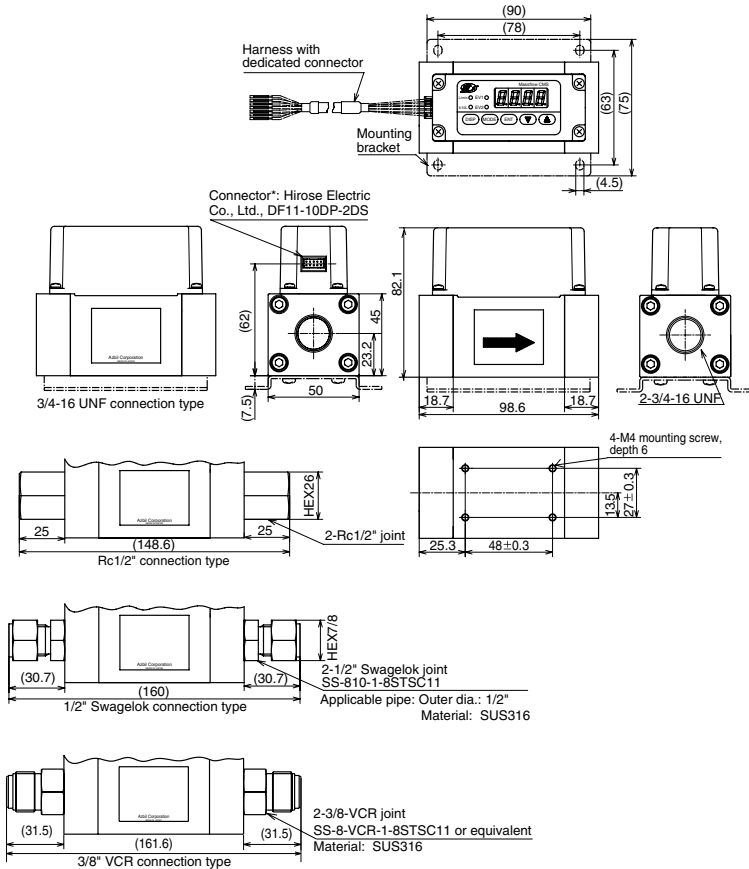

\*Optional Parts (sold separately)  
 Harness with dedicated connector: Model No. 81446594-\*\*\*  
 Mounting bracket: Model No. 81446721-001

● SUS316 model CMS0500

Unit: mm

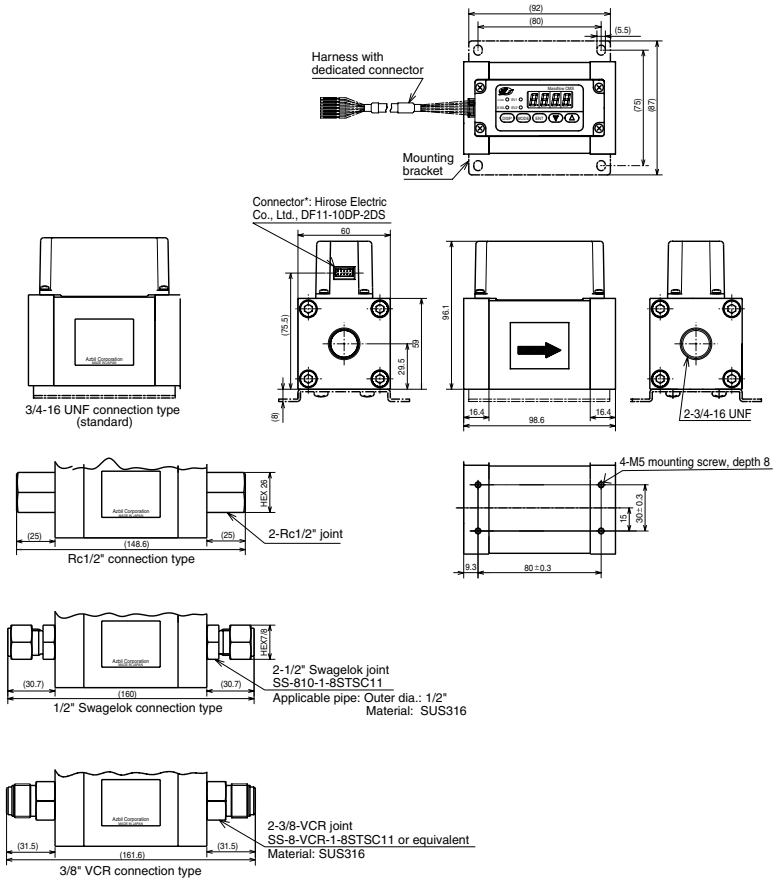

\*Optional Parts (sold separately)  
 Harness with dedicated connector:  
 Model No. 81446594-\*\*\*  
 Mounting bracket:  
 Model No. 81446856-001

● **Harness with dedicated connector 81446594-\*\*\***

81446594-005, -006



81446594-007, -008

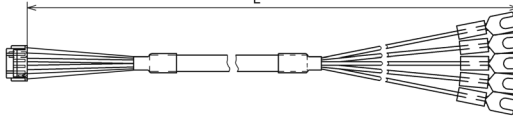

Last 3 digits of model No.	L (mm)	No. of wire
005	2000 <sup>+50</sup> <sub>0</sub>	8
006	5000 <sup>+250</sup> <sub>0</sub>	8
007	2000 <sup>+80</sup> <sub>0</sub>	10
008	5000 <sup>+250</sup> <sub>0</sub>	10

● **AC adapter**

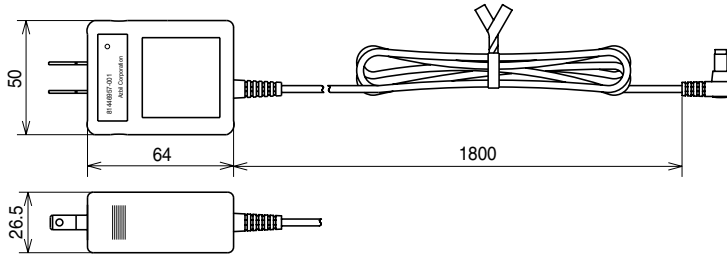

Note: The 81446594-030 AC adapter connection harness is necessary when supplying AC power to the CMS.

● **81446594-030 AC adapter connection harness**

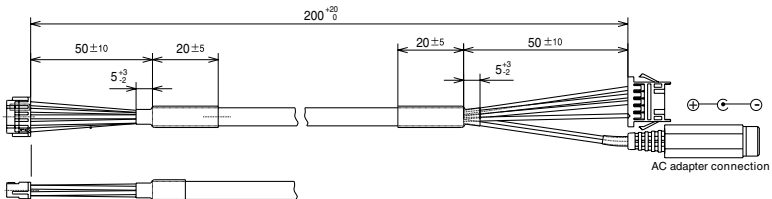

● **Mounting bracket, 81446628-001 (for CMS9500/0002/0005/0020/0050)**

Material: SUS304

Unit: mm

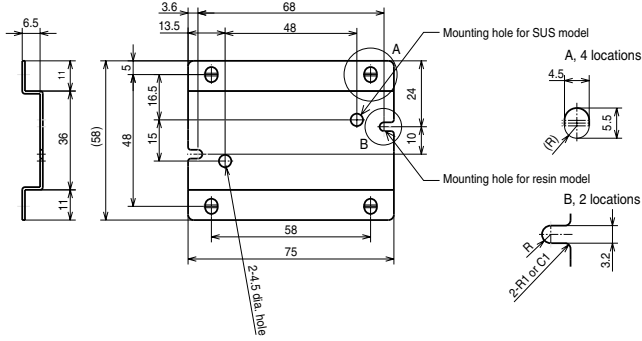

● **Mounting bracket, 81446721-001 (for CMS0200)**

Material: SUS304

Unit: mm

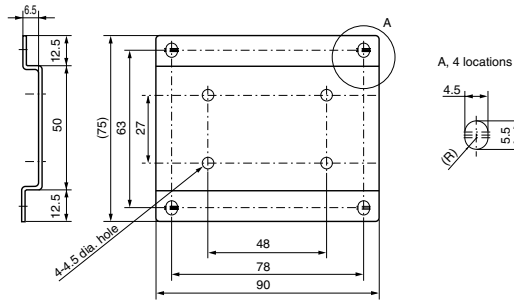

● **Mounting bracket, 81446856-001 (for CMS0500)**

Material: SUS304

Unit: mm

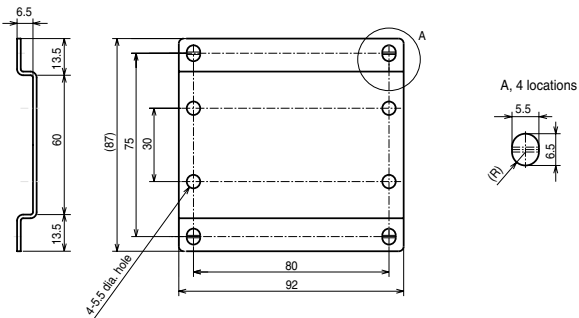

■ Pressure loss

The graphs below are based on data for air. The values for gases other than air can be obtained by multiplying by the specific gravities shown in the table below.

Specific gravity (with air as 1.0)	
Argon	1.38
Carbon dioxide	1.53
Oxygen	1.11
Natural gas 13A	0.64
100% Methane	0.56
100% Propane	1.56
100% Butane	2.08

Example: For the CMS9500, with a primary pressure of 100 kPa and a flow rate of 500mL/min, the pressure loss for argon is calculated as follows:

From the graph for CMS9500, you know that the pressure loss is about 4.3Pa when the primary pressure is 100 kPa and the flow rate is 500mL/min.

Multiply this value by 1.38, the specific gravity of argon, and the result is  $4.3 \times 1.38 = 5.934$  Pa.

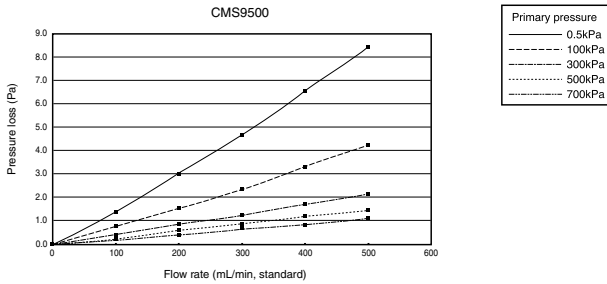



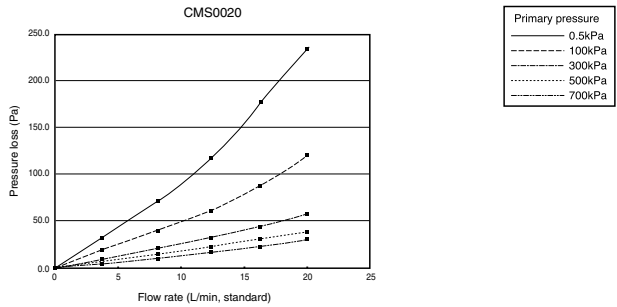
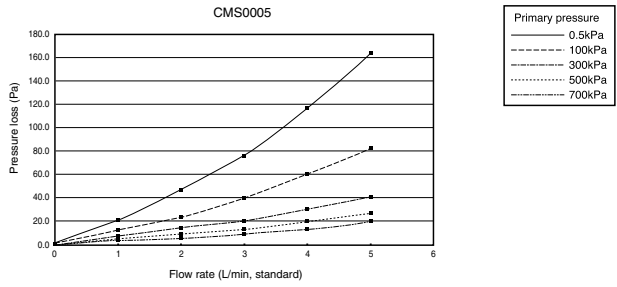
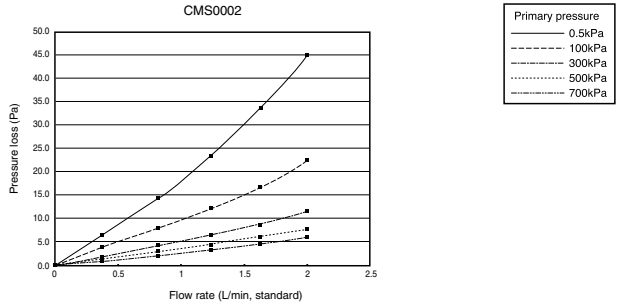

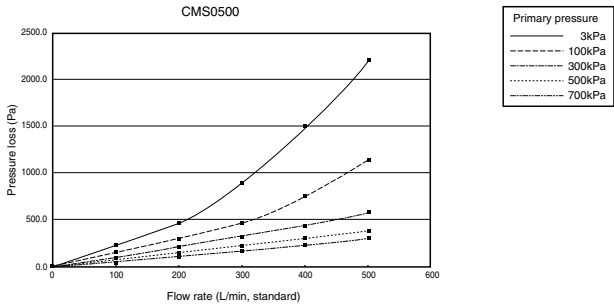
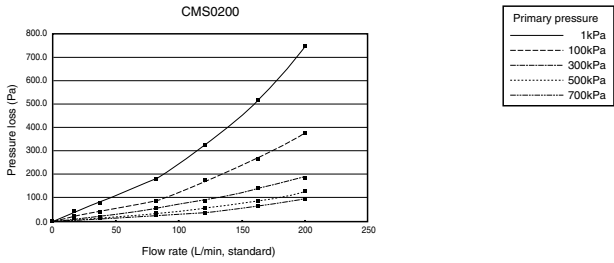
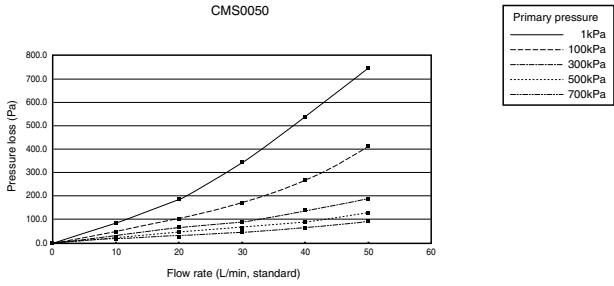



**azbil**

*Specifications are subject to change without notice.* (09)

---

**Azbil Corporation**

Advanced Automation Company

1-12-2 Kawana, Fujisawa  
Kanagawa 251-8522 Japan

URL: <http://www.azbil.com>

1st edition: Dec. 2006 (U)  
2nd edition: Apr. 2012 (F)