



USER INSTRUCTIONS

RG Series Standard Actuator

Jackscrew Override
Sandwich Gearbox Override
Hydraulic Override

Installation
Operation
Maintenance

FCD AXENIM0123-00 12/09

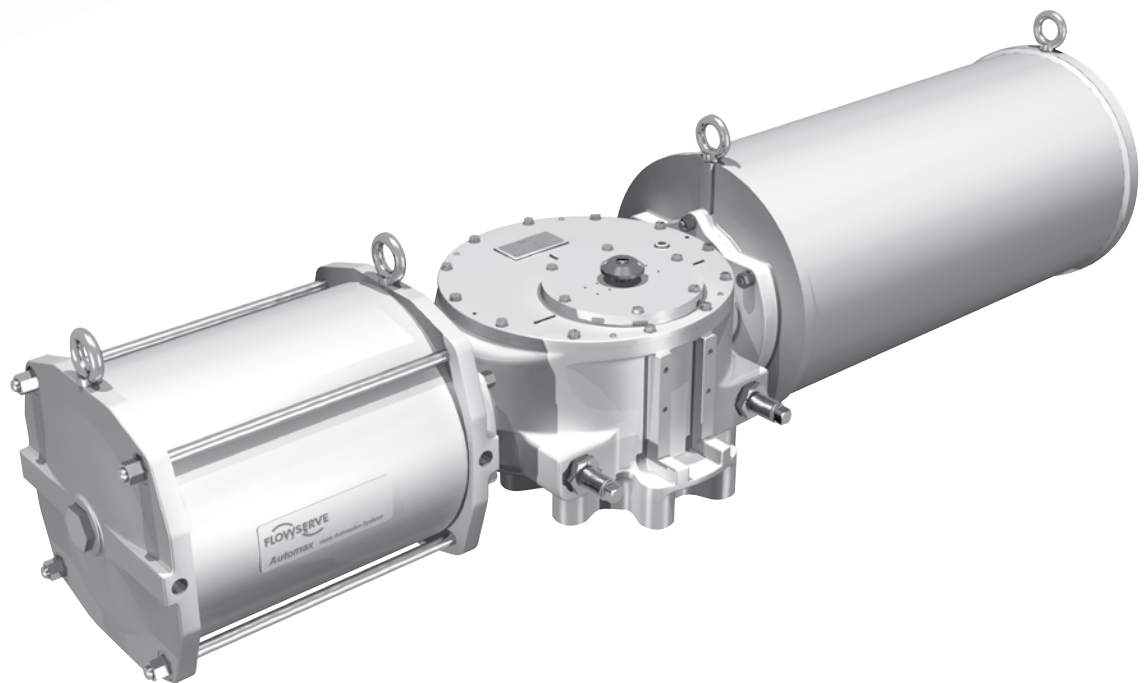

INDEX

1 Using Flowserve valves, actuators and accessories correctly

2 Jackscrew Override

2.2 Install jackscrew override onto heavy duty DA actuator

2.3 install jackscrew override onto existing heavy duty SR actuator

2.4 Operation –Jackscrew Override

2.5 Automatic Operation

3 Gear Override

3.2 Retrofit Gear Override onto Existing RG Actuator Installation

3.3 Mount a Preassembled Actuator

3.4 Operation

3.5 Restoring Automatic Operation

4 Hydraulic Override

4.2 Install hydraulic override onto existing heavy duty Spring Return actuator

4.3 Operation –SR Override

4.4 Install hydraulic override on Standard DA heavy duty actuator

4.5 Operation –DA Override

1 Using Flowserve Valves, Actuators and Accessories Correctly

1.1 General usage

The following instructions are designed to assist in unpacking, installing and performing maintenance as required on FLOWSERVE products. Product users and maintenance personnel should thoroughly review this bulletin prior to installing, operating or performing any maintenance.

In most cases FLOWSERVE valves, actuators and accessories are designed for specific applications with regard to medium, pressure and temperature. For this reason they should not be used in other applications without first contacting the manufacturer.

1.2 Terms concerning safety

The safety terms **DANGER**, **WARNING**, **CAUTION** and **NOTE** are used in these instructions to highlight particular dangers and/or to provide additional information on aspects that may not be readily apparent.



DANGER: indicates that death, severe personal injury and/or substantial property damage will occur if proper precautions are not taken.



WARNING: indicates that death, severe personal injury and/or substantial property damage can occur if proper precautions are not taken.



CAUTION: indicates that minor personal injury and/or property damage can occur if proper precautions are not taken.



NOTE: indicates and provides additional technical information, which may not be very obvious even to qualified personnel.

Compliance with other, not particularly emphasised notes, with regard to transport, assembly, operation and maintenance and with regard to technical documentation (e.g. in the operating instruction, product documentation or on the product itself) is essential, in order to avoid faults, which in themselves might directly or indirectly cause severe personal injury or property damage.

1.3 Protective clothing

FLOWSERVE products are often used in problematic applications (e.g. extremely high pressures, dangerous, toxic or corrosive mediums). In particular valves with bellows seals point to such applications. When performing service, inspection or repair operations always ensure, that the valve and actuator are depressurised and that the valve has been cleaned and is free from harmful substances. In such cases pay particular attention to personal protection (protective clothing, gloves, glasses etc.).

1.4 Qualified personnel

Qualified personnel are people who, on account of their training, experience and instruction and their knowledge of relevant standards, specifications, accident prevention regulations and operating conditions, have been authorised by those responsible for the safety of the plant to perform the necessary work and who can recognise and avoid possible dangers.

1.5 Installation



DANGER: Before installation check the order-no., serial-no. and/or the tag-no. to ensure that the valve/ actuator is correct for the intended application.

Do not insulate extensions that are provided for hot or cold services.

Pipelines must be correctly aligned to ensure that the valve is not fitted under tension.

Fire protection must be provided by the user.

1.6 Spare parts

Use only FLOWSERVE original spare parts. FLOWSERVE cannot accept responsibility for any damages that occur from using spare parts or fastening materials from other manufactures. If FLOWSERVE products (especially sealing materials) have been on store for longer periods check these for corrosion or deterioration before using these products. Fire protection for FLOWSERVE products must be provided by the end user.

1.7 Service / repair

To avoid possible injury to personnel or damage to products, safety terms must be strictly adhered to. Modifying this product, substituting nonfactory parts, or using maintenance procedures other than outlined in this instruction could drastically affect performance and be hazardous to personnel and equipment, and may void existing warranties. Between actuator and valve there are moving parts. To avoid injury FLOWSERVE provides pinch-point-protection in the form of cover plates, especially where side-mounted positioners are fitted. If these plates are removed for inspection, service or repair special attention is required. After completing work the cover plates must be refitted.

Apart from the operating instructions and the obligatory accident prevention directives valid in the country of use, all recognised regulations for safety and good engineering practices must be followed.



WARNING: Before products are returned to FLOWSERVE for repair or service FLOWSERVE must be provided with a certificate which confirms that the product has been decontaminated and is clean. FLOWSERVE will not accept deliveries if a certificate has not been provided (a form can be obtained from FLOWSERVE).

1.8 Storage

In most cases FLOWSERVE products are manufactured from stainless steel. Products not manufactured from stainless steel are provided with an epoxy resin coating. This means that FLOWSERVE products are well protected from corrosion. Nevertheless FLOWSERVE products must be stored adequately in a clean, dry environment. Plastic caps are fitted to protect the flange faces to prevent the ingress of foreign materials. These caps should not be removed until the valve is actually mounted into the system.

1.9 Valve and actuator variations

These instructions cannot claim to cover all details of all possible product variations, nor can they provide information for every possible example of installation, operation or maintenance. This means that the instructions normally include only the directions to be followed by qualified personal where the product is being used for its defined purpose. If there are any uncertainties in this respect particularly in the event of missing product-related information, clarification must be obtained via the appropriate FLOWSERVE sales office.

1.10 Unpacking

Each delivery includes a packing slip. When unpacking, check all delivered valves and accessories using this packing slip.

Report transport damage to the carrier immediately.

In case of discrepancies, contact your nearest FLOWSERVE location.

2 Heavy Duty Jackscrew Overrides

Jackscrew overrides on Automax heavy duty actuators provide economical, durable method for manually operating the actuator. The jackscrews are either direct operating or bevel gearbox driven, to reduce operation effort. The direct operation consists of a rotating screw, threading into the nut which is fitted on the Torque module/ Spring module, and the hand wheel directly turns the screw.

The bevel gearbox driven jackscrew, has an arrangement of rotating nut and a rising screw. The higher thrust requirements for models bigger than 4000 Nm and for the stiffer springs are met with this type of jackscrew design.

Jackscrews are available on models RG1 through RG5.

2.1 Installation

Automax standard jackscrew overrides are provided as a complete integral component of the heavy duty actuator. Override units are shipped with the jackscrew assembly mounted to the actuator and vent valves installed on the pressure module. No additional customer installation is required. Refer Automax Heavy Duty IOM (FCD AXENIM0121) for instructions on installing Heavy Duty actuator into service.

2.2 Install jackscrew override onto heavy duty DA actuator (see Fig.: 1)

- 2.2.1 Disconnect air pressure and electrical power from actuator.
- 2.2.2 Remove the DA end cover plate.
- 2.2.3 Back off the jackscrew fully in the assembly and mount the jackscrew assembly on the torque module end flange, locating the spigot in the Torque module.

- 2.2.4 Use the jackscrew mounting kit and the O-ring from the DA cover.
- 2.2.5 Tighten the mounting stud nuts fully, with lock washers from the kit.
- 2.2.6 Fix the 3 way vent valves supplied in the kit, to both ports of the pressure module and connect air supply pressure lines to these valves.
- 2.2.7 Installation of pressure module side jackscrew requires replacement of std end plate of the pressure module. Remove tie rod nuts and end plate, and fit in the jackscrew assembly, supplied preassembled with the suitable thrust base End Plate. Tighten the tie rod nuts back on the pressure module. Fix the 3way valve on the ports.

2.3 Install jackscrew override onto existing heavy duty SR actuator (see Fig.: 2)

- 2.3.1 Disconnect air pressure and electrical power from actuator.
- 2.3.2 Remove the end cover plate on the Spring module, retaining the cover O-ring.
- 2.3.3 Tighten the mounting studs from the mounting kit with thread lock compound into the spring module end plate.
- 2.3.4 Back off the jackscrew fully in the assembly and mount the jackscrew assembly on the spring module end plate's thrust base, locating the spigot in the spring module end plate.

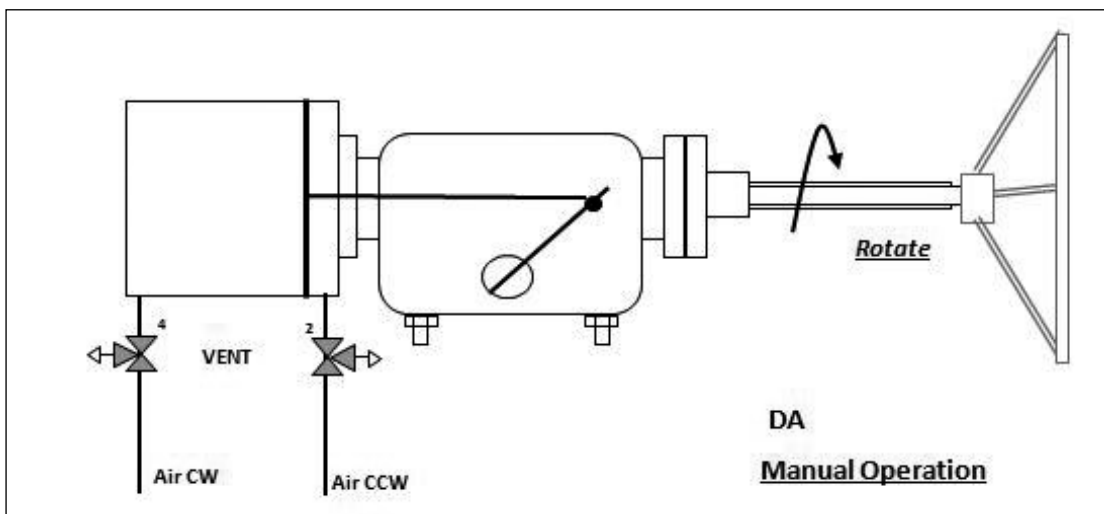

Fig.: 1 Install Jackscrew Override (DA)

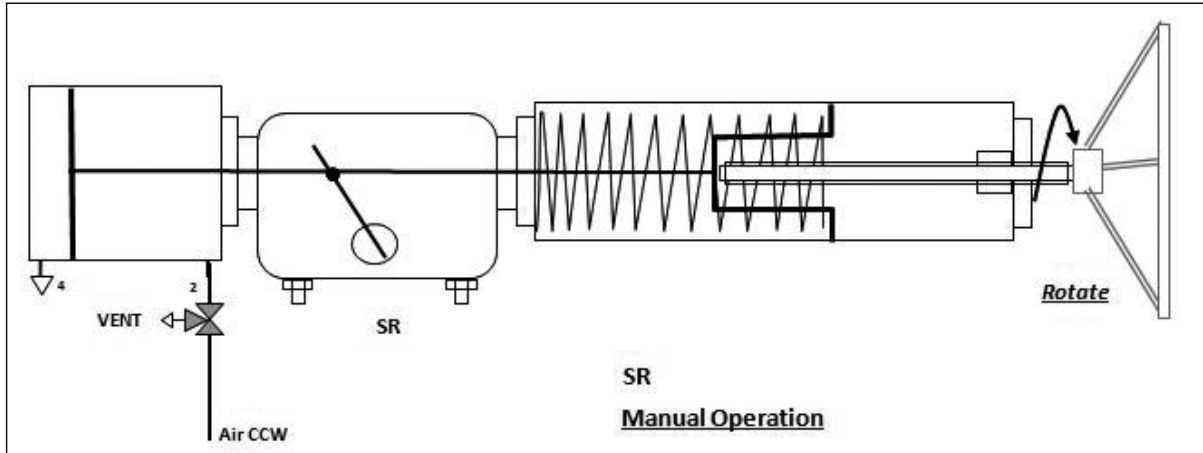

Fig.: 2 Install Jackscrew Override (SR)

- 2.3.5 Locate the jackscrew nut or the spool (for bevel gear-box jackscrews) into the studs and tighten the nuts fully, with lock washers from the kit.
- 2.3.6 Fix a 3 way valve, to the pressure module's rod end side port and connect air supply pressure line to it, see fig.

2.4 Operation –Jackscrew Override

- 2.4.1 To test / operate the override, turn the 3 way valves to shut off air supply and vent the cylinder ports.
- 2.4.2 Turning the hand wheel clockwise advances the screw into the torque / spring module for DA/SR models.
- 2.4.3 Resistance will be felt when the thrust head of the jackscrew touches the guide block face in case of DA actuator or on the Pull Rod hex end, in case of the SR model.
- 2.4.4 Tightening the hand wheel further clockwise will cause the guide block to move against the resistance from the valve/ spring and effect the override function.

2.5 Automatic Operation

- 2.5.1 Operate hand wheel counterclockwise to completely retract the jackscrews and lock the position with the locknut on the jackscrew.
- 2.5.2 Turn the 3way valves on the pressure module to connect to air supply.
- 2.5.3 Operate actuator normally on supply pressure.

! *NOTE: In case of SR jackscrew, the spring constantly loads the screw, and returns the actuator to fail safe state when the jackscrew is retracted. But in case of DA models, the jackscrew on torque module retracts free of load and does not move the actuator in the other direction. An additional jackscrew on the pressure module would be required for this.*

3 Heavy Duty Gear Overrides

Gear overrides on Automax RG series heavy duty actuators are available for models RG1 through RG5 providing a convenient and safe method for manually operating the actuator, in event of supply failure. These are declutchable for efficient, automatic operation. The gear override consists of a declutchable gearbox mounted below the actuator, and is positioned between the RG series actuator and the valve/damper to be actuated.

Any accessories, such as limit switches and positioners, are not disturbed and continue to be mounted on the NAMUR mounting drive, on top side of the actuator.

The gear override is designed for the full rated torque of the actuator and has an identical ISO base and bolting patterned, as the actuator.

! ***NOTE: In the event that needs the actuator to be removed from the valve for maintenance or repair, the gearbox can be left mounted on the valve, to allow manual operation.***

3.1 Installation

Automax standard sandwich gear overrides are provided as a modular component of the heavy duty actuator. Gear override units are shipped with the gear mounted to the actuator. The vent valves are installed on the pressure cylinder. No additional customer installation is required. Refer Automax Heavy Duty RG series IOM (FCD AXENIM0121) for instructions on installing Heavy Duty actuator into service.

3.2 Retrofit gear override onto existing RG actuator installation

- 3.2.1 Disconnect air pressure and electrical power from actuator and dismount the actuator from valve/mounting bracket.
- 3.2.2 Thread in fully, the studs from the Gear Override Mounting Kit, into the mounting base of the removed actuator.
- 3.2.3 Orient the manual override gear to the fail safe position of the actuator, if actuator is spring return model, or else bring both the actuator and the gear to the same position, say Clockwise end. Back off the gearbox's travel stops.
- 3.2.4 The coupler shaft is fitted into and supplied with the gearbox. The coupler shaft bottoms out on the step/circlip inside the gear bore, preventing it from sliding through the gear bore.
- 3.2.5 Mount the actuator on to the coupler shaft, into the yoke bore of the actuator, aligning the keys on the shaft to the

keyways in the Yoke bore. Declutch the manual gearbox (see instructions on gear box to disengage lock pin and disengage the worm shaft).

- 3.2.6 Seat the actuator fully on the override gearbox flange and thread in the Nuts with Lock washers from the Mounting Kit, from below the mounting flange. Torque the Nuts to rated torque for the Nut size.
- 3.2.7 Now this assembly is mounted on the valve stem or on the bracket and coupler shaft, the way the actuator was seated.
- 3.2.8 Bolt up the Gear drive mounting with the fasteners removed from the actuator-valve mounting.
- 3.2.9 Fit the 3 way valves to pressure module, per schematic (see Figs. on page 5).

! ***NOTE: After mounting actuator to valve, the gear override travel stops must be set. First make sure that the actuator travel stops are set correctly. Then set the gear override travel stops to the same position.***

3.3 Mount a preassembled actuator- gear override assembly on the valve, a mounting bracket and a Coupler/ Adaptor shaft is required with the mounting kit.

- 3.3.1 Fix the mounting bracket on to the valve with the fasteners from the mounting kit.
- 3.3.2 Locate the Coupler/Adaptor shaft supplied, on the valve stem and lock to the stem.
- 3.3.3 Orient the actuator and the valve to same position, usually the fail safe condition of the actuator for SR/SO models and full clockwise end, for DA models.
- 3.3.4 Disengage the worm shaft from the worm wheel of the override gearbox (see declutching instructions on the override gearbox). Back off the override gearbox's travel stops.
- 3.3.5 Now mount the actuator-override gearbox assembly on the coupler shaft, aligning the keys into the keyways in the gear bore. Seat the actuator assembly on the bracket and fasten with the mounting bolts.
- 3.3.6 Set the Actuator's travel stops to the position required by the valve.
- 3.3.7 Set the override gearbox's travel stops to the same position as the actuator, and lock the setting.

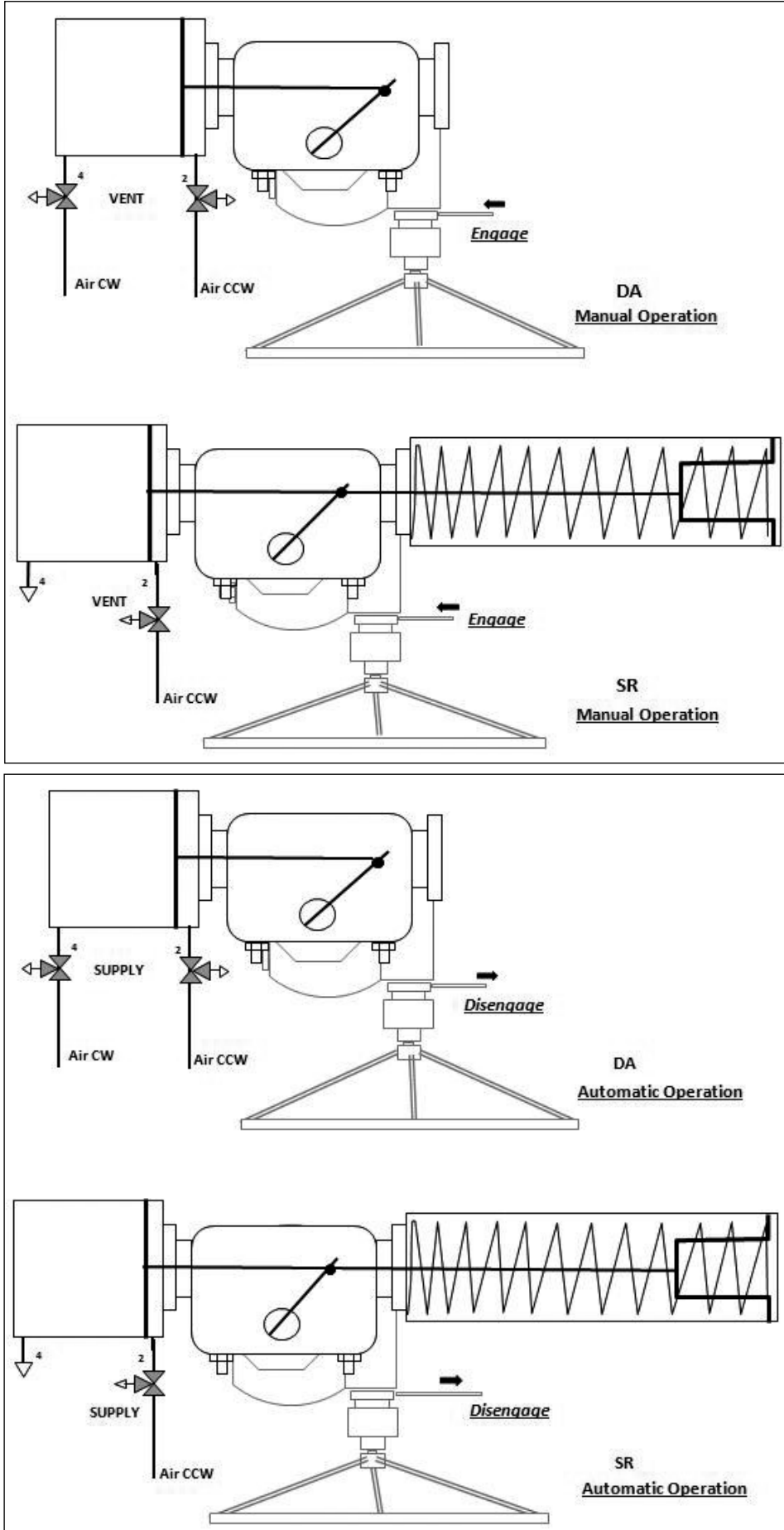

3.4 Operation

Manual Operation (In the absence of pneumatic pressure only)

- 3.4.1 Turn the 3 way valves on the pressure module to vent the cylinder ports to atmosphere. Ensure all vent valves are in vent position. Number of these valves varies as per the actuator type (DA/DD/SR).
 - 3.4.2 Rotate the hand wheel on the manual override until the position indicator on the manual override agrees with the valve position.
- !** ***NOTE: The position indicator on the manual override indicates actuator/valve position only when the hand wheel is engaged. (Position indicator shows 'SHUT' in full CW position and 'OPEN' in full CCW position)***
- 3.4.3 Engage worm shaft by pulling out the lock pin and rotate the engage-disengage lever 90 degrees till the spring loaded lock pin drops into the indexed position. Operate hand wheel to turn the gear override. Follow instructions on gearbox to engage the worm shaft.
 - 3.4.4 Manually operate the actuator by turning the hand wheel. See direction markings on the gearbox and turn the hand wheel accordingly to open/shut the valve.

3.5 Restoring Automatic Operation

- 3.5.1 Operate hand wheel to desired valve position. This should be fail safe position, for a spring return actuator.
- 3.5.2 Pull out the lock pin of the declutch mechanism, out of locking position, and turn the lever to Disengage the worm shaft from the wheel. Turn the lever until the lock pin sits into the indexed position. It may be necessary to rotate the hand wheel back & forth at the same time the declutching handle is lifted, to relieve the load on the declutching pin.
- 3.5.3 Turn the 3 way valves, on the pressure module ports to connect cylinder ports to air supply pressure.
- 3.5.4 Operate actuator normally with pneumatic pressure supply.

! ***CAUTION! The gearbox override on a spring return actuator shall not be disengaged while the spring is under compression. Engagement and disengagement of the worm shaft of the override gearbox should be done only at the Fail Safe condition of the actuator.***

4 Hydraulic Override

Hydraulic overrides on Automax heavy duty actuators provides a low effort, high thrust in compact sized override, for manually operating the actuator. The hydraulic overrides are single acting on the SR models and double acting on the DA actuator for efficient, automatic operation. These are available on models RG3 through RG8.

The hydraulic override consists of a power pack with hand operated high pressure pump connected by SS tubing, to hydraulic cylinder, mounted on spring module on SR models and on the torque module, on the DA models.

The hydraulic override provides adequate thrust to output the rated torque on DA models, and required valve torque output for the operation of SR models.

4.1 Installation

Automax standard hydraulic overrides are provided as a complete integral component of the heavy duty actuator. Hydraulic override is shipped with the cylinders mounted to the actuator and bypass/vent valves installed on the pressure cylinders. The power pack is selected, factory fitted and connected, as per the application. No additional customer installation is required. See Automax Heavy Duty IOM (FCD AXENIM0121) for instructions on installing Heavy Duty actuator into service.

4.2 Install hydraulic override onto existing heavy duty Spring Return actuator (see Fig.: 2)

- 4.2.1 Disconnect air pressure and electrical power from actuator.
- 4.2.2 Remove the end cover plate, retaining the O-ring on the Spring Module end.
- 4.2.3 Thread in the studs (1), from the override mounting kit, into the thrust base and insert the Hydraulic Cylinder into the Spring Module to mate the cylinder flange inner face to the thrust base, keeping the air venting plug to the top (see Fig.: 1).

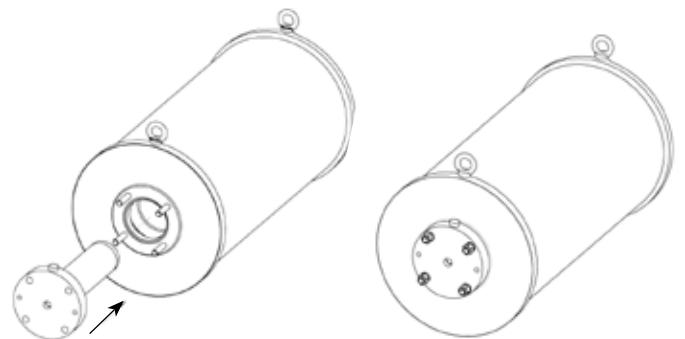

Fig.: 1 Insert Hydraulic Cylinder

Hydraulic Pressure Settings for SR Models, psi								
Model	Spring Module							
	1	2	3	4	5	6	7	8
RG3	1550	2000	2400	2850	3000	3000	3000	
RG4	1350	1580	1950	2200	2450	2900	3000	3000
RG5	1200	1680	2000	2300	2900	3000		
RG6	1000	1550	1900	2200	2500	2800		
RG7	1050	1750	2000	2350	2800	3000		
RG8	1150	1800	2300	2700	2900	3000		

Hydraulic MOP: 3000 psi

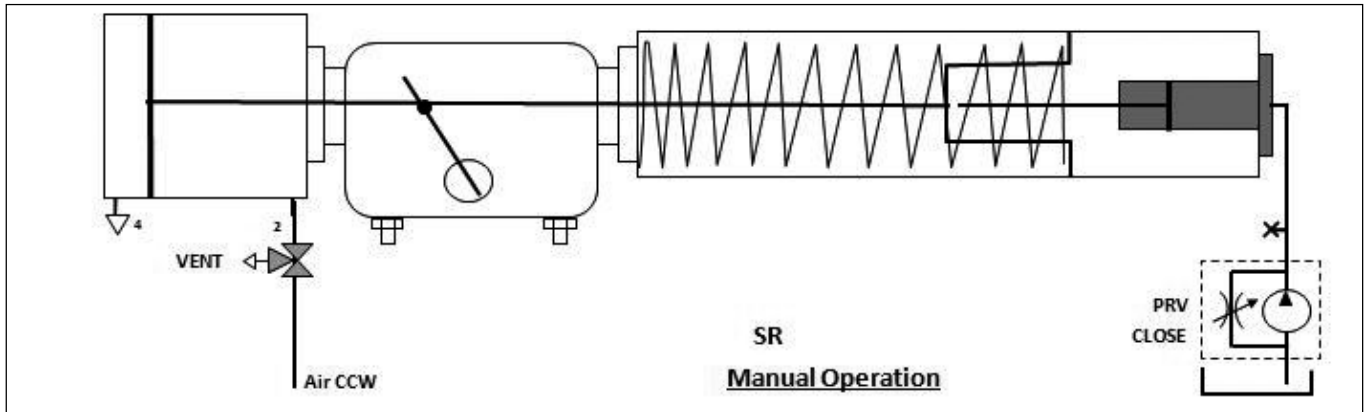

Fig.: 2 Install Hydraulic Override (SR)

- 4.2.4 Bolt up the cylinder flange on the thrust base of the Spring Module using the lock washers and nuts from override mounting kit.
- 4.2.5 Thread in the hydraulic connector into the cylinder port and connect it to the power pack, as per the schematic.
- 4.2.6 Fit the 3 way valves supplied in the mounting kit, to the pressure module's ports, as per the schematic.
- 4.2.7 Fill to level, hydraulic fluid (ISO 32 grade for general application) in the power pack reservoir, in the full retracted position of the piston.
- 4.2.8 Verify the maximum hydraulic pressure setting for the actuator model (refer table), close the pressure release valve on the pump and operate the hydraulic pump to start the ram movement. Lightly loosen the air vent screw on the cylinder flange to bleed off air from the hydraulic lines. The ram touches the Pull Rod's end face and pushes the pull rod, effecting the override.
- 4.2.9 Adjust the overload valve setting on the pump to ensure the pressure does not grossly exceed the Hydraulic pressure setting for the actuator, at the end of the stroke when the stopper bolt gets loaded.

4.3 Operation –SR Override

- 4.3.1 To operate the override, turn the 3/2 way valve on pressure module to vent the cylinder port to atmosphere and Close the pressure release valve, PRV (provided either externally or integral with the hand pump). Operating the Hand Pump on the power pack pushes the pull rod, compresses the spring and operates the valve.
- 4.3.2 Opening the pressure release valve, PRV releases the hydraulic pressure and the spring returns the actuator to fail safe state and the piston rod of override cylinder to retracted position.
- 4.3.3 To restore normal Automatic operation, turn the PRV to Open and switch the 3/2 way valve in position to connect cylinder port to air supply pressure.

4.4 Install hydraulic override on Standard DA heavy duty actuator

- 4.4.1 Remove the DA cover plate from the torque module and mount the DA hydraulic override cylinder assembly with the mounting kit and flange O-ring in the face groove.

Piston rod/pull Rod Torque									
Hex Size, A/F		18	18	24	30	36	46	65	85
	Tightning torque	ft Lb	30-35	35-45	50-60	60-75	75-85	100-140	175-200
kgm		4-5	4-5	7-8	8-10	10-12	13-19	24-28	28-33

- 4.4.2 Remove end cap of the hydraulic cylinder. With a suitable socket/tube spanner located on the hex head of the hydraulic piston end, thread in and tighten the piston rod into the threading of the Torque Module's Guide Block. Torque to values, as for pull rod/ piston rod.
- 4.4.3 Put back the end cap, taking care not to damage the cap seal, and tighten fully the tie rod nuts of the hydraulic cylinder.
- 4.4.4 Connect the ports of the hydraulic cylinder to the direction control valve on the hydraulic power pack. Refer schematic.
- 4.4.5 Check and ensure the Hydraulic pressure setting of the pump does not exceed the MOP setting, refer table below. Use the plugged port on the pressure line Tee, to connect a suitable pressure gage.

4.5 Operation –DA Override

- 4.5.1 For Manual Override operation, turn the 3 way valves on the pressure module to vent cylinder ports to atmosphere and Close the the hydraulic bypass valve, HBV (if provided externally). Close the pressure release valve on the pump. Turn the lever on the 4 way direction control valve on the power pack, to select the direction of the actuator rotation and stroke the hydraulic pump.
- 4.5.2 To restore Automatic operation, turn HBV to Open position, turn the vent valves to connect the cylinder ports to air supply pressure and open the pressure release valve on the hand pump.



CAUTION! Over thrust by the hydraulic override may cause actuator damage. Prevent damage and unsafe working, by adjusting the overload valve on the pump to limit the hydraulic pressure, as shown in the table.

DA Hydraulic Override Pressure for Rated Body torque						
Model	RG3	RG4	RG5	RG6	RG7	RG8
MOP, psi	1860	2100	2050	1950	1950	2150
Max. System Pr	2500 psi					

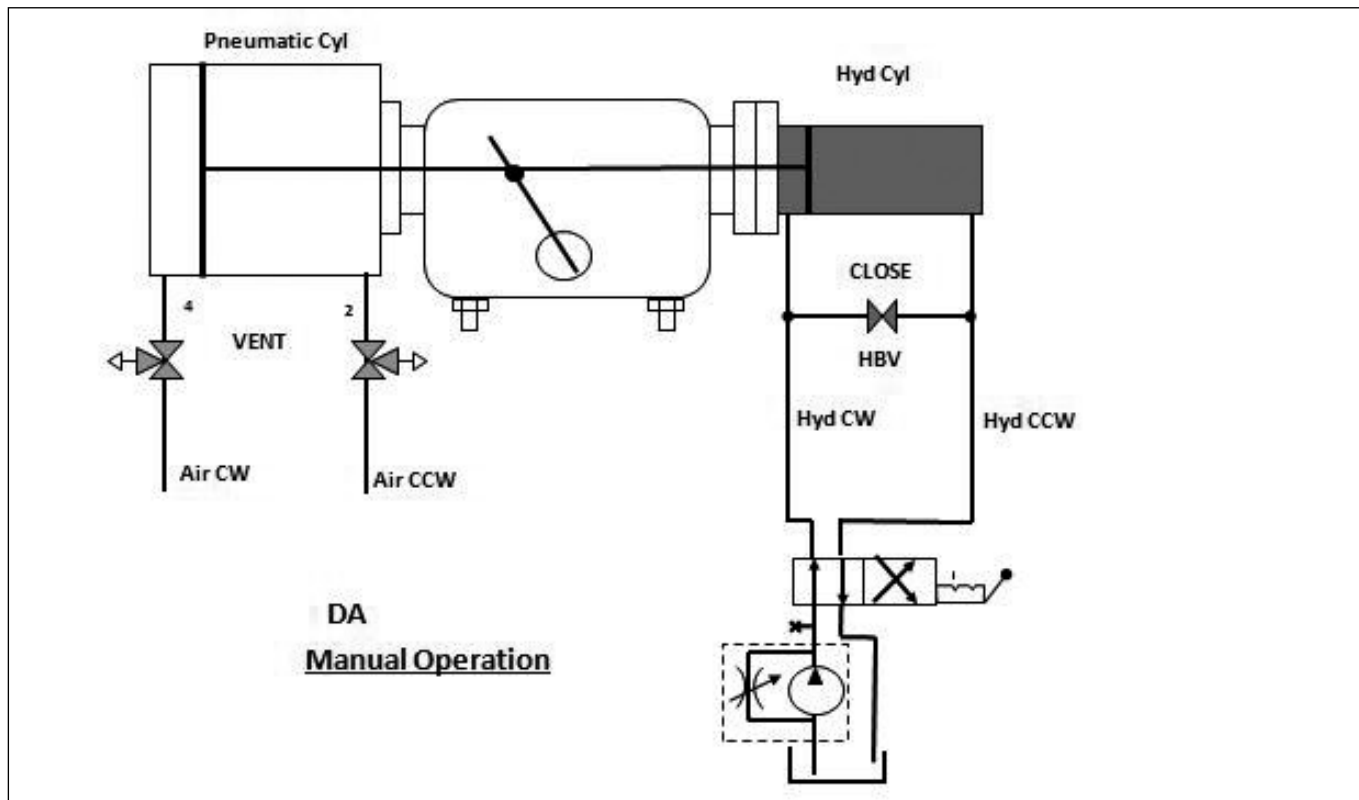
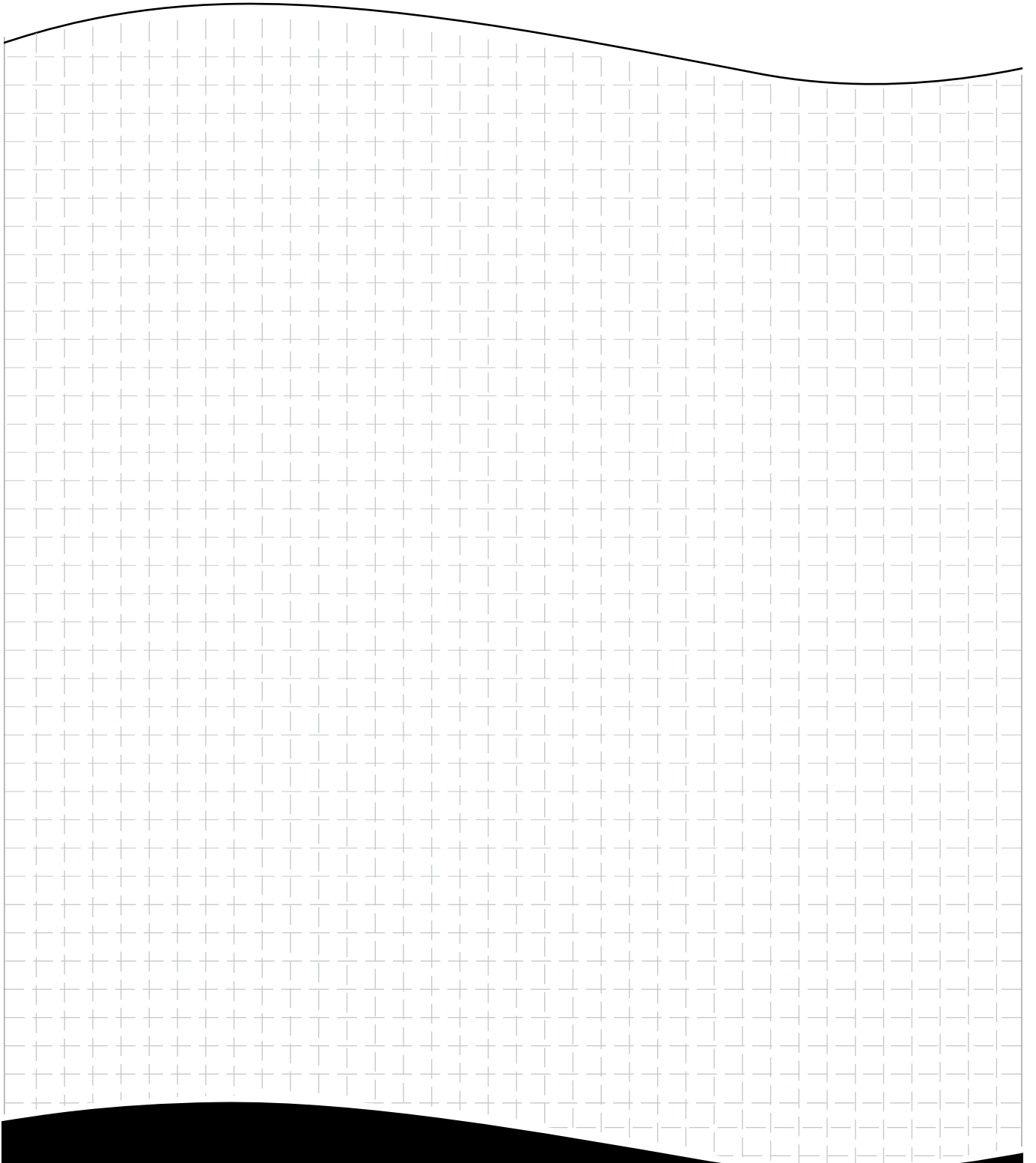

Fig.: 3 Install Hydraulic Override (DA)





Contact:



All data subject to change without notice

© ©12.2009 Flowserve Corporation. Flowserve and Kämmer are trademarks of Flowserve Corporation

Flowserve Corporation has established industry leadership in the design and manufacture of its products. When properly selected this Flowserve product is designed to perform its intended function safely during its useful life. However, the purchaser or user of Flowserve products should be aware that Flowserve products might be used in numerous applications under a wide variety of industrial service conditions. Although Flowserve can (and often does) provide general guidelines, it cannot provide specific data and warnings for all possible applications. The purchaser/user must therefore assume the ultimate responsibility for the proper sizing and selection, installation, operation, and maintenance of Flowserve products. The purchaser/user should read and understand the Installation Operation Maintenance (IOM) instructions included with the product, and train its employees and contractors in the safe use of Flowserve products in connection with the specific application.

While the information and specifications contained in this literature are believed to be accurate they are supplied for informative purposes only and should not be considered certified or as a guarantee of satisfactory results by reliance thereon. Nothing contained herein is to be construed as a warranty or guarantee, expressed or implied, regarding any matter with respect to this product. Because Flowserve is continually improving and upgrading its product design, the specifications, dimensions and information contained herein are subject to change without notice. Should any question arise concerning these provisions, the purchaser/user should contact Flowserve Corporation at any one of its worldwide operations or offices.

Flowserve Corporation
Flow Control Division
1978 Foreman Drive
Cookeville, Tennessee 38501 USA
Phone: +931 432 4021
Fax: +931 432 5518
www.flowserve.com

Flowserve Corporation
Flow Control Division
1350 North Mountain Springs Parkway
Springville, Utah 84663-0913 USA
Phone: +801 373 3028
Fax: +801 489 2228

Flowserve Pte Ltd
No. 12 Tuas Avenue 20
Singapore 638824
Phone: +65 6879 8900
Fax: +65 6862 4940

Flowserve Flow Control (UK) Ltd.
Burrell Road
Haywards Heath
West Sussex United Kingdom
RH16 1TL
Phone: +44 1444 314400
Fax: +44 1444 314401

Automax
Im groß Rohr 2
Limburg, Hessen 65549
Germany
Phone: +49 (0)6431 96610
Fax: +49 (0)6431 966130

Flowserve Ahaus GmbH
von-Braun-Str. 19a
48683 Ahaus
Phone: +49 2561 686-119
Fax: +49 2561 686-109

Flowserve Flow Control GmbH
Actuators and Automation Center
Germany
Rudolf Plank Str. 2
D-76275 Ettlingen
Germany
Phone +49 (0)7243 103 0
Fax +49 (0)7243 103 222

Flowserve Flow Control Benelux BV
Rechtzaad 17
4703 RC Roosendaal NB
Netherlands
Phone: +31 165 598 800
Fax: +31 165 555 670

Flowserve Australia Pty Ltd
Flow Control Division
14 Dalmore Drive
Scoresby, Victoria 3179
Australia
Phone: +61 3 9759 3300
Fax: +61 3 9759 3301

Flowserve S.R.L.
Via Prealpi 30
Cormano MI Italy I - 20032
Phone: +39 02 663251
Fax: +39 02 6151863

Flowserve do Brasil Ltda
Rua Tocantins, 128 - Bairro Nova Gerti
São Caetano do Sul,
São Paulo 09580-130 Brazil
Phone: +5511 4231 6300
Fax: +5511 4231 6329 - 423

Unit 01020607 9F
China Fortune Tower
No. 1568, Century Avenue, Pudong
Shanghai China 200122
Phone: +86 21 38654800
Fax: +86 21 50811781

Flowserve Corporation
No. 35, Baiyu Road
Suzhou Industrial Park
Suzhou 215021, Jiangsu Province,
PRC
Phone: +86-512-6288-1688
Fax: +86-512-6288-8737