

rotork[®]

Fluid Systems

EH Range

Technical Data

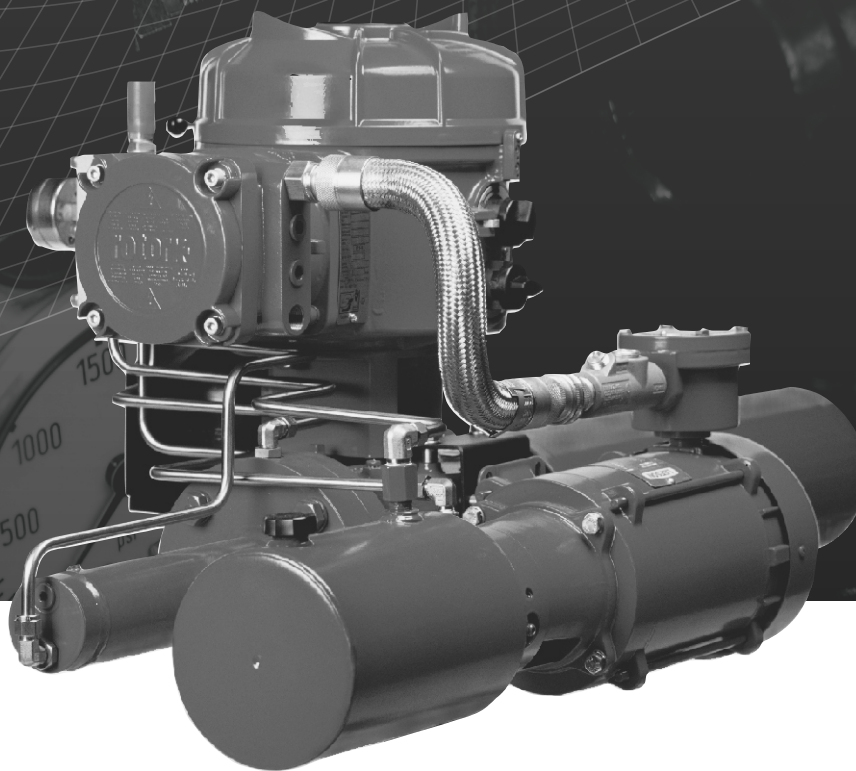

Electro-hydraulic
Valve Actuators

Redefining Flow Control

EH Range Technical Data

INTRODUCTION

The Rotork EH Range of self-contained, electro-hydraulic actuator includes an integrated control module; a hydraulic manifold; and a power unit consisting of a motor, hydraulic pump and reservoir. All electronics are protected in a watertight or explosion-proof enclosure. EH actuators are available in double-acting or spring-return configurations for both quarter-turn and linear applications. They can be configured to mount in any position, including remote mounting of the control module. Torque requirements up to 600,000 Nm (5.3 million lbf-in) and thrusts up to 5,500,000 N (1,2 million lbf) can be accommodated.

Other features include local manual control, indication feedback via dry contacts and 4-20 mA signal; or optional digital control via Modbus, Foundation Fieldbus, Profibus, DeviceNet or Rotork Pakscan communication systems. The EH Range can be supplied for operation with virtually any single phase, three phase, or 24 VDC power supply.

EH systems can also operated with an existing hydraulic power unit. The HPU must operate with compatible hydraulic fluid at pressures that do not exceed EH Range maximums. Consult Rotork Fluid Systems for sizing and application assistance.

Standard Features

- Self-contained system
- Non-intrusive set-up and interrogation via an Infra-red hand held remote
- Multiple input power options with either AC or DC supply
- Local position indication, diagnostics and fault indication via illuminated LCD display
- OPEN/CLOSE digital inputs and ESD (emergency shut down) input
- Positioning with a 4-20mA demand signal
- Partial stroke for OPEN/CLOSE configurations
- Water-tight or explosion-proof
- Manifold block simplifies control piping
- Lockable Local/Remote/Offline selector switch
- Local Open/Close selector switch
- Opto-isolated digital inputs
- Remote control disabled indication
- Separate, double sealed terminal compartment
- 4-20 mA position transmitter

Optional Features

- Hydraulic manual override pump
- Fast stroke options
- Hydraulic speed control
- Digital communication via Modbus, Foundation Fieldbus, Profibus, DeviceNet or Rotork Pakscan
- Solar power
- Accumulators
- Safety and reliability - suitable for SIL3 applications

GENERAL SYSTEM SPECIFICATION

Quarter-turn Torque Output 600,000 Nm (5.3 million inch pounds) Higher torques available upon request.

Linear Thrust Output 5.5 Million N (1.2 million pounds) Higher thrusts available upon request.

Standard EH Range linear actuators are available with stroke lengths up to 343mm (13.5in). Longer stroke lengths available upon request. Consult Rotork Fluid Systems.

Operating Pressure 170 bar (2500 psi) nominal
100 bar (1500 psi) nominal with accumulator

INPUT POWER

AC Voltages

3 Phase 50Hz: 190, 200, 220, 240, 380, 400, 415, 440, 480, 500, 525, 550, 660, 690
3 Phase 60Hz: 200, 208, 220, 230, 240, 380, 400, 440, 460, 480, 575, 600, 660, 690
1 Phase 50Hz: 110, 115, 220, 230, 240
1 Phase 60Hz: 110, 115, 208, 220, 230, 240

DC Voltages 24

Power Consumption

POWER CONSUMPTION (watts)		
	HOLDING	RUNNING
AC SYSTEMS	15	35 + motor power
DC SYSTEMS	6.5	12 + motor power

Where power consumption is a concern e.g., solar power, DC powered EH systems are available with holding - power ratings as low as 1.2 Watts. Contact Rotork Fluid Systems for low-power consumption requirements.

Tolerances AC: Voltage +/- 10%, Frequency 50/60Hz +/- 5%
DC: Voltage +/- 10%

EH Range Technical Data

SYSTEM OPERATION

Local Operation

LOCAL/REMOTE/OFFLINE selector switch
 OPEN/CLOSE switch
 Visual position indication via LCD display
 Optional hydraulic manual override

Remote Operation

Inputs

Run, Stop, Close, ESD and partial stroke
 Low voltage input: 20-60 VAC/VDC opto-isolated
 High voltage input: 60-120 VAC opto-isolated
 Minimum On voltage 17 VDC/VAC
 Maximum Off voltage 3 VDC/VAC
 Maximum Off current 100 μ A
 Minimum control signal 300 msec

Limit Switches

(2) SPDT, (4) SPDT optional

LIMIT SWITCH CURRENT RATINGS		
VOLTAGE	AC	DC
240	15 A	0.20 A
110	15 A	0.25 A
50	15 A	2.50 A
24	15 A	3.00 A

Output

4-20 mA position transmitter
 Zero adjustment 3.22 - 5.50 mA
 Span adjustment 17.70 - 34.34 mA
 Maximum total impedance must not exceed 500 Ω .

Positioning

Quarter-turn Cycle Rate: 100 starts/hr maximum
 Repeatability 0.5%, Linearity 1%
 Linear Cycle Rate: 200 starts/hr maximum
 Repeatability 0.5%, Linearity 5%
 Consult Rotork Fluid Systems for higher cycle rate requirements. Cycle rates over 1,200 starts/hour available.

Wiring Diagrams

WIRING DIAGRAMS		
	AC INPUT	DC INPUT
STANDARD	WD18170	WD18747
PAKSCAN	WD17984	WD18202
MODBUS	WD18204	WD18205
FOUNDATION F ⁺ BUS	WD18494	WD18206

Conduit Entries

(3) 1/2" NPT

ENVIRONMENT

Watertight and explosionproof configurations available.

Operating Temperatures

-20°C to 40°C (-4°F to 104°F).

Temperatures from -50°C to 60°C can be accommodated.

Contact Rotork Fluid Systems.

Environmental Protection

Control Enclosure	IP68
Motor	NEMA TEFC or IEC IP55, IP65 optional
Hydraulic Reservoir	IP54 (higher ratings available upon request)
Actuator	IP66, IP67M

Area Classifications

FM	3600 and 3615 Explosionproof Class I, Div. 1, Groups C, D Dust-ignitionproof Class II, Div. 1, Groups E, F, G
ATEX	EN50014 and EN50018 Flameproof II 2GD EEx d IIB T4
IEC	60079-0 and 60079-1 Flameproof Ex d IIB T4

GOST (Russia)

Additional approvals available

CSA	Explosionproof Class I, Div. 1, Groups C, D Dust-ignitionproof Class II, Div. 1, Groups E, F, G
-----	--

INMETRO (Brazil)



rotork®

Redefining Flow Control

www.rotork.com

A full listing of our worldwide sales and service network is available on our website.

Rotork plc
Brassmill Lane, Bath, UK
tel +44 (0)1225 733200
fax +44 (0)1225 333467
email mail@rotork.com

Scan with your smart phone
for more information on
this product range



PUB021-007-00
Issue 02/13

Formerly F711E. As part of a process of on-going product development, Rotork reserves the right to amend and change specifications without prior notice. Published data may be subject to change. For the very latest version release, visit our website at www.rotork.com
The name Rotork is a registered trademark. Rotork recognises all registered trademarks.
Published and produced in the UK by Rotork Controls Limited. ROWMH0213