

Pneumatic cylinder

- According to DIN 6432
- With magnetic piston
- Ø 8 to 25 mm

The pneumatic cylinders are equipped with magnetic piston and are available in the following versions

- double-acting with fixed end of stroke cushioning
- double-acting with adjustable end of stroke cushioning

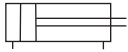

Note

Single acting on request

Technical data	
Materials	
Piston rod	Stainless steel AISI 303
Cylinder head	Aluminium, anodised
Cylinder tube	Stainless steel AISI 304
Seal material	PU
Control medium	lubricated or non-lubricated, filtered compressed air
Temperature range	-10...+80°C
Pressure range¹⁾	1...10 bar
Installation	User-defined

¹⁾ Pressure values [bar]: Overpressure with respect to atmospheric pressure

Force chart

Piston-diameter [mm]	Double-acting cylinder	
	Compressive force [N]	Tensile force [N]
8	27	20
10	42	36
12	61	46
16	109	93
20	170	142
25	265	223

Operating pressure 6 bar

The friction in the cylinder has been taken into account

Dimensions [mm] (according to DIN 6432)

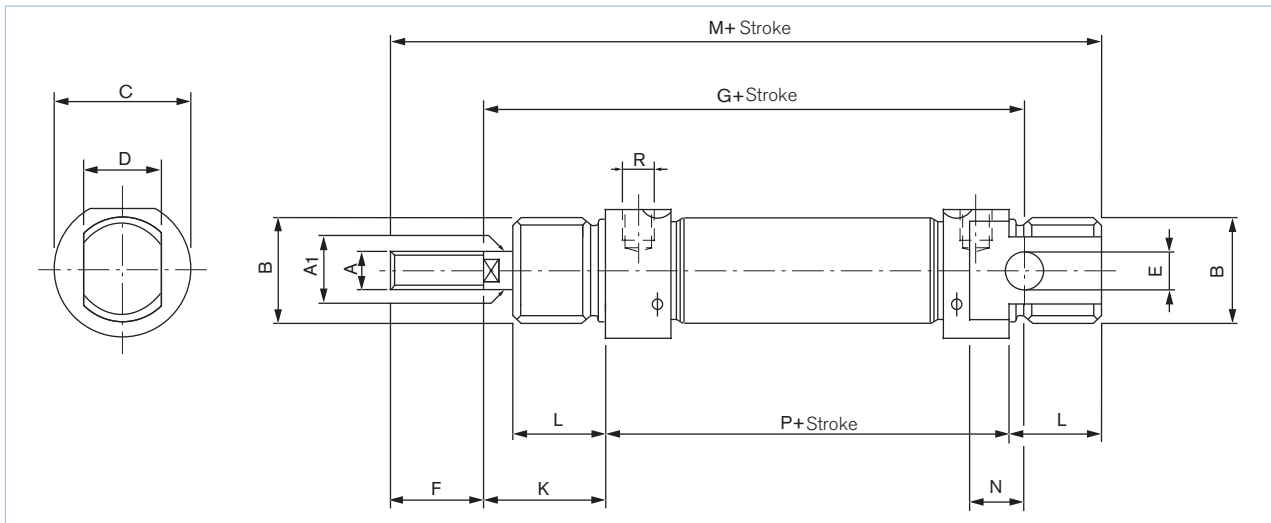

Piston diameter [mm]	A	A1	B	C	D	E	F	G	K	L	M	N	P	R
8	M4	4	M12 x 1.25	16	8	4	12	64	16	12	86	6	46	M5
10	M4	4	M12 x 1.25	16	8	4	12	64	16	12	86	6	46	M5
12	M6	6	M16 x 1.5	19	12	6	16	75	22	18	104	9	48	M5
16	M6	6	M16 x 1.5	19	12	6	16	82	22	18	109	9	53	M5
20	M8	8	M22 x 1.5	27	16	8	20	95	24	20	131	12	67	G1/8
25	M10 x 1.25	10	M22 x 1.5	30	16	8	22	104	28	22	140	12	68	G1/8

Ordering chart cylinder

Version ¹⁾	Piston diameter [mm]	Stroke [mm]	Item no. double-acting
With magnetic piston, with fixed end of stroke cushioning	008	10	780 573
		25	780 574
		50	780 575
		80	780 576
	010	10	780 581
		25	780 582
		50	780 583
		80	780 584
		100	780 585
	012	10	780 589
		25	780 590
		50	780 591
		80	780 592
		100	780 593
		125	780 594
		160	780 595
		200	780 596
	016	10	780 597
		25	780 598
		50	780 599
		80	780 600
		100	780 601
		125	780 602
		160	780 603
		200	780 604
	020	10	780 606
		25	780 563
		50	780 607
		80	780 608
		100	780 609
		125	780 610
		160	780 611
200		780 612	
025	10	780 615	
	25	780 616	
	50	780 617	
	80	780 618	
	100	780 619	
	125	780 620	
	160	780 621	
	200	780 622	

¹⁾ other versions on request

The delivery includes mounting and piston rod nut!

Ordering chart cylinder, continued

Version ¹⁾	Piston diameter [mm]	Stroke [mm]	Item no. double-acting
With magnetic piston, with adjustable end of stroke cushioning	16	25	782 989
		50	782 990
		80	782 991
		100	782 992
		125	782 993
		160	782 994
		200	782 995
	20	25	782 997
		50	782 998
		80	782 999
		100	783 000
		125	783 001
		160	783 002
		200	783 003
	25	25	783 006
		50	783 007
		80	783 008
		100	783 009
		125	783 010
		160	783 011
		200	783 012

¹⁾ other versions on request

The delivery includes mounting and piston rod nut!

Ordering instructions

For fasteners, please request data sheet Type TBU001. This includes:

- Head and floor flange fastening,
- Foot fastener, bearing support with rigid bearing,
- Joint head, as well as fork head
- Hexagon nut according to DIN 439.

Inductive limit switch, please see data sheet Type TEU005. Spare parts kits, please refer to the spare parts catalogue.

To find your nearest Bürkert office, click on the orange box →

www.burkert.com

If case of special conditions,
please consult for advice.

Subject to alteration.
© Christian Bürkert GmbH & Co. KG

1511/1_EU-en_00895296