

# SR100 (Pen Type) Hybrid Recorder

## Overview

The SR100 Hybrid Recorder is a pen-type recorder with an LCD digital display for easy reading of measured values.

This recorder has three modes for displaying measured values: 1-point digital display, multi-point batch digital display, and digital display + bar graph display.

Various settings for measurement and recording can be easily checked on the LCD digital display using the keys on the front panel.



## Features

### • SD card support

Equipped with a standard slot for SD cards (sold separately), which can be used to store data and write or read settings.

### • Full multi-range input

A total of 58 input ranges is standard equipment: 10 for DC voltage, 36 for thermocouples, and 12 for resistance thermometers.

Ranges can be freely set for each channel.

### • Easy data management using the communication function

The USB port enables direct connection to a PC.

Optional RS232C, RS422A, RS485, and Ethernet communication interfaces are available.

With an Ethernet interface, e-mail notifications of alarms can be sent, and settings can be changed remotely using a Web browser.

### • Comes with a software package

Data editing software for use on a personal computer allows data to be processed, in addition to easy recording and management.

Note: An optional communication interface is required.

Analysis software enables replay and display, waveform processing, editing, and trend display from recorded data files.

In addition, parameter setting software allows the user to manage settings from a PC.

### • Alarm display and printing functions are standard

Four types of alarms can be defined for each input port.

When an alarm is activated, "ALM" and the measured value begin flashing on the LCD operation screen.

### • End-of-chart detection function

Alarm actions upon detecting the end of the chart paper can be defined.

### • A variety of calculation functions

Measured data can be processed according to specified calculation settings, and the results of calculation can be displayed for each channel's displayed/recorded data.

## Specifications

<b>Input</b>	<b>Measurement point</b>	1st pen, 2nd pen, 3rd pen and 4th pen
	<b>Input type</b>	[DC voltage] ±13.8 mV, ±27.6 mV, ±69.0 mV, ±200 mV, ±500 mV, ±1 V, ±5 V, ±10 V, ±20 V, ±50 V [DC current] Supported by additional shunt resistor (100 Ω, 250 Ω) [Thermocouple] K, E, J, T, R, S, B, N, U, L, W-WRe26, WRe5-WRe26, PtRh40-PtRh20, NiMo-Ni, CR-AuFe, Platinel II, Au/Pt [Resistance thermometer] Pt100, old Pt100, JPt100, Pt50, Pt-Co
	<b>Accuracy rating</b>	Refer to the tables of measuring range, rated accuracy and display resolution.
	<b>Measuring interval</b>	Approx. 100 mS
	<b>Input resolution</b>	Approx. 1/40000 minimum (converted into reference range)
	<b>Input resistance</b>	Thermocouple/DC voltage (±5 V or lower range): 6 MΩ or higher DC voltage (±10 V or higher range): Approx. 1 MΩ
	<b>Burnout</b>	Signal disconnection judgment function for thermocouple/resistance thermometer input. None/UP/DOWN selected for each input CH for thermocouple and resistance thermometer.
	<b>Reference junction compensation accuracy</b>	Refer to the table of reference junction compensation accuracy.
	<b>Allowable signal source resistance</b>	[Thermocouple/DC voltage] Burnout disabled: 1 kΩ or lower Burnout enabled: 100 Ω or lower [Resistance thermometer] 10 Ω or lower per wire, the same resistance for 3 wires
	<b>Maximum input voltage</b>	Thermocouple/DC voltage (±5 V or lower range): ±10 V or lower DC voltage (±10 V or higher range): ±60 V or lower Resistance thermometer: ±6 V or lower
	<b>Measuring current</b>	Resistance thermometer: 1 mA ± 20 %
	<b>Maximum common mode voltage</b>	30 Vac/60 Vdc
	<b>Common mode rejection ratio</b>	130 dB or more (50/60 Hz)
	<b>Series mode rejection ratio</b>	50 dB or more (50/60 Hz)
<b>Terminal board</b>	Detachable	
<b>Recording specifications</b>	<b>Recording system</b>	Trace printing: disposable felt-tip pen Digital printing: dot type plotter pen
	<b>Recording color</b>	Analog recording/printing · · · 1 pen red, 2 pen green, 3 pen blue, 4 pen brown Digital recording/printing · · · purple
	<b>Digital recording/printing interval (SD card)</b>	0.1, 0.2, 0.5, 1, 2, 3, 5, 10, 15, 20, 30 sec 1, 2, 3, 5, 10, 15, 20, 30, 60 min
	<b>Recording interval</b>	100 ms
	<b>Step response</b>	90 % /1.0 sec
	<b>Chart</b>	Fan-fold type (total width 114 mm, total length 10 m, recordable width 100 mm)
	<b>Recording deadband</b>	0.2 %
	<b>Chart speed</b>	Set arbitrarily from 1 to 600 mm/h or 1 to 200 mm/m in 1 mm interval. 12.5 mm/h can be set exceptionally. Chart speed accuracy is in 0.1 % of the chart scale.
	<b>Chart fast-feed</b>	Operated by FEED key Feed 0.1mm by one quick press of the key or feed continuously (approx. 600 mm/min) by holding down the key.
	<b>Display/recording ON/OFF</b>	Select ON/OFF for trace printing to chart, digital printing to chart and recording to SD card for each CH.
	<b>Subtract printing</b>	Difference between reference CH value and measured value or between set value and measured value is printed.
	<b>Zone printing</b>	2 divisions
	<b>Compressed/expanded printing</b>	Chart recording lower/upper limit is made non-linear, and specific chart recording lower/upper limit is shrunk or expanded.
	<b>Automatic range-shift printing</b>	Recording range is shifted automatically to another set range when measured value exceeds the current range. Overlap function available
<b>Periodic data printing</b>	Digital printing is added to trace printing at (1) arbitrary intervals or (2) specified time. Printed items: Time, CH No., data and unit (1) Set interval and start time. Interval is limited by chart speed. (2) Set time for printing (24 points maximum)	

<b>Recording specifications</b>	<b>Data printing</b>	Printing format differs depend on the chart speed. Printed items are time, CH No., data and unit Consecutive requests are limited to a certain number.
	<b>Fixed time printing</b>	Date, time and time line, scale (ZERO/SPAN), CH No. & tag, and unit can be printed in conjunction with the chart speed. Year/month/date is printed instead of month/date when printed at every midnight. Tag is printed at the set time only.
	<b>Printing at power-on</b>	Date and time are printed at power-on.
	<b>Printing at recording start</b>	Date and time are printed at recording start (recording OFF → ON).
	<b>Alarm printing</b>	Alarm activation time, CH No., alarm type and level are printed at alarm activation. Reset time, CH No., hyphen and alarm level are printed at alarm reset. Up to 48 data can be memorized.
	<b>List printing</b>	List printing is performed when required, interrupting trace printing. Major setting information Date, time, chart speed and CH setting.
	<b>Message printing</b>	Printing is performed when required. Trace printing can be continued/interrupted. Linking to alarm activation/reset is possible. One message consists of up to 15 characters (alphabets, numbers, katakana, symbols, etc.). Up to 20 types can be registered. Consecutive requests are limited to a certain number.
	<b>Calendar timer printing</b>	Printing is performed with calendar timer ON and printing enabled. Trace printing is continued. Printed items: Year/month/date, time, calendar timer No. and message One message consists of up to 15 characters (alphabets, numbers, katakana, symbols, etc.), shared by message printing
	<b>Setting change mark</b>	Δ is printed on the right side of chart when setting change occurs.
	<b>Operation recording</b>	Remote contact ON/OFF status is recorded with straight line to specified area. Specified area: Within the range of 0 to 90% Up to 5 types can be recorded. * Only for the unit using remote contact and enabling operation recording.
	<b>Chart illumination</b>	White LED ON/OFF/AUTO (turn OFF after 3-minute unused period)
	<b>Chart end detection</b>	Notified on the operation window. Automatic recording stop (the rest operated normally)
	<b>Pen up function</b>	Performed automatically at recording stop and chart end. Manual pen up function is available.
<b>Time axis synchronization (POC)</b>	ON/OFF can be set at using 2nd pen, 3rd pen and 4th pen.	
<b>Indication/display specifications</b>	<b>Digital display</b>	Full dot monochrome LCD 240 x 48 dots Display area 106 x 16 mm White LED backlight (turned off after 3-minute unused period when selecting AUTO) Channel number: 2 digits Data display: 5 digits (+/- and decimal point excluded)
	<b>Analog indication</b>	100 mm LCD bar graph
	<b>Display items</b>	Measured values of all channels (displayed simultaneously), date (year, month, day), time (hour, minute), alarm occurrence channel, chart speed
	<b>Status LED</b>	(1) REC: Green LED OFF: Recording stopped Flash: Data printing, list printing and message printing in progress ON: Recording (2) CARD: Green LED OFF: No card inserted Flash: Card being accessed ON: Card inserted (3) ALM: Red LED OFF: All alarm OFF Flash: Any alarm ON
	<b>Operation/set keys</b>	FUNC1: Function switch 1 FUNC2: Function switch 2 ENTER: Register settings MENU: Display settings ESC: Cancel settings ▲ : Forward ▼ : Reverse ◀ : Move left ▶ : Move right REC: Recording start/stop FEED: Chart fast feed DATAP: Data print

<b>Alarm specifications</b>	<b>Display at alarm</b>	When alarm is activated, the “ALM” status LED and measured value of the channel generating the alarm will start flashing.		
	<b>Alarm type</b>	Upper limit alarm, Lower limit alarm, Difference upper limit alarm, Difference lower limit alarm, Rate-of-change upper limit alarm, Rate-of-change lower limit alarm		
	<b>Select level for setting</b>	1 to 4 /ch		
	<b>Alarm output</b>	Mechanical relay output Common to 'a' contact · · · 2 or 6 Mechanical relay output Common to 'c' contact · · · 4		
<b>Calculate specifications</b>	<b>Calculation types</b>	None, Root (square root), LOGe (natural logarithm), LOG10 (common logarithm), INT (integration), Humidity, COM.Input (data communications input), MUL (arithmetic 1), DIV (arithmetic 2), High-Peak (max value), Low-Peak (min value), Average, Power (exponent), Formula, BrokenLine (broken line approximation)		
	<b>Formula</b>	Calculate	Four arithmetic operations, Comparison operation, Logical operation, General calculation functions	
		Function	Integration, 24-hour integration, F value, Relative humidity, Dew-point temp, Moving average, First-order lag filter, Increment per unit time	
<b>General specifications</b>	<b>Rated power voltage</b>	100 to 240 Vac, 50/60 Hz		
	<b>Power consumption</b>	40 VA max .		
	<b>Memory protection</b>	Set contents maintained by nonvolatile RAM. Clock data maintained by lithium battery. (Data saved for more than 10 years with 8-hour or more operation per day.) (Alarm message displayed when battery level drops.)		
	<b>Clock accuracy</b>	±2 minutes in 30 days (under reference operating condition, error caused by power ON/OFF excluded)		
	<b>Insulation resistance</b>	Primary terminal – protective conductor terminal: 20 MΩ or more (500 Vdc) Secondary terminal – protective conductor terminal: 20 MΩ or more (500 Vdc) Primary terminal – secondary terminal: 20 MΩ or more (500 Vdc) * Primary terminal: General power terminal (100 to 240 V), alarm output terminal of mechanical relay “a” and mechanical relay “c” Secondary terminal: All terminals other than primary and protective conductor terminals		
	<b>Voltage resistance</b>	Primary terminal – protective conductor terminal: 1500 Vac (1 min) Secondary terminal – protective conductor terminal: 500 Vac (1 min) Primary terminal – secondary terminal: 2300 Vac (1 min) * Primary terminal: Power terminal, alarm output terminal Secondary terminal: All terminals other than primary terminals		
	<b>Exterior material</b>	[Front] Door: Aluminum die-casting Glass: Soda glass [Rear] Case: Cold-rolled steel plate		
	<b>Exterior color</b>	[Front] Door: Black (equivalent of Munsell N3.0) Glass: Clear and colorless [Rear] Case: Gray (equivalent of Munsell N7.0)		
	<b>Normal operating condition</b>	Ambient temperature	0 to 50 °C (20 to 65 %)	
		Ambient humidity	20 to 80 %RH (5 to 40 °C)	
		Power voltage	90 to 264 Vac	
		Power frequency	50/60 Hz ±2 %	
		Mounting posture	Forward tilt 0°, backward tilt 0 to 30°, left and right 0 to 10°	
	<b>Terminal screw</b>	Power terminal: M4.0 Protective conductor terminal: M4.0 Measuring input terminal: M3.5 Alarm output terminal: M3.5 Remote contact terminal: M3.5 Communications terminal: M3.0		
	<b>Weight</b>	Approx. 3.2 kg		
	<b>Mounting type</b>	Panel mounting Mounting brackets attached to the top and bottom sides		
	<b>Marking</b>	CE marking EN61326-1, EN61010-1		

<b>Option</b>	<b>External Operation</b>	Using remote contact signal (no-voltage contact: short or open), selection of chart speed or data printing can be executed without operating keys at the operation/set keys section.	
		Input points	5
		Input type	Non-voltage contact or open collector
		Outside point of contact capacity	5 Vdc/2 mA
		Functions	(1) Recording start/stop (2) Select chart speed from three speeds (3) Data printing (4) List printing (5) Message printing (6) Periodic (Date Interval) data printing (7) Integration value reset (8) SD card recording data-saving (9) Integration value reset (10) Time correction
<b>Alarm output</b>	Mechanical relay output Common to 'a' contact . . . 2 or 6 Max load      100 to 240 Vac 0.2 A 30 Vdc 0.2 A Minimum load 5 Vdc 10 mA		
	Mechanical relay output Common to 'c' contact . . . 4 Max load      100 to 240 Vac 0.2 A 30 Vdc 0.2 A Minimum load 5 Vdc 10 mA		
<b>Communication interface</b>	RS232C, RS422A, RS485, Ethernet		
<b>Communication protocol</b>	MODBUS(ASCII/RTU), MODBUS/TCP		
<b>Accessories</b>	<b>Item</b>	<b>Remarks</b>	<b>Q'ty</b>
	Instruction manual CD-ROM	-	1
	Instruction manual [Wiring/Installation]	-	1
	Brackets (for panel mounting)	-	2 (1 set)
	Terminal screw M3.5 (for input terminal)	-	5
	Folding chart (50 divisions)	<b>81406088-001</b>	1
	No.1 pen (Analog pen) Red (SR-101, SR-102, SR-103, SR-104)	-	1
	No.2 pen (Analog pen) Green (SR-102, SR-103, SR-104)	-	1
	No.3 pen (Analog pen) Blue (SR-103, SR-104)	-	1
	No.4 pen (Analog pen) Brown (SR-104)	-	1
Plotter pen (Digital pen) Purple	-	1	

## Example of recording

- Periodic (Data Interval) Data Printing

Data records are printed on the analog recording section at any desired interval.

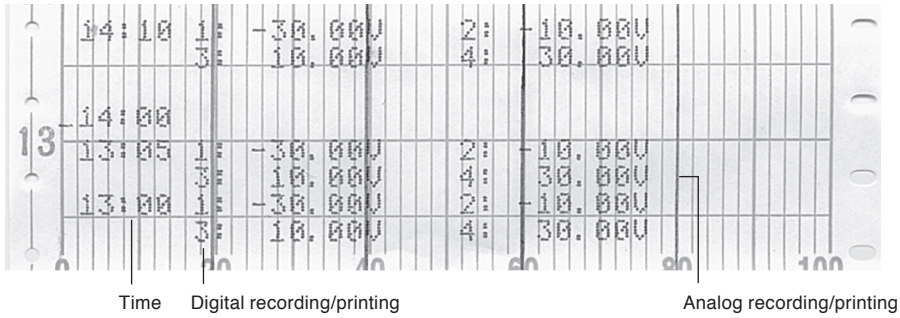

- List Printing

Settings such as the range and scale of each channel are printed.

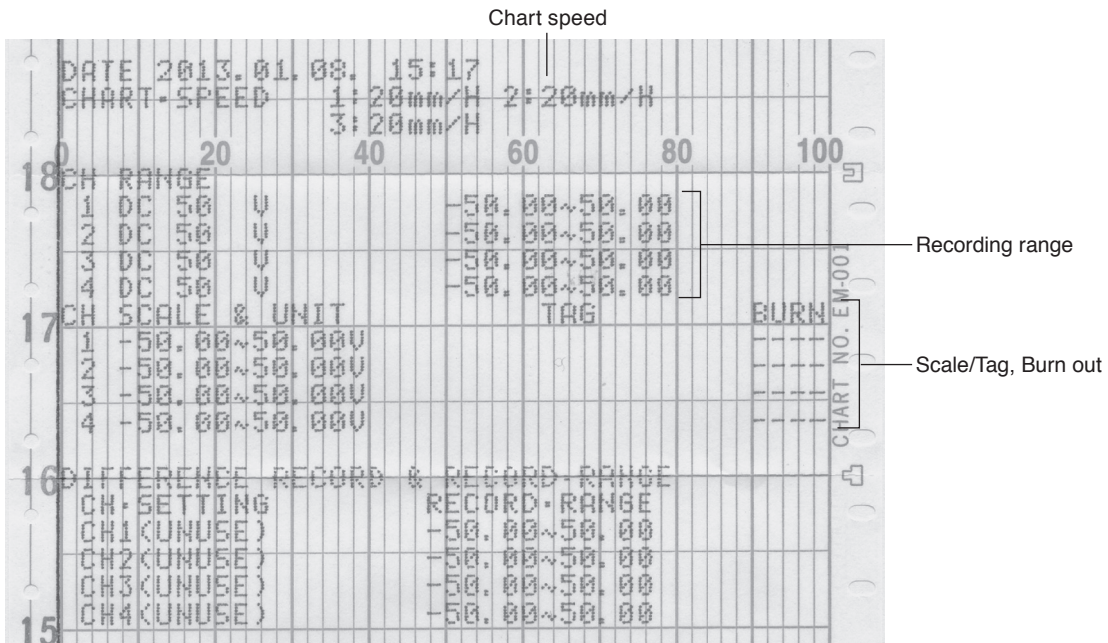

- Data print

If the latest data is required, analog recording immediately stops, and then the data record is printed.

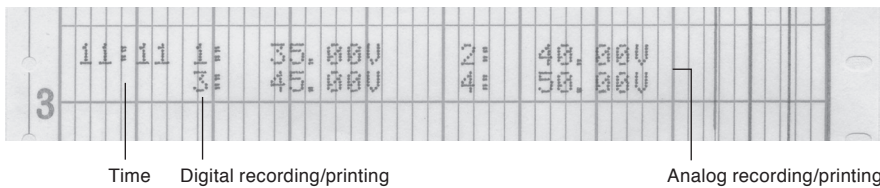

- Display and print at alarm activation/reset

When an alarm is activated or reset, the channel No., alarm type, and alarm point No. are printed.

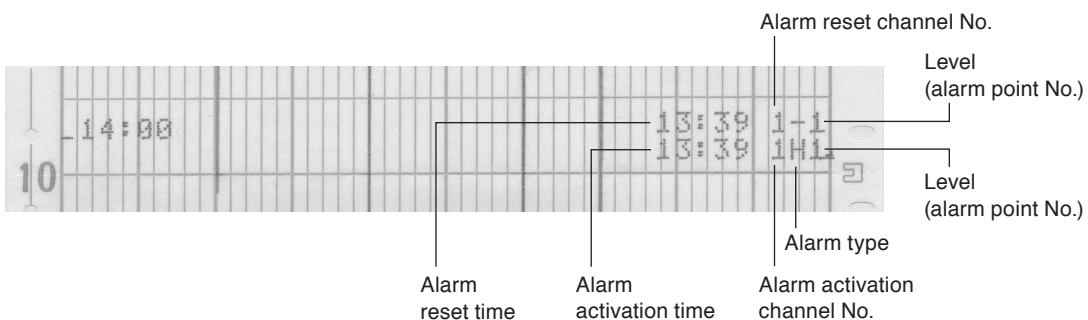

**Table : Measuring range, rated accuracy and display resolution**

Input type		Measuring range	Reference range	Rated accuracy	Display resolution	
DC voltage	DC ( mV)	-13.80 to +13.80 mV	±13.8 mV	±0.1 %FS ±1 digit	10 μV	
		-27.60 to +27.60 mV	±27.6 mV		10 μV	
		-69.00 to +69.00 mV	±69.0 mV		10 μV	
		-200 to +200 mV	±200 mV		100 μV	
		-500 to +500 mV	±500 mV		100 μV	
	DC (V)	-1 to +1 V	±1 V		10 mV	
		-5 to +5 V	±5 V		10 mV	
		-10 to +10 V	±10 V		10 mV	
		-20 to +20 V	±20 V		10 mV	
		-50 to +50 V	±50 V		10 mV	
Thermocouple	K	-200 to +300 °C	±13.8 mV	±0.1 %FS ±1 digit	0.1 °C	
		-200 to +600 °C	±27.6 mV		0.1 °C	
		-200 to +1370 °C	±69.0 mV		1 °C	
	E	-200 to +200 °C	±13.8 mV		0.1 °C	
		-200 to +350 °C	±27.6 mV		0.1 °C	
		-200 to +900 °C	±69.0 mV		1 °C	
	J	-200 to +250 °C	±13.8 mV		0.1 °C	
		-200 to +500 °C	±27.6 mV		0.1 °C	
		-200 to +1200 °C	±69.0 mV		1 °C	
	T	-200 to +250 °C	±13.8 mV		0.1 °C	
		-200 to +400 °C	±27.6 mV		0.1 °C	
	R	0 to 1200 °C	±13.8 mV		1 °C	
		0 to 1760 °C	±27.6 mV		1 °C	
	S	0 to 1300 °C	±13.8 mV		1 °C	
		0 to 1760 °C	±27.6 mV		1 °C	
	B	0 to 1820 °C	±13.8 mV		1 °C	
	N	-200 to +400 °C	±13.8 mV		±1 digit	0.1 °C
		-200 to +750 °C	±27.6 mV			0.1 °C
		-200 to +1300 °C	±69.0 mV			1 °C
	U	-200 to +250 °C	±13.8 mV		±1 digit	0.1 °C
		-200 to +500 °C	±27.6 mV			0.1 °C
		-200 to +600 °C	±69.0 mV			0.1 °C
	L	-200 to +250 °C	±13.8 mV		±1 digit	0.1 °C
		-200 to +500 °C	±27.6 mV			0.1 °C
		-200 to +900 °C	±69.0 mV			1 °C
	W-WRe26	0 to 2315 °C	±69.0 mV		±0.15 % ±1 digit	1 °C
	WRe5-WRe26	0 to 2315 °C	±69.0 mV		±0.15 % ±1 digit	1 °C
	NiMo-Ni	0.0 to 290.0 °C	±13.8 mV		±0.2 % ±1 digit	0.1 °C
		0.0 to 600.0 °C	±27.6 mV			0.1 °C
0 to 1310 °C		±69.0 mV	1 °C			
Platinel II	0.0 to 350.0 °C	±13.8 mV	±0.15 % ±1 digit	0.1 °C		
	0.0 to 650.0 °C	±27.6 mV		0.1 °C		
	0 to 1390 °C	±69.0 mV		1 °C		
PtRh40-PtRh20	0 to 1880 °C	±13.8 mV	±0.2 % ±1 digit	1 °C		
CR-AuFe	0 to 280 K	±6.9 mV	±0.2 % ±1 digit	0.1 K		
Au/Pt	0 to 1000 °C	±27.6 mV	±0.2 % ±1 digit	0.1 °C		
Resistance thermometer	Pt100	-140.0 to +150.0 °C	160 Ω	±0.1 % ±1 digit	0.1 °C	
		-200.0 to +300.0 °C	220 Ω		0.1 °C	
		-200.0 to +649.0 °C	340 Ω		0.1 °C	
		-200.0 to +850.0 °C	400 Ω		0.1 °C	
	Old Pt100	-140.0 to +150.0 °C	160 Ω		±0.1 % ±1 digit	0.1 °C
		-200.0 to +300.0 °C	220 Ω			0.1 °C
		-200.0 to +649.0 °C	340 Ω			0.1 °C
	JPt100	-140.0 to +150.0 °C	160 Ω		±0.1 % ±1 digit	0.1 °C
		-200.0 to +300.0 °C	220 Ω			0.1 °C
		-200.0 to +649.0 °C	340 Ω			0.1 °C
	Pt50	-200.0 to +649.0 °C	220 Ω		±0.15 % ±1 digit	0.1 °C
	Pt-Co	4.0 to 374.0 K	220 Ω		±0.15 % ±1 digit	0.1 K

\* Measuring range conversion accuracy under reference operating condition. Reference junction compensation accuracy is added for thermocouple input.

K, E, J, T, R, S, B, N:IEC584(1977, 1982), JIS C 1602-1995, JIS C 1605-1995

W-WRe26, NiMo-Ni, PlatinelII, PtRh40-PtRh20, CR-AuFe, Au/Pt:ASTM E1751 WRe5-WRe26:ASTM E988

U, L:DIN43710-1985 Pt100:IEC751(1995), JIS C 1604-1997 Old Pt100:IEC751(1983), JIS C 1604-1989, JIS C 1606-1989

JPt100:JIS C 1604-1981, JIS C 1606-1986 Pt50:JIS C 1604-1981 Pt-Co:CHINO

## ■ Escape clause of the precision rating

Input type	Escape clause range	Rated accuracy
K, E, J, N, U, L	-200 to 0 °C	±0.2 %FS ±1 digit or equivalent of 70 µV, whichever is large
T	-200 to 0 °C	±0.2 %±1 digit
R, S	0 to 400 °C	±0.2 %±1 digit
B	0 to 400 °C	None
	400 to 800 °C	±0.2 % ±1 digit
W-WRe26	0 to 400 °C	±0.3 % ±1 digit
PtRh40-PtRh20	0 to 400 °C	±1.5 % ±1 digit
	400 to 800 °C	±0.8 % ±1 digit
CR-AuFe	0 to 20 K	±0.5 % ±1 digit
	20 to 50 K	±0.3 % ±1 digit
Pt-Co	4 to 20 K	±0.5 % ±1 digit
	20 to 50 K	±0.3 % ±1 digit

## Model selection

I II III IV V VI VII

Ex. SR-101AN00NNN

I	II	III	IV	V	VI	VII	Discriptions
Model	Input point	Power	Communi-cations	Alarm output + remote contacts	Addition	Design code	
SR-1							100 mm chart recorder
	01						1 pen
	02						2 pen
	03						3 pen
	04						4 pen
		A					100 to 240 Vac
			N				None
			E				Ethernet
			R				RS232C
			A				RS422A/RS485
			Q				RS232C/RS485
			C				RS422A/RS485+RS485
			G				Ethernet+RS422A/RS485+RS485
				0			None
				2			2 mechanical relay 'a' contact alarm outputs
				4			4 mechanical relay 'c' contact alarm outputs + 5 remote contacts
				A			6 mechanical relay 'a' contact alarm outputs + 5 remote contacts
					0		None
					D		With inspection results
					Y		With traceability certification
					NNN	None	



## Consumables

### • About attached chart paper

Item	Item number	Remarks	Printed sca
Folding chart 50 divisions	81406088-001	10 books 16 m	0, 20, 40, 60, 80, 100
Folding chart 40 divisions	81425048-004	10 books 16 m	0, 10, 20, 30, 40 0, 20, 40, 60, 80 0, 50, 100, 150, 200 The above 3 patterns are printed.
Folding chart 50 divisions	81425048-001	10 books 16 m	0, 10, 20, 30, 40, 50 0, 20, 40, 60, 80, 100 0, 40, 80, 120, 160, 200 The above 3 patterns are printed.
Folding chart 60 divisions	81425048-002	10 books 16 m	0, 10, 20, 30, 40, 50 0, 20, 40, 60, 80, 100 0, 40, 80, 120, 160, 200 The above 3 patterns are printed.
Folding chart 70 divisions	81425048-003	10 books 16 m	0, 2, 4, 6, 8, 10, 12, 14
Folding chart 75 divisions	81425048-005	10 books 16 m	0, 50, 100, 150
Clean paper chart	81407115-001	10 books 12 m	0, 20, 40, 60, 80, 100

\* The chart paper has the same printed linear scale as the standard scale.  
Therefore, it can be shared in regardless of input types (thermocouple, resistance thermometer, or others).

### • Cartridge pen

Item	Item number	Quantity	Remark
Cartridge pen (analog pen) Red	SR-931CP000R	3 pieces	
Cartridge pen (analog pen) Green	SR-931CP000G	3 pieces	
Cartridge pen (analog pen) Blue	SR-931CP000B	3 pieces	
Cartridge pen (analog pen) Blue	SR-931CP000C	3 pieces	
Plotter pen (digital pen) Purple	81446296-001	3 pieces	

### • Resistor

Item	Item number	Quantity	Remark
250 $\Omega$ resistor (accuracy $\pm 0.02$ %)	81401325	1 resistors	
250 $\Omega$ resistor (accuracy $\pm 0.05$ %)	81446642-001	2 resistors	

### • SD card

Item	Item number	Quantity	Remark
SD card (512 MB)	SR-911SD0512	1	
SD card (1 GB)	SR-911SD1000	1	
SD card (2 GB)	SR-911SD2000	1	

## External dimensions

(Unit: mm)

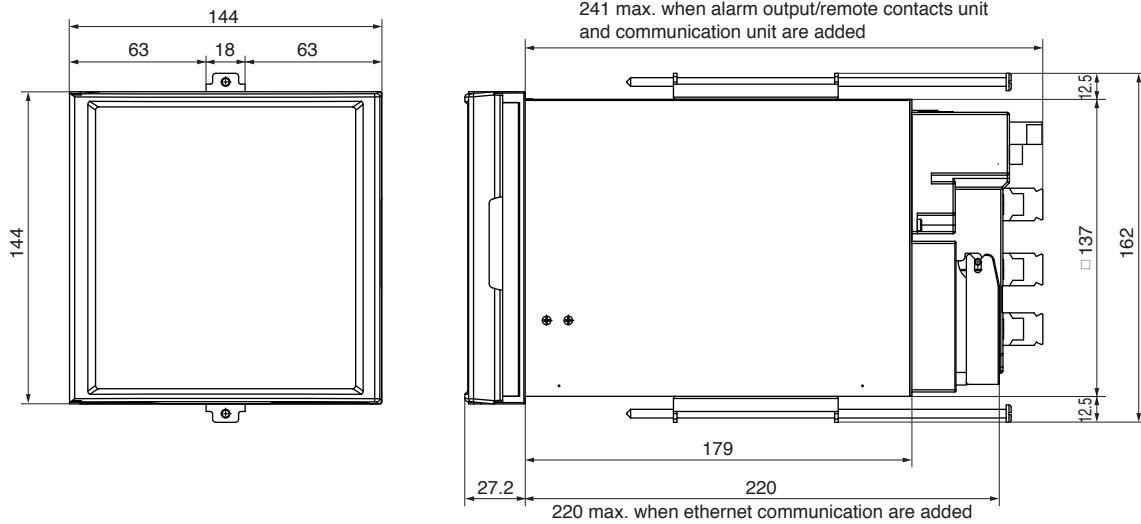

## Mounting

(Unit: mm)

### ● Minimum interval on multiple units mounting

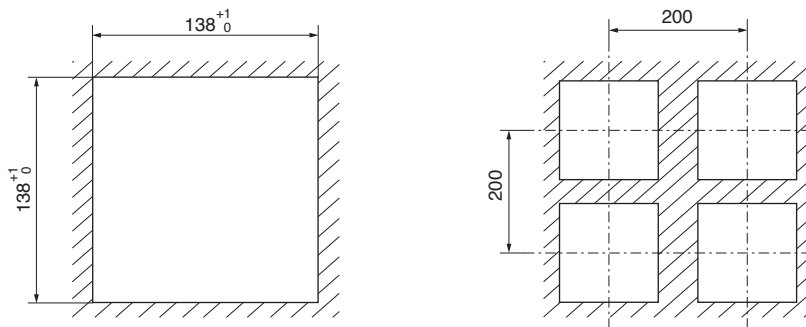

## Panel mounting method

Panel thickness  
(2 to 6 mm)

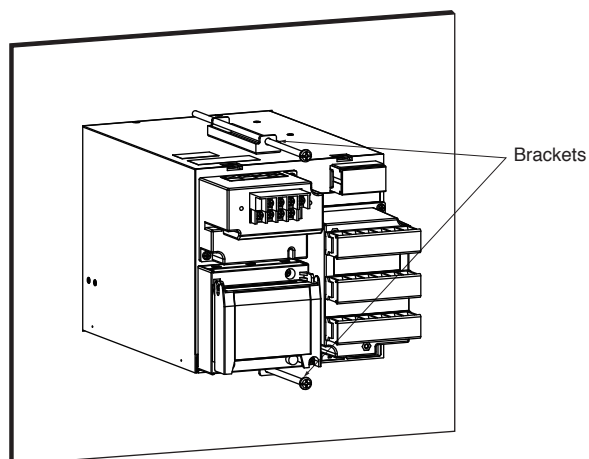

- (1) Insert the unit into the panel cutout from the front of the panel.
- (2) Fix the unit to the panel using the brackets (tightening torque: 1.0 Nm).  
Brackets are attached to the top and bottom surfaces.

## Wiring

■ The figure below is the diagram of the terminal board with the option [Alarm relay output (6 points 'a' contact) + remote contacts and communication interface].

Communications terminal (option)

	1	2	3	4	5	6	7	8
RS-232C				SG	SD		RD	
RS-422A				SG	SDA	SDB	RDA	RDB
RS-485	SA	SB	SG					

Measurement input terminal  
 TC · mV (+) RTD (A) terminal  
 TC · mV (-) RTD (A) terminal  
 RTD (B) terminal

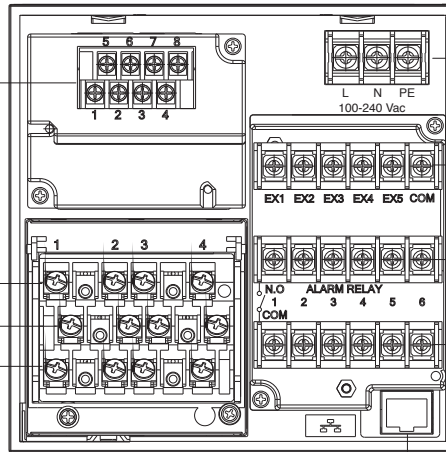

Power/protective conductor terminal

Remote contacts terminal (option)

Alarm output terminal (option)  
 N.O terminal

COM terminal

Ethernet

■ The figure below is the diagram of the terminal board with the option [Alarm relay output (4 points 'c' contact) + remote contacts (20 points) and communication interface].

Communications terminal (option)

	1	2	3	4	5	6	7	8
RS-232C				SG	SD		RD	
RS-422A				SG	SDA	SDB	RDA	RDB
RS-485	SA	SB	SG					

Measurement input terminal  
 TC · mV (+) RTD (A) terminal  
 TC · mV (-) RTD (A) terminal  
 RTD (B) terminal

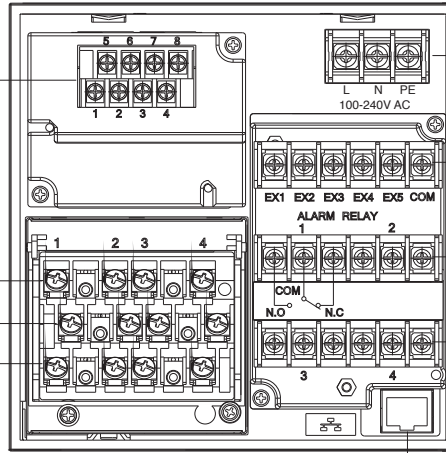

Power/protective conductor terminal

Remote contacts terminal (option)

Alarm output terminal (option)  
 N.O terminal

COM terminal

Ethernet

Please read the "Terms and Conditions" from the following URL before ordering or use:

<http://www.azbil.com/products/bi/order.html>

*Specifications are subject to change without notice.*

**azbil**

**[Sales agency]**

**Azbil Corporation**  
Advanced Automation Company

1-12-2 Kawana, Fujisawa  
Kanagawa 251-8522 Japan  
URL: <http://www.azbil.com/>

**[Manufacturer]**

**CHINO Corporation**

32-8 Kumano-cho, Itabashi-ku,  
Tokyo 173-8632 Japan

1st Edition: Issued in Feb. 2014  
2nd Edition: Issued in Sep. 2014

*No part of this publication may be reproduced or duplicated without the prior written permission of Azbil Corporation.*