

Vane Type Photoelectric Switches with Self-contained Amplifier

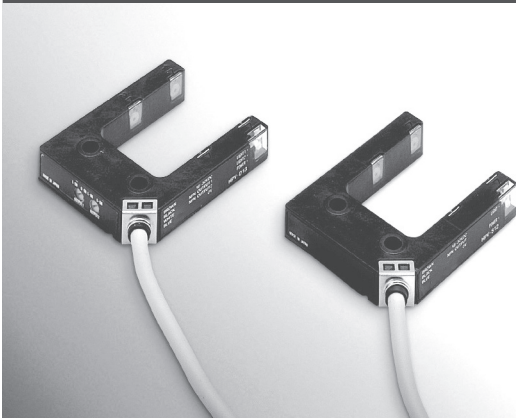

HPV Series

Switches with 2 optical axes in an easy-to-use size (vane width 25 mm, depth 35 mm) save space and reduce wiring.



- **Highly visible indicators**
(for power ON and incoming light)
- **Guaranteed down to -25°C for use in cold-storage warehouses**
- **The first optical axis position is located a mere 4 mm from the tip of the switch**
- **Small, light plastic case. (40 x 50 x 10 mm, 60/70 g)**
- **Sealed to IP64**
- **Operating mode can be set for individual axes with the L.O./D.O. selector switch (2-optical axis type)**
- **Can be gang-mounted**

TYPICAL APPLICATIONS

● The 2-optical axis type (HPV-D13) can detect both the deceleration and stop positions on stacker cranes and guided trolleys.

① 1-optical axis vane type photoelectric switch

Two switches are required, one for deceleration and one for stopping.

② HPV 2-optical axis switch

Just changing the dog shape as shown in (A) allows the same application as in ① on the left to be handled by one HPV switch.

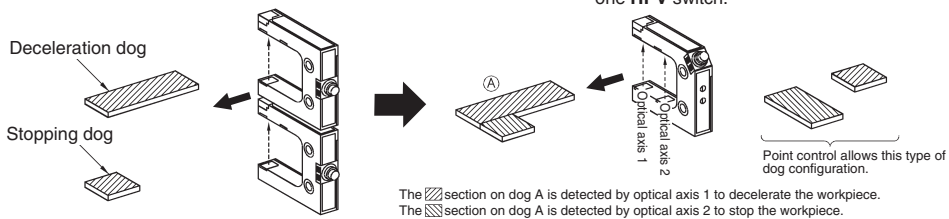

● Switches with 2 optical axes can be connected in series to read addresses. (In the following example for 8-bit addresses, an application with up to 256 addresses can be supported.)

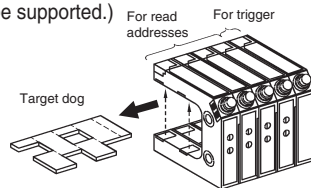

CATALOG LISTINGS

● Standard (preleaded) type with 2m code

Type	Detection method	Scanning distance	Operating mode	Input voltage	Output mode	Catalog listing	
						NPN open collector	PNP open collector
Optical axis 1	Thru scan (vane type)	Fixed at 25 mm	Light-ON	18 to 26.4 Vdc	NPN open collector	HPV-S11	
			Dark ON			HPV-S12	HPV-S22
Optical axis 2			Light-ON/Dark ON selectable			HPV-D13	HPV-D23

● Quick Lock type with 30cm code

Type	Detection method	Scanning distance	Operating mode	Input voltage	Output mode	Catalog listing	
						NPN open collector	PNP open collector
Optical axis 1	Thru scan (vane type)	Fixed at 25 mm	Light-ON	18 to 26.4 Vdc	NPN open collector	HPV-S11-035	
			Dark ON			HPV-S12-035	HPV-S22-035
Optical axis 2			Light-ON/Dark ON selectable			HPV-D13-035	

SPECIFICATIONS

Detection method	Thru scan (vane type)		
Number of optical axes	1		2
Catalog listing	HPV-S11	HPV-S12/HPV-S22	HPV-D13/HPV-D23
Input voltage	18 to 26.4 Vdc (ripple 10% max.)		
Current consumption	30 mA max.		40 mA max.
Scanning distance	25 mm (fixed)		
Target object	Opaque object 1 mm min.		
Operating mode	Light-ON	Dark-ON	Light-ON/dark-ON selectable by switch
Output mode	NPN transistor open collector/PNP transistor open collector		
Control output	Switching current: 100 mA max. (resistive load). Dielectric strength: 26.4V max. Voltage drop: 1V max. (at 100 mA switching current).		
Response time	1 ms max. for operation and recovery		
Light emitter	Infrared LED		
Indicators	Power (red when power ON). Incoming light (green when receiving).		
Ambient light immunity	Incandescent lamp: 3,000 lux max. Sunlight: 10,000 lux max.		
Operating temperature	-25 to +50°C		
Storage temperature	-30 to +70°C		
Humidity range	45 to 85% RH (condensation not allowed)		
Insulation resistance	Min. 20 MΩ(at 500 Vdc)		
Dielectric strength	1,000 Vac (50/60 Hz) for 1 minute between case and electrically live metal		
Vibration resistance	10 to 55 Hz, 1.5 mm peak-to-peak amplitude, 2hrs each in X, Y and Z directions		
Shock resistance	500 m/s ² , 10 times each in X, Y and Z directions		
Protective structure	IP64 (IEC standard)		
Wiring type	Prelead 2 m		
Weight	Approx. 60 g (with 2 m cable)		Approx. 70 g (with 2 m cable)
Circuit protection	Reverse connection protection circuit, Load short-circuit protection circuit		
Case material	PC/ABS alloy (black)		

EXTERNAL DIMENSIONS

(unit: mm)

● 1-optical axis type (HPV-S11, S12, S22)

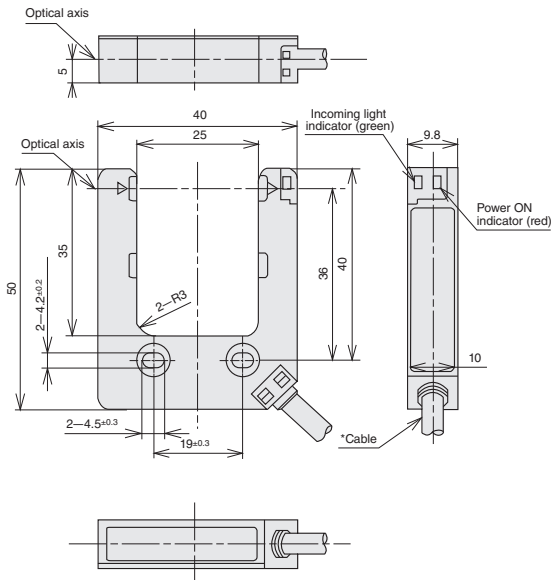

*Cable specifications: oil-proof, O.D. 4.2 mm, 3-core, nominal cross-sectional area 0.2 mm², sheath color gray.

● 2-optical axis type (HPV-D13, D23)

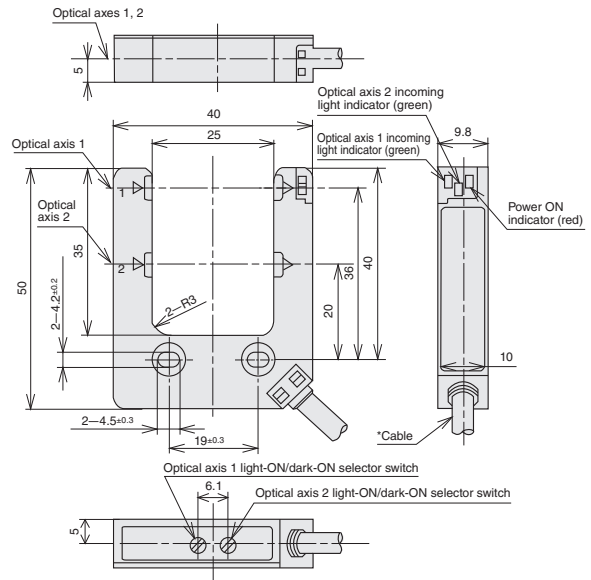

*Cable specifications: oil-proof, O.D. 4.2 mm, 4-core, nominal cross-sectional area 0.2 mm², sheath color gray.

● Bracket (HPV-B01) ··· order separately

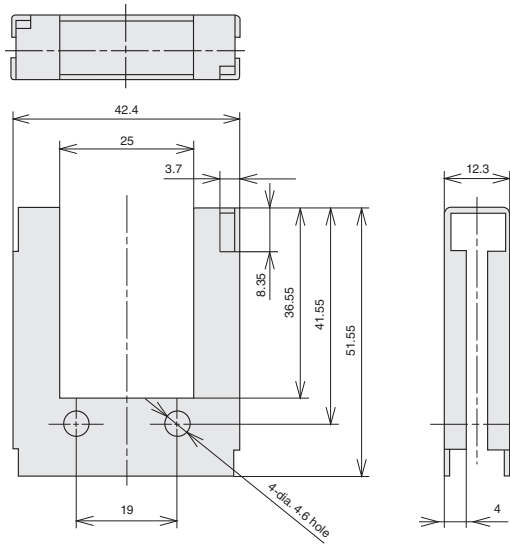

■ OUTPUT CIRCUIT

● 1-optical axis type (HPV-S11, S12)

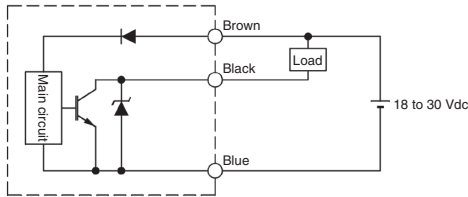

● 2-optical axis type (HPV-D13)

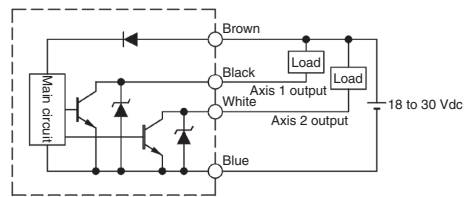

■ LIGHT-ON/DARK-ON SELECTOR SWITCH

On a 2-optical axis switches (HPV-D13), light ON and dark ON can be set independently for each optical axis.

* The default is dark-ON mode for both optical axes.

* Set the desired mode by the selector switches on the bottom of the case using the provided screwdriver.

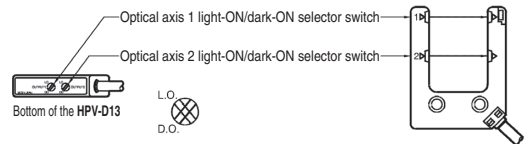

CONNECTOR WITH CABLE

Be sure to use a PA5 Series connector with cable when connecting a preleaded connector or connector-type switch.

● PA5 Series connector with cable

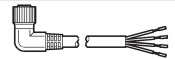
Shape	Power supply	Cord properties	Cord length	Catalog listing	Lead colors
	DC	Vinyl-insulated cord with high resistance to oil and vibration (UL/NFPA79 CM, CL3)	2 m	PA5-4I SX2SK	1: brown, 2: white, 3: blue, 4: black
			5 m	PA5-4I SX5SK	1: brown, 2: white, 3: blue, 4: black
			2 m	PA5-4I LX2SK	1: brown, 2: white, 3: blue, 4: black
			5 m	PA5-4I LX5SK	1: brown, 2: white, 3: blue, 4: black

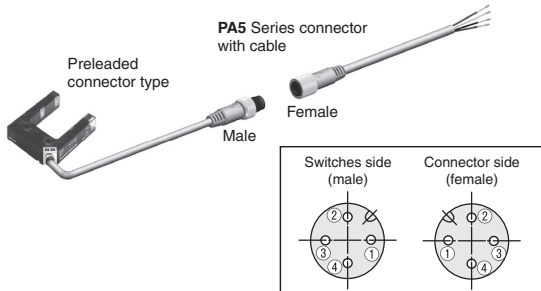

● Tightening the connector

Align the grooves and rotate the fastening nut on the PA5 connector by hand until it fits tightly with the connector on the switches side.

Switches side PA5 connector side

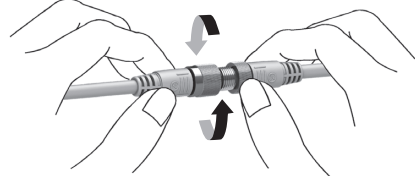

Be sure to use a PA7 Series connector with cable when connecting Quick Lock type switch.

● PA7 Series connector with cable

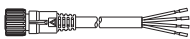
Shape	Power supply	Cord properties	Cord length	Catalog listing	Lead colors
	DC	Vinyl-insulated cord with high resistance to oil and vibration (UL/NFPA79 CM)	2 m	PA7-4I SX2SK	1: brown, 2: white, 3: blue, 4: black
			5 m	PA7-4I SX5SK	1: brown, 2: white, 3: blue, 4: black

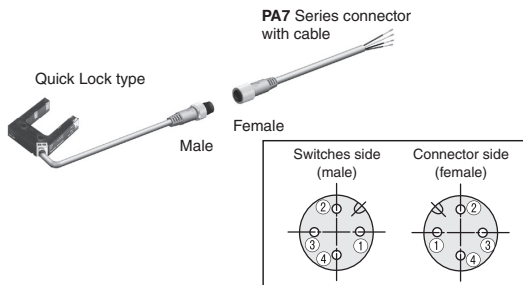

● Tightening the connector

Align the triangle mark and mate the male and female connector then rotate 45 degree to match the keys on the rings by hand.

Switches side PA7 connector side

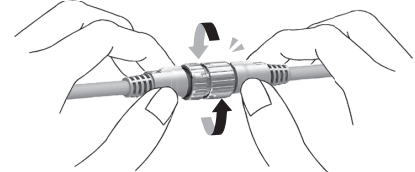

Interchangeable with Smartclick made by OMRON Corporation.

Smartclick  is trademark of OMRON Corporation.

BASIC PRECAUTIONS

1. Mounting

Firmly fix the case with two M4 screws tightened to a maximum torque of 0.5 N-m.

The switches can be gang-mounted as shown below.

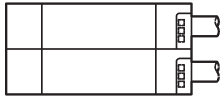

2. Mounting Space

When mounting the HPV, allow at least 3 mm of space for leading in the cable, as shown in figures A and B below. When mounting the HPV, allow at least 3 mm of space for leading in the cable, as shown in figures A and B below.

A.

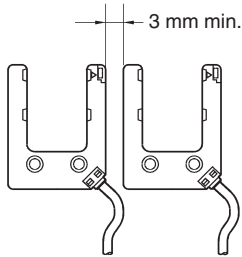

B.

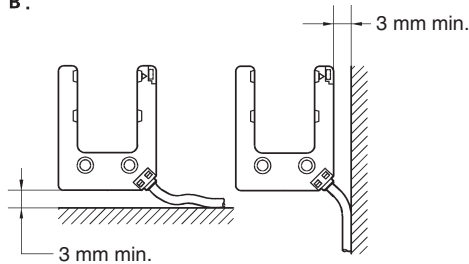

3. Wiring Precautions

- Be sure to wire the power supply and load for the photoelectric switch correctly.
- This photoelectric switch may be influenced by current surge or electrical noise if high-voltage lines or power lines are located near the photoelectric switch cable. To prevent this, route the cable separately from power lines, or put it in a separate conduit.
- Connect the leads securely using crimped terminals or the like.
- If extending the cable, use at least 0.3 mm² wire. Keep the cable length to within 100 m. Consider the influence of additional electrical noise caused by a longer cable.
- If a switched-mode power supply is used, ground the frame ground terminal on the power supply before use.
- When connecting a capacitive load, insert a current-limiting resistor to keep inrush current to 100 mA or less.

4. Handling Precautions

- Do not swing the photoelectric switch by its cable.
- Do not tug the photoelectric switch cable with excessive force. The maximum pullout strength of the cable is 50 N.
- Prevent objects from bumping against or scratching the switch head.
- Do not use this switch in a wet or oily place, or outdoors, or where exposed to chemicals (organic solvent, acid or alkali) atmospheres.
- Bends in the cable should have a radius of at least 30 mm.
- Standard cable might get hardened under 0°C. Do not bend or apply shock / vibration under 0°C. Low temperature cable is available.