

azbil



Gas Flow Monitor



**Superb Capability for
Air Ratio Control and
Energy Management of
Individual Burners**

The gas flow monitor is a compact, high-accuracy mass flow meter equipped with μF (Micro Flow) sensor chip. It accurately measures the mass flow rate at 0°C and one atmospheric pressure, with no effect against changes in temperature and pressure. The gas flow monitor offers a wide range of functions, such as instantaneous and integrated flow rate indication, and event output and analog output. In addition to its wide rangeability, The gas flow monitor is available in a variety of models for application to city gas 13A (LNG), air, butane and propane gases. It also supports air ratio control and energy management of burners.



City gas 13A (LNG), air, butane and propane gases

- A wide range of models available
- Low pressure loss makes it suitable in a wide range of burner applications



Proposing a next-generation gas flow meter

The application of a μ F (Micro Flow) sensor chip has enabled the development of a compact, high-accuracy gas flow meter.

Internal structure

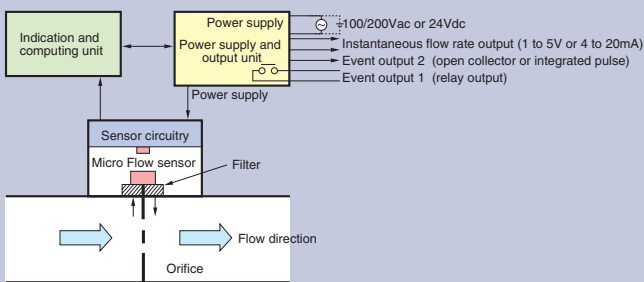

Excess air ratio

The amount of air needed for complete combustion is theoretically determined, and referred to as theoretical quantity of air. However, in actual combustion equipment, the theoretical quantity of air is insufficient for complete combustion. Therefore, excess air is used in order to sustain stable combustion and minimize heat loss due to exhaust gas, CO and particulate.

$$\text{Excess air ratio (m)} = \frac{\text{Quantity of air used (A)}}{\text{Theoretical quantity of fuel (AO)}}$$

Excess air ratio is generally set at $m=1.1$ or higher by burner adjustment. From knowing the gap in excess air ratio caused by dirt and dust on the burner and filter, the burner can be adjusted to realize optimum air ratio as well energy savings. According to energy conservation laws, the reference and target values of air ratio for energy saving are determined for each equipment.

Application

Energy management by equipment

[Merits]

- 200ms high speed response, even on ON-OFF control, provides accuracy in measurement and integration, and precisely monitors quantity of gas usage.

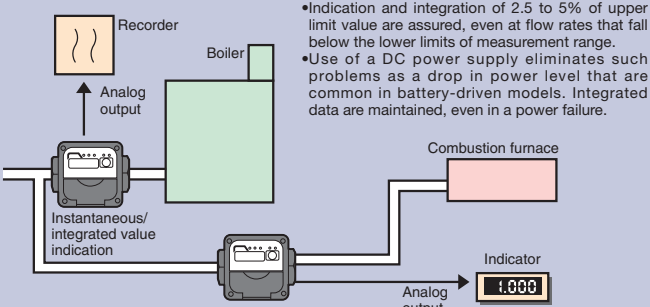

- Indication and integration of 2.5 to 5% of upper limit value are assured, even at flow rates that fall below the lower limits of measurement range.

- Use of a DC power supply eliminates such problems as a drop in power level that are common in battery-driven models. Integrated data are maintained, even in a power failure.

Flow rate monitoring for burner and pilot burner

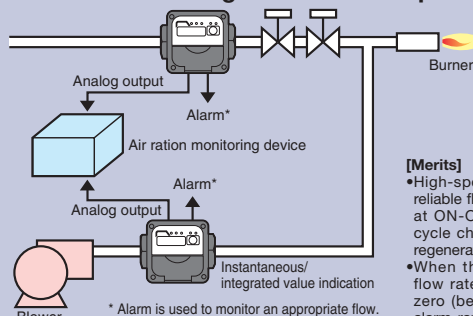

[Merits]

- High-speed response ensures reliable flow measurement, even at ON-OFF control and high-cycle changeover operation of regenerative burners.
- When the valve is OFF (zero flow rate) and the flow rate is zero (below the lower limit of alarm range), the contact alarm signal can be set to no output.

* Timing (1 to 30s) can be set for judging whether or not the increase in flow rate above the alarm setpoint is an actual condition for an alarm signal. Since momentary flow fluctuations can generate alarm signals, this function can prevent false alarms.

High-accuracy, high-speed response measurement

The gas flow monitor equipped with Micro Flow (μF) sensor realizes a compact body and high accuracy of $\pm 4\%$ RD. It also eliminates the need for correction of measured values generally affected by changes in temperature and pressure, due to its method of mass flow measurement.

Easy gas flow measurement and management

The gas flow monitor's digital indication of instantaneous / integrated flow rate is visible from a distance, and its measurement status can be indicated by Hi, Lo, OVER, ALARM LEDs.

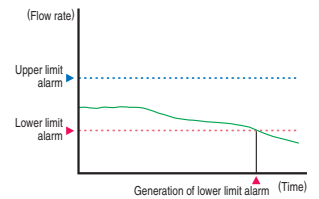

Other functions, for example, setting the upper limit and lower limit alarms, and using contact and analog signals as external outputs, are effective for flow management, such as monitoring quantity of fuel used.

Most suitable for burner applications

Because of its structure to minimize pressure loss, The gas flow monitor is the most suitable for burner applications that are sensitive to pressure loss.

Free directions for mounting and indication in any direction

Unlike conventional controllers, gas flow monitor does not require straight piping at upstream and downstream sides.*

Indication direction can also be changed, allowing easy mounting in any direction. (* Refer to Precautions item 5)

Compact body with IP54 protective structure

With a compact mask of 83.9X83.9mm and protective structure of IP54 (JIS C 0920), the CMG series can be installed without restrictions.

Self-diagnosis function

The self-diagnosis function is effective for troubleshooting.

Specifications

■ City gas 13A (LNG) and air models

Item	Contents								
Model No.	CMG150	CMG250	CMG400	CMG500					
Connection port	1/2 Rc	1 Rc	1 1/2 Rc	2 Rc					
Applicable gas	City gas (13A-46MJ), City gas (13A-45MJ) (Note 1), Air								
Measurement range m^3/h (normal)	0.5 to 4.0	1.0 to 10.0	3.0 to 30.0	8.0 to 80.0					
Indication range m^3/h (normal)	0.0 to 7.0	0.0 to 16.0	0.0 to 35.0	0.0 to 100.0					
Rated voltage	24V DC, 100V AC, 200V AC								
Flow indication method	Flow quality at 0°C and 1 atmospheric pressure conversion								
Sampling cycle	100ms $\pm 10\%$								
Ambient temperature	-10 to +60°C (no condensation allowed)								
Ambient humidity	90%RH at 40°C (no condensation allowed)								
Indication accuracy	Momentary flow indication accuracy: $\pm 4\%$ RD ± 1 digit (10 to 40°C) $\pm 6\%$ RD ± 1 digit (-10 to +60°C)								
Momentary flow output	1 to 5V DC output 4 to 20 mA output Output range: 0 to measurement range upper limit (changeable by parameter setting)								
Integral flow output	Measurement range: For decimal point 2-digit; Select either 0.001 m^3/h pulse or 0.01 m^3/h pulse For decimal point 1-digit; Select either 0.01 m^3/h pulse or 0.1 m^3/h pulse Output configuration: NPN open collector output								
Relay output	Contact (closes at an event generation) Contact rating: 250V AC, 30V DC, 5A (resistance load)								
Applicable pressure	Pressure code "0" model: 0 to 100 kPa (0 to 1bar) Pressure code "1" model: 0 to 1 MPa (0 to 10bar)								
Pressure resistance	Pressure code "0" model: 150 kPa max. (1.5bar max) Pressure code "1" model: 1.5 MPa max. (15bar max)								
Pressure loss (Note 2)	Thread	Flange	140 Pa	215 Pa	210 Pa	500 Pa	1300 Pa	285 Pa	550 Pa
Straight pipe length (cm)			-	-	-	500 Pa	1300 Pa	285 Pa	550 Pa
Protection	IP54 (JIS C 0920)								
Weight	Thread	850g	800g	2100g	2000g				

* User's manual No. : CP-SP-1113E

Note 1: City gas 13A is based on the gases shown below, which are produced from LNG. If the composition of your 13A is different, contact Azbil Corporation.

Gas type name	Calorific value (MJ)	Methane (%)	Ethane (%)	Propane (%)	Batane (%)
City gas 13A-46MJ	46.04655	88	5.8	4.5	1.7
City gas 13A-45MJ	45.007	88.9	6.8	3.1	1.2

■ Butane and propane models

Item	Contents							
Model No.	CMG150	CMG250	CMG400	CMG500				
Connection port	1/2 Rc	1 Rc	1 1/2 Rc	2 Rc				
Applicable gas	Butane gas (butane 75% + propane 25%), Propane gas (butane 98% + propane 2%)							
Measurement range m^3/h (normal)	Propane	0.20 to 2.00	0.40 to 4.00	1.00 to 10.00	2.5 to 25.00	5.0 to 50.00	2.5 to 25.00	5.0 to 50.00
Indication range m^3/h (normal)	Butane	0.10 to 1.00	0.30 to 3.00	0.80 to 8.00	2.0 to 20.00	4.0 to 40.00	2.0 to 20.00	4.0 to 40.00
Rated voltage	24V DC, 100V AC, 200V AC							
Flow indication method	Flow quality at 0°C and 1 atmospheric pressure conversion							
Sampling cycle	100ms $\pm 10\%$							
Ambient temperature	-10 to +60°C (no condensation allowed)							
Ambient humidity	90%RH at 40°C (no condensation allowed)							
Indication accuracy	Momentary flow indication accuracy: $\pm 6\%$ RD ± 1 digit at 10 to 40°C							
Momentary flow output	1 to 5V DC output 4 to 20 mA output Output range: 0 to measurement range upper limit (changeable by parameter setting)							
Integral flow output	Measurement range: For decimal point 2-digit; Select either 0.001 m^3/h pulse or 0.01 m^3/h pulse For decimal point 1-digit; Select either 0.01 m^3/h pulse or 0.1 m^3/h pulse Output configuration: NPN open collector output							
Relay output	Contact (closes at an event generation) Contact rating: 250V AC, 30V DC, 5A (resistance load)							
Applicable pressure	0 to 100 kPa (0 to 1bar)							
Pressure resistance	150 kPa max. (1.5bar max)							
Straight pipe length (cm)	-	-	15 min.	10 min.	40 min.	10 min.	40 min.	
Protection	IP54 (JIS C 0920)							
Weight	850g	800g	2100g	2000g				

* User's manual No. : CP-SP-1113E

Note 2: Pressure loss of 13A city gas is calculated by multiplying 0.64 specific gravity. (in the case of 13A city gas for the CMG150 model, the pressure loss is approx. 90 Pa. (140 Pa x 0.64 where 140 Pa is the pressure loss by air)

Selection Guide

■ City gas 13A (LNG) and air models

Example: CMG150A0041A0000

Table	Selection							Description		
I	Basic Model No.	CMG	↓	↓	↓	↓	↓	Gas flow monitor		
II	Piping size	15	○	–	–	–	–	15A (1/2B)		
		25	–	○	–	–	○	25A (1B)		
		40	–	–	○	○	–	○	40A (1.5B)	
		50	–	–	○	○	–	○	50A (2B)	
III	Piping type	0	○	○	○	–	○	Rc thread		
		1	–	–	–	○	–	–	JIS 10K flange	
IV	Gas type	A	○	○	○	○	○	Air		
		N	○	○	○	○	–	–	City gas 13A 46MJ (LNG)	
		G	○	○	○	○	–	–	City gas 13A 45MJ (LNG)	
		004	○	–	–	–	–	–	4 m ³ /h (normal)	
V	Flow range	010	–	○	–	–	–	10 m ³ /h (normal)		
		030	–	○	–	–	○	30 m ³ /h (normal)		
		080	–	–	○	○	–	○	80 m ³ /h (normal)	
		150	–	–	○	○	–	○	150 m ³ /h (normal)	
		0	○	○	○	○	–	–	1 to 5V DC	
VI	Output	1	○	○	○	○	○	4 to 20 mA + event		
		0	○	○	○	○	–	–	Low (0 to 100 kPa)	
VII	Pressure	1	–	–	–	○	○	Medium (0 to 1 MPa)		
		0	○	○	○	○	○	○	None	
VIII	Communication	0	○	○	○	○	○	None		
IX	Power	0	○	○	○	○	–	–	24V DC	
		1	○	○	○	○	○	○	100V AC (50/60Hz)	
		2	○	○	○	○	○	○	200V AC (50/60Hz)	
X	Option	00	○	○	○	○	○	○	None	
		D0	○	○	○	○	○	○	○	Inspection certificate provided
		Y0	○	○	○	○	○	○	○	Traceability certificate provided

■ Butane and propane models

Example: CMG150P0021A0000

Table	Selection							Description		
I	Basic Model No.	CMG	↓	↓	↓	↓	↓	Gas flow monitor		
II	Piping size	15	○	–	–	○	–	–	15A (1/2B)	
		25	–	○	–	–	○	–	25A (1B)	
		40	–	–	○	○	–	○	40A (1.5B)	
		50	–	–	○	○	–	○	50A (2B)	
III	Piping type	0	○	○	○	○	○	Rc thread		
IV	Gas type	B	○	○	○	–	–	–	Butane	
		P	–	–	–	○	○	○	Propane	
V	Flow range	001	○	–	–	–	–	–	1 m ³ /h (normal)	
		002	–	–	–	○	–	–	2 m ³ /h (normal)	
		003	–	○	–	–	–	–	3 m ³ /h (normal)	
		004	–	–	–	–	○	–	4 m ³ /h (normal)	
		008	–	○	–	–	–	–	8 m ³ /h (normal)	
		010	–	–	–	–	○	–	10 m ³ /h (normal)	
		020	–	–	○	–	–	–	20 m ³ /h (normal)	
		025	–	–	–	–	–	○	25 m ³ /h (normal)	
		040	–	–	○	–	–	–	40 m ³ /h (normal)	
		050	–	–	–	–	–	○	50 m ³ /h (normal)	
VI	Output	0	○	○	○	○	○	○	1 to 5V DC	
		1	○	○	○	○	○	○	4 to 20 mA + event	
VII	Pressure	0	○	○	○	○	○	○	0 to 100 kPa (0 to 1bar)	
VIII	Communication	0	○	○	○	○	○	○	None	
IX	Power	0	○	○	○	○	○	○	24V DC	
		1	○	○	○	○	○	○	100V AC (50/60Hz)	
		2	○	○	○	○	○	○	200V AC(50/60Hz)	
X	Option	00	○	○	○	○	○	○	None	
		D0	○	○	○	○	○	○	○	Inspection certificate provided
		Y0	○	○	○	○	○	○	○	Traceability certificate provided

Dimensions

(unit:mm)

• CMG150/250

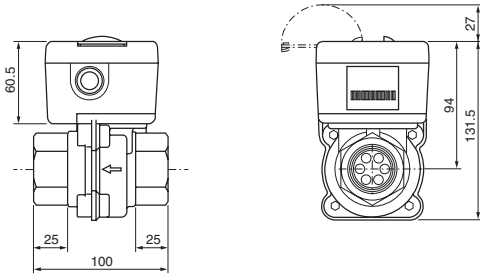

• CMG400/500

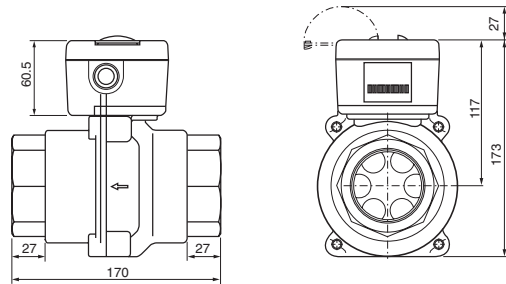

Precautions

1. Install this unit at the upstream side of safety shutoff valve in the gas flow piping line. Explosive gases mixed with air should not enter the piping, as a lighting discharge causes sparks to ignite and an explosion might occur. In case of applied excessive voltage or a power short-circuit, the unit is protected by an internal safety circuit and fuse.
2. This unit is designed for gas and air as indicated by model number. Do not use for any other gases. If this unit is used for a gas of which ignition temperature is lower than that of the indicated gas, and if an explosive gas mixed with air enters the piping, an explosion might occur due to the build-in heater in the sensor.
3. The use of a strainer is required in the gas flow line on the upstream side

- of this unit to prevent rust occurring or foreign matter entering. If a foreign matter enters the piping, an operation failure might occur.
4. If this unit is used outdoors, protection from direct sunlight and rain is needed.
5. The CMG250 (30m³/h(normal) type) and CMG400/500 series have a larger hole in the main flow orifice to enable larger flow. Therefore, if there is no straight piping area, the flow rate in the bypass becomes unstable, resulting in a decline of accuracy of 8 to 10%. In order to maintain 4% accuracy, the inlet side straight pipe length must be 15cm or longer for the CMG250 (30m³/h(normal) type) and 10cm or longer for the CMG400/500 series.

Please read the "Terms and Conditions" from the following URL before ordering or use:

<http://www.azbil.com/products/bi/order.html>

[Notice] Specifications are subject to change without notice.

No part of this publication may be reproduced or duplicated without the prior written permission of Azbil Corporation.

Other product names, model numbers and company names may be trademarks of the respective company.

Azbil Corporation

Advanced Automation Company

Yamatake Corporation changed its name to Azbil Corporation on April 1, 2012.

1-12-2 Kawana, Fujisawa
Kanagawa 251-8522 Japan

URL: <http://www.azbil.com>

1st Edition : Issued in Mar. 2003-MO
8th Edition : Issued in Nov. 2012-AZ