

# Connector with cable

## PA7 Series

Quick-lock connector connects with a 1/8 turn of the lock ring, enabling significant reduction of wiring labor.

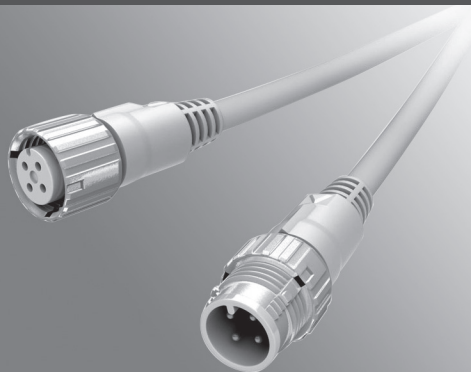

- Freedom from wiring and crimping work, reduction of man-hours
- Compatible with M12 threaded connectors
- Connect it with just 1/8 turn. Clicks into place, so you know it's connected.
- NFPA79-compliant cable (CM)

Compatible with OMRON Smartclick connectors.

Smartclick is a registered trademark of OMRON Corporation.

### CATALOG LISTING CODE

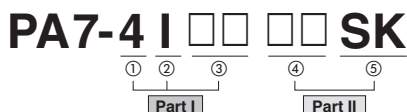

Part I \ Part II	03SK	05SK	1SK	2SK	3SK	5SK	10SK
PA7-4ISX			○	○	○	○	○
PA7-4IBX	○	○	○	○	○	○	○
PA7-4ISB		○	○	○	○	○	○

Part I	①	Cores	4	4
	②	For AC/DC use	I	DC
	③	Connector type	BX	Cable with 1 male connector
Part II	④	Cable length	SX	Cable with 1 female connector
			SB	Cable with male and female connectors
			03	0.3 m
			05	0.5 m
			1	1 m
			2	2 m
			3	3 m
			5	5 m
			10	10 m
			⑤	Cable type

### CATALOG LISTING

Power supply	Cable type	Connector type	Cable exit direction	External diameter (mm)	Number of cores	Conductors (mm <sup>2</sup> )	Cable length (m)	Catalog listing
DC	Vinyl insulated cable with high oil & vibration resistance UL/NFPA79 CM	Female	Straight	6 dia.	4	0.5 (110/0.08)	1	PA7-4ISX1SK
							2	PA7-4ISX2SK
							3	PA7-4ISX3SK
							5	PA7-4ISX5SK
							10	PA7-4ISX10SK
		Male & female	Straight, straight				1	PA7-4ISB1SK
							2	PA7-4ISB2SK
							3	PA7-4ISB3SK
							5	PA7-4ISB5SK
							10	PA7-4ISB10SK

Power supply	Cable type	Connector type	Cable exit direction	External diameter (mm)	Number of cores	Conductors (mm <sup>2</sup> )	Cable length (m)	Catalog listing
DC	Vinyl insulated cable with high oil & vibration resistance UL/NFPA79 CM	Male	Straight	6 dia.	4	0.5 (110/0.08)	0.3	PA7-4IBX03SK4*

\* For delivery date of this product, contact a branch or sales office.

\* Terminals: for M4 (φ 4 terminals)

## CONNECTOR SPECIFICATIONS

Item		Specification
Operating voltage & current		30 Vdc, 3A
Insulation resistance		100 M $\Omega$ min. (with 500 Vdc megger)
Dielectric strength		1,500 Vac for 1 min (across pins, and between pins and coupling)
Initial contact resistance		40 m $\Omega$ max. (excluding intrinsic resistance of cable conductor, at 3A with male-female combination)
Mating/unmating force		0.4–4.0 N (per pin)
Mating cycles		At least 50
Cable pullout strength		100 N min.
Vibration resistance		10–55 Hz, 1.5 mm peak-to-peak amplitude, 2 h each in X, Y, and Z directions (NECA C 4508)
Shock resistance		980 m/s <sup>2</sup> , 10 times each in X, Y, and Z directions
Protective structure		IP67
Operating temperature		-15 to +70 °C
Operating humidity		95 % RH max.
Material	Pins	Pins and sockets: copper alloy (gold plated)
	Pin holder	Polybutylene terephthalate resin, UL94 V-0, gray
	Housing	Polyester elastomer, UL94 V-0, gray
	Male ring	Zinc alloy (nickel plated)
	Female ring	Zinc alloy (nickel plated)
	O-ring	Fluororubber

## CABLE SPECIFICATIONS

Item	Specification
External diameter	6.0 mm
Cable type	Oil-resistant and vibration-resistant vinyl insulated cable
Core cross-sectional area	0.5 mm <sup>2</sup> (110/0.08)
Cores	4
Sheath color	Gray

## EXTERNAL DIMENSIONS

(unit: mm)

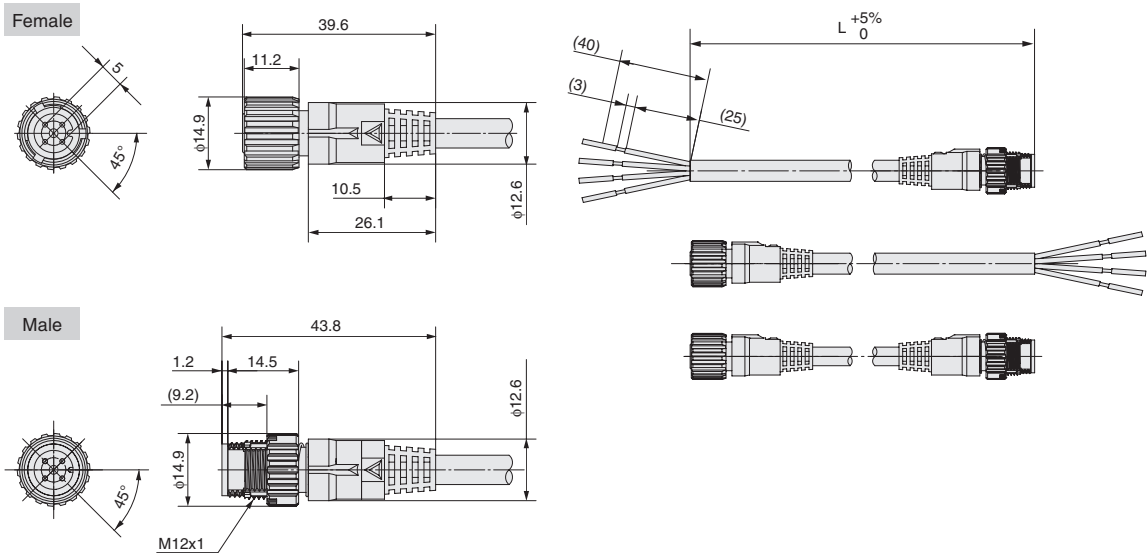

## PINOUT AND INSULATION COLOR

● Model No. / pin Nos. /shape

Insulation color ① ▶ Brown ② ▶ White ③ ▶ Blue ④ ▶ Black

PA7-4IBX□□SK

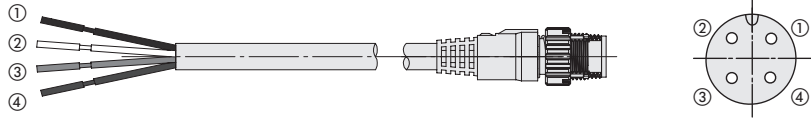

PA7-4ISX□□SK

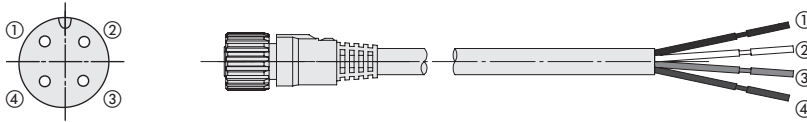

PA7-4ISB□□SK

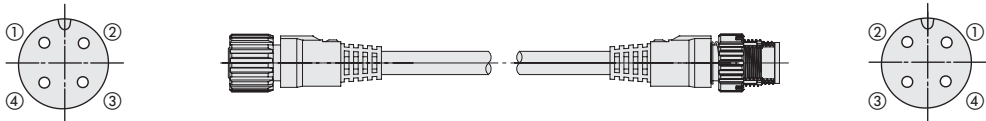

Photoelectric switch model		Pin No.
HP7-T□-S003	Emitter	①+ ③-
	Receiver	
HP7-P□-S003	Retroreflective	①+ ④Out ③-
HP7-A□-S003	Diffuse scan	

Proximity switch type		Pin No.
FL7M-□J6HD-SN03	With polarity, NO	①+ ④-
FL7M-□K6H-SN03	With polarity, NC	①+ ②-
FL7M-□W6-SN03	No polarity, NO	③ ④
FL7M-□Y6-SN03	No polarity, NC	① ②

Limit switch type		Pin No.
1LS1-JEC-SD03	Standard	①NC ②NC ③NO ④NO
1LS71-JWC-SD03	Spatter-resistant	
1LS-J720EC-SD03	Long-life	

## CONNECTOR PART NAMES

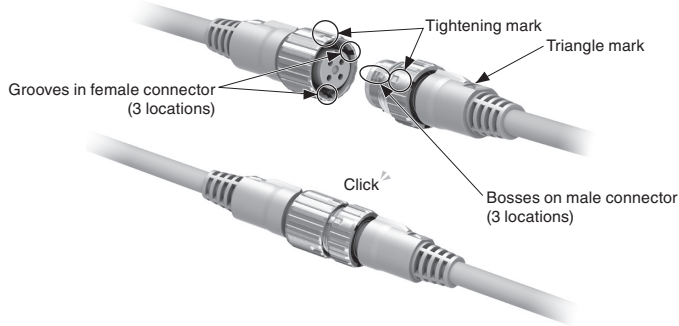

## CONNECTOR CONNECTION PROCEDURE

### Tightening after quick-lock connection (male and female connectors)



- Align the triangle marks, push the connectors together all the way, and then tighten.

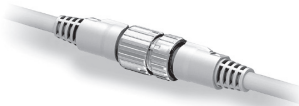

- Holding the coupling rings on the male and female connectors, insert the bosses on the male connector into the grooves in the female connector.



- Rotate the coupling rings on the male and female connector by 45°.
- When you feel or hear a click the connectors are connected. You can verify that connectors are connected by looking at the alignment of the tightening marks.

### Tightening threaded rings and quick-lock coupling rings

- If the threads on the mating connector are made of resin, misalignment when first tightening may damage the threads. Before tightening, fit the threaded ring into place by inserting it all the way, keeping the axes of the shafts aligned.
- Tighten the coupling as tight as you can by hand (0.4 to 0.6 N·m). Use of a tool such as pliers will damage the coupling.
- Insufficient tightening may not satisfy the IP67 requirement or may lead to a loose connection.

## PRECAUTIONS FOR HANDLING

### 1 Connecting and disconnecting connectors

- Before connecting or disconnecting connectors, be sure to turn the power OFF.
- To disconnect connectors, do not pull the cable. Hold the coupling rings.

### 2 Cap

- The cap attached to this product during delivery is to keep foreign matter out during transport. It is not for waterproofing.
- When connecting this product, remove the cap.

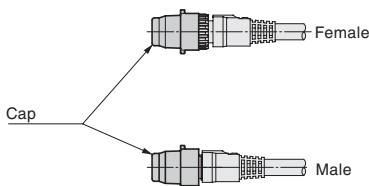

### 3 Other

- This is an integrally molded resin product. After connection, the connector should not be used while there is an external force continuously applied to it. Also, do not use the connector as a platform, place a heavy object on it, or hang objects from it.
- An IP67 protective structure is not intended for underwater use. Do not use the connector when it is submerged in water.
- If this connector is used in an environment where it gets wet, the coupling ring will corrode.