

# Compact Cylindrical Proximity Switches with Built-in Amplifier





**FL7(N/M) Series**

The smallest amplifier in the industry, built into DC2-wire cylindrical switches



- Compact cylindrical switch head  
Unthreaded type (**FL7N**): 4 dia. mm x 30 mm  
Threaded type (**FL7M**): M5 mm x 30 mm
- Sealed to IP67

## ORDER GUIDE

Switch head shape	Sensing distance	Catalog listing	Output type	Operation mode
Unthreaded 4 dia. mm 	 0.8 mm	<b>FL7N-P8J6</b>	DC2-wire	N.O.
		<b>FL7N-P8K6</b>		N.C.
Threaded M5 mm 	 0.8 mm	<b>FL7M-P8J6</b>		N.O.
		<b>FL7M-P8K6</b>		N.C.

## SPECIFICATIONS

Switch head type	Unthreaded type		Threaded type	
	FL7N-P8J6	FL7N-P8K6	FL7M-P8J6	FL7M-P8K6
Catalog listing				
Actuation method	High-frequency oscillation			
Rated supply voltage	12/24 Vdc			
Operating voltage range	10 to 30 Vdc			
Leakage current	0.6 mA max. (24 Vdc)			
Rated sensing distance	0.8 mm			
Standard target object	5 x 5 x 1 mm (SPCC)			
Differential travel	15 % max. of sensing distance			
Operating mode	N.O. (normally open)	N.C. (normally closed)	N.O. (normally open)	N.C. (normally closed)
Output operational mode	DC2-wire, transistor output			
Control output	Switching current 3 to 100 mA, voltage drop 3.0V max. (with 50 mA switching current and 2 m cable), output dielectric strength 30 Vdc			
Operating frequency	900 Hz min.			
Temperature drift	±15 % max. of sensing distance (at 25°C) in the -25 to +70°C range			
Operation indication	Orange LED lights up when in sensing area			
Operating temperature	-25 to +70 °C			
Insulation resistance	50 MΩ min. (by 500 Vdc megger)			
Dielectric strength	1,000 Vac, 50/60 Hz for 1 min between all live parts and case			
Vibration resistance	10 to 55 Hz, 1.5 mm peak-to-peak amplitude, 2 h each in X, Y and Z directions			
Shock resistance	500 m/s <sup>2</sup> 10 times each in X, Y and Z directions			
Protective structure	IP67 (IEC standard)			
Max. tightening torque	0.2 N·m max. 6 to 30 mm from the sensing face (assumes use of rubber spacer [included])		0.98 N·m max.	
Weight	Approx. 28 g (including 2 m cable)			
Circuit protection	Surge absorption, load short-circuit protection, reverse connection protection circuit			

## SENSING AREA (typical)

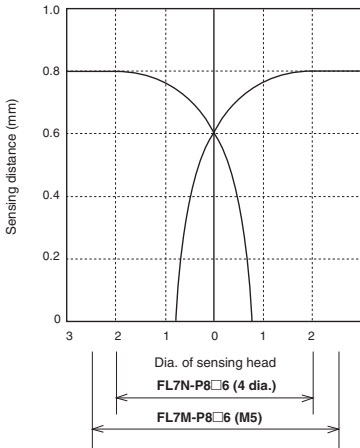

## SENSING DISTANCE ACCORDING TO MATERIAL AND SIZE OF OBJECT (typical)

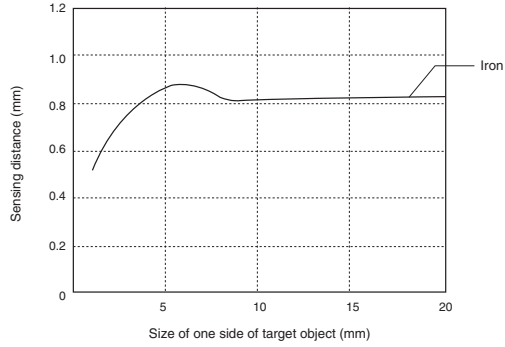

## EXTERNAL DIMENSIONS

(unit: mm)

### Unthreaded type: FL7N-P8□6

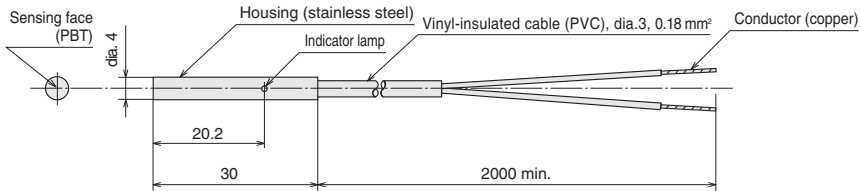

### Threaded type: FL7M-P8□6

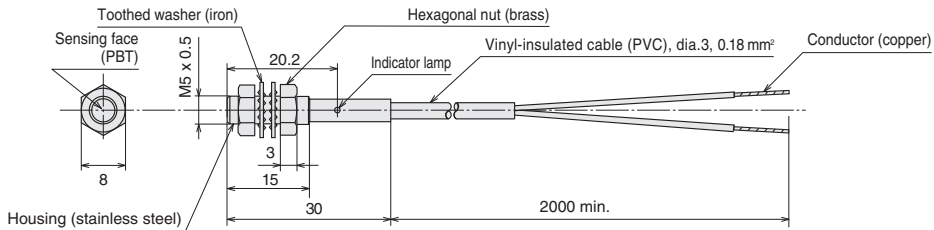

## WIRING DIAGRAMS

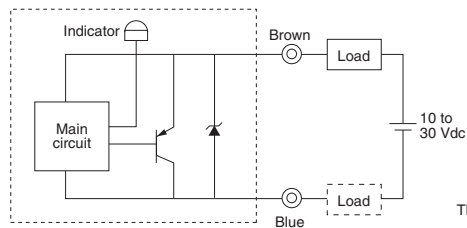

The load may be connected to either pole.

## PRECAUTIONS FOR USE

### 1. Mounting

The allowable tightening torque varies according to the distance from the sensing face

#### Unthreaded type

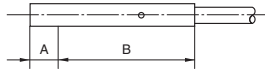

#### Threaded type

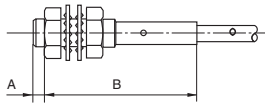

Catalog listing	Length A (mm)	Max. tightening torque (N·m)	
		A	B
FL7N-P8□6□	6	Do not tighten	0.2
FL7M-P8□6□	0	1	1

Note: The table shows max. tightening torque when toothed washers (provided) are used.

### 2. Influence of surrounding metal

Metal other than the target object surrounding the switch may influence operating characteristics. Leave space between the switch and surrounding metal as shown below.

Shaded areas indicate surrounding metal other than the target object.

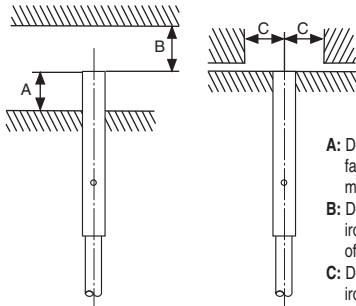

- A:** Distance from sensing face of proximity switch to mounting surface
- B:** Distance from surface of iron plate to sensing face of proximity switch.
- C:** Distance from surface of iron plate to center of proximity switch when A=0

A (mm)	B (mm)	C (mm)
0	2.4	4

### 3. Mutual interference prevention

When mounting proximity switches either parallel to or facing each other, mutual interference may cause the switch to malfunction. Maintain at least the distances indicated in the figures below.

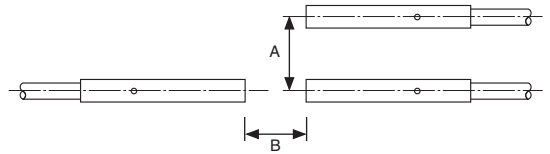

A (mm)	B (mm)
15	20

### 4. Minimum cable bend radius (R)

The minimum bend radius (R) of the cable is 3 times the cable diameter. Take care not to bend the cable beyond this radius. Also, do not excessively bend the cable within 30 mm of the cable lead-in port.

Before use, thoroughly read the "Precautions for use" and "Precautions for handling" in the Technical Guide on pages C-107 to C-113 as well as the instruction manual and product specification for this switch.