



**HEATING**  
SYSTEMS

# Cata-Dyne™

Explosion-Proof Gas Catalytic Heaters



**Explosion-Proof Gas Catalytic Heaters**

# Contents

<b>Cata-Dyne™ Explosion-Proof Gas Catalytic Heaters.....</b>	<b>4</b>	<b>CHS Series Cata-Dyne™ Heating Package .....</b>	<b>30</b>
Infrared Technology .....	4	Control Panel Features .....	30
How Our Cata-Dyne™ Operates .....	5	Control Panel Benefits .....	30
How the Catalyst Works .....	5	Heater Features.....	30
WX Series Explosion-Proof Gas Catalytic Heaters.....	7	Heater Benefits.....	30
MKII Series Explosion-Proof Gas Catalytic Heaters.....	8	<b>Accessories .....</b>	<b>32</b>
WXS Series Explosion-Proof Gas Catalytic Heaters.....	9	Safety Shut-Off Valves.....	32
BX Series Catalytic Heaters.....	10	ASV375 - Safety Shut-Off Valves .....	32
‘G’ Series Catalytic Pad - Non-Hazardous Areas.....	10	ASV375NT - Safety Shut-Off Valves.....	32
‘X’ Series Catalytic Pad - Hazardous Areas...	10	Mertik Combination Gas Controls/Valves .	32
<b>Regulator Enclosures.....</b>	<b>13</b>	Thermostatic Temperature Control Valve .....	33
<b>Pipe Preheater Enclosures .....</b>	<b>15</b>	Manual Shut-Off Ball Valve .....	33
<b>Rotary Meter Enclosures .....</b>	<b>16</b>	Thermocouples .....	33
<b>Motor Valve Enclosures .....</b>	<b>17</b>	Gas Pressure Regulators.....	34
<b>Orifice Fitting Meter Enclosures .....</b>	<b>18</b>	Appliance Regulators .....	34
<b>Super Conductors.....</b>	<b>19</b>	Service or Low Pressure Regulators.....	34
<b>Instrument Gas Preheaters .....</b>	<b>20</b>	High Pressure Regulators .....	34
Enclosure Request for Quote Form .....	21	Battery Cables/Electric Start Up Leads .....	35
<b>Sure Seal™ Pipeline Systems .....</b>	<b>22</b>	Battery Cable Cabinet .....	35
<b>FLO-DRI Series Compressed Gas Scrubbing Systems.....</b>	<b>23</b>	Fuel Gas Hose.....	35
<b>LH Series Natural Gas Line Heaters .....</b>	<b>25</b>	Strap-On Grilles.....	36
Hybrid Capabilities .....	25	Snap-On Grilles.....	36
<b>MLH Series Micro Line Heaters .....</b>	<b>28</b>	Gas Pressure Test Kit.....	36
Standard Micro Line Heater Sizes .....	29	POL Adapters.....	36
		Stratafan™ .....	37
		Vent Hood Assembly.....	37
		Wall Mounting Brackets.....	38
		45° Wall Mount Brackets.....	38
		Floor Stands.....	39
		<b>Conversion Data.....</b>	<b>40</b>
		<b>Inverse Square Law .....</b>	<b>40</b>

# Locations

As a leader in heating and filtration solutions, Thermon Heating Systems, Inc. is committed to ongoing research, product development and above all, excellence in customer service. With facilities across North America, Thermon Heating Systems manufactures five of the top brands in industrial heating in addition to a comprehensive line of engineered industrial filtration products including:

**Cata-Dyne™**

Explosion-Proof Gas Catalytic Heaters

**Ruffneck™**

Heaters for the Harshesht Environments

**Caloritech™**

Engineered Electric Heat

**3L Filters™**

Engineered Filtration Systems

**Norseman™**

Electric Explosion-Proof Heaters

**Fastrax™**

Track and Switch Heaters

Cata-Dyne™ gas catalytic explosion-proof heaters are available in various models with Btu ratings ranging from 1,000 to 48,000 Btu/hr (0.3 kW to 14.0 kW). In addition, these heaters can be banked together to obtain any Btu (kW) rating desired. Thermon Heating Systems' Cata-Dyne™ heaters are competitively priced, simple to install and operate, and require minimal maintenance under normal operating conditions. These heaters are economical to operate and highly efficient.

We invite you to visit [www.thermon.com](http://www.thermon.com) to view the broad range of innovative industrial heating products manufactured by Thermon Heating Systems, Inc.



# Cata-Dyne™ Explosion-Proof Gas Catalytic Heaters

## The Industry Standard

Cata-Dyne™ heaters boast the most efficient conversion of hydrocarbon fuels to infrared energy compared to any competitive brand on the market today, with over a quarter of a million units in service during our 40-year history and an exceptional safety record.

Designed for both hazardous and non-hazardous applications, Cata-Dyne™ is the benchmark in innovation for space or spot heating.

## Customer Care

Thermon Heating Systems, Inc.'s state of the art, 105,000 square feet, Edmonton manufacturing facility is designed to ensure our worldwide customer base of the most efficient explosion-proof and general purpose infrared gas catalytic heaters and heating systems for use in industrial heating. We are the only fully integrated infrared gas catalytic manufacturing plant in the world, sharing our unique technology and manufacturing techniques with three other manufacturing facilities. This enables us to exert greater quality control over our product lines and allows us to respond quickly to our customer's special heating application needs.

Thermon Heating Systems, Inc. has set the industry standard for total quality customer service by offering same or next day product delivery. We also refurbish "well used" heaters into "like new" condition in our repair service center.

Every heater manufactured or repaired by Thermon Heating Systems, Inc. undergoes stringent safety and performance testing in accordance with all applicable Safety Certification standards including CSA and FM. Our ongoing commitment to the safety and well being of our customers includes free product safety instruction sessions by our field sales professionals covering everything from an overview of basic infrared technology to detailed explanations on how our unique Cata-Dyne™ catalytic technology works.

## Infrared Technology

- Infrared is smart. it heats only what needs to be heated: personnel or equipment within a facility, not the surrounding air
- Infrared is direct. it takes less time and energy to do the job
- Infrared is versatile. it handles a large variety of process and space heating applications
- Infrared is environmentally friendly. it helps surpass today's ever-tightening standards

Infrared radiation is a form of electromagnetic energy that is generated by the vibration and rotation of atoms and molecules within all objects with temperatures above absolute zero (0°Kelvin; -273°C; or -459°F).

Electromagnetic energy, which travels at the speed of light, is comprised of waves that can be measured both electrically and magnetically.

Infrared (literally meaning below or beyond the red) is located between the visible and microwave portions of the electromagnetic spectrum and shares many of the same properties of visible light, except it has a longer wavelength. When infrared waves encounter a solid object they can be reflected (bounced off), diffracted (scattered), refracted (bent), transmitted (pass through), or absorbed by the object. Several of these effects can take place at the same time.



## How Our Cata-Dyne™ Operates

- Power is applied to the electrical elements which provide the required 120°C (250°F) preheat temperature for the catalyst pad
- Fuel enters the rear of the heater through an orifice and a gas distribution system
- The baffle plate prevents the insulation from choking off the fuel entry points
- The first layer of insulation allows the fuel to build up enough pressure to provide even gas distribution throughout the heater
- The fuel passes through the heater insulation and comes in contact with the under side of the catalyst
- With the catalyst pad at the preheat temperature, the fuel is converted into infrared energy

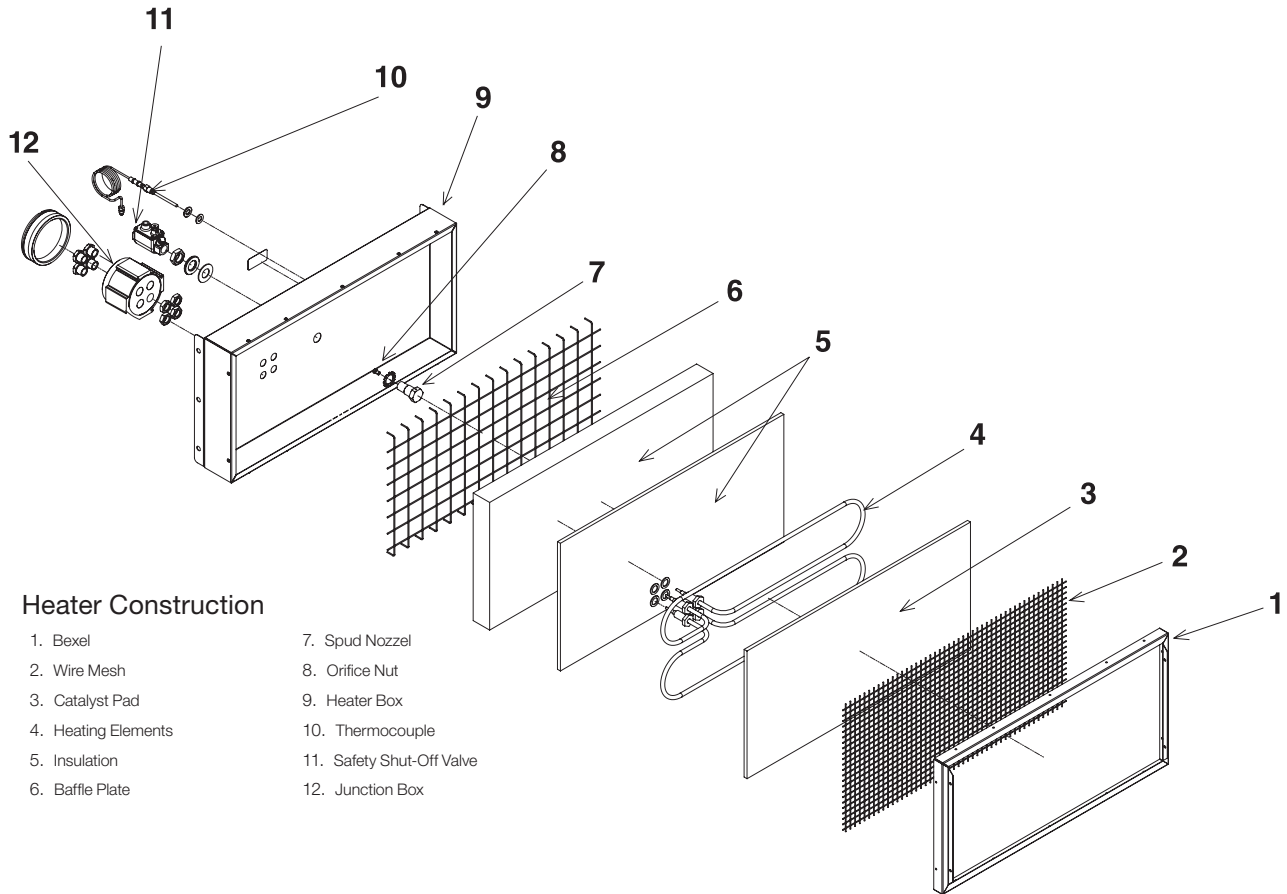

Figure 1

## How the Catalyst Works

- Once the catalyst pad has reached the activation temperature of 120°C (250°F) the pad is ready to emit infrared energy
- Natural gas or propane and atmospheric oxygen chemically react with the proprietary catalyst in the pad
- The reaction creates infrared energy with water and carbon dioxide as by-products
- The fuel should be clean dry gas; contaminants such as hydrogen sulphide, oil and moisture will affect the longevity of the pad



# Model Coding

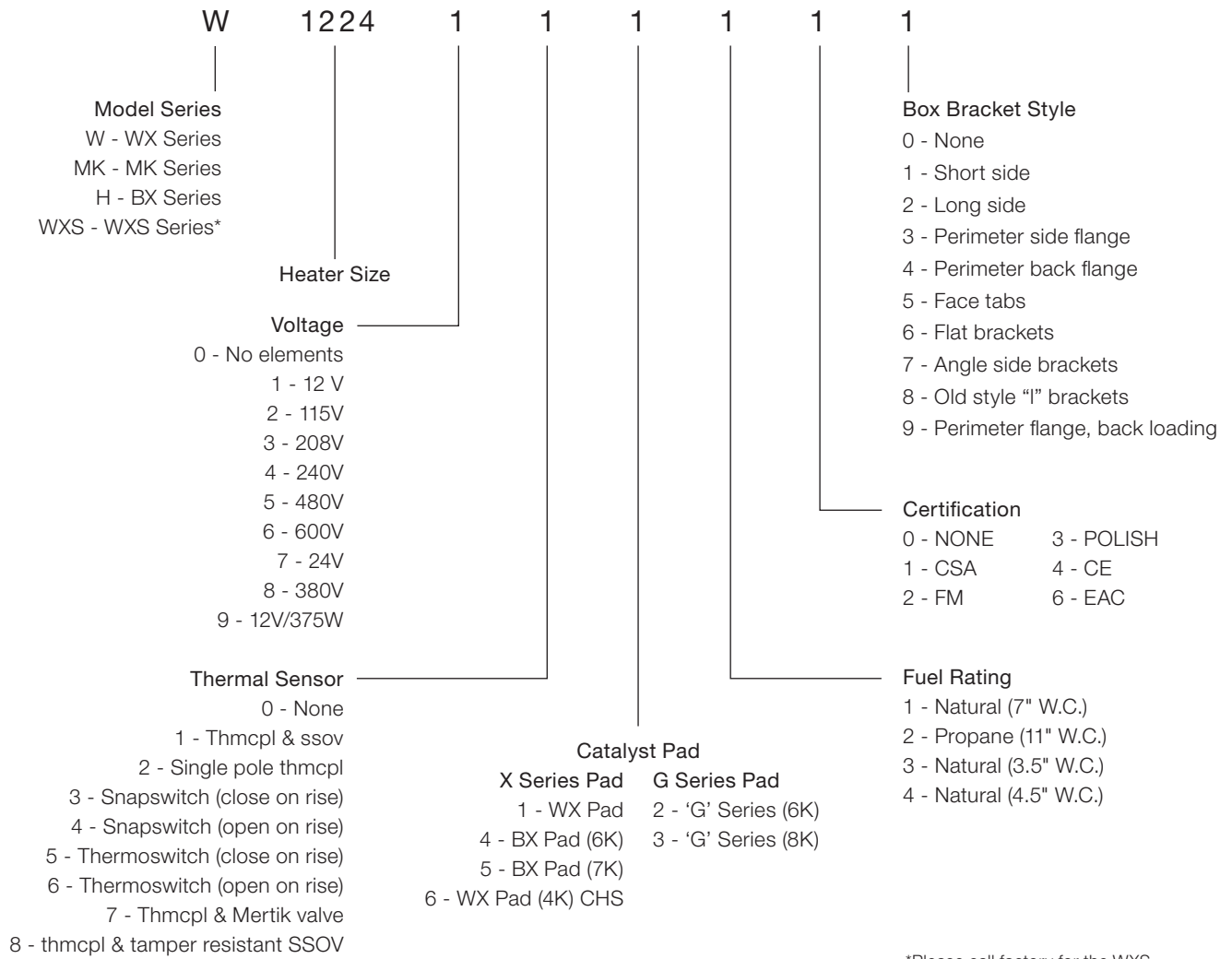

\*Please call factory for the WXS.

# WX Series Explosion-Proof Gas Catalytic Heaters

The Cata-Dyne™ WX Series infrared gas catalytic explosion-proof heaters are the industry standard for hazardous location heating needs. They are available in over twenty, three-inch depth cabinet sizes, with gas, electrical and accessory connections on the back side of the heater. These are the heaters of choice for many of our customers who have come to trust their reliability.

## Applications

WX Series heaters are used in many different applications that involve spot or space heating where hazardous materials may be present.

These include:

- Comfort heating for industrial buildings and installations
- Freeze protection for equipment or components
- Drying or curing processes

## Features

- Heater box constructed of 300 series stainless steel for corrosion protection
- Cata-Dyne™ proprietary explosion-proof catalyst pad.
- Standard 3/8" NPT gas connections
- Explosion-proof electrical junction box with standard 3/4" NPT connections
- Cata-Dyne™ heaters are designed to operate on either natural gas or propane
- Cata-Dyne™ heaters do not require electrical power to operate once they have been started
- Our explosion-proof catalytic technology is the most efficient in the industrial heating market
- Heater contains no moving parts and is designed to operate indefinitely when supplied with air and clean fuel
- Internal heater components such as our proprietary catalyst pad and preheat Caloritech™ tubular element are manufactured in-house

## Certifications

The WX Series Cata-Dyne™ explosion-proof catalytic heaters are approved for the following:

- Canadian Standards Association (CSA) for use in Class I, Division 1 & 2, Group D hazardous locations
- Factory Mutual (FM) for use in Class I, Division 1, Group D hazardous locations. Temperature code T2C at an ambient temperature of 40°C (104°F)

See Table 1, page 11 for fuel & electrical ratings.



# MKII Series Explosion-Proof Gas Catalytic Heaters

Our Cata-Dyne™ MKII Series explosion-proof catalytic heater has sleek side mount controls ideal for customers seeking to reduce costs with easier and quicker heater installation.

## Applications

The Cata-Dyne™ MKII Series heaters are used in many different applications that involve spot or space heating where hazardous materials may be present.

These include:

- Comfort heating for industrial buildings and installations
- Freeze protection for equipment or components
- Drying or curing processes

## Features

- Heater box constructed of 300 series stainless steel for corrosion protection
- Cata-Dyne™ proprietary explosion-proof catalyst pad.
- Standard 3/8" NPT gas connections
- Cata-Dyne™ heaters are designed to operate on either natural gas or propane
- Cata-Dyne™ heaters do not require electrical power to operate once they have been started
- Our QuikSTART heater technology reaches the catalytic threshold faster, bringing the heater to full operating temperature in half the time
- Shorter thermocouple is nickel plated with an added polymer sleeve to enhance the corrosion protection for a stronger electromagnetic connection to the safety shut-off valve (SSOV)
- All gas control components as well as all electrical connections are side mounted for easy installation and access
- Side mounted rating plate for easy visibility
- Single start up element with the same power and wattage rating as used in the standard WX heaters dual elements
- Heater contains no moving parts and is designed to operate indefinitely when supplied with air and clean fuel
- Internal heater components such as our proprietary catalyst pad and preheat Caloritech™ tubular element are manufactured in-house

## Certifications

The Cata-Dyne™ MKII Series explosion-proof catalytic heater is approved for the following:

- Canadian Standards Association (CSA) for use in Class I, Division 1 & 2, Group D hazardous locations
- Factory Mutual (FM) for use in Class I, Division 1, Group D hazardous locations. Temperature code T2C at an ambient temperature of 40°C (104°F)

See Table 3, page 11 for fuel & electrical ratings

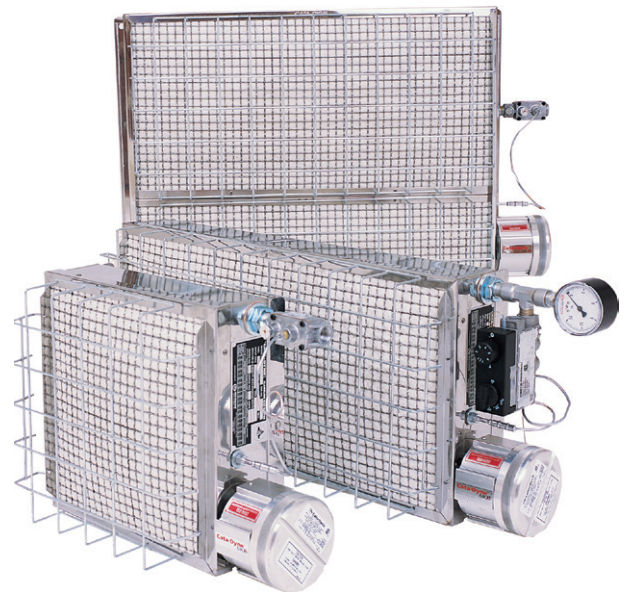



# WXS Series Explosion-Proof Gas Catalytic Heaters

## Thinner Space Saving Unit

The Cata-Dyne™ WXS Series “Slim Line” explosion-proof catalytic heater is everything our WX Series heater has become renowned for with the added feature of a more compact 1 ½” (38 mm) thick stainless steel cabinet. This design versatility allows it to be used in both traditional installations and in compact enclosures for valves, regulators and instrumentation.

## Applications

Slim Line heaters are used in many different applications that involve spot or space heating where hazardous materials may be present.

These include:

- Comfort heating for industrial buildings and installations
- Freeze protection for equipment or components

## Features

- Now available in new 8" and 12" round heater sizes
- These units are designed to run on either clean natural gas or propane
- All standard Cata-Dyne™ accessories can be used with the Slim Line models
- 1 ½” (38 mm) thinner than the standard Cata-Dyne™ heater
- Equipped with universal mounting brackets, the heater can easily be mounted into existing facilities or enclosures
- Heater boxes are constructed of 300 series stainless steel for maximum corrosion protection
- Units are fitted with standard 3/8" NPT gas connections.
- No power is needed to operate the heaters or their controls once the heater has started and the catalytic reaction has been established
- Our QuikSTART heater technology reaches the catalytic threshold faster bringing the heater to full operating temperature in half the time
- Our explosion-proof catalytic technology is the most efficient in the industrial heating market
- Heater contains no moving parts and is designed to operate indefinitely when supplied with air and clean fuel
- Internal heater components such as our proprietary catalyst pad and preheat Caloritech™ tubular element are manufactured in-house

## Certifications

- FM, Class I, Division 1, Group D explosion-proof ratings

See Table 5, page 12 for fuel & electrical ratings.



# BX Series Catalytic Heaters

## 'G' Series Catalytic Pad - Non-Hazardous Areas

The Cata-Dyne™ BX Series infrared gas catalytic heater with 'G' Series catalytic pad is designed for use in non-hazardous heating applications such as infrared drying and curing ovens. It is fitted with a patented high temperature catalyst pad, operates on either natural or propane fuel and is available in a wide variety of cabinet sizes.

### Applications

The large surface area of the Cata-Dyne™ heater allows for efficient transfer of infrared heat that can be used in a variety of applications including:

- Facility space heating
- Process heating
- Freeze protection
- Comfort heating for personnel
- Ovens

### Features

- Internal heater components such as our proprietary catalyst pad and preheat Caloritech™ tubular element are manufactured in-house
- Multiple Btu input ratings and a variety of standard heater sizes available
- Offered in a variety of preheat voltages
- Natural gas (NG) or propane (LPG) configurations
- Choice of manual control or electronic control options
- Multiple heater mounting bracket configurations available
- Heater contains no moving parts and is designed to operate indefinitely when supplied with air and clean fuel

### Certifications

- G Series catalytic pad is certified by Canadian Standards Association (CSA) and Factory Mutual (FM) and (European standards) for non-hazardous area applications.

See Table 4, page 12 for fuel & electrical ratings.



## 'X' Series Catalytic Pad - Hazardous Areas

(Only sold in the USA)

BX Series heaters are used in many different applications that involve spot or space heating where hazardous materials may be present.

### Applications

- Comfort heating for industrial buildings and installations
- Freeze protection for equipment or components
- Drying or curing processes

### Features

- Heater box constructed of 300 series stainless steel for corrosion protection
- Standard 3/8" NPT gas connections
- Explosion-proof electrical junction box with standard 3/4" NPT connections
- Cata-Dyne™ heaters are designed to operate on either natural gas or propane
- Cata-Dyne™ heaters do not require electrical power to operate once they have been started
- Our explosion-proof catalytic technology is the most efficient in the industrial heating market
- Heater contains no moving parts and is designed to operate indefinitely when supplied with air and clean fuel
- Internal heater components such as our proprietary catalyst pad and preheat Caloritech™ tubular element are manufactured in-house

### Certifications

- X Series catalytic pad is the industry standard for hazardous location heating needs.
- Factory Mutual (FM) for use in Class I, Division 1, Group D hazardous locations. Temperature code T2C at an ambient temperature of 40°C (104°F). This style heater is only sold in the USA.

See Table 2, page 11 for fuel & electrical ratings.



Table 1 – WX Series Fuel and Electrical Rating Data (CSA and FM)

Model No.	Max. Gas Input		Min. Gas Input				Max. Gas Flow				Start-Up Amperage						
	Natural Gas / Propane		Natural Gas		Propane		CFH		m <sup>3</sup> /hr		12V	120V	208V	240V	380V	480V	600V
	Btu/hr	kW	Btu/hr	kW	Btu/hr	kW	Natural Gas	Propane	Natural Gas	Propane							
W6x6	1,250	0.366	500	0.147	375	0.110	1.25	0.5	0.0354	0.0142	7.1	0.7	-	0.4	-	-	-
W6x12	2,500	0.733	1,000	0.293	750	0.220	2.5	1.0	0.0708	0.0283	7.1	0.7	-	0.4	-	-	-
W6x24	5,000	1.465	2,000	0.586	1,500	0.440	5.0	2.0	0.1416	0.0566	15.0	2.1	1.2	1.0	-	-	-
W6x60	12,500	3.663	5,000	1.465	3,750	1.099	12.5	5.0	0.3540	0.1416	-	-	-	-	-	1.3	-
W8x8	2,222	0.651	900	0.264	700	0.205	2.2	0.9	0.0629	0.0252	7.1	0.7	-	0.4	-	-	-
W10x12	4,167	1.221	1,700	0.498	1,250	0.366	4.2	1.7	0.1180	0.0472	15.0	2.1	1.2	1.0	-	-	-
W12x12	5,000	1.465	2,000	0.586	1,500	0.440	5.0	2.0	0.1416	0.0566	15.0	2.1	1.2	1.0	-	-	-
W12X24	10,000	2.931	4,000	1.172	3,000	0.879	10.0	4.0	0.2832	0.1133	30.0	4.2	2.4	2.1	-	1.5	0.9
W12x36	15,000	4.396	6,000	1.758	4,500	1.319	15.0	6.0	0.4248	0.1699	30.0	5.0	2.9	2.5	1.6	1.3	1.0
W12x48	20,000	5.861	8,000	2.345	6,000	1.758	20.0	8.0	0.5663	0.2265	30.0	6.7	3.9	3.3	2.1	1.7	1.3
W12x60	25,000	7.327	10,000	2.931	7,500	2.198	25.0	10.0	0.7079	0.2832	45.0	10.4	6.0	5.2	3.3	2.6	2.1
W12x72	30,000	8.792	12,000	3.517	9,000	2.638	30.0	12.0	0.8495	0.3398	-	12.1	7.0	6.0	3.8	3.0	2.4
W18x24	15,000	4.396	6,000	1.758	4,500	1.319	15.0	6.0	0.4248	0.1699	30.0	4.2	2.4	2.1	-	1.5	-
W18x30	18,750	5.495	7,500	2.198	5,625	1.649	18.75	7.5	0.5309	0.2124	-	-	-	-	-	1.5	-
W18x36	22,500	6.594	9,000	2.638	6,750	1.978	22.5	9.0	0.6371	0.2549	-	10.0	5.8	5.0	3.2	2.5	2.0
W18x48	30,000	8.792	12,000	3.517	9,000	2.638	30.0	12.0	0.8495	0.3398	-	13.3	7.7	6.7	4.2	3.3	2.7
W18x60	37,500	10.990	15,000	4.396	11,250	3.297	37.5	15.0	1.0619	0.4248	-	20.8	12.0	10.4	6.6	5.2	4.2
W18x72	45,000	13.188	18,000	5.275	13,500	3.956	45.0	18.0	1.2743	0.5097	-	24.2	14.0	12.1	7.6	6.0	4.8
W24x24	20,000	5.861	8,000	2.345	6,000	1.758	20.0	8.0	0.5663	0.2265	30.0	4.2	2.4	2.1	-	1.5	-
W24x30	25,000	7.327	10,000	2.931	7,500	2.198	25.0	10.0	0.7079	0.2832	30.0	4.2	2.4	2.1	-	1.5	-
W24x36	30,000	8.792	12,000	3.517	9,000	2.638	30.0	12.0	0.8495	0.3398	-	10.0	5.8	5.0	3.2	2.5	2.0
W24x48	40,000	11.723	16,000	4.689	12,000	3.517	40.0	16.0	1.1327	0.4531	-	13.3	7.7	6.7	4.2	3.3	2.7
W24x60	50,000	14.654	20,000	5.861	15,000	4.396	50.0	20.0	1.4159	0.5663	-	20.8	12.0	10.4	6.6	5.2	4.2
W24x72	60,000	17.584	24,000	7.034	18,000	5.275	60.0	24.0	1.6990	0.6796	-	24.2	14.0	12.1	7.6	6.0	4.8

Table 2 – BX Series Fuel and Electrical Rating Data (FM only) - Available only in the USA

Model No.	Max. Gas Input		Min. Gas Input				Max. Gas Flow				Start-Up Amperage						
	Natural Gas/ Propane		Natural Gas		Propane		CFH		m <sup>3</sup> /hr		12V	120V	208V	240V	380V	480V	600V
	Btu/hr	kW	Btu/hr	kW	Btu/hr	kW	Natural Gas	Propane	Natural Gas	Propane							
H6x6	1,500	0.44	500	0.147	375	0.11	1.5	0.6	0.0425	0.017	7.1	0.7	-	0.4	-	-	-
H6x12	3,000	0.879	1,000	0.293	750	0.22	3	1.2	0.085	0.034	7.1	0.7	-	0.4	-	-	-
H6x24	6,000	1.758	2,000	0.586	1,500	0.44	6	2.4	0.1699	0.068	15	2.1	1.2	1	-	-	-
H8x8	2,667	0.782	900	0.264	700	0.205	2.7	1.1	0.0755	0.0302	7.1	0.7	-	0.4	-	-	-
H10x12	5,000	1.465	1,700	0.498	1,250	0.366	5	2	0.1416	0.0566	15	2.1	1.2	1	-	-	-
H12x12	6,000	1.758	2,000	0.586	1,500	0.44	6	2.4	0.1699	0.068	15	2.1	1.2	1	-	-	-
H12X24	12,000	3.517	4,000	1.172	3,000	0.879	12	4.8	0.3398	0.1359	30	4.2	2.4	2.1	-	1.5	0.9
H12x36	18,000	5.275	6,000	1.758	4,500	1.319	18	7.2	0.5097	0.2039	-	5	2.9	2.5	1.6	1.3	1
H12x48	24,000	7.034	8,000	2.345	6,000	1.758	24	9.6	0.6796	0.2718	30	6.7	3.9	3.3	2.1	1.7	1.3
H12x60	30,000	8.792	10,000	2.931	7,500	2.198	30	12	0.8495	0.3398	45	10.4	6	5.2	3.3	2.6	2.1
H12x72	36,000	10.551	12,000	3.517	9,000	2.638	36	14.4	1.0194	0.4078	-	12.1	7	6	3.8	3	2.4
H18x24	18,000	5.275	6,000	1.758	4,500	1.319	18	7.2	0.5097	0.2039	30	4.2	2.4	2.1	-	1.5	-
H18x30	22,500	6.594	7,500	2.198	5,625	1.649	22.5	9	0.6371	0.2549	-	-	-	-	-	1.5	-
H18x36	27,000	7.913	9,000	2.638	6,750	1.978	27	10.8	0.7646	0.3058	-	10	5.8	5	3.2	2.5	2
H18x48	36,000	10.551	12,000	3.517	9,000	2.638	36	14.4	1.0194	0.4078	-	13.3	7.7	6.7	4.2	3.3	2.7
H18x60	45,000	13.188	15,000	4.396	11,250	3.297	45	18	1.2743	0.5097	-	20.8	12	10.4	6.6	5.2	4.2
H18x72	54,000	15.826	18,000	5.275	13,500	3.956	54	21.6	1.5291	0.6116	-	24.2	14	12.1	7.6	6	4.8
H24x24	24,000	7.034	8,000	2.345	6,000	1.758	24	9.6	0.6796	0.2718	30	4.2	2.4	2.1	-	1.5	-
H24x30	30,000	8.792	10,000	2.931	7,500	2.198	30	12	0.8495	0.3398	30	4.2	2.4	2.1	-	1.5	-
H24x36	36,000	10.551	12,000	3.517	9,000	2.638	36	14.4	1.0194	0.4078	-	10	5.8	5	3.2	2.5	2
H24x48	48,000	14.067	16,000	4.689	12,000	3.517	48	19.2	1.3592	0.5437	-	13.3	7.7	6.7	4.2	3.3	2.7
H24x60	60,000	17.584	20,000	5.861	15,000	4.396	60	24	1.699	0.6796	-	20.8	12	10.4	6.6	5.2	4.2
H24x72	72,000	21.101	24,000	7.034	18,000	5.275	72	28.8	2.0388	0.8155	-	24.2	14	12.1	7.6	6	4.8

Table 3 – MKII Series (CSA and FM)

Model No.	Max. Gas Input		Min. Gas Input				Max. Gas Flow				Start-Up Amperage	
	Natural Gas / Propane		Natural Gas		Propane		CFH		m³/hr		12V	120V
	Btu/hr	kW	Btu/hr	kW	Btu/hr	kW	Natural Gas	Propane	Natural Gas	Propane		
MK12x12	5,000	1.464	2,000	0.586	1,500	0.440	5.0	2.0	0.1416	0.0566	15.0	2.1
MK12x24	10,000	2.929	4,000	1.172	3,000	0.879	10.0	4.0	0.2832	0.1133	30.0	4.2
MK18x24	15,000	4.393	6,000	1.758	4,500	1.319	15.0	6.0	0.4248	0.1699	30.0	4.2
MK18x48	30,000	8.787	12,000	3.517	9,000	2.638	30.0	12.0	0.8495	0.3398	–	13.3
MK24x24	20,000	5.858	8,000	2.345	6,000	1.758	20.0	8.0	0.5663	0.2265	30.0	4.2
MK24x48	40,000	11.716	16,000	4.689	12,000	3.517	40.0	16.0	1.1327	0.4531	–	13.3

Table 4 – G Series Fuel and Electrical Rating Data (CSA and FM - Non-Hazardous)

Model No.	Max. Gas Input		Min. Gas Input				Max. Gas Flow				Start-Up Amperage						
	Natural Gas / Propane		Natural Gas		Propane		CFH		m³/hr		12V	120V	208V	240V	380V	480V	600V
	Btu/hr	kW	Btu/hr	kW	Btu/hr	kW	Natural Gas	Propane	Natural Gas	Propane							
H6x6	1,500	0.440	500	0.147	375	0.110	1.5	0.6	0.0425	0.0170	7.1	0.7	–	0.4	–	–	–
H6x12	3,000	0.879	1,000	0.293	750	0.220	3.0	1.2	0.0850	0.0340	7.1	0.7	–	0.4	–	–	–
H6x24	6,000	1.758	2,000	0.586	1,500	0.440	6.0	2.4	0.1699	0.0680	15.0	2.1	1.2	1.0	–	–	–
H8x8	2,667	0.782	900	0.264	700	0.205	2.7	1.1	0.0755	0.0302	7.1	0.7	–	0.4	–	–	–
H10x12	5,000	1.465	1,700	0.498	1,250	0.366	5.0	2.0	0.1416	0.0566	15.0	2.1	1.2	1.0	–	–	–
H12x12	6,000	1.758	2,000	0.586	1,500	0.440	6.0	2.4	0.1699	0.0680	15.0	2.1	1.2	1.0	–	–	–
H12X24	12,000	3.517	4,000	1.172	3,000	0.879	12.0	4.8	0.3398	0.1359	30.0	4.2	2.4	2.1	–	1.5	0.9
H12x36	18,000	5.275	6,000	1.758	4,500	1.319	18.0	7.2	0.5097	0.2039	–	5.0	2.9	2.5	1.6	1.3	1.0
H12x48	24,000	7.034	8,000	2.345	6,000	1.758	24.0	9.6	0.6796	0.2718	30.0	6.7	3.9	3.3	2.1	1.7	1.3
H12x60	30,000	8.792	10,000	2.931	7,500	2.198	30.0	12.0	0.8495	0.3398	45.0	10.4	6.0	5.2	3.3	2.6	2.1
H12x72	36,000	10.551	12,000	3.517	9,000	2.638	36.0	14.4	1.0194	0.4078	–	12.1	7.0	6.0	3.8	3.0	2.4
H18x24	18,000	5.275	6,000	1.758	4,500	1.319	18.0	7.2	0.5097	0.2039	30.0	4.2	2.4	2.1	–	1.5	–
H18x30	22,500	6.594	7,500	2.198	5,625	1.649	22.5	9.0	0.6371	0.2549	–	–	–	–	–	1.5	–
H18x36	27,000	7.913	9,000	2.638	6,750	1.978	27.0	10.8	0.7646	0.3058	–	10.0	5.8	5.0	3.2	2.5	2.0
H18x48	36,000	10.551	12,000	3.517	9,000	2.638	36.0	14.4	1.0194	0.4078	–	13.3	7.7	6.7	4.2	3.3	2.7
H18x60	45,000	13.188	15,000	4.396	11,250	3.297	45.0	18.0	1.2743	0.5097	–	20.8	12.0	10.4	6.6	5.2	4.2
H18x72	54,000	15.826	18,000	5.275	13,500	3.956	54.0	21.6	1.5291	0.6116	–	24.2	14.0	12.1	7.6	6.0	4.8
H24x24	24,000	7.034	8,000	2.345	6,000	1.758	24.0	9.6	0.6796	0.2718	30.0	4.2	2.4	2.1	–	1.5	–
H24x30	30,000	8.792	10,000	2.931	7,500	2.198	30.0	12.0	0.8495	0.3398	30.0	4.2	2.4	2.1	–	1.5	–
H24x36	36,000	10.551	12,000	3.517	9,000	2.638	36.0	14.4	1.0194	0.4078	–	10.0	5.8	5.0	3.2	2.5	2.0
H24x48	48,000	14.067	16,000	4.689	12,000	3.517	48.0	19.2	1.3592	0.5437	–	13.3	7.7	6.7	4.2	3.3	2.7
H24x60	60,000	17.584	20,000	5.861	15,000	4.396	60.0	24.0	1.6990	0.6796	–	20.8	12.0	10.4	6.6	5.2	4.2
H24x72	72,000	21.101	24,000	7.034	18,000	5.275	72.0	28.8	2.0388	0.8155	–	24.2	14.0	12.1	7.6	6.0	4.8

Table 5 – WXS Slim Line Series Fuel and Electrical Rating Data (FM Only)

Model No.	Max. Gas Input		Min. Gas Input				Max. Gas Flow				Start-Up Amperage			
	Natural Gas / Propane		Natural Gas		Propane		CFH		m³/hr		12V	120V	240V	
	Btu/hr	kW	Btu/hr	kW	Btu/hr	kW	Natural Gas	Propane	Natural Gas	Propane				
WXS6x6	1,750	0.513	583	0.171	438	0.128	1.8	0.7	0.0496	0.0198	7.1	0.7	0.4	
WXS6x12	3,500	1.025	1,167	0.342	875	0.256	3.5	1.4	0.0991	0.0396	7.1	0.7	0.4	
WXS6x24	7,000	2.050	2,333	0.684	1,750	0.513	7.0	2.8	0.1982	0.0793	15.0	2.1	1.0	
WXS8x8	3,111	0.911	1,037	0.304	778	0.228	3.1	1.2	0.0881	0.0352	7.1	0.7	0.4	
WXS10x12	5,833	1.709	1,944	0.570	1,458	0.427	5.8	2.3	0.1652	0.0661	15.0	2.1	1.0	
WXS12x12	7,000	2.050	2,333	0.684	1,750	0.513	7.0	2.8	0.1982	0.0793	15.0	2.1	1.0	
WXS12x24	14,000	4.101	4,667	1.368	3,500	1.026	14.0	5.6	0.3964	0.1586	30.0	4.2	2.0	
WXS12x36	21,000	6.151	7,000	2.051	5,250	1.539	21.0	8.4	0.5947	0.2379	30.0	5.0	2.5	
WXS12x48	28,000	8.201	9,333	2.735	7,000	2.051	28.0	11.2	0.7929	0.3172	30.0	6.7	3.3	
WXS24x24	28,000	8.201	9,333	2.735	7,000	2.051	28.0	11.2	0.7929	0.3172	30.0	4.2	2.0	
WXS24x36	42,000	12.302	14,000	4.103	10,500	3.077	42.0	16.8	1.1893	0.4757	–	10.0	5.0	
WXS24x48	56,000	16.402	18,667	5.471	14,000	4.103	56.0	22.4	1.5858	0.6343	–	13.3	6.7	
Round	8 in	2,500	0.732	825	0.242	625	0.183	2.5	1.0	0.0708	0.0283	7.1	0.7	–
	12 in	5,500	1.611	1,825	0.535	1,375	0.403	5.5	2.2	0.1557	0.0623	15.0	2.1	–

# Regulator Enclosures

The Regulator Enclosure is specifically designed to provide freeze protection for a wide variety of natural gas pipeline regulators. Enclosures are designed for specific regulators and generic applications.

## Features

- Enclosure comes fully assembled
- Stainless steel enclosures provide added longevity for the harshest environments
- Cata-Dyne™ heaters are CSA or FM certified, available in both natural gas or propane
- Optional thermostats and regulators are available
- Designed to clamp directly to the pipeline, spring clamps make installation easy
- Custom designed enclosure packages available upon request

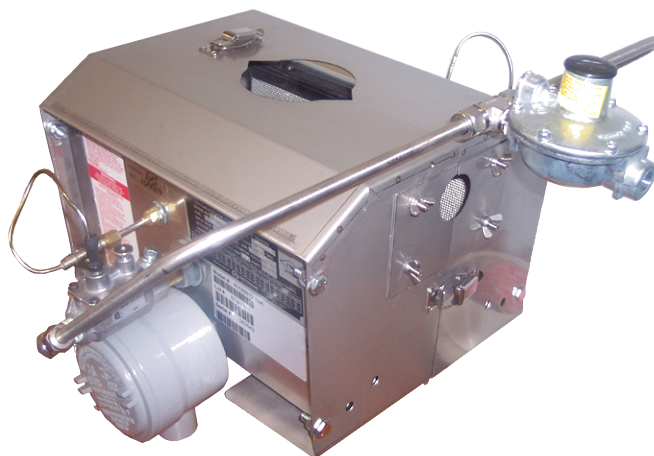

## Model Coding

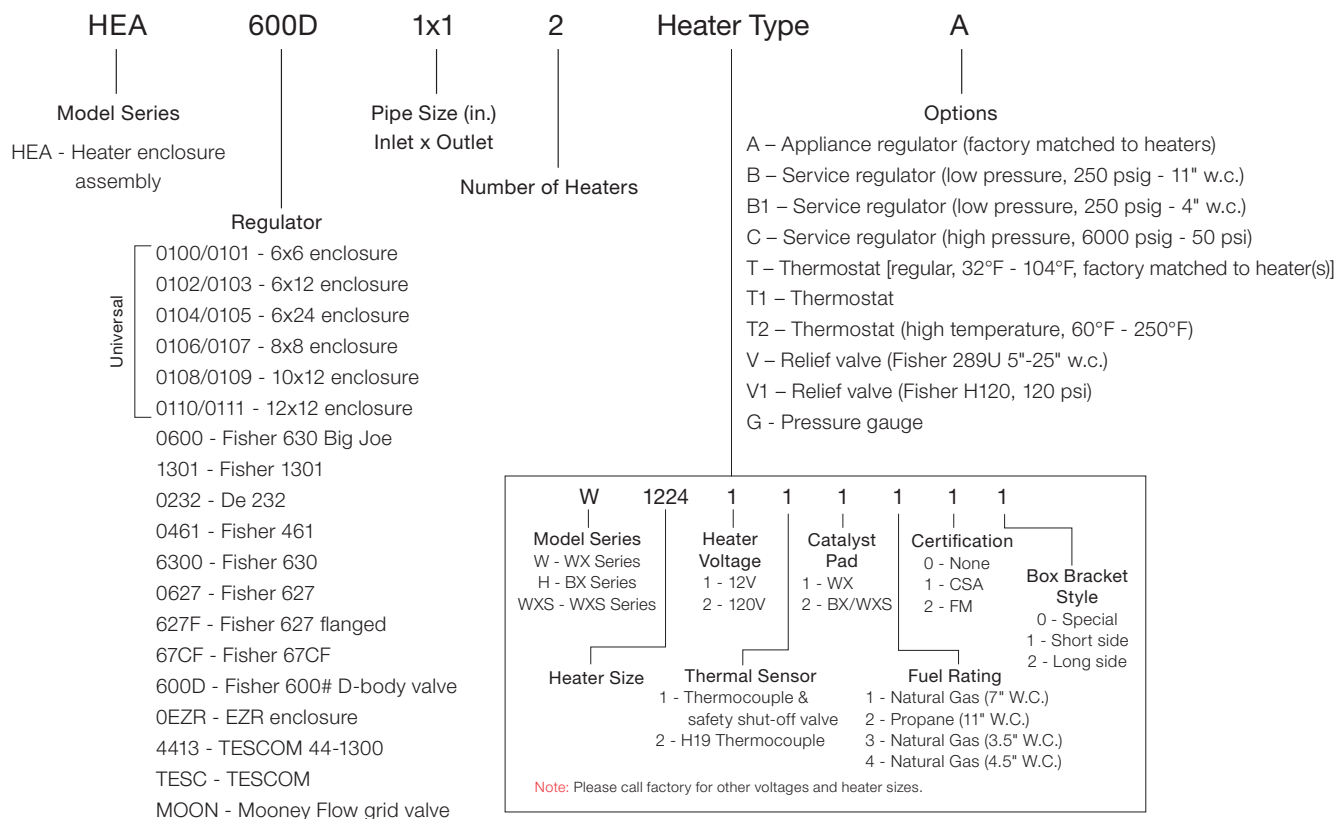
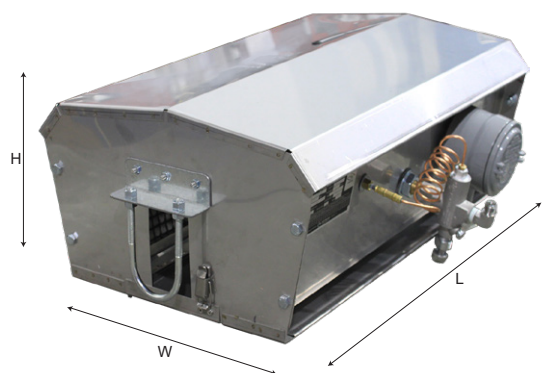

Table 6 – Regulator Enclosures

Model No.*	Description	Dimensions					
		L		W		H	
		in	mm	in	mm	in (mm)	mm
HEA0100-1X1-1-___0606	Enclosure, Universal 1 and 2" inlet pipe	10.125	257	8.375	213	8.563	218
HEA0101-1X1-2-___0606	Enclosure, Universal 1 and 2" inlet pipe	10.125	257	8.375	213	8.563	218
HEA0102-1X1-1-___0612	Enclosure, Universal 1 and 2" inlet pipe	12.250	311	11.000	279	8.250	210
HEA0103-1X1-2-___0612	Enclosure, Universal 1 and 2" inlet pipe	12.250	311	11.000	279	8.250	210
HEA0104-1X1-1-___0624	Enclosure, Universal 1 and 2" inlet pipe	24.500	622	11.000	279	8.250	210
HEA0105-1X1-1-___0624	Enclosure, Universal 1 and 2" inlet pipe	24.500	622	11.000	279	8.250	210
HEA0106-1X1-2-___0808	Enclosure, Universal 1 and 2" inlet pipe	12.125	308	14.125	359	10.188	259
HEA0107-1X1-2-___0808	Enclosure, Universal 1 and 2" inlet pipe	12.125	308	14.125	359	10.188	259
HEA0108-1X1-1-___1012	Enclosure, Universal 1 and 2" inlet pipe	14.000	356	16.000	406	14.000	356
HEA0109-1X1-2-___1012	Enclosure, Universal 1 and 2" inlet pipe	14.000	356	16.000	406	14.000	356
HEA0110-1X1-1-___1212	Enclosure, Universal 1 and 2" inlet pipe	14.000	356	16.000	406	14.000	356
HEA0111-1X1-2-___1212	Enclosure, Universal 1 and 2" inlet pipe	14.000	356	16.000	406	14.000	356
HEA-1301-1X1-1-___0606	Enclosure, 1301 Regulator	6.375	162	9.000	229	8.375	213
HEA-0232-1X1-1-___0606	Enclosure, DE 232 Regulator, Basic	10.125	257	8.375	213	8.563	218
HEA-0461-1X1-2-___0808	Enclosure, Fisher 461-S Regulator Flanged	17.625	448	19.183	487	11.750	298
HEA-0461-3X3-1-___0808	Enclosure, Fisher 461-X57 Regulator, High Pressure	8.250	210	19.183	487	10.313	262
HEA-0600-1X1-2-___0808	Enclosure, 600 Series Reg, "BIG JOE"	12.125	308	14.125	359	10.188	259
HEA-0600-1X1-2-___0612	Enclosure, 600 Series Reg, "BIG JOE"	12.250	311	11.000	279	8.250	210
HEA-0600-1X1-2-___0612	Enclosure, 600 Series Reg, "BIG JOE", Flanged	12.250	311	11.000	279	8.250	210
HEA-0600-1X1-2-___1212	Enclosure, Fisher 600 Regulator	12.125	308	15.188	386	14.188	360
HEA-0627-1X1-2-___0808	Enclosure, Fisher 627 Regulator	12.125	308	12.500	318	7.500	191
HEA-627F-1X1-1-___1212	Enclosure, Fisher 627 Regulator Flanged	16.250	413	20.438	519	14.063	357
HEA-627F-1X1-1-___0808	Enclosure, Fisher 627 Regulator Flanged	16.250	413	20.438	519	14.063	357
HEA-0627-2X2-1-___0808	Enclosure, Fisher 627 Regulator	15.063	383	15.125	384	13.000	330
HEA-0627-1X1-1-___0808	Enclosure, Fisher 627 Regulator	15.063	383	15.125	384	13.000	330
HEA-0627-2X2-1-___1012	Enclosure, Fisher 627 Regulator	12.125	308	12.833	326	10.500	267
HEA-67CF-1X1-1-___0606	Enclosure, 67CF Regulator	6.438	164	9.000	229	8.375	213
HEA-600D-3X3-2-___1012	Enclosure, Similar to 600# Fisher D-Body Valve	21.625	549	15.625	397	12.500	318
HEA-0EZR-2X2-2-___1212	Enclosure, Fisher 2" EZR Regulator	20.625	524	28.125	714	23.125	587
HEA-0EZR-1X1-2-___1212	Enclosure, Fisher 1" EZR Regulator	20.625	524	28.125	714	23.125	587
HEA-0EZR-3X3-2-___1212	Enclosure, Fisher 3" EZR Regulator	20.625	524	28.125	714	23.125	587
HEA-0EZR-4X4-2-___1212	Enclosure, Fisher 4" EZR Regulator	20.625	524	28.125	714	23.125	587
HEA-0EZR-6X6-2-___1212	Enclosure, Fisher 6" EZR Valve, CL 600	20.625	524	28.125	714	23.125	587
HEA-0EZR-8X8-2-___1212	Enclosure, Fisher 6" EZR Valve 8" x 6" Pipe Size	20.625	524	28.125	714	23.125	587
HEA-MOON-2X2-2-___1212	Enclosure, Mooney Flowgrid Valve	14.750	375	14.125	359	14.125	359
HEA-TESC-2X2-1-___0612	Enclosure, Tescom Regulator	12.000	305	10.000	254	7.000	178
HEA-4413-1X1-1-___0606	Enclosure, Tescom 44-1300 Reg	11.125	283	10.313	262	8.750	222

\*Note: "\_" = WX, BX or WXS

# Pipe Preheater Enclosures



The Pipe Preheater Enclosure is designed to heat gas upstream of valves, chokes, orifice fittings and regulators. Commonly installed in locations where the valves, chokes, orifice fittings and regulators are not easily accessible.

## Features

- Enclosure comes fully assembled
- Stainless steel enclosures provide added longevity for the harshest environments
- Cata-Dyne™ heaters are CSA or FM certified, available in both natural gas or propane
- Optional thermostats and regulators are available
- Designed to clamp directly to the pipeline, spring clamps make installation easy
- Custom designed enclosure packages available upon request

Table 7 – Pipe Preheater Enclosures

Model No.	Description	Dimensions					
		L		W		H	
		in	mm	in	mm	in	mm
HEA-PP-2X2-2-WX0624	Enclosure, 2" Pipe Preheater	24.000	610	12.000	305	9.000	229
HEA-PP-3X3-2-WX1224	Enclosure, 3" Pipe Preheater	24.000	610	20.000	508	15.500	394
HEA-PP-4X4-2-WX1224	Enclosure, 4" Pipe Preheater Peeked Top	25.000	635	12.000	305	15.000	381
HEA-PP-2X2-2-WX12X24	Enclosure, 2" Pipe Preheater	24.000	610	20.000	508	16.000	406
HEA-PP-2X2-2-WX0612	Enclosure, 2" Pipe Preheater	16.375	416	9.250	235	12.250	311
HEA-PP-4X4-2-WX1224	Enclosure, 4" Pipe Preheater	12.625	321	20.000	508	36.0625	916
HEA-PP-1X1-2-WX1224	Enclosure, 1" Pipe Preheater Rectangular	36.000	914	13.000	330	20.000	508
HEA-PP-2X2-2-WX0624	Enclosure, 2" Pipe Preheater c/w Dual Gas Trains	24.000	610	13.000	330	9.000	229
HEA-PP-4X4-2-WX1248	Enclosure, 4" Pipe Preheater	51.000	1294	20.000	508	20.000	508
HEA-PP-3X3-2-WX1248	Enclosure, 3" Pipe Preheater	51.000	1294	21.000	533	15.000	381
HEA-PP-1X1-2-WX1248	Enclosure, 1" Pipe Preheater	51.000	1294	21.000	533	15.000	381
HEA-PP-2X2-2-WX1248	Enclosure, 2" Pipe Preheater, c/w 12x48	48.000	1219	28.000	711	15.000	381
HEA-PP-1.5X1.5-WX0624	Enclosure, 1.5" Pipe Preheater, Double 6x24 Heaters	24.000	610	12.000	305	9.000	229

## Model Coding

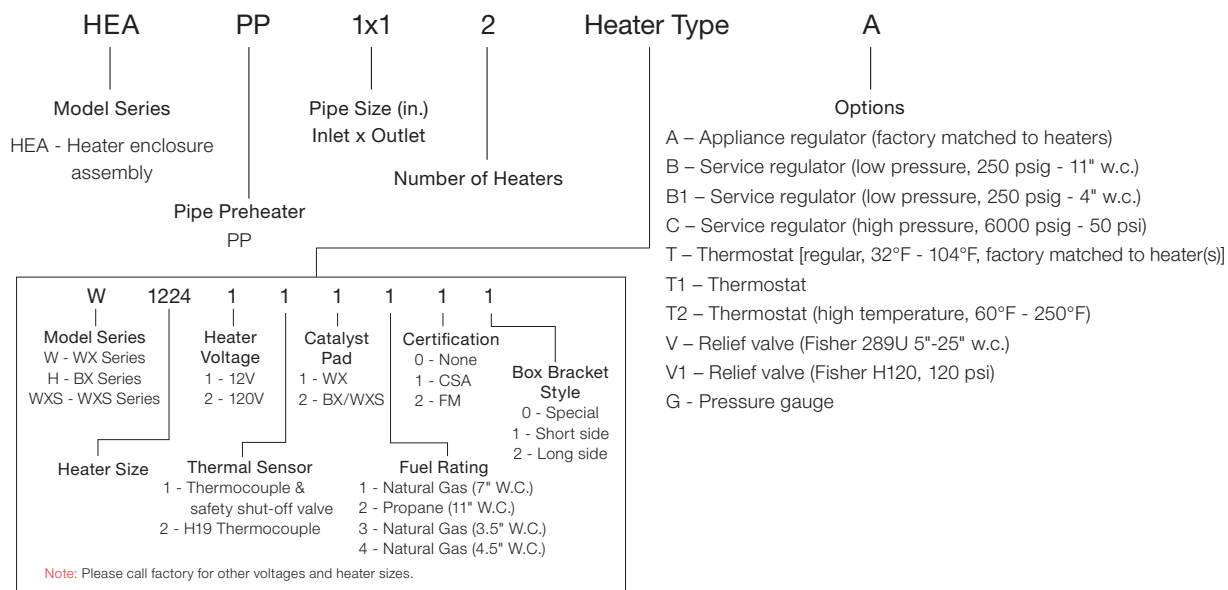

# Rotary Meter Enclosures

Rotary Meter Enclosures are designed to prevent freezing of wet gas and creation of hydrates that can cause meters to fail or provide inaccurate readings.

## Features

- Designed to suit many different rotary meter valves
- Enclosure comes fully assembled
- Stainless steel enclosures provide added longevity for the harshest environments
- Cata-Dyne™ heaters are CSA or FM certified, available in both natural gas or propane
- Optional thermostats and regulators are available
- Designed to clamp directly to the pipeline, spring clamps make installation easy
- Custom designed enclosure packages available upon request

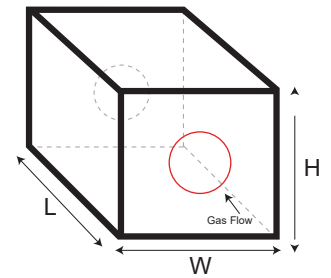
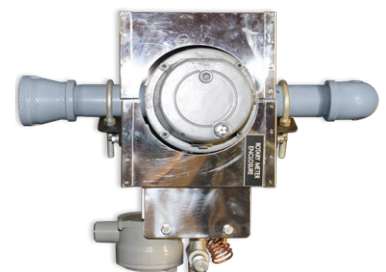
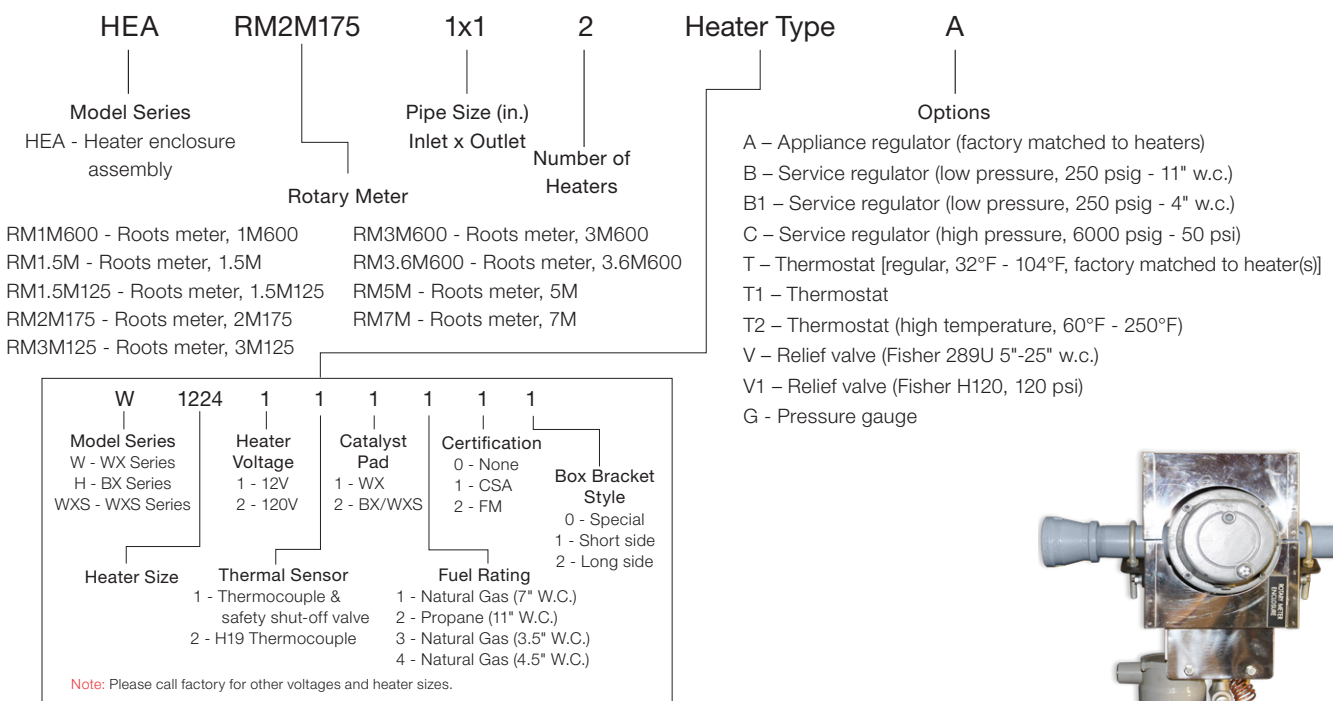

Figure 2

Table 8 – Rotary Meter Enclosures

Model No.	Description	Dimensions					
		L		W		H	
		in	mm	in	mm	in	mm
HEA-RM1M600-2X2-1-WX0808	Enclosure, Roots 1M600 Meter	15.00	381	14.50	368	15.00	381
HEA-RM1.5M-2X2-1-WX0808	Enclosure, Roots 1.5M Meter	10.00	254	11.00	279	10.00	254
HEA-RM2M175-2X2-1-WX0808	Enclosure, 2M175 Meter	12.00	305	12.00	305	10.00	254
HEA-RM3M125-2X2-1-WX0808	Enclosure, 3M125 Meter	12.00	305	12.00	305	10.00	254
HEA-RM3.6M600-2X2-1-WX0808	Enclosure, Roots 3.6M600 Meter	15.00	381	16.00	406	14.00	356
HEA-RM1.5M-3X3-1-WX0612	Enclosure, Roots 1.5M Meter	14.00	356	10.00	254	10.00	254
HEA-RM1M600-3X3-1-WX0612	Enclosure, Roots 1M600 Meter	16.00	406	14.00	356	14.00	356
HEA-RM3M125-2X2-1-WX0612	Enclosure, Roots 3M125 Meter	11.00	279	16.00	406	15.00	381
HEA-RM3M600-3X3-1-WX0612	Enclosure, Roots 3M600 Meter	15.00	381	15.00	381	14.00	356
HEA-RM5M-3X3-1-WX0808	Enclosure, Roots 5M	11.00	279	16.00	406	11.00	279
HEA-RM5M-3X3-1-WX0612	Enclosure, Roots 5M	11.00	279	16.00	406	11.00	279
HEA-RM7M-3X3-1-WX1012	Enclosure, Roots 7M	15.00	381	15.00	381	16.00	406

## Model Coding





# Motor Valve Enclosures

The Motor Valve Enclosure heats the critical portions of the motor valve to prevent freezing.

## Features

- Designed to ensure that all the sensitive portions of the valve are outside of the heated zone
- Enclosure comes fully assembled
- Stainless steel enclosures provide added longevity for the harshest environments
- Cata-Dyne™ heaters are CSA or FM certified, available in both natural gas or propane
- Optional thermostats and regulators are available
- Designed to clamp directly to the pipeline, spring clamps make installation easy
- Custom designed enclosure packages available upon request

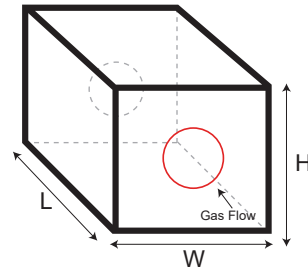
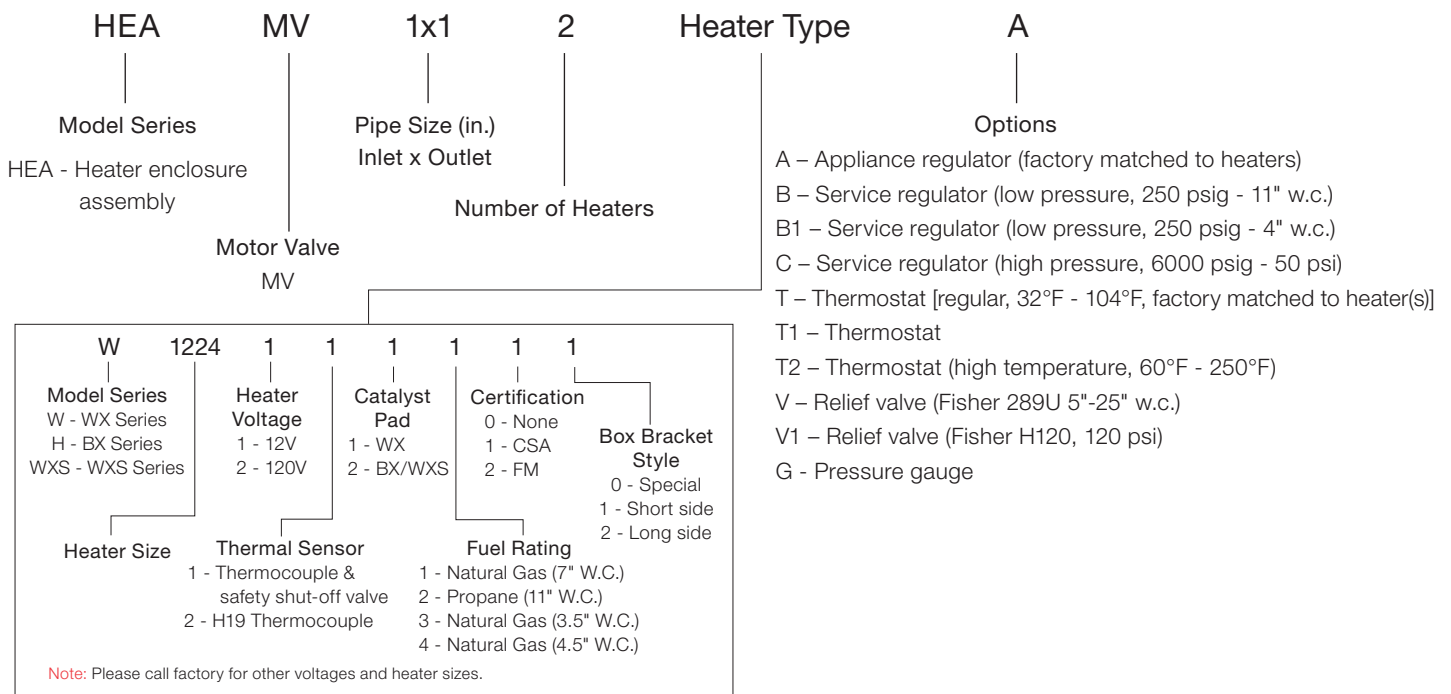

Figure 3

Table 9 – Motor Valve Enclosures

Model No.	Description	Dimensions					
		L		W		H	
		in	mm	in	mm	in	mm
HEA-MV1-1X1-1-WX10X12	Enclosure, 1" Motor Valve	9.625	244	12.000	305	14.125	359
HEA-MV2-2X2-2-WX10X12	Enclosure, 2" Motor Valve	14.000	356	9.500	241	12.000	305
HEA-MV1-1X1-2-WX0808	Enclosure, 1" Motor Valve	10.000	254	8.000	203	10.563	268

## Model Coding



# Orifice Fitting Meter Enclosures

The Orifice Fitting Meter Enclosure heats an orifice fitting directly. The enclosure has an easily accessible entry for the orifice fitting adjustment. The assembly is designed to heat natural gas passing through the orifice to prevent icing and the dropout of liquids.



## Features

- Designed to heat the orifice fitting directly
- Enclosure comes fully assembled
- Stainless steel enclosures provide added longevity for the harshest environments
- Cata-Dyne™ heaters are CSA or FM certified, available in both natural gas or propane
- Optional thermostats and regulators are available
- Custom designed enclosure packages available upon request
- Designed to clamp directly to the pipeline, spring clamps make installation easy
- Custom designed enclosure packages available upon request

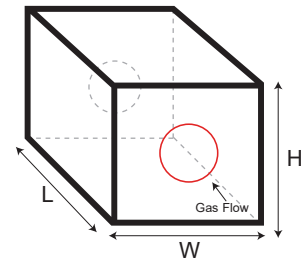
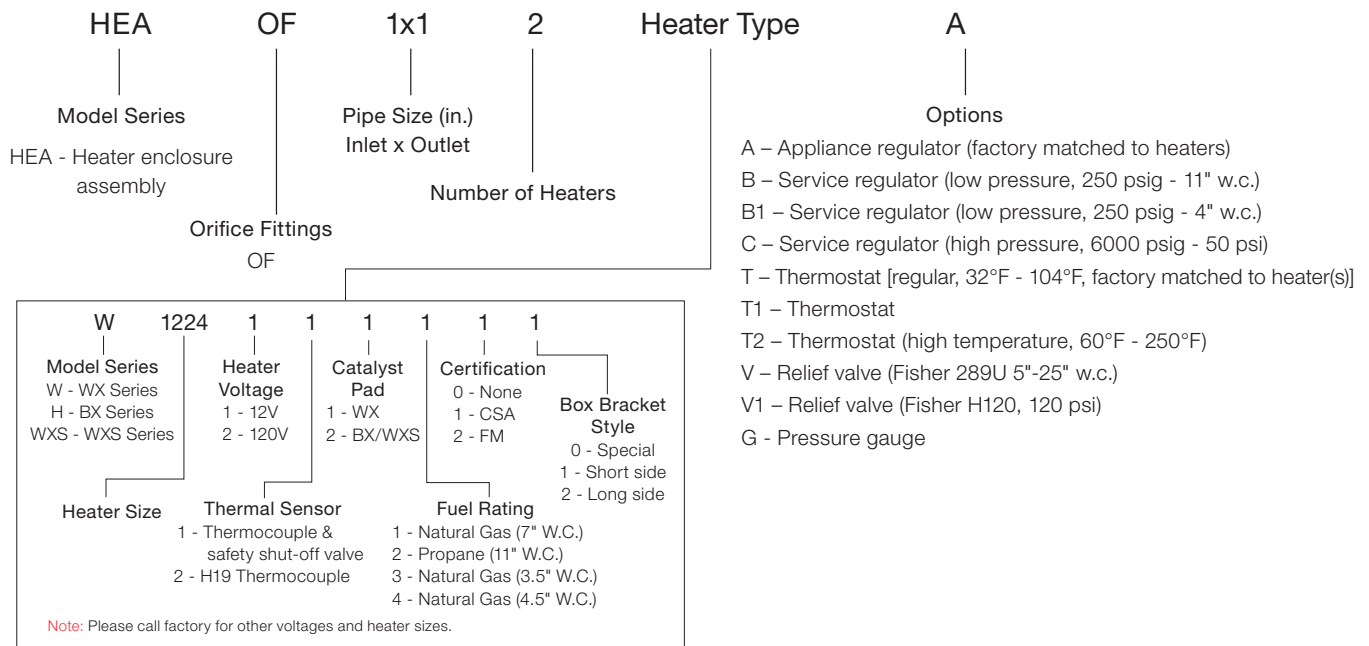

Figure 4

Table 10 – Motor Valve Enclosures

Model No.	Description	Dimensions					
		L		W		H	
		in	mm	in	mm	in	mm
HEA-OF-2X2-1-WX1012	Orifice Fitting	14	356	16	406	14	356
HEA-OF-3X3-1-WX1012							
HEA-OF-4X4-1-WX1012							

## Model Coding



# Super Conductors

The Super Conductor Enclosure's innovative design transfers heat using heat conducting rods, creating a moisture free heat source. The super conductor provides dry penetrating heat for small enclosures housing batteries, radio controls and other moisture sensitive equipment.

## Features

- Designed to keep instrumentation at an operable temperature
- Electrical power is not required to maintain operation after start-up
- Designed to operate for extended periods of time without maintenance
- Cata-Dyne™ heaters are CSA and FM certified, available in both natural gas and propane
- Custom sizes and designs available

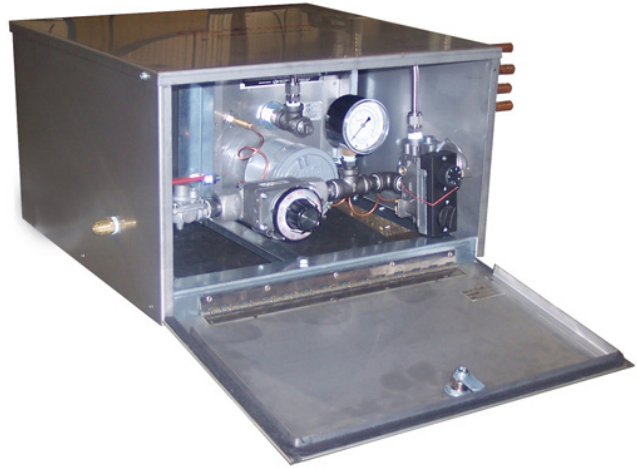

Table 12 – Super Conductor Enclosures

Part No.	Pipe Qty	Pipe Length		Heater Size	Length		Width		Height		Pipe Length	
		in	mm		in	mm	in	mm	in	mm	in	mm
SCH-4P-18-0808	4	18	457	8 x 8	17.30	439	17.20	437	10.40	264	8.50	216
SCH-4P-24-0808		24	610	8 x 8			17.2	437	10.40	264	14.50	368
SCH-4P-33-1212		33	838	12 x 12			19.00	478	14.75	375	19.50	495

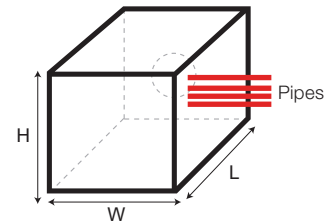
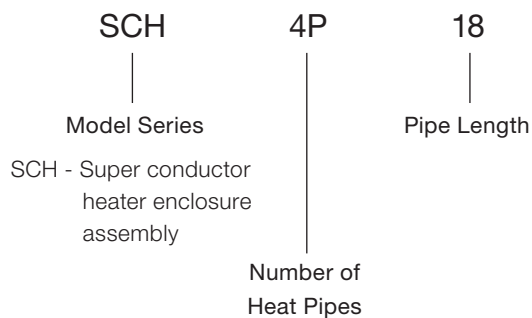
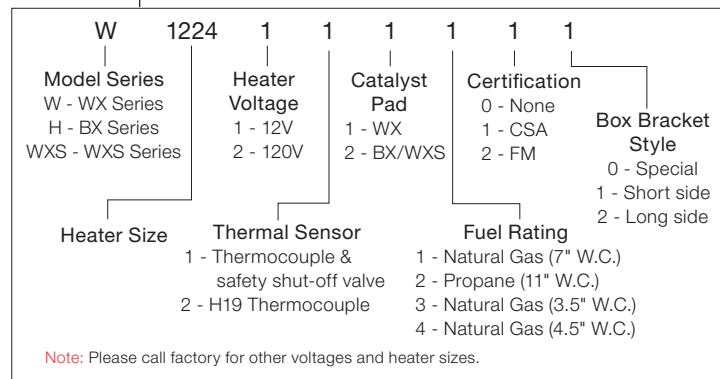

Figure 6

## Model Coding



## Heater Type



# Instrument Gas Preheaters

The Instrument Gas Preheater is the preferred solution for the natural gas industry, providing freeze protection for instrument supply gas, pilot actuated regulators and related applications.

## Features

- Stainless steel enclosure with both single & dual coil models
- Cata-Dyne™ heaters are CSA and FM certified, available in both natural gas and propane
- Operates for extended periods, without maintenance
- The compact unit helps eliminate the need for a separate facility to keep gas temperatures optimal
- Often used for gas chromatographs, valves, pilots and other low flow instruments
- Custom sizes and designs available

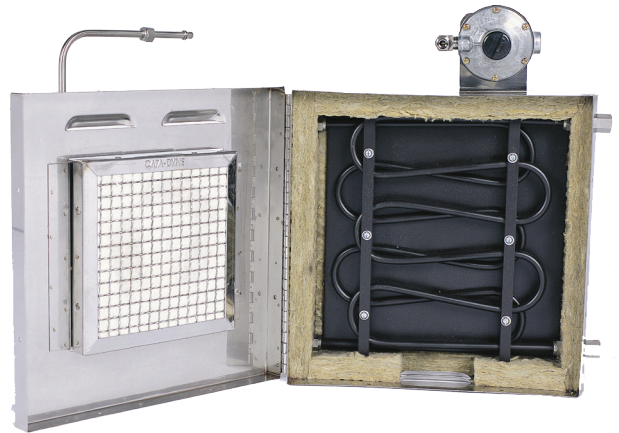

Table 13 – Instrument Gas Preheater

Part #	Coils	Heater Size		Length		Width		Height	
		in		in	mm	in	mm	in	mm
IGP-01-__0808	Single Pass	8 x 8	6	152	14	356	14	356	14
IGP-02-__0808	Double Pass							457	18
IGP-01-__1212	Single Pass	12 x 12	5	127	18	457	18	457	18
IGP-02-__1212	Double Pass							457	18

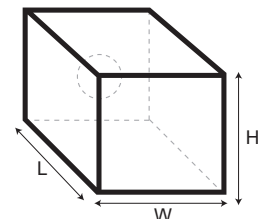
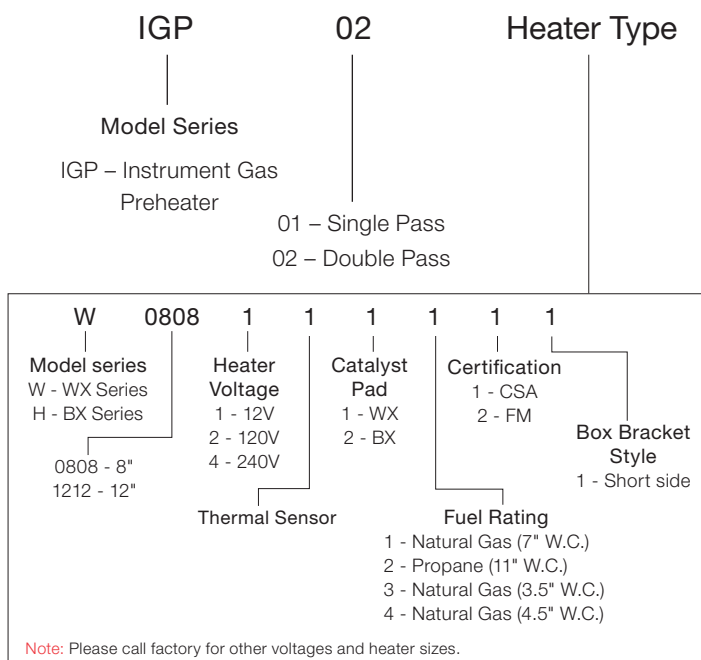

Figure 7

## Model Coding



## A

### Options

- A – Appliance regulator (factory matched to heaters)
- B – Service regulator (low pressure, 250 psig - 11" w.c.)
- B1 – Service regulator (low pressure, 250 psig - 4" w.c.)
- C – Service regulator (high pressure, 6000 psig - 50 psi)
- M – Wall mount bracket (not applicable to HEA)
- M1 – Pipe mount bracket (2" pipe size, U-Bolt mount)
- T – Thermostat [regular, 32°F - 104°F, factory matched to heater(s)]
- T1 – Thermostat
- T2 – Thermostat (high temperature, 60°F - 250°F)
- V – Relief valve (Fisher 289U 5"-25" w.c.)
- V1 – Relief valve (Fisher H120, 120 psi)

# Enclosure Request for Quote Form

## Enclosure Type

- Regulator                       Super Conductor  
 Pipe Preheater                 Instrument Gas Preheater  
 Rotary Meter                      Other (please specify):  
 Motor Valve                        
 Orifice Fitting

## Device to be Enclosed

Type of manufacturer, size, model:

## Temperature

- Gas inlet before device:  °F  °C  
 Temperature limit of enclosed device:  °F  °C  
 Gas outlet after device:  °F  °C

## Piping

- Diameter: Inlet (in)  Outlet (in)   
 Design temperature:  °F  °C  
 Design pressure (psig):

## Pressure

- Gas inlet before regulator or enclosure (psig):   
 Gas outlet after regulator of enclosure (psig):

## Gas Flow

- Maximum:  SCFM      Minimum:  SCFM

## Type of Gas Being Heated

- Natural Gas                       Super Conductor  
 Other (please specify):

## Electrical/Controls

- Supply Power:  V

## Hazardous Physical Dimensions Restrictions

Maximum:  L     W     H

Minimum:  L     W     H

Dimension Size:

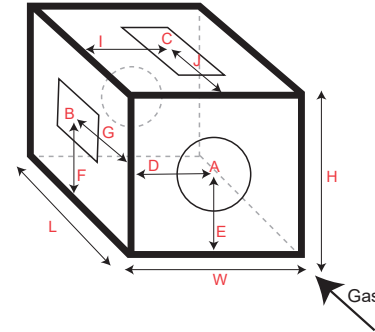

- A     E     I   
 B     F     J   
 C     G   
 D     H

Other Field Restrictions (please specify):

Available Drawings/Sketches:  Yes (please attach)     No

Available Photos:  Yes (please attach)     No

## Options

- Manual Shut-off Ball Valve  
 Filter:  H<sub>2</sub>S     Water     Oil     Particles  
 Filter Bypass Line

## Thermostat Control

- High temperature controller: 60°F to 250°F (15°C to 121°C)  
 Temperature controller: 32°F to 110°F (0°C to 43°C)

\*Please provide complete contact information when submitting request for quote.

# Sure Seal™ Pipeline Systems

The Cata-Dyne™ Sure Seal™ pipeline system is a unique infrared heating system consisting of a number of Cata-Dyne™ heaters mounted in a clamshell frame configuration to provide a safe and fast method of applying heat to the construction and maintenance of various sizes of pipeline systems.

## Applications

Large surface area of the Cata-Dyne™ heater allows for efficient transfer of infrared heat that can be utilized in a variety of pipeline applications.

- Suitable for preformed or wrap around sleeves
- Ideal for both preheat and shrink sleeve processes
- Can be used for baking to remove hydrogen induced cracking
- Appropriate for a variety of manufacturers' sleeves
- Can be used in windy or poor weather

## Features

- Utilizes the Cata-Dyne™ heater for high temperature applications
- Models available for 2" (51 mm) diameter or greater pipelines
- Requires no water, electricity or compressed air to operate
- Faster than tiger torch methods and uses less propane
- Portable and easily operated by one person, depending on pipeline sizes
- Custom built equipment and other options are available upon special request
- Utilizes the hottest catalytic gas heater on the market

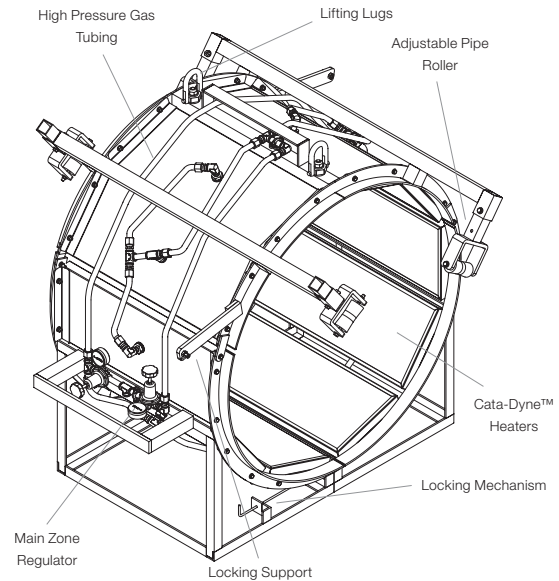
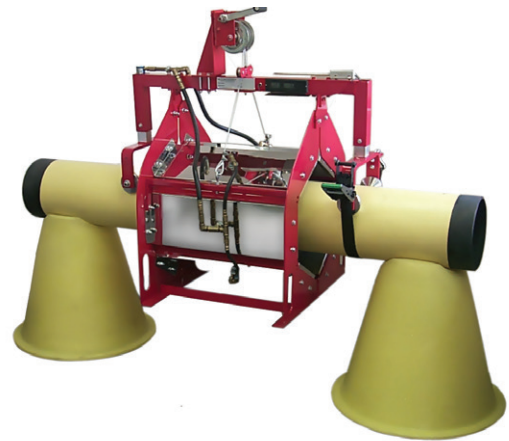

Figure 5

Table 11 – Sure Seal™ Pipeline Systems Dimensions & Data

Part No.	Pipe Dimensions								Weight		Approx. Propane Consumption
	Diameter		L		W		H		lbs	kg	
	in	mm	in	mm	in	mm	in	mm			lb/hr
SS2-4/24	2 to 4	51 to 102	40	1016	30	762	15	381	78	35	2.2
SS6-8/24	6 to 8	152 to 203			32	813	19	486	85	39	2.2
SS10-12/24	10 to 12	254 to 305			34	864	23	584	94	42	2.2
SS16-18/24	16 to 18	406 to 457			40	1016	28	714	122	55	3.8
SS20-24/36	20 to 24	508 to 610	52	1321	52	1321	40	1016	205	93	5.5

# FLO-DRI Series Compressed Gas Scrubbing Systems

The FLO-DRI gas scrubber removes gas contaminants including H<sub>2</sub>S, moisture, hydrocarbon, aerosols and particulate solids at point of use. All FLO-DRI filters are engineered for low cost and long life, featuring easy cartridge change out, low pressure drop and low maintenance.

## Applications

FLO-DRI gas scrubbers employ various media cartridges to remove moisture oil, H<sub>2</sub>S and particulate down to 0.5 micron in size, providing clean, dry gas for critical applications.

## Features

- Removes particulate down to 0.5 microns in size
- O-ring closure seal
- Working pressures up to 250 psig
- Variable flow rates with low pressure drop
- Drain cock
- Patented "quick change" filters
- Variety of filtration media available, including activated carbon, activated aluminum and molecular sieve



Table 14 – FLO-DRI Compressed Gas Scrubbing System

Scrubbing System	Model No.	PSIG	No. of Cartridges	Overall Length		Overall Diameter		Port to Port		Pipe Size NPT	Bed Cubic in <sup>2</sup>	Cartridge Media Part No.	
				in	mm	in	mm	in	mm				
Natural Gas	FLODRI-G10A	150	1	8.50	216	4.00	102	5.00	1270	1/4"	12.56	FLODRI-10AA FLODRI-10AC FLODRI-10MS	
	FLODRI-G25A	250	2	12.88	327	5.12	130	8.13	206	3/4"	30.78	FLODRI-25AA FLODRI-25AC FLODRI-25MS	
	FLODRI-G60A	250	3	18.25	464	6.25	159	12.38	314	1"	84.47	FLODRI-60AA FLODRI-60AC FLODRI-60MS	
	FLODRI-G100A	250	4	23.31	592	7.75	197	17.00	432	1 1/2"	199.06	FLODRI-100A FLODRI-100AC FLODRI-100MS	
	FLODRI-G150A	250	2	26.00	660	9.25	241	18.19	462	2"	376.52	FLODRI-150AA FLODRI-150AC FLODRI-150MS	
	Compressed Air	FLODRI-M10A	150	1	8.50	216	4.00	102	5.00	1270	1/4"	12.56	FLODRI-10R
		FLODRI-M25V	125	2	12.88	327	5.12	133	8.13	206	3/4"	30.78	FLODRI-25R
		FLODRI-M25A	250	2	12.88	327	5.12	133	8.13	206	3/4"	30.78	
		FLODRI-M60A	250	3	18.25	464	6.25	159	12.38	314	1"	84.47	FLODRI-60R
		FLODRI-M100A	250	4	23.31	592	7.75	197	17.00	432	1 1/2"	199.06	FLODRI-100R
FLODRI-M150A		250	2	26.00	660	9.25	241	18.19	462	2"	376.52	FLODRI-150R	

## Model Coding

<b>FLODRI</b>	<b>G</b>	<b>10</b>	<b>A</b>
Model Series FLO-DRI	Scrubbing System G – Natural Gas M – Compressed Air*	Pipe Size 10 - 1/4" 25 - 3/4" 60 - 1" 100 - 1 1/2" 150 - 2"	Barrel Material A - Aluminum V - Acrylic

\*Compressed air scrubbing systems includes air filter cartridges.

### G-10/M-10

- 150 psig maximum allowable pressure
- 1/4" NPT pipe size



### G-100/M-100

- 250 psig maximum allowable pressure
- 1 1/2" NPT pipe size



### G-25

- 250 psig maximum allowable pressure
- 3/4" NPT pipe size



### G-150/M-150

- 250 psig maximum allowable pressure
- 2" NPT pipe size

### G-60/M-60

- 250 psig maximum allowable pressure
- 1" NPT pipe size



### M-25

- 125 psig maximum allowable pressure
- 3/4" NPT pipe size
- For compressed air applications



## Replacement Cartridge Model Coding

FLODRI	10	AA
Model Series	Pipe Size	Natural Gas Cartridge Media
FLO-DRI	10 - 1/4"	AA - Moisture Removal
	25 - 3/4"	AC - Odor Removal
	60 - 1"	MS - H <sub>2</sub> S & Moisture Removal
	100 - 1 1/2"	Compressed Air Cartridge Media
	150 - 2"	R - Moisture Removal, Air Purifier

**Note:** To order specify model number and cartridge media part number.



# LH Series Natural Gas Line Heaters

The Cata-Dyne™ LH Line Heater prevents equipment freezing and possible hydrate formation during pressure reduction at natural gas regulating sites. The LH Line Heater heats the gas stream using infrared radiant heat transfer, eliminating the use of burners, glycol fluid and high maintenance heat exchange systems. It is also used to condition fuel gas for natural gas fired turbines or engines, and for heating gas and diluent streams in a variety of process applications. Custom engineered units for nonstandard applications are available.

The Cata-Dyne™ LH Line Heater's use of direct infrared heat transfer eliminates the need for traditional gas fired glycol bath systems. The elimination of glycol based heat transfer systems results in a more environmentally favourable installation. High field maintenance and operating costs are all eliminated by the Cata-Dyne™ LH Line Heater.

## Applications

Cata-Dyne™ Line Heaters are used for a variety of applications in the oil & gas, pipeline, midstream, gas distribution, and power generation industries. Common applications include:

- Heating high pressure natural gas prior to pressure reduction to prevent equipment freezing and the formation of hydrates.
- Conditioning fuel gas for natural gas fired turbines and engines.
- Heating of gas and diluent streams in a variety of process applications.

## Features

- Infrared radiant energy provided by the silent Cata-Dyne™ WX Gas Catalytic Heater is NOx free providing the cleanest and quietest heating system available.
- The flanged multi-pass coil heat exchanger is designed and built to the ASME B31.3 Code for Process Piping with Canadian Registration Number.
- Enclosures feature galvanized steel structures with stainless-steel cladding, limiting corrosion and maintenance.
- Control options from manual stop/start with and without temperature control to remote start/stop and automated feedback pneumatic or electric temperature control.
- Automatic units feature engineered control panels with PLC control systems.
- Infrared heat is accurately controlled to meet process temperature requirements while economizing operating costs.
- Standard high temperature shutdowns, optional low flow shutdowns available.
- Fuel gas system designed and built in accordance with CSA/Can – B149.1 and NFPA 54.
- Electrical system designed and built in accordance with CSA/Can – C22.2 and NEC (NFPA 70).
- Catalytic heaters conform to ANSI Z83.20a-2010/ CSA 2.34a-2010 standard for Gas-Fired Low Intensity Heaters and are CSA and FM certified for use in Class I, Division 1 or 2, Group D hazardous locations.



Table 15 – Line Heaters

Model No.	Heater Input (Btu/hr)		External Dimensions in (mm)
	Min.	Max.	Length x Width x Height
LH-40	10,000	40,000	56 x 48 x 84 (1420 x 1219 x 2130)
LH-60	15,000	60,000	
LH-80	20,000	80,000	
LH-100	25,000	100,000	78 x 68 x 90
LH-160	40,000	160,000	(1980 x 1725 x 2286)

## Hybrid Capabilities

Only Thermon Heating Systems, Inc. offers the optional Catalytic/Electric Hybrid Line Heater. A secondary electric gas circulation heater is used to augment the capabilities of the base catalytic line heater. The hybrid design provides enhanced responsiveness to gas flow transients and deeper turn-down capabilities.

### Note:

1. Custom designs and Btu ratings are available upon request.
2. Heater output between minimum and maximum values is manually selected on manual and sequential models.
3. Automatic zone control is only available with the automatic model.

# Model Coding

LH	40	M	NT	12	1	600
Model Series LH – Line Heater		Start-up Type M - Manual S - Sequential A - Automatic (engineered option)		Start-up Voltage (VAC) 12, 120, 208, 240, 480, 600  *Custom LH-160 and above		Flange Rating 600 - 600 ANSI 900 - 900 ANSI
	Heater Input 40 - 40,000 Btu/hr 60 - 60,000 Btu/hr 80 - 80,000 Btu/hr 100 - 100,000 Btu/hr 160 - 160,000 Btu/hr		Temperature Control NT - Fixed heat output, outlet temperature not controlled T* - Variable heat output, low/high, outlet temperature controlled.  *Variable control from 40% to 100% of heater output.		Flange Size 1 - 1" 2 - 2" 3 - 3"	

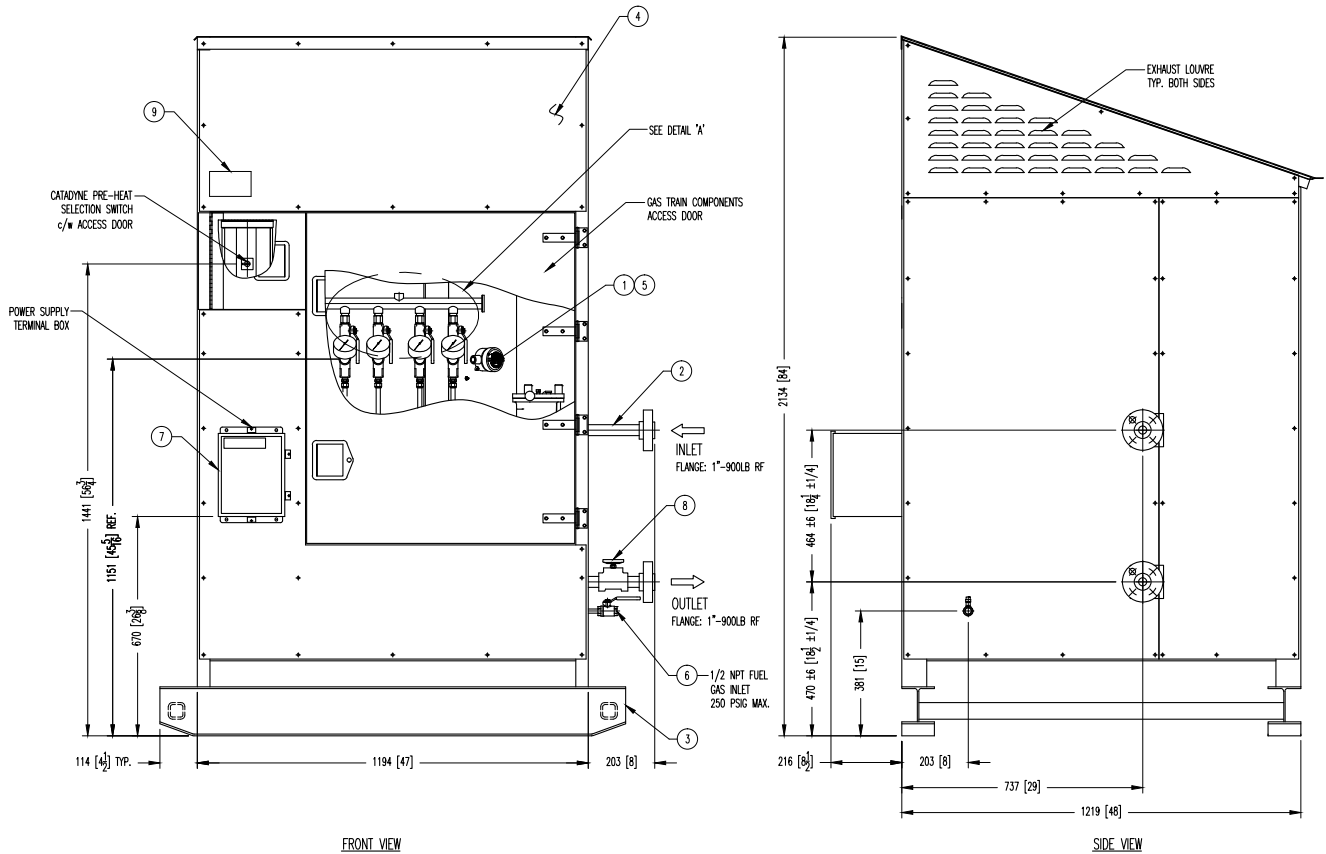

Figure 8 – Cata-Dyne™ Line Heater

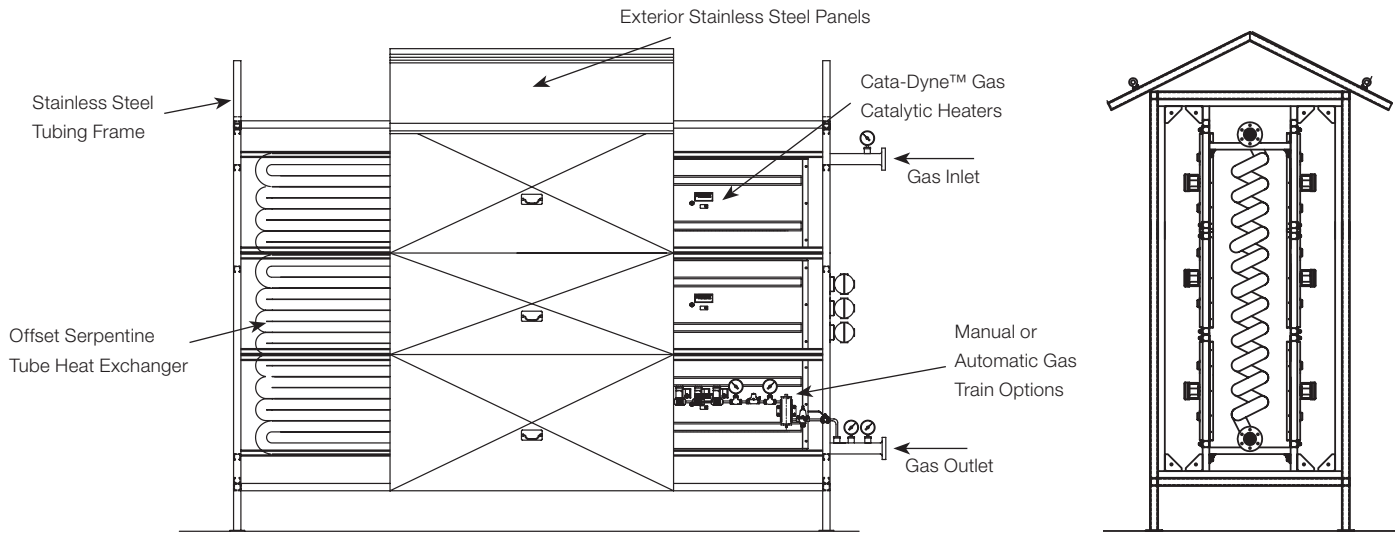
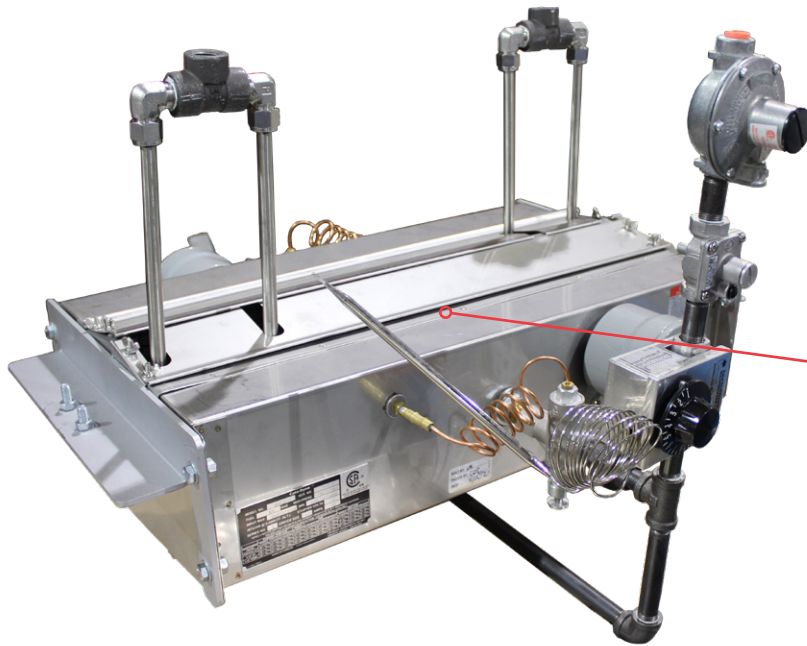

Figure 9 – Cata-Dyne™ Custom Engineered Line Heater

# MLH Series Micro Line Heaters



The heart of each Micro Line Heater is the standard Cata-Dyne™ WX Heater. The Cata-Dyne™ WX Heater is the first and only explosion-proof catalytic heater in North America to conform to the new ANSI Z83.20b-2011/CSA 2.34b-2011 standard for Gas-Fired Low Intensity Heaters.



Figure 10

The Cata-Dyne™ Micro Line Heater prevents equipment freezing and possible hydrate formation during pressure reduction at natural gas regulating sites. The Micro Line Heater heats the gas stream using infrared radiant heat transfer, eliminating the use of burners, glycol fluid and high maintenance heat exchange systems. Custom engineered units for nonstandard applications are available.

The Cata-Dyne™ Micro Line Heater's use of direct infrared heat transfer eliminates the need for traditional gas fired glycol bath systems. The elimination of glycol based heat transfer systems results in a more environmentally favourable installation. High field maintenance and operating costs are all eliminated by the Cata-Dyne™ Micro Line Heater.

## Features

- Allows for installation in existing facility by mounting onto 1" and 2" piping reducing installation costs
- Certified for use in Class I, Division 1 & 2, Group D locations
- Conforms to CSA B149.3
- Meets the new ANSI Z83.20a-2010/CSA 2.34a-2010. Sizes available from 10,000 to 40,000 Btu
- Handles between 40 to 130 Mcf/D of Natural Gas
- With pressure reductions as high as 1200 psi down to 50 psi without freeze-offs
- Simple thermostat controls allowing for easy adjustment

## Benefits

- Ideal for lower flow conditions where Glycol Water Bath systems are excessive
- Approximately ¼ of the cost of standard glycol water bath system
- No glycol
- Simple start-up allows for system to be shut-down and started as required during low/zero flow conditions
- Reduced maintenance

# Standard Micro Line Heater Sizes

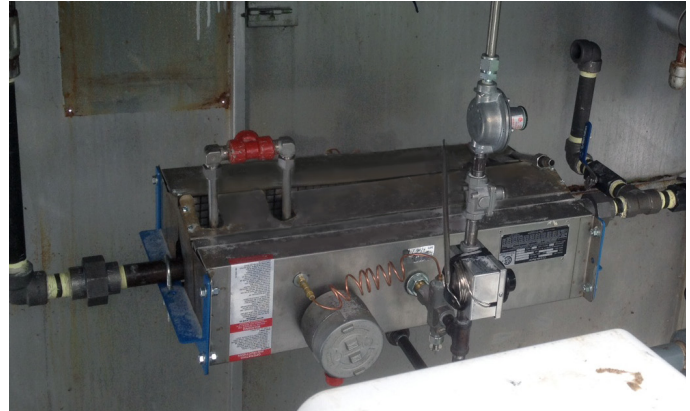
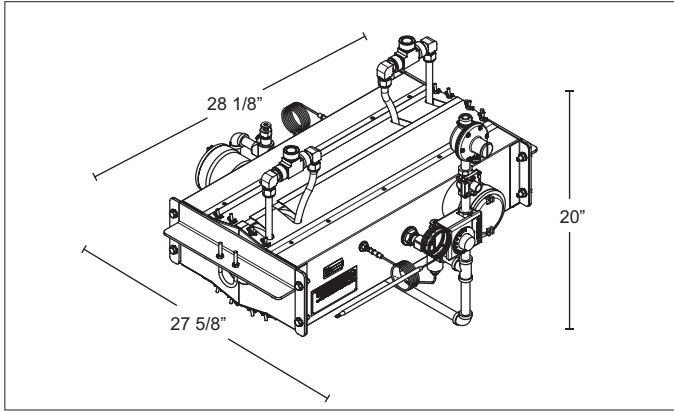

Figure 11 – 6" x 24" Single Coil

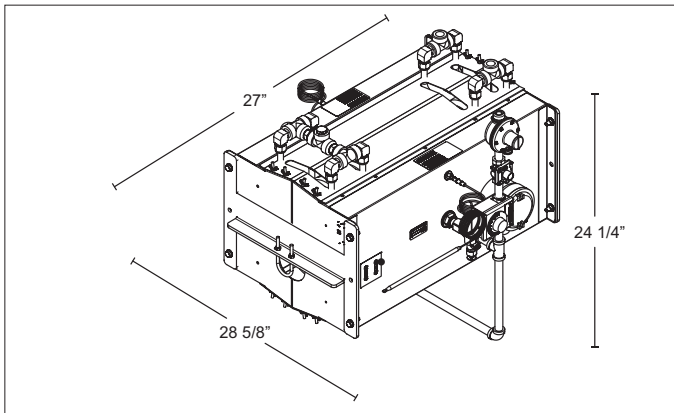

Figure 12 – 12" x 24" Double Coil

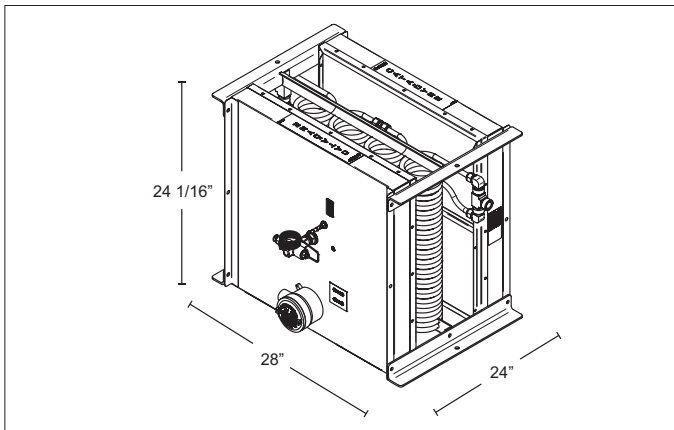

Figure 13 – 24" x 24" Quad Coil

# CHS Series Cata-Dyne™ Heating Package



The Cata-Dyne™ CHS Series Heating Package is the industry standard for space and spot heating applications where flammable gases, vapours or liquids may be present. Equipped with explosion-proof infrared heaters, this package comes standard or custom designed to meet any unique application.

The Cata-Dyne™ infrared heaters are controlled either manually or with an integrated hazardous locations control panel.

## Applications

Comfort heating for industrial buildings, CNG, LNG or propane vehicle maintenance facilities and freeze protection for equipment and components.

## Control Panel Features

- Single switch **"ON"/"OFF"/"STANDBY"** control
- -18°C to 38°C (0°F to 100°F) thermostat
- Interlock terminals for integration with ancillary equipment
- Custom options available
- CSA C/US certified for Class I, Division 2, Group D, or optional UL<sub>c</sub> certification for Class I, Division 1, Group D, IEC Ex
- Expandable to 6 zones
- Touch screen option for CSA Class 1, Division 2
- Exhaust fan control

## Control Panel Benefits

- Single point control of multiple heaters
- Floor level access to all control functions
- Interlock terminals for remote "Enable" & "Standby"
- Self diagnostic fault indication
- Optional remote thermostat for each zone

## Heater Features

- Proprietary Cata-Dyne™ catalyst pad
- Corrosion resistant 300 series stainless-steel construction
- Natural gas or propane operation
- Electric start available in 120V to 600V
- Individual heater models range from 8,000 to 48,000 Btu/hr
- CSA certified for use in Class I, Division 1 & 2, Group D hazardous locations
- Certified to ANSI Z83.20a-2010/CSA 2.34a-2010
- NFPA30A Compliant

## Heater Benefits

- No moving parts and designed to operate indefinitely when supplied with clean fuel and adequate ventilation
- Heaters can be strategically positioned to optimize heat distribution

Table 16 – Control Panel Capacities - Heaters/Controllers Per Zone

Heater		Preheat Wattage					Max. Number of Heaters (Max. Current)						
Size	Btu/hr Rating	120V	208V	240V	480V	600V	120V AC	208V AC	240V AC	208V AC	240V AC	480V AC	600V AC
							1Ø			3Ø			
12x24	8000	500	500	500	700	550	48 H (200 A)	48 H (115 A)	48 H (100 A)	48 H (66.7 A)	48 H (57.8 A)	48 H (40.5 A)	48 H (25.4 A)
12x36	12000	600	600	600	600	600	48 H (240 A)	48 H (138 A)	48 H (120 A)	48 H (80.0 A)	48 H (69.4 A)	48 H (34.7 A)	48 H (27.7 A)
12x48	16000	800	800	800	800	800	42 H (280 A)	48 H (185 A)	48 H (160 A)	48 H (107 A)	48 H (92.5 A)	48 H (46.2 A)	48 H (37.0 A)
12x60	20000	1250	1250	1250	1250	1250	27 H (281 A)	48 H (288 A)	48 H (250 A)	48 H (167 A)	48 H (145 A)	48 H (72.3 A)	48 H (57.8 A)
12x72	24000	1450	1450	1450	1450	1450	23 H (280 A)	39 H (272 A)	47 H (284 A)	48 H (193 A)	48 H (168 A)	48 H (83.8 A)	48 H (67.1 A)
18x24	12000	500	500	500	700	-	48 H (200 A)	48 H (115 A)	48 H (100 A)	48 H (66.7 A)	48 H (57.8 A)	48 H (40.5 A)	N/A
18x36	18000	1200	1200	1200	1200	1200	28 H (280 A)	48 H (277 A)	48 H (240 A)	48 H (160 A)	48 H (139 A)	48 H (69.4 A)	48 H (55.5 A)
18x48	24000	1600	1600	1600	1600	1600	21 H (280 A)	36 H (277 A)	42 H (280 A)	48 H (213 A)	48 H (185 A)	48 H (92.5 A)	48 H (74.0 A)
18x60	30000	2500	2500	2500	2500	2500	13 H (271 A)	24 H (288 A)	27 H (281 A)	39 H (271 A)	45 H (271 A)	48 H (145 A)	48 H (116 A)
18x72	36000	2900	2900	2900	2900	2900	11 H (266 A)	20 H (279 A)	23 H (278 A)	33 H (266 A)	39 H (272 A)	48 H (168 A)	48 H (134 A)
24x24	16000	500	500	500	700	-	48 H (200 A)	48 H (115 A)	48 H (100 A)	48 H (66.7 A)	48 H (57.8 A)	48 H (40.5 A)	N/A
24x30	20000	500	500	500	700	-	48 H (200 A)	48 H (115 A)	48 H (100 A)	48 H (66.7 A)	48 H (57.8 A)	48 H (40.5 A)	N/A
24x36	24000	1200	1200	1200	1200	1200	28 H (280 A)	48 H (277 A)	48 H (240 A)	48 H (160 A)	48 H (139 A)	48 H (69.4 A)	48 H (55.5 A)
24x48	32000	1600	1600	1600	1600	1600	21 H (280 A)	36 H (277 A)	42 H (280 A)	48 H (213 A)	48 H (185 A)	48 H (92.5 A)	48 H (74.0 A)
24x60	40000	2500	2500	2500	2500	2500	13 H (271 A)	24 H (288 A)	27 H (281 A)	39 H (271 A)	45 H (271 A)	48 H (145 A)	48 H (116 A)
24x72	48000	2900	2900	2900	2900	2900	11 H (266 A)	20 H (279 A)	23 H (278 A)	33 H (266 A)	39 H (272 A)	48 H (168 A)	48 H (134 A)

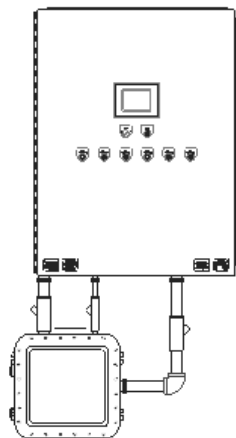

Figure 14 – Typical for 6 Stages (Hazardous Location Control Panel)

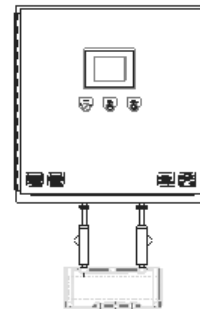

Figure 15 – Typical for 1 Stage Unit (Hazardous Location Control Panel)

# Accessories

In many typical oil & gas applications that are classified as Class I hazardous locations, the Cata-Dyne™ heater must be installed in accordance with CSA and FM codes and regulations. As a result, the Cata-Dyne™ product line is supported with essential accessories required to ensure the safe and efficient operation of the units.



## Safety Shut-Off Valves

- The safety shut-off valve works in conjunction with the thermocouple to monitor the catalytic reaction ensuring it is well established before fuel supply remains on unattended
- Designed to automatically shut off the gas supply to the heater if the thermocouple senses that the catalyst pad has dropped below the activation temperature
- Two styles are available to suit your heating application needs

### ASV375 - Safety Shut-Off Valves

- 3/8" NPT connections and a maximum inlet pressure of 1/2 psi
- Designed with a pilot test port located at the base of the valve that can be used to measure operating pressure

Part No.	Description
Valve - ASV375	Safety Shut-Off Valve & Thermostat

### ASV375NT - Safety Shut-Off Valves

- The ASV375NT valve includes an additional tamper-resistant design discouraging mechanical attempts to fix the valve open and override it's safety feature
- 3/8" NPT connections and a maximum inlet pressure of 1/2 psi

Part No.	Description
Valve - ASV375NT	Tamper-Proof Safety Shut-Off Valve

### Mertik Combination Gas Controls/Valves

- Designed as a non-electric combination of the safety shut-off valve and a thermostat control
- Includes a tamper-resistant thermocouple connection that cannot be mechanically fixed open

Part No.	Description
AC-GV33	Combination Gas Control/Valve

- Certifications
  - Mertik - CSA approved and CE certified
  - ASV375 and ASV375NT - CSA approved

## Thermostatic Temperature



# Control Valve



- This valve is designed with a bulb and capillary assembly that automatically regulates fuel flow to a Cata-Dyne™ heater from 100% when heat is required to approximately 30% when the thermostat is satisfied
- This unit is used to control building temperature for spot and space heating applications
- The sensing bulb is filled with a temperature sensitive liquid. Changes in the temperature at the bulb expand and contract the liquid on temperature rise and fall causing the internal mechanism to modulate the flow of fuel
- Temperature control range of 0°C to 44°C (32°F to 110°F)
- Maximum inlet pressure of 1/2 psi
- Each unit has a connection size of 3/8" NPT female and a capillary length of 5 ft (1.5 m)
- No electrical power is required to operate this unit
- Controls are factory set to specific Btu and fuel ratings for specific heater types and sizes. Contact factory for the appropriate thermostat control valve.
- Certifications
  - CSA approved

Part No.	Description
AC-TC	0°C to 44°C (32°F to 110°F)

# Manual Shut-Off Ball Valve



- The ball valve is installed upstream of all auxiliary heater controls to manually shut-off the fuel supply to the Cata-Dyne™ heater, see installation instructions for correct configuration for each fuel type
- A 3/8" NPT shut-off ball valve, with female NPT inlet and outlets in forged brass which increases the strength of the body
- Supplied with all manually controlled Cata-Dyne™ heaters
- The hard chrome-plated ball has Teflon seats and an anti-corrosion Dacromet treated handle
- Certifications
  - CSA approved and UL listed

# Thermocouples



- The Type K Thermocouple is a probe made from two dissimilar metals that monitors the temperature of both the electrical start-up element and the underside of the catalyst pad inside the Cata-Dyne™ heater
- Certifications
  - Thermocouples are CSA approved

# Gas Pressure Regulators

- All regulators are designed to ensure there is a precise control of gas or propane flow
- The regulators are part of the piping system connecting to the Cata-Dyne™ units, see installation and operating instructions for precise configuration
- The following three types of regulators are available: Appliance Regulators, Service or Low Pressure Regulators and High Pressure Regulators

## Standard Appliance Regulator (AC-R-ES404-7)

- The appliance regulator is used for controlling the manifold pressure on all natural gas Cata-Dyne™ heaters and is supplied with all CSA certified models
- It is a spring type, nonadjustable appliance regulator with a maximum inlet pressure ½ psig
- Available pressure outlet settings are: 3.5", 4.5" and 7.0" w.c.
- Maximum flow capacity: 65,000 Btu/hr
- Certifications
  - Appliance regulators are CSA approved



## Standard Service or Low Pressure Regulator (AC-R-2511)

- Used as an appliance regulator for all model sizes of Cata-Dyne™ heaters operating on LPG, and serves as a natural gas low pressure line regulator when used in conjunction with the ES-404 gas appliance regulator
- Self-operated, spring loaded device that is field adjustable
- It has a maximum inlet pressure of 250 psig and is factory set at 11" w.c. or 4.5" w.c. outlet pressure, with a connection size of 1/4" NPT inlet by 3/8" NPT outlet
- For gas applications with inlet gas less than 25 PSI use service regulator AC-R-HSR or AC-R-325
- Ambient temperature range: -40°C to 55°C (-40°F to 130°F) or -29°C to 70°C (-20°F to 160°F) (Fisher regulator only)
- 1/8" NPT screwed vent connection is provided
- Certifications
  - Low pressure regulators are CSA approved

Table 17 – Other Service Regulators Available

Part No.	Description
AC-R-325-3	Low Pressure Regulator 5 psig - 11" wc (2.7 kPa)
AC-R-325-US	Low Pressure Regulator - CSA Approved 5 psig - 4-12" wc (1.0 to 3.0 kPa)
AC-R-HSR-11	Low Pressure Regulator 125 psig - 11" wc (1.1 kPa)
AC-R-HSR-5	Low Pressure Regulator 125 psig - 4.5" wc (1.1 kPa)

## High Pressure Regulator (AC-R-1301F)

- Maximum pressure of 6,000 psig inlet pressure and is factory set at 50 psig outlet pressure
- Connection size is 1/4" NPT (one inlet and two outlets)
- Certifications
  - High pressure regulators are UL listed

# Battery Cables/Electric Start Up Leads

- Are used for starting a 12V Cata-Dyne™ heater from a battery or other power supply
- Each set of cables comes with heavy duty spring loaded serrated jaw clamps at one end and closed loop terminal ends the other
- A strain relief connector is attached at the terminal end to enable the user to seal the connection between the cable and the junction box
- Lengths are available in 25 ft (7.6 m), 30 ft (9.14 m), and 40 ft (12.19 m)



Part No.	Description
AC-LEAD-25	25 ft. Lead
AC-LEAD-30	30 ft. Lead
AC-LEAD-40	40 ft. Lead

## Battery Cable Cabinet

- This mountable storage cabinet is a convenient solution for storing battery start-up leads, offering protection from adverse weather conditions
- Each cabinet is manufactured from heavy duty 20-gauge stainless steel, and can be used with all lengths of battery cables from 25 ft to 40 ft (7.6 m to 12.2 m)
- The units are lockable and easy to install



Part No.	Description
IN-BATBOX	Battery Cable Cabinet

# Fuel Gas Hose

- Versatile braided rubber fuel hose
- These hoses have a 350 psi maximum working pressure, and are available in lengths of 5, 10, 15 and 20 ft (7.6 m to 12.2 m). Other custom sizes are available
- The connection size at each end is 3/8" NPT male
- Certifications
  - CSA approved Type 1 natural and propane gas hose

Part No.	Description
AC-HOSE-10	10 ft. Hose
AC-HOSE	15 ft. Hose
IN-P-H-3/8 x 20 ft.	20 ft. Hose
IN-P-H-3/8 x 25 ft.	25 ft. Hose
IN-P-H-3/8 x 30 ft.	30 ft. Hose

# Protection Grilles

Two types of protection grilles are available to protect personnel and objects from coming into direct contact with the face of the Cata-Dyne™ heater.

## Strap-On Grilles

- Comes with four straps on all corners so the grille can be bolted to the heater box
- Can be bolted to a variety of standard Cata-Dyne™ heaters
- The bolting hardware is included in the purchase

**Note:** Cannot be used with MKII units. Not available for all sizes.

## Snap-On Grilles

- These snap on to the bezel of the Cata-Dyne™ heater
- Available in a variety of sizes
- They do not require any additional hardware or tools to install
- MKII units accept this style only

**Note:** Can only be used with units manufactured after September 1, 2002.



# Gas Pressure Test Kit

- Pressure gauge and PVC tube used to accurately test and measure the gas pressure going into a Cata-Dyne™ heater by connecting the tube end to the gas test port of the Safety Shut-Off Valve
- Portable kit, ideal for all heater sizes
- Eliminates the need to fit test ports on pipelines used for heater operation
- Includes a 15" w.c. (3.7 kPa) pressure gauge, a 6 ft (1.8 m) PVC tube and the connection to the SSOV
- Compatible with both natural gas and propane heaters

# POL Adapters

- Propane fitting adapter used as a straight adapter that reduces a propane cylinder adapter to 1/4" NPT
- Full flow brass fitting with a 7/8" (22 mm) hex nut



# Stratafan™

Stratafan™ produces up to 150 cfm of air flow promoting uniform distribution of heat within enclosed areas, reducing temperature stratification and ventilation dead spots. This thermoelectric fan is self powered by a thermoelectric generator and has a cast aluminum housing.



- Certifications
  - CSA certified for Class I, Divisions 1 & 2, Group D Hazardous locations; certified to temperature code T3C

# Vent Hood Assembly

- A light weight galvanized steel construction venting system for use with the Cata-Dyne™ heater to vent the by-products of reaction (carbon dioxide and water vapour) outside the building
- Each assembly consists of 1 exhaust hood, 1 length of vent pipe 30" (762 mm), 1 elbow, 1 flashing, and 1 snowcap
- Assemblies available for both standard Cata-Dyne™ heaters and MKII models (12" and 24")
- The above parts can be ordered individually



Part No.	Width	
	in	mm
AC-VHASSY-6	6	152
AC-VHASSY-8	8	203
AC-VHASSY-12	12	305
AC-VHASSY-24	24	610
AC-VHASSY-36	36	914
AC-VHASSY-48	48	1219
AC-MKIIVHASSY-12	MKII - 12	305
AC-MKIIVHASSY-24	MKII - 24	610

# Wall Mounting Brackets

- Optional stainless steel or mild steel constructed mounting brackets and hardware
- Standard wall brackets can mount Cata-Dyne™ heaters 7.5" (190 mm) away from the wall to allow access to the back of the heater
- MKII model bracket sizes are half the length of our standard wall mounting brackets allowing the heater to be installed closer to the wall
- Brackets for large units over 8,000 Btu/hr (2.3 kW) are manufactured from heavy gauge mild steel flat bar



Part No.	Heater Size (in)
AC-WBRK-08	8x8
AC-WBRK-06	6x24
AC-WBRK-12	12x12
AC-WBRK-12	12x24
AC-WBRK-12	12x36
AC-WBRK-12	12x48
AC-WBRK-12	12x60
AC-WBRK-12	12x72
AC-WBRK-1824	18x24
AC-WBRK-1836	18x36
AC-WBRK-1848	18x48
AC-WBRK-1860	18x60
AC-WBRK-1872	18x72
AC-WBRK-2424	24x24
AC-WBRK-2430	24x30
AC-WBRK-2436	24x36
AC-WBRK-2448	24x48
AC-WBRK-2460	24x60
AC-WBRK-2472	24x72

## 45° Wall Mount Brackets

- Specialized mounting angle brackets used to simplify the installation of all 18" and 24" Cata-Dyne™ heaters
- Manufactured from mild rolled steel with a zinc plated finish

Part No.	Description - Mounting Angle Bracket
AC-WBRK-1824-45	18 x 24, Short Side
AC-WBRK-1836-45	18 x 36, Long Side
AC-WBRK-1848-45	18 x 48, Long Side
AC-WBRK-1860-45	18 x 60, Long Side
AC-WBRK-1872-45	18 x 72, Long Side
AC-WBRK-2424-45	24 x 24, Long Side
AC-WBRK-2436-45	24 x 36, Long Side
AC-WBRK-2448-45	24 x 48, Long Side
AC-WBRK-2460-45	24 x 60, Long Side
AC-WBRK-2472-45	24 x 72, Long Side

# Floor Stands

- 12-gauge galvanized steel construction and hardware
- Allows the heater to be placed closer to an object than the wall mounting system
- Floor stands are adjustable, allowing the unit to be moved to the optimum height for the required heating application

Part No.	Description
AC-FSS-8	8x8
AC-FSS-24	6x24
AC-FSS-12	12x12
AC-FSS-24	12x24
AC-FSL	12x36
	12x48
	12x60
	12x72
	18x24
	18x36
	18x48
	18x60
	18x72
	24x24
	24x30
	24x36
	24x48
	24x60
24x72	



# Conversion Data

1000 Btu/hr = 0.2929 kW or 292.9 W

1000 Btu = 1.054 MJ

3,412 Btu/hr = 1.0 kW

1 psi = 27.91 inches w.c.

1 psi = 6.895 kPa

1 inch w.c. = 0.247 kPa

1 standard cubic foot NAT Gas = 1000 Btu

1 standard cubic foot LPG = 2,500 Btu

1 standard cubic meter NAT Gas = 37 MJ

1 standard cubic meter LPG = 88 MJ

1 pound LPG = 21,560 Btu

1 kilogram LPG = 50.1 MJ

3.5 inches w.c. = 8.7 mbar = 0.87 kPa = 0.126 psi

4 inches w.c. = 9.9 mbar = 0.99 kPa = 0.144 psi

7 inches w.c. = 17.3 mbar = 1.73 kPa = 0.251 psi

11 inches w.c. = 27.2 mbar = 2.72 kPa = 0.394 psi

$^{\circ}\text{C} = (^{\circ}\text{F} - 32) \times (5/9)$

$^{\circ}\text{F} = (9/5 \times ^{\circ}\text{C}) + 32$

1 ft = 0.3048 m

1 ft<sup>2</sup> = 0.09290304 m<sup>2</sup>

1 ft<sup>3</sup> = 0.02831685 m<sup>3</sup>

1 in = 2.54 cm

1 in<sup>2</sup> = 6.4516 cm<sup>2</sup>

1 in<sup>3</sup> = 16.38706 cm<sup>3</sup>

1 psi = 27.91 in. w.c.

1 in. w.c. = 0.247 kPa

1 cfm = 0.028312 m<sup>3</sup>/hr

# Inverse Square Law

Intensity of infrared energy is inversely proportional to the square of the distance from the source of energy.

For infrared energy, this translates to:  $I = P/4\pi r^2$

Where: I = intensity of infrared at the heated object

P = total power emitted from IR source

r = the distance from the source to the heated object



# NOTES

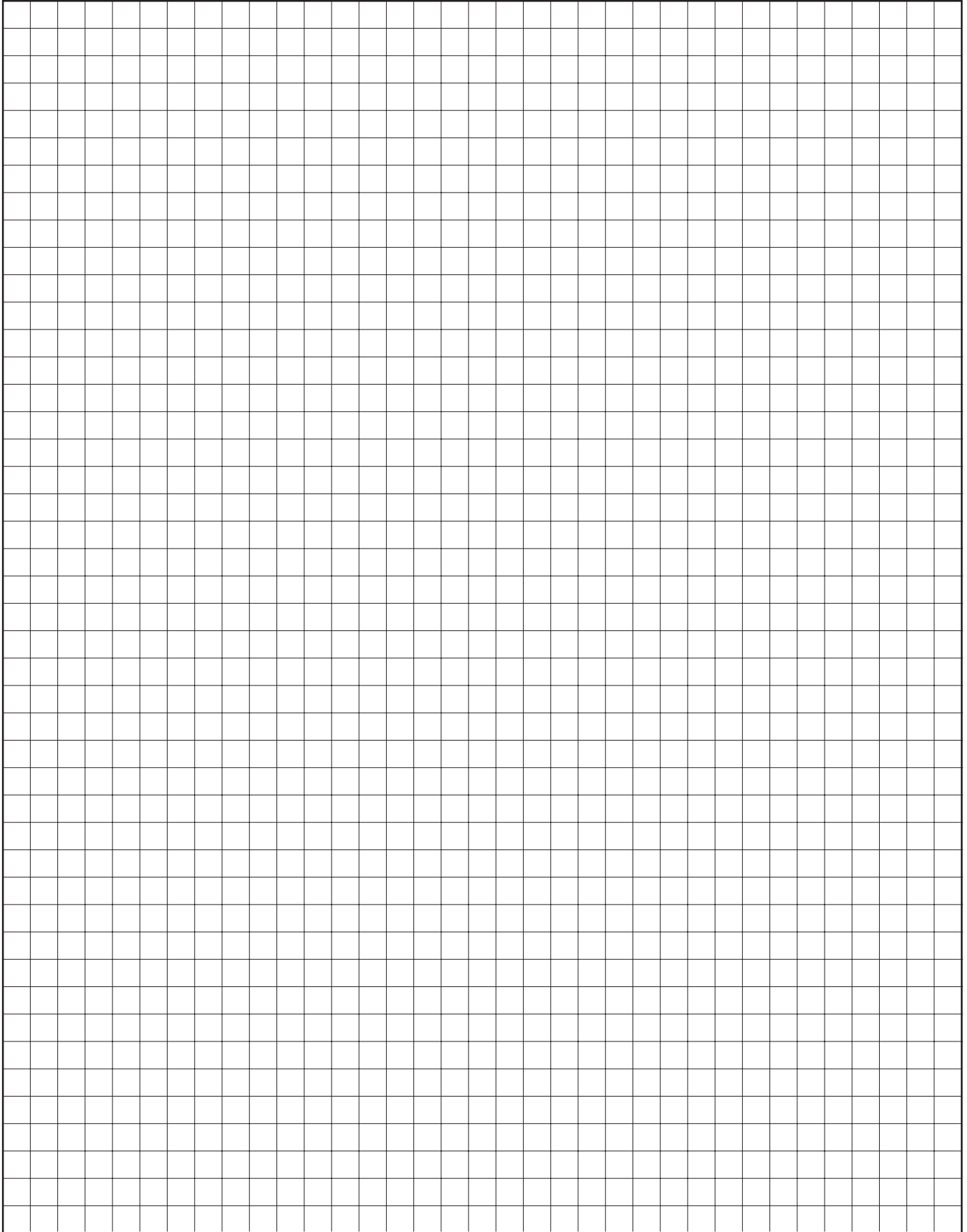



# NOTES

A large grid of graph paper for taking notes, consisting of 20 columns and 30 rows of small squares.



# HEATING SYSTEMS

As a leader in advanced heating and filtration solutions with facilities across North America, Thermon Heating Systems manufactures six of the top brands in industrial heating in addition to a comprehensive line of engineered industrial filtration products including:

## **Cata-Dyne™** Explosion-Proof Gas Catalytic Heaters

Cata-Dyne™ is the industry standard in infrared gas catalytic heaters, enclosures, pipeline systems and accessories. Customers across a wide range of industries rely on Cata-Dyne™ to supply them with safe, reliable, efficient and versatile infrared catalytic heating equipment for a variety of applications in both hazardous and non-hazardous environments.

Ruffneck™ is renowned for its rugged, reliable and versatile heavy-duty explosion-proof heaters, heating systems and heating accessories. Ruffneck™ has a long and proud history of supplying quality heating products for the harshest industrial environments to a worldwide customer base for over 30 years. Ruffneck™ is well-known in the industry for its “ship the heat in a week” policy, where 95% of all standard orders are shipped within one week of order placement.

## **Ruffneck™** Heaters for the Harshest Environments

## **3L Filters™** Engineered Filtration Systems

3L Filters™ has satisfied the most demanding industrial filtration requirements for over 40 years. A broad range of standard and custom products includes liquid filters, strainers, separators, pressure vessels, and engineered products and systems. 3L Filters™ has special expertise for nuclear, petrochemical, water treatment and environmental applications.

Caloritech™ electric heaters, heating elements and heating accessories are well-known in the industry for their quality, reliability, performance and versatility. In addition to standard “off the shelf” industrial heaters and heating systems components, Caloritech™ also offers engineered heating solutions custom designed, manufactured and tested to satisfy customer specifications. No matter what your application or environment, Caloritech™ has a solution to fit your heating needs.

## **Caloritech™** Engineered Electric Heat

## **Fastrax™** Track and Switch Heaters

Fastrax® has manufactured railroad track and switch heating since 1995. Fastrax® engineers complete heating packages for the rail industry. Fastrax® track and switch heaters are designed to provide the most efficient heat transfer on rail equipment and components for the coldest environments. In addition to heaters, Fastrax® manufactures fully automatic energy saving controls to complete the rail heating system.

Norseman™ is the most technologically advanced line of explosion-proof electric air heaters and heating accessories, including both forced air heaters and natural convection heaters, as well as unit heaters, panel heaters and thermostats. Norseman™ offers innovative, low maintenance solutions for a wide range of applications in a variety of industrial and commercial environments. Custom engineered heaters or heating systems are available for specialized applications.

## **Norseman™** Electric Explosion-Proof Heaters

Visit [www.thermon.com](http://www.thermon.com) for detailed product information.

**Edmonton, AB**  
1-800-661-8529  
780-466-3178  
F 780-468-5904

**Oakville, ON**  
1-800-410-3131  
905-829-4422  
F 905-829-4430

**Orillia, ON**  
1-877-325-3473  
705-325-3473  
F 705-325-2106

**Houston, TX**  
1-855-219-2101  
281-506-2310  
F 281-506-2316

**Denver, CO**  
1-855-244-3128  
303-979-7339  
F 303-979-7350