

PTG series

Smart Pressure Transmitter

Model PTG71 / PTG72

OVERVIEW

The Smart Pressure Transmitter model PTG is a high-performance, highly reliable gauge pressure transmitter. Based on Azbil Corporation's proven Smart Transmitter technologies, the model PTG offers improved performance and reliability with size, weight and cost advantages. An optional, built-in digital indicator allows the pressure transmitter to be used in a wide variety of applications. The model PTG can also enable two-way communications between HART 375 communicator, and, via DE protocol, a TDCS3000 or 3000X and a database, thus facilitating self-diagnosis, range resetting, and automatic zero adjustment operations.

FEATURES

Compact and lightweight

- Approx. 0.9 kg (Screw connection type)

Broad range setting

- Range from -100 kPa to +50 MPa.
- Span from 2.0 kPa to 50 MPa.

Note) Screw connection type. Covered with five ranges.

Remote communication

Any range can be set using the Smart communicator or the HART communicator (available separately).

This further increases range flexibility and keeps inventory down.

Built-in digital indicator

The built-in digital indicator option effectively checks output on site.

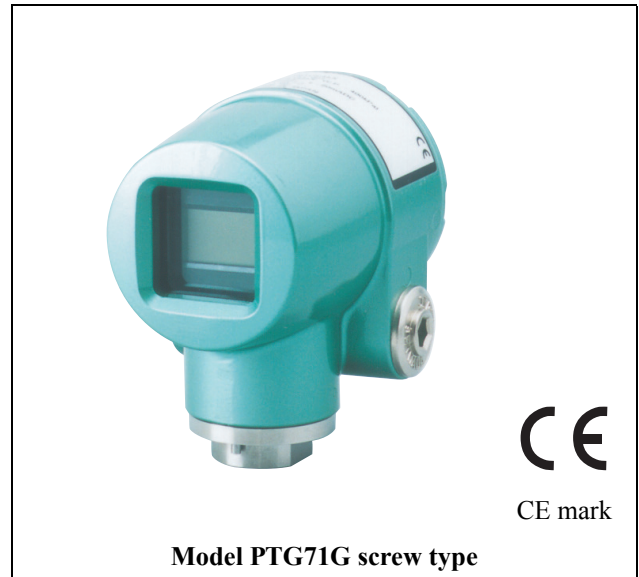

Model PTG71G screw type

Type of protection

- Water and dust proof for IEC IP67
- FM Explosionproof
- FM Dust-ignition-proof
- FM Intrinsically safe
- KOSHA Flameproof
- NEPSI Flameproof
- NEPSI Dust ignition-proof
- ATEX Flameproof

China RoHS

This device is used in the Oil & Gas, Petrochemical, Chemical, Pulp & Paper, Food & Beverage, Machinery, Steel/Metal & Mining, and Automobile industries and therefore does not fall under the China RoHS Legislation.

If this device is used in semiconductor manufacturing equipment, labeling on the device and documents for the China RoHS may be required. If such documents are required, consult an Azbil Corp. representative.

External views of the PTG series



*Model PTG7_G
(Screw type)*



*Model PTG7_B
(Flush diaphragm type)*



*Model PTG7_F
(Flange type)*



*Model PTG7_S
(Ferrule clamp type)*



*Model PTG7_S
(Ferrule cap nut type)*



*Model PTG7_K
(Ferrule clamp type
with cooling tower)*



*Model PTG7_K
(Ferrule cap nut type
with cooling tower)*



*Model PTG7_T
(Remote seal with ferrule clamp type)*



*Model PTG7_T
(Remote seal with ferrule cap nut type)*

COMMON SPECIFICATIONS

Type of protection

JIS C0920 watertight, NEMA 3 and 4X, IEC IP67

FM Explosionproof approval

Explosionproof for Class I, Division 1, Groups A, B, C and D, T4, ambient temperature = 60°C

Dust-ignition for Class II and III, Division 1, Groups E, F and G, T6 ambient temperature = 60°C, Type 4X

FM Intrinsically safe approval

Intrinsically safe for Class I, II, III, Division1, Group A, B, C, D, E, F, G

T4 / Class I, Zone 0, AEx ia IIC T4

KOSHA Flameproof approval

Ex d IIC T4

NEPSI Flameproof approval

Ex d IIC T4

Ambient temperature: -25°C to +60°C

Temperature of wetted part: -25°C to +130°C

Ex d IIC T5

Ambient temperature: -25°C to +60°C

Temperature of wetted part: -40°C to +95°C

Ex d IIC T6

Ambient temperature: -25°C to +40°C

Temperature of wetted part: -40°C to +80°C

NEPSI Dust ignition-proof

DIP DP T11

ATEX Flameproof approval

CE 0344



II 2 G EEx d IIC T4 MAX. AMBIENT
TEMP.: +60°C

PTB 02 ATEX 1117

IP67

Supply voltage and load resistance

Refer to Figure 1.

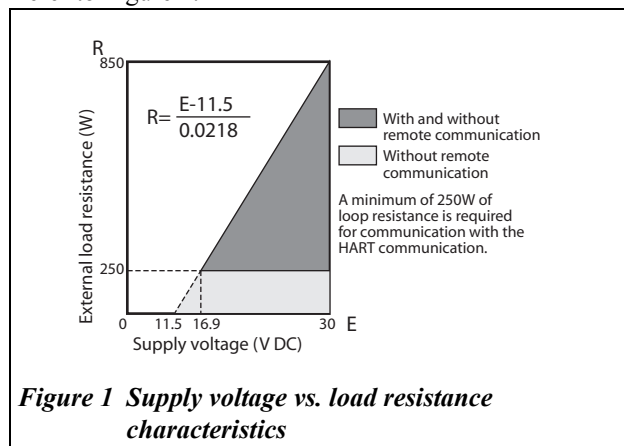

Power supply and voltage effect

0.005% F.S./V

Output / Communication

Model PTG71

- Analog output (4 to 20 mA DC) with SFN communication

Model PTG72

- Analog output (4 to 20 mA DC) with HART protocol
- DE output with CommStaff communication

Response speed

Approx. 400 ms

Vibration Tolerance

Less than 100 Hz : 2 G

100 to 2000 Hz : 1 G

Zero adjustment

Internal zero adjustment function

CE conformity

- EN50081-2-1993, Electromagnetic Compatibility- Generic Emission Standard, Part 2: Industrial Environment
- EN50082-2-1995, Electromagnetic Compatibility- Generic Immunity Standard, Part 2: Industrial Environment
- EN61010-1-1993, Safety requirements for electrical equipment, control and laboratory use, Part: General requirement

Finish

Baked acrylic paint, metallic green (Munsell 5G7/8)

Electrical connection

1/2 NPT internal thread

Mounting

- Direct mounting on a pipe (line mount)
- 2-inch pipe mounting
- Wall mounting

When mounting a PTG transmitter, consider its characteristics against vibration and overall vibration including piping.

Use an optional mounting bracket when mounting it onto 2-inch pipe or wall.

Optional specifications

Built-in indicating meter

The digital LCD indicator (optional) displays engineering units and can be set freely between -19999 and 19999 (4.5 digits).

Corrosion-proof finish

Corrosion-proof paint (Baked epoxy paint), fungus-proof finish

Remote communication function

Remote configuration function by using the smart communicator.

Oil free finish

Oil is removed from the wetted parts before shipment.

Oil and water free finish

Oil and water are removed from the wetted parts before shipment.

Electrolytic grinding (For ferrule type only)

The surface of the wetted parts is smoothed by electrolytic grinding.

Passive state finish (For ferrule type only)

The surface of the wetted parts is treated with a passive state finish to form a protective film to increase resistance to corrosion.

Test report

The test report indicates the results of appearance, I/O characteristics, insulation resistance, and breakdown voltage tests.

Material certificate

The material certificate shows the chemical composition, heat-treatment conditions, and mechanical properties of the materials used for the wetted parts. The transmitter can be easily zeroadjusted in the field with a flat-blade screwdriver.

Withstand pressure test

The withstand pressure test result sheet shows the results of a pressure resistance test (under water pressure for 10 minutes) performed on the wetted parts.

Strength calculation sheet

The strength calculation sheet indicates the strength of the meter body cover, flanges, bolts, etc.

Traceability certificate

This certificate consists of three parts: the transmitter's measurement control system configuration diagram, a calibration certificate, and a test report.

Mounting bracket

Bracket for 2-inch pipe or wall mounting (For thread connection type and ferrule remote sealed type)

Withstand pressure and air tight test (for general purposes)

The withstand pressure and air tight test result sheet shows the results of a pressure resistance test (under water pressure for 10 minutes) and a gas-tightness test (using N₂ gas for 10 minutes) performed on the wetted parts.

Working range of negative pressure

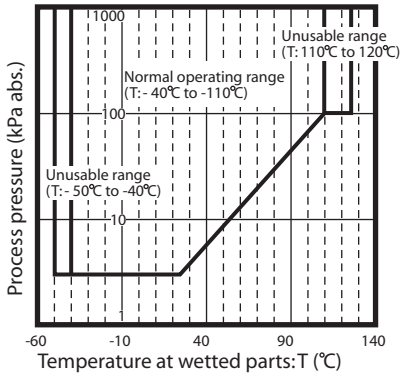

Figure 2 Minimum working pressure for model PTG_G

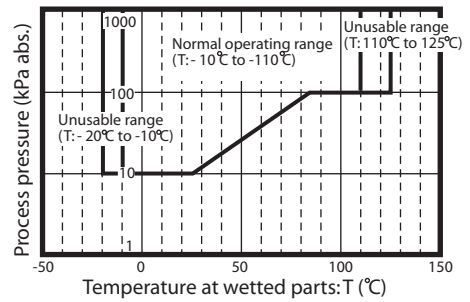

Figure 3 Minimum working pressure for combination of model PTG_S or model PTG_T or model PTG_B or PTG_F and propylene glycol.

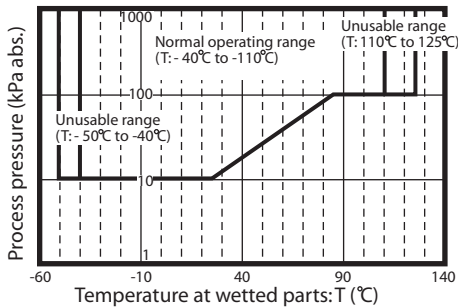

Figure 4 Minimum working pressure for combination of model PTG_B or model PTG_F and silicone oil.

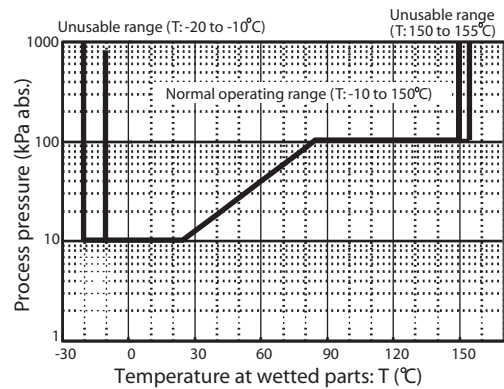

Figure 5 Minimum working pressure for model PTG_K.

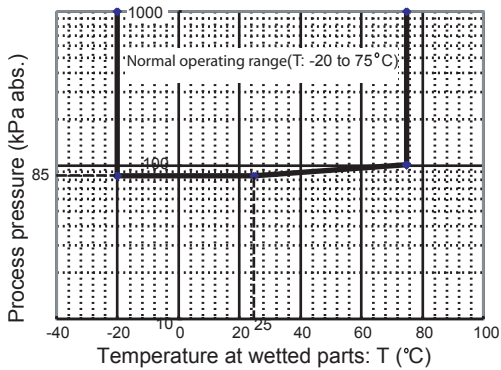
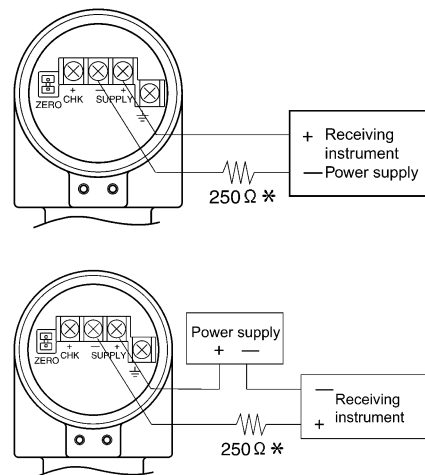

Figure 6 Minimum working pressure for combination of model PTG_G and fluorine oil.



Note) *A minimum of 250 Ω of loop resistance is required for communication with the HART Communicator.

Transmitter handling notes

To get the most from the performance this transmitter can offer, please use it properly noting the points mentioned below. Before using it, please read the Instruction Manual.

Transmitter installation notes

WARNING

- When installing the transmitter, ensure that gaskets do not protrude from connecting points into the process (such as adapter flange connection points and connecting pipes and flanges). Gasket protrusion may result in leaks and output errors.
- Do not use the transmitter outside its defined pressure, temperature, and connection specifications. A serious accident may otherwise occur due to damage and leaks.
- When performing wiring work in explosion-proof areas, follow the work method specified in the explosion-proof guidelines.

CAUTION

- After installing the transmitter, do not stand on it. Using it as a foothold could cause it to collapse and cause physical injury.
- Be careful not to hit the glass indicator with tools etc. This could break the glass and cause injury.
- The transmitter is heavy. Wear safety shoes and take care when installing it.
- Impact to transmitter can damage sensor module.

Wiring notes

WARNING

- To avoid shocks, do not perform electrical wiring work with wet hands or with live wires.

CAUTION

- Do wiring work properly in conformance with the specifications. Wiring mistakes may result in malfunction or irreparable damage to the instrument.
- Use a power supply that conforms to the specifications. Use of an improper power supply may result in malfunction or irreparable damage to the instrument.

Handling precautions for HART-specification devices

- "If you need to operate with a secondary host (HART communicator, etc.), set the communication interval of the primary host (DCS, device management system) to 8 seconds or more, or suspend communication from the primary host. If the primary host repeats HART communication within 8 seconds, the request from the secondary host may not be received (communication may not be possible).
- "If electrical noise in the environment prevents HART communications with the host, take countermeasures such as separating the signal cables from the source of the noise, improving the grounding, changing to shielded signal cables, etc. Even if noise interferes with HART communications, the 4-20 mA analog signal will be unaffected and can be used for control.
- "If this product is being operated in multidrop mode, there is a limit to the number of devices that can be used. If you are using multidrop mode, please consult with us.

Index of detailed specifications for process connection types

Process connection	Process connection style	Measurement span	Reference page
Screw type PTG_G	G3/8 external thread G1/2 external thread Rc3/8 internal thread Rc1/2 internal thread 1/2NPT internal thread M20 × 1.5 external	2.0 to 100 kPa {0.021 to 1.019 kgf/cm ² } 40 to 400 kPa {0.408 to 4.07 kgf/cm ² } 0.2 to 2 MPa {2.04 to 20.3 kgf/cm ² } 1 to 10 MPa {10.20 to 101.9 kgf/cm ² }	8 to 14
	Rc1/4 internal thread G1/2 external thread 1/4NPT internal thread M20 × 1.5 external thread	5 to 50 Mpa {51.0 to 509 kgf/cm ² }	
Flush diaphragm type PTG_B	G2-inch external thread	2.0 to 100 kPa {0.021 to 1.019 kgf/cm ² } 40 to 400 kPa {0.408 to 4.07 kgf/cm ² } 0.2 to 2 MPa {2.04 to 20.3 kgf/cm ² } 1 to 10 MPa {10.20 to 101.9 kgf/cm ² }	15 to 17
	G1/2-inch external thread	0.2 to 2 MPa {2.04 to 20.3 kgf/cm ² } 1 to 10 MPa {10.20 to 101.9 kgf/cm ² }	
Flange type PTG_F	JIS10K 50 mm JIS30K 50 mm JIS20K 25 mm JIS10K 15 mm JIS20K 15 mm JIS30K 15 mm	2.0 to 100 kPa {0.021 to 1.019 kgf/cm ² } 40 to 400 kPa {0.408 to 4.07 kgf/cm ² } 0.2 to 2 MPa {2.04 to 20.3 kgf/cm ² } 1 to 10 MPa {10.20 to 101.9 kgf/cm ² }	18 to 22
Ferrule type (Direct mount) PTG_S	IDF 2S clamp IDF 1.5S clamp IDF 1S clamp	2.0 to 100 kPa {0.021 to 1.019 kgf/cm ² } 40 to 400 kPa {0.408 to 4.07 kgf/cm ² } 0.2 to 2 MPa {2.04 to 20.3 kgf/cm ² }	23 to 25
	IDF 2S cap nut IDF 1.5S cap nut	2.0 to 100 kPa {0.021 to 1.019 kgf/cm ² } 40 to 400 kPa {0.408 to 4.07 kgf/cm ² } 0.2 to 2 MPa {2.04 to 20.3 kgf/cm ² }	26 to 28
Ferrule type with cool- ing tower PTG_K	IDF 2S clamp IDF 1.5S clamp	2.0 to 100 kPa {0.021 to 1.019 kgf/cm ² } 40 to 400 kPa {0.408 to 4.07 kgf/cm ² } 0.2 to 2 MPa {2.04 to 20.3 kgf/cm ² }	29 to 31
	IDF 1S clamp	40 to 400 kPa {0.408 to 4.07 kgf/cm ² } 0.2 to 2 MPa {2.04 to 20.3 kgf/cm ² }	
	IDF 2S cap nut IDF 1.5S cap nut	2.0 to 100 kPa {0.021 to 1.019 kgf/cm ² } 40 to 400 kPa {0.408 to 4.07 kgf/cm ² } 0.2 to 2 MPa {2.04 to 20.3 kgf/cm ² }	32 to 34
Remote seal with fer- rule type (Capillary 1, 3, 5 m) PTG_T	IDF 2S clamp	2.0 to 100 kPa {0.021 to 1.019 kgf/cm ² } 40 to 400 kPa {0.408 to 4.07 kgf/cm ² } 0.2 to 2 MPa {2.04 to 20.3 kgf/cm ² }	35 to 37
	IDF 1.5S clamp	40 to 400 kPa {0.408 to 4.07 kgf/cm ² } 0.2 to 2 MPa {2.04 to 20.3 kgf/cm ² }	
	IDF 2S cap nut	2.0 to 100 kPa {0.021 to 1.019 kgf/cm ² } 40 to 400 kPa {0.408 to 4.07 kgf/cm ² } 0.2 to 2 MPa {2.04 to 20.3 kgf/cm ² }	38 to 40
	IDF 1.5S cap nut	40 to 400 kPa {0.408 to 4.07 kgf/cm ² } 0.2 to 2 MPa {2.04 to 20.3 kgf/cm ² }	

Screw type



Measuring span / Setting range / Max. working pressure

Model no.	Measuring span	Setting Range	Max. Working Pressure	Process Connection
PTG7_G - _3	2.0 to 100 kPa	-100 to +100 kPa	200 kPa	Rc3/8 internal thread, Rc1/2 internal thread, G3/8 external thread, G1/2 external thread, 1/2NPT internal thread, M20 x 1.5 external thread
PTG7_G - _4	40 to 400 kPa	-100 to +400 kPa	800 kPa	
PTG7_G - _5	0.2 to 2 MPa	-0.1 to +2 MPa	4 MPa	
PTG7_G - _6	1 to 10 MPa	-0.1 to +10 MPa	20 MPa	
PTG7_G - _7	5 to 50 MPa	-0.1 to +50 MPa	75 MPa*	

Note) * 62.5 MPa for explosion-proof type

Accuracy / Temperature effect

Model PTG7_G- _3

Accuracy *1	± 0.2% F.S. (100 kPa > X > 20 kPa) ± (0.2×20 / X)% F.S. (20 kPa > X > 2 kPa)
-------------	---

Zero temperature effect per 30°C *1	± (0.5×40 / X + 0.35)%
-------------------------------------	------------------------

Model PTG7_G- _4

Accuracy *1	± 0.2% F.S. (400 kPa > X > 80 kPa) ± (0.2×80 / X)% F.S. (80 kPa > X > 40 kPa)
-------------	--

Zero temperature effect per 30°C *1	± (0.4 × 80 / X + 0.35)%
-------------------------------------	--------------------------

Model PTG7_G- _5

Accuracy *1	± 0.2% F.S. (2.0 MPa > X > 0.4 MPa) ± (0.2 × 0.4 / X)%F.S. (0.4 MPa > X > 0.2 MPa)
-------------	---

Zero temperature effect per 30°C *1	± (0.4 × 0.4 / X + 0.35)%
-------------------------------------	---------------------------

Model PTG7_G- _6

Accuracy *1	± 0.2% F.S. (10 MPa > X > 2.0 MPa) ± (0.2 × 2.0/X)%F.S. (2.0 MPa > X > 5.0 MPa)
-------------	--

Zero temperature effect per 30°C *1	± (0.4 × 2.0 / X + 0.35)%
-------------------------------------	---------------------------

Model PTG7_G- _7

Accuracy *1	± 0.2% F.S. (50 MPa > X > 10 MPa) ± (0.2 × 10.0 / X)% F.S. (10 MPa > X > 5.0 MPa)
-------------	--

Zero temperature effect per 30°C *1	± (0.4 × 10.0 / X + 0.35)%
-------------------------------------	----------------------------

Note) *1: Within a range of URV ≥ 0 and LRV ≥ 0

Ambient temperature limits

Normal operating range

Water and dust proof	FM Explosion proof FM Intrinsically safe KOSHA Flameproof NEPSI Flameproof (Ex d II CT4, 5) ATEX Flameproof	NEPSI Flameproof (Ex d II CT6)
-20 to +70°C	-20 to +60°C	-20 to +40°C

Transportation and storage conditions

-30 to +80°C

Temperature range of wetted parts

Fill fluid	Water and dust proof	FM Explosion proof FM Intrinsically safe KOSHA Flameproof NEPSI Flameproof (Ex d II CT4) ATEX Flameproof	NEPSI Flameproof (Ex d II CT5)	NEPSI Flameproof (Ex d II CT6)
Silicone oil	-40 to +110°C	-20 to +110°C	-20 to +95°C	-20 to +80°C
Fluorine oil	-25 to +75°C			

Ambient humidity limits

5 to 100% RH

Materials

Fill fluid

- Silicone oil (for general purpose models)
- Fluorine oil (for oxygen and chlorine models)

Wetted parts

Diaphragm

SUS316L

Others

SUS316

Case

Aluminum alloy

Weight

Approx. 0.9 kg

Process connection

- G1/2 external thread
- G3/8 external thread
- Rc1/4 external thread
- Rc1/2 external thread
- Rc3/8 external thread
- 1/4 NPT internal thread
- 1/2 NPT internal thread
- M20 x 1.5 external thread

For other specification, please refer to COMMON SPECIFICATIONS.

MODEL SELECTION**Smart Pressure Transmitter model PTG7XG**

Process connection: Screw type

Measuring span: 2.0 to 100 kPa, 40 to 400 kPa, 0.2 to 2 MPa, 1 to 10 MPa, 5 to 50 MPa

Model number structure: Basic model number - selection - Option1 - Option2

Basic model number							
Product description	Gauge pressure transmitter: Screw connection type with SFN communication	PTG71G					
	Gauge pressure transmitter: Screw connection type with HART communication	PTG72G					
		-					
Type of protection	Water and dust proof: IEC IP67 Electrical connection: 1/2 NPT		N				
	FM Explosionproof and dust-ignition Electrical connection: 1/2 NPT		D				
	FM Intrinsically safe Electrical connection: 1/2 NPT		E				
	KOSHA Flameproof Electrical connection: 1/2 NPT		K				
	NEPSI Flameproof and dust-ignition Electrical connection: 1/2 NPT		L				
	ATEX Flameproof Electrical connection: M20 × 1.5 *4		V				
	Measuring span	2.0 to 100 kPa (0.021 to 1.019 kgf/cm ²)			3		
40 to 400 kPa (0.408 to 4.07 kgf/cm ²)				4			
0.2 to 2 MPa (2.04 to 20.3 kgf/cm ²)				5			
1 to 10 MPa (10.20 to 101.9 kgf/cm ²)				6			
5 to 50 MPa (51.0 to 509 kgf/cm ²) *1				7			
Material: Diaphragm / wetted parts other than diaphragm / fill fluid	SUS316L / SUS316 / Silicone oil				B1		
	SUS316L / SUS316 / Fluorine oil *2				B2		
Process connection	G½ external thread					G4	
	G3/8 external thread (Not applicable for measuring span code "7")					G3	
	Rc1/4 internal thread (Applicable only for measuring span code "7")					C2	
	Rc½ internal thread (Not applicable for measuring span code "7")					C4	
	Rc3/8 internal thread (Not applicable for measuring span code "7")					C3	
	1/2NPT external thread (Not applicable for measuring span code "7")					M4	
	1/4NPT internal thread (Applicable only for measuring span code "7")					N2	
	½NPT internal thread (Not applicable for measuring span code "7")					N4	
	M20 × 1.5 external thread					PH	
Option 1							-
No option							X
Built-in digital indicator							M
Corrosion-proof finish							B
Wetted part finish	Oil free finish						G
	Water and oil free finish						H
Option 2							-
No option							X
Test report							1
Material certificate							2
Withstand pressure test							4
Strength calculation sheet (JIS)							5
Traceability certificate							6
Non SI unit							F
Mounting bracket							H
Electrical connection M20 × 1.5 adapter *3							T

Note) *1 Not applicable for ATEX Flame proof "V" in the Type of protection.

*2 The oil free finish or the water and oil free finish in the Option1 must be selected.

*3 Applicable only for water and dust proof "N" and FM intrinsically safe "E" in the Type of protection.

*4 "Built-in digital indicator" in the Option 1 must be selected.

DIMENSIONS

[mm]

Materials of construction

KEY No.	Description	Materials
1	Case	Aluminum alloy
2	Body	SUS 316 (Diaphragm SUS 316L)

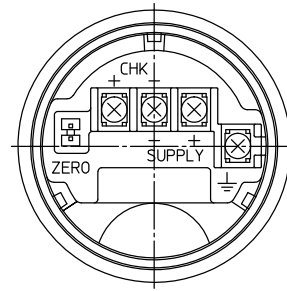

Terminal Connection
(M4 Screw)

See Table 1

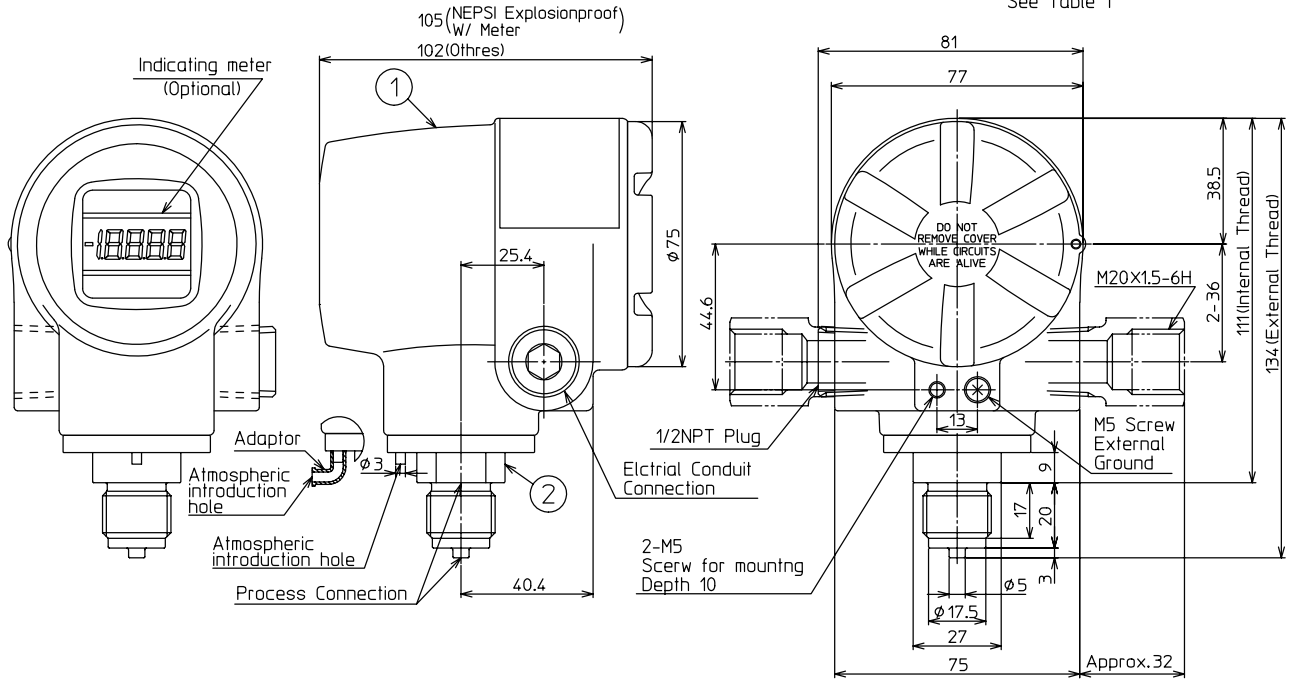
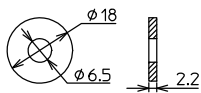

Table1 Terminal

Symbol	Terminal
SUPPLY +, SUPPLY -	Power supply and output signal
CHK +, CHK -	Check meter
⊥	Ground
ZERO	ZERO Adjuster

Note 1. A ring-shaped gasket as in below drawing is included for external thread connections.
Material :teflon (PTFE)



Process connection : G1/2 External
: 1/2NPT, 1/4NPT, Rc1/2, Rc1/4 internal
: M20x1.5 External

[mm]

Material of Construction

KEY No.	Description	Material
1	Case	Aluminum Alloy
2	Body	SUS 316 (Diaphragm SUS 316L)

Terminal Connection
(M4 Screw) See Table 1

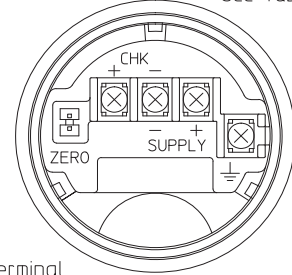
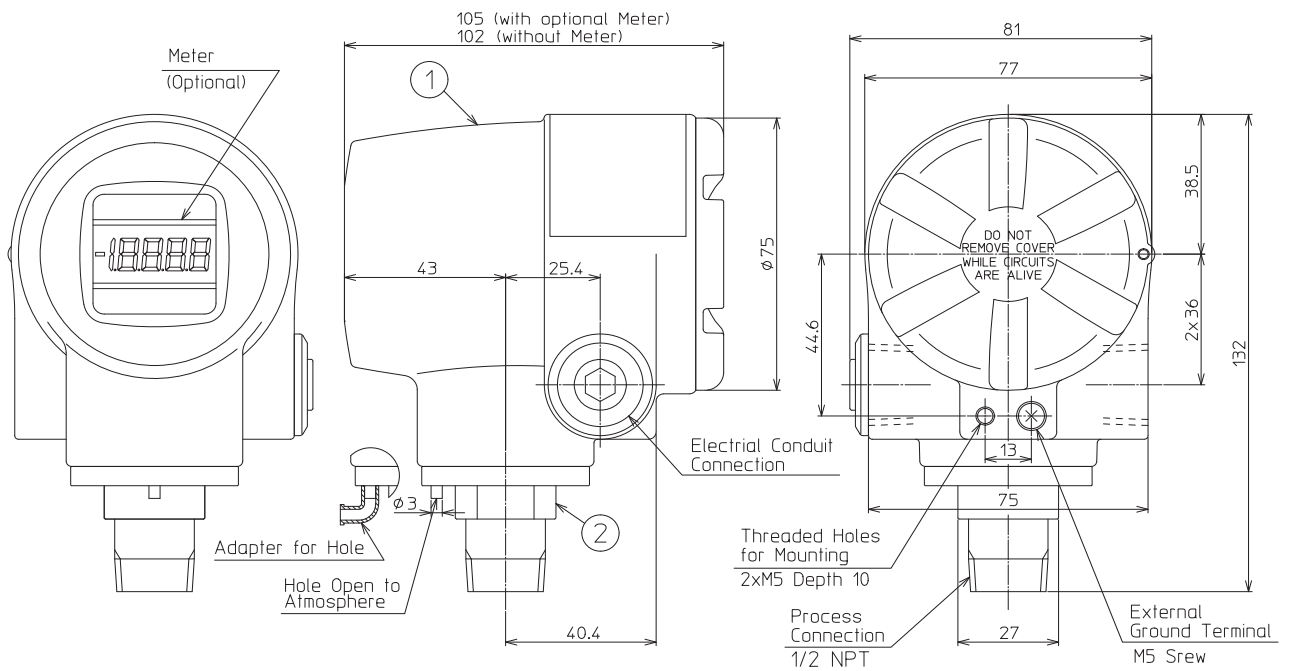

Table1 Terminal

Symbol	Terminal
SUPPLY +, SUPPLY -	Power Supply and Output Signal
CHK+, CHK-	Check Meter
⏏	Ground
ZERO	Zero Adjustment



Process connection : 1/2 NPT External

[mm]

Materials of construction

KEY No.	Description	Materials
1	Case	Aluminum alloy
2	Body	SUS 316 (Diaphragm SUS 316L)
3	Joint	SUS 316

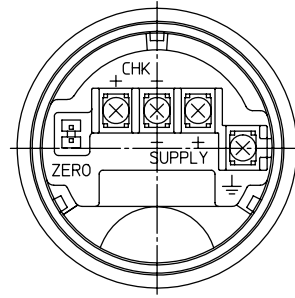

Terminal Connection
(M4 Screw)

See Table 1

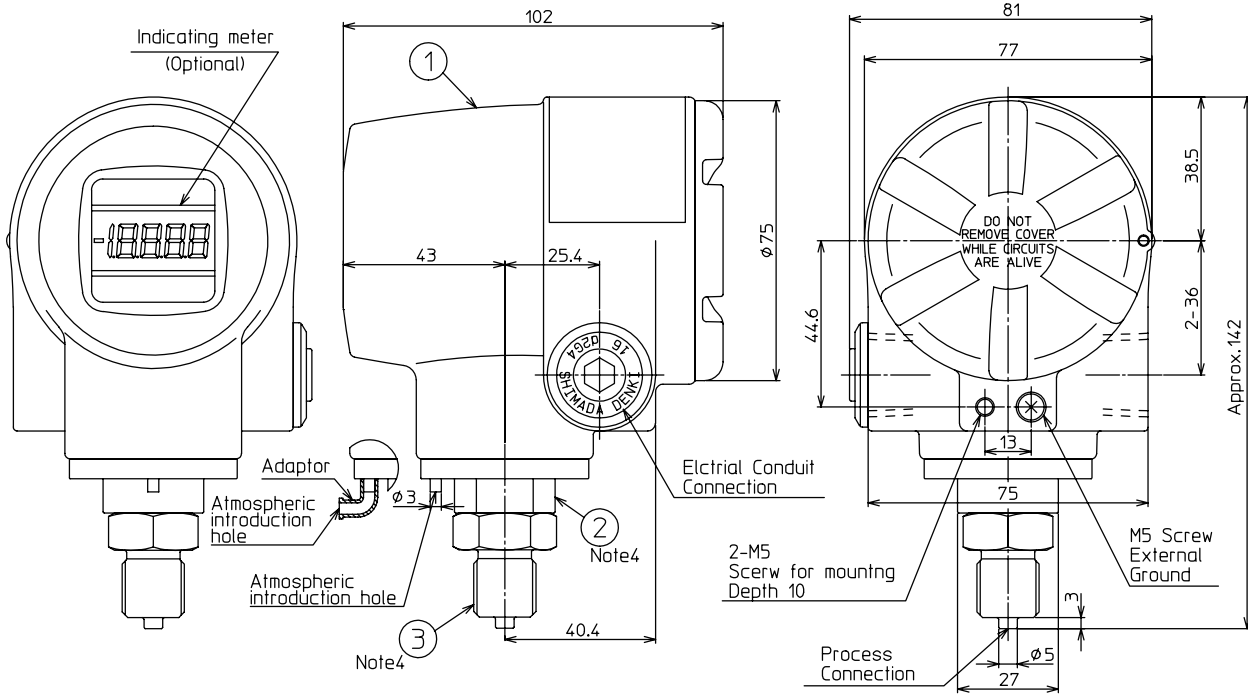

Note 1. A ring-shaped gasket as in below drawing is included for external thread connections.
Material :teflon (PTFE)

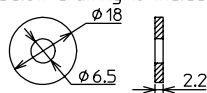

2. Do not tighten or loosen ③ from ②.
Grab only ③ when connecting or removing from piping.

Table1 Terminal

Symbol	Terminal
SUPPLY +, SUPPLY -	Power supply and output signal
CHK+, CHK-	Check meter
⏚	Ground
ZERO	ZERO Adjuster

Process connection :G3/8 External

[mm]

Materials of construction

KEY No.	Description	Materials
1	Case	Aluminum alloy
2	Body	SUS 316 (Diaphragm SUS 316L)
3	Joint	SUS 316

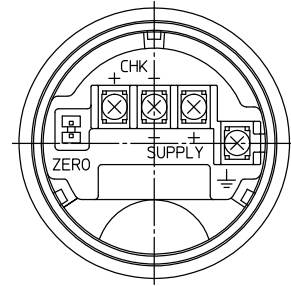

Terminal Connection
(M4 Screw)

See Table 1

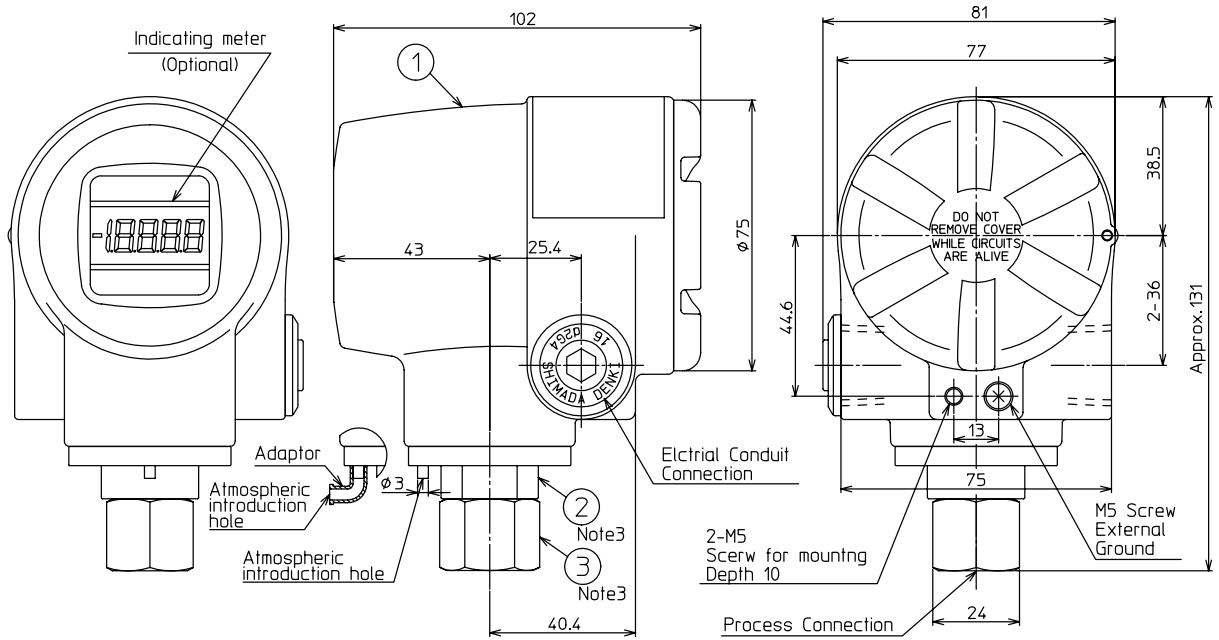

Note 1. Do not tighten or loosen ③ from ②.
Grab only ③ when connecting or removing from piping.

Table1 Terminal

Symbol	Terminal
SUPPLY +, SUPPLY -	Power supply and output signal
CHK+, CHK-	Check meter
⏏	Ground
ZERO	ZERO Adjuster

Process connection : Rc3/8 Internal

[mm]

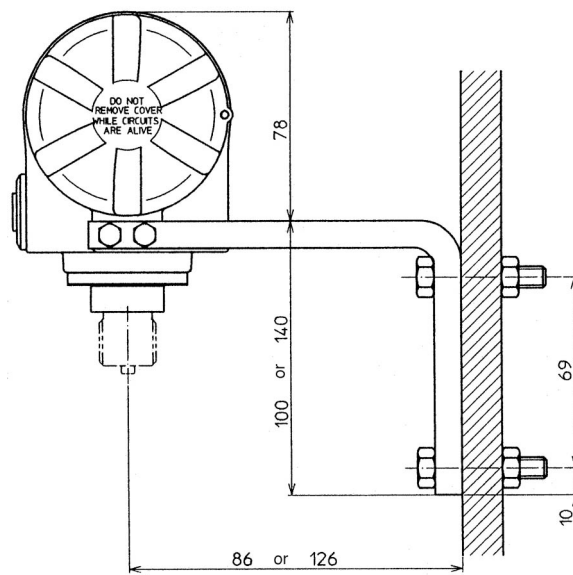
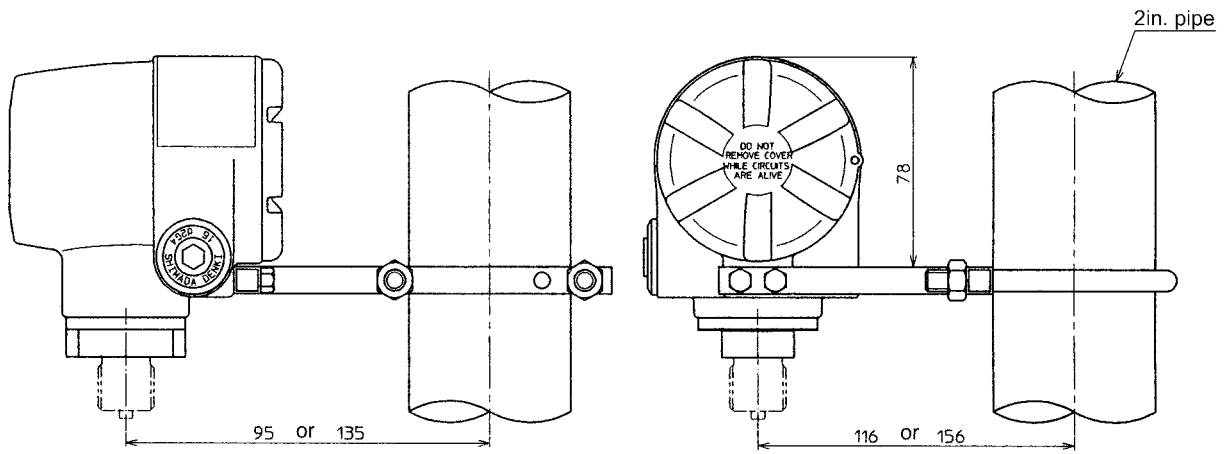

Flush diaphragm type

(G2 inch external, G1/2 inch external / flush diaphragm)



Measuring span / Setting range / Max. working pressure

Model Number	Measuring span	Setting Range	Max. Working Pressure	Process Connection
PTG7_B - _3	2.0 to 100 kPa	-100 to +100 kPa	200 kPa	G2 external thread
PTG7_B - _4	40 to 400 kPa	-100 to +400 kPa	800 kPa	
PTG7_B - _5	0.2 to 2 MPa	-0.1 to +2 MPa	4 MPa	G2 external thread
PTG7_B - _6	1 to 10 MPa	-0.1 to +10 MPa	20 MPa	G1/2 external thread

Accuracy / Temperature effect

Model PTG7_B- _3

Accuracy *1	± 0.5% F.S. (100 kPa ≥ X ≥ 20 kPa) ± (0.5 × 20 / X)% F.S. (20 kPa ≥ X ≥ 2.0 kPa)	
-------------	---	--

Zero temperature effect per 30°C *1	G2 external thread	± (4.7 × 40 / X + 0.35)%
-------------------------------------	--------------------	--------------------------

Model PTG7_B- _4

Accuracy *1	± 0.5% F.S. (400 kPa ≥ X ≥ 80 kPa) ± (0.5 × 80 / X)% F.S. (80 kPa ≥ X ≥ 40 kPa)	
-------------	--	--

Zero temperature effect per 30°C *1	G2 external thread	± (2.5 × 80 / X + 0.35)%
-------------------------------------	--------------------	--------------------------

Model PTG7_B- _5

Accuracy *1	± 0.5% F.S. (2 MPa ≥ X ≥ 0.4 MPa) ± (0.5 × 0.4 / X)% F.S. (0.4 MPa ≥ X ≥ 0.2 MPa)	
-------------	--	--

Zero temperature effect per 30°C *1	G2 external thread	± (0.82 × 0.4 / X + 0.35)%
	G1/2 external thread	± (10.8 × 0.4 / X + 0.35)%

Model PTG7_B- _6

Accuracy *1	± 0.5% F.S. (10.0 MPa ≥ X ≥ 2.0 MPa) ± (0.5 × 2.0 / X)% F.S. (2.0 MPa ≥ X ≥ 1.0 MPa)	
-------------	---	--

Zero temperature effect per 30°C *1	G2 external thread	± (0.49 × 2.0 / X + 0.35)%
	G1/2 external thread	± (2.48 × 2.0 / X + 0.35)%

Note) *1: Within a range of URV ≥ 0 and LRV ≥ 0

Ambient temperature limits

Normal operating range

	Water and dust proof FM Explosion proof FM Intrinsically safe KOSHA Flameproof NEPSI Flameproof (Ex d II CT4,5) ATEX Flameproof	NEPSI Flameproof (Ex d IICT6)
G2 external thread	-10 to +60°C	-10 to +40°C
G1/2 external thread	-10 to +50°C	-10 to +40°C

Transportation and storage temperature

-20 to +60°C

Temperature ranges of wetted parts

	Water and dust proof FM Explosionproof FM Intrinsically safe KOSHA Flameproof NEPSI Flameproof (Ex d II CT4) ATEX Flameproof	NEPSI Flameproof (Ex d IICT5)	NEPSI Flameproof (Ex d IICT6)
G2 external thread	-10 to +110°C	-10 to +95°C	-10 to +80°C
G1/2 external thread	-10 to +85°C	-10 to +85°C	-10 to +80°C

Ambient humidity limits

5 to 100% RH

Materials

Fill fluid

- Silicone oil
- Propylene glycol

Wetted parts

Diaphragm
SUS316L

Others
SUS316

Case

Aluminum alloy

Weight

- G2 inch external thread: Approx. 2.5 kg
- G1/2 inch external thread: Approx. 1.5 kg

Process connection

- G2 inch external thread
- G1/2 inch external thread

For other specification, please refer to COMMON SPECIFICATIONS.

MODEL SELECTION

Smart pressure transmitter model PTG7XB

Process connection: Flush diaphragm type (G2 inch external, G1/2 inch external / flush diaphragm)

Measuring span: 2.0 to 100 kPa, 40 to 400 kPa, 0.2 to 2 MPa, 1 to 10 MPa

Basic model number		Selection				Option1	Option2
		-				-	-
Product description	Gauge pressure transmitter: Screw connection type (flush) with SFN Communication	PTG71B					
	Gauge pressure transmitter: Screw connection type (flush) with HART communication	PTG72B					
		-					
Type of protection	Water and dust proof: IEC IP67 Electrical connection: 1/2NPT	N					
	FM Explosionproof and dust-ignition Electrical connection: 1/2NPT	D					
	FM Intrinsically safe Electrical connection: 1/2 NPT	E					
	KOSHA Flameproof Electrical connection: 1/2 NPT	K					
	NEPSI Flameproof and dust-ignition Electrical connection: 1/2 NPT	L					
	ATEX Flameproof Electrical connection: M20 × 1.5	V					
	Measuring span	2.0 to 100 kPa (0.021 to 1.019 kgf/cm ²) (Not applicable for process connection G1/2)	3				
40 to 400 kPa (0.408 to 4.07 kgf/cm ²) (Not applicable for process connection G1/2)		4					
0.2 to 2MPa (2.04 to 20.3 kgf/cm ²)		5					
1 to 10MPa (10.20 to 101.9 kgf/cm ²)		6					
Material: Diaphragm / wetted parts other than diaphragm /fill fluid	SUS316L/SUS316L/Silicone oil			CI			
	SUS316L/SUS316L/Propylene glycol			CB			
Process connection	G2 external thread				AGF		
	G½ external thread				AG4		
Option 1						-	
No option						X	
Built-in digital indicator						M	
Corrosion-proof finish						B	
Wetted part finish	Oil free finish					G	
	Water and oil free finish					H	
Option2						-	
No option							X
Test report							1
Material certificate							2
Withstand pressure test							4
Strength calculation sheet (JIS)							5
Traceability certificate							6
Non SI unit							F
Mounting bracket							H
Electrical connection: M20 × 1.5 adapter *1							T

Note) *1 Applicable only for water and dust proof “N” and FM intrinsically safe “E” in the Type of protection.

DIMENSIONS

[mm]

Materials of construction

KEY No.	Description	Materials
1	Case	Aluminum alloy
2	Body	SUS 316 (Diaphragm SUS 316L)
3	Wetted Part	SUS 316L

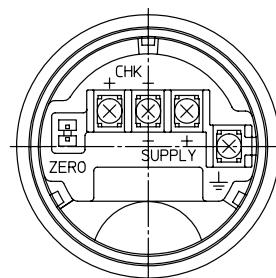

Terminal Connection

(M4 Screw)

See Table 2

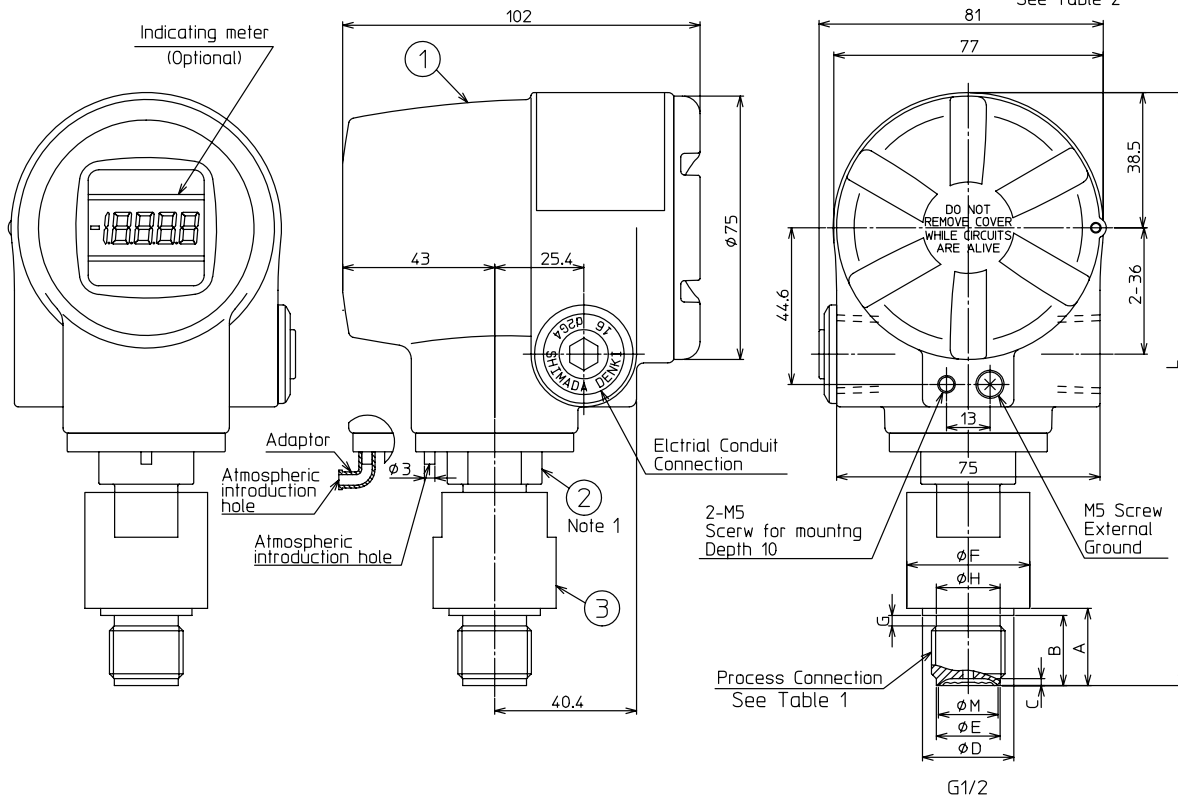
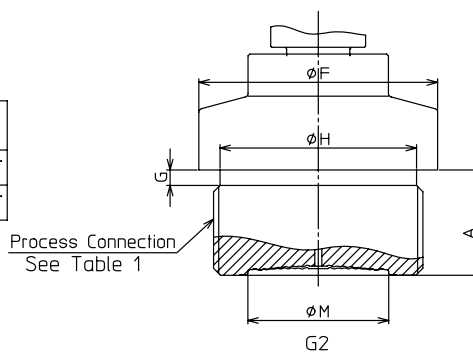

Table1

Code No.			Thread Type of Process Connection (G)	A	B	ØD	C	ØE	ØF	G	ØH	ØM	L
Fitting	Thread Type	Thread Size											
A	G	4	G 1/2 External	22	20	26	2	18.2	35	2.5	17.8	17	Approx. 172
		F	G 2 External	30	—	—	—	68	4.4	56	43	17	Approx. 180

Table2 Terminal

Symbol	Terminal
SUPPLY + SUPPLY -	Power supply and output signal
CHK+·CHK-	Check meter
⊥	Ground
ZERO	ZERO Adjuster



Note 1. Do not loosen, Loosening will lead to fill-fluid leakage.

Flange type

(1/2 inch, 1 inch, 2 inches)



Measuring Span / Setting Range / Max. Working Pressure

Model Number	Measuring span	Setting Range	Max. Working Pressure	Process Connection
PTG7_F - _3	2.0 to 100 kPa	-100 to +100 kPa	200 kPa	2 inches (50 mm), 1 inch (25 mm), 1/2 inch (15 mm)
PTG7_F - _4	40 to 400 kPa	-100 to +400 kPa	800 kPa	
PTG7_F - _5	0.2 to 2 MPa	-0.1 to +2 MPa	4 MPa or flange rating	
PTG7_F - _6	1 to 10 MPa	-0.1 to +10 MPa	20 MPa or flange rating	

Accuracy / Temperature effect

Model PTG7_F - _3

Accuracy *1	± 0.5% F.S. (100 kPa ≥ X ≥ 20 kPa) ± (0.5 × 2.0 / X)% F.S. (20 kPa > X > 2 kPa)
-------------	--

Zero temperature effect per 30°C *1	1 inches (25mm)	± (4.5 × 40 / X + 0.35)%
	2 inches (50 mm)	
	1/2 inch (15 mm)	

Model PTG7_F - _4

Accuracy *1	± 0.5% F.S. (400 kPa ≥ X ≥ 80 kPa) ± (0.5 × 80 / X)% F.S. (80 kPa ≥ X ≥ 40 kPa)
-------------	--

Zero temperature effect per 30°C *1	1 inches (25mm)	± (2.4 × 80 / X + 0.35)%
	2 inches (50 mm)	
	1/2 inch (15 mm)	

Model PTG7_F - _5

Accuracy *1	± 0.5% F.S. (2MPa ≥ X ≥ 0.4MPa) ± (0.5 × 0.4 / X)% F.S. (0.4MPa ≥ X ≥ 0.2MPa)
-------------	--

Zero temperature effect per 30°C *1	1 inches (25mm)	± (0.8 × 0.4 / X + 0.35)%
	2 inches (50 mm)	
	1/2 inch (15 mm)	

Model PTG7_F - _6

Accuracy *1	± 0.5% F.S. (10.0 MPa > X > 2.0 MPa) ± (0.5 × 2.0 / X)% F.S. (2.0 MPa > X > 1.0 MPa)
-------------	---

Zero temperature effect per 30°C *1	1 inches (25mm)	± (0.5 × 2.0 / X + 0.35)%
	2 inches (50 mm)	
	1/2 inch (15 mm)	

Note) *1: Within a range of URV ≥ 0 and LRV ≥ 0

Ambient temperature limits

Normal operating range

Fill fluid	Water and dust proof	FM Explosion proof FM Intrinsically safe KOSHA Flameproof NEPSI Flameproof (Ex d II CT4,5) ATEX Flameproof	NEPSI Flameproof (Ex d IICT6)
Silicone oil	-20 to +70°C	-20 to +60°C	-20 to +40°C
Propylene glycol	-10 to +70°C	-10 to +60°C	-10 to +40°C

Transportation and storage temperature

-30 to +80°C

Temperature ranges of wetted parts

Fill fluid	Water and dust proof	FM Explosion proof FM Intrinsically safe KOSHA Flameproof NEPSI Flameproof (Ex d II CT4) ATEX Flameproof	NEPSI Flameproof (Ex d IICT5)	NEPSI Flameproof (Ex d IICT6)
Silicone oil	-40 to +110°C	-20 to +110°C	-20 to +95°C	-20 to +80°C
Propylene glycol	-10 to +110°C	-10 to +110°C	-10 to +95°C	-10 to +80°C

150°C for 60 minutes during steam cleaning for water and dust proof model

Ambient humidity limits

5 to 100% RH

Materials

Fill fluid

- Silicone oil
- Propylene glycol

Wetted parts

Diaphragm

SUS316L

Others

SUS316

Flange parts

SUS304

Case

Aluminum alloy

Weight

JIS10K 50mm type : Approx. 4.2 kg

JIS10K 15mm type : Approx. 2 kg

Process connection

- JIS10K 15 mm, 50 mm
- JIS20K 15 mm, 25 mm
- JIS30K 15 mm, 50 mm

For other specification, please refer to COMMON SPECIFICATIONS.

MODEL SELECTION**Smart pressure transmitter model PTG7XF**

Process connection: Flange type

Measuring span: 2.0 to 100 kPa, 40 to 400 kPa, 0.2 to 2 MPa, 1 to 10 MPa

Model number structure: Basic model number - Selection - Option1 - Option2

Basic model number		Selection						Option1	Option2
Product description	Gauge pressure transmitter: Flange mount type with SFN communication	PTG71F							
	Gauge pressure transmitter: Flange mount type with HART communication	PTG72F							
		-							
Type of protection	Water and dust proof: IEC IP67 Electrical connection: 1/2NPT	N							
	FM Explosionproof and dust-ignition Electrical connection: 1/2NPT	D							
	FM Intrinsically safe Electrical connection: 1/2 NPT	E							
	KOSHA Flameproof Electrical connection: 1/2 NPT	K							
	NEPSI Flameproof and dust-ignition Electrical connection: 1/2 NPT	L							
	ATEX Flameproof Electrical connection: M20 × 1.5	V							
	Measuring span	2.0 to 100 kPa (0.021 to 1.019 kgf/cm ²)	3						
40 to 400 kPa (0.408 to 4.07 kgf/cm ²)		4							
0.2 to 2 MPa (2.04 to 20.3 kgf/cm ²)		5							
1 to 10 MPa (10.20 to 101.9 kgf/cm ²)		6							
Material Diaphragm / wetted parts other than dia- phragm/fill fluid	SUS316L/SUS316L/Silicone oil	C1							
	SUS316L/SUS316L/Propylene glycol	CB							
Flange standard/rating	JIS10K	A							
	JIS20K *1	C							
	JIS30K	D							
	ANSI 150	G							
	ANSI 300	H							
	ANSI 600	J							
Flange diameter	2 inches / 50 mm	3							
	1 inch / 25 mm *2	5							
	1/2 inch / 15 mm	7							
Flange material	SUS304					S			
Flange extension	None						X		
Option 1								-	
No option								X	
Built-in digital indicator								M	
Corrosion-proof finish								B	
Wetted parts finish	Oil free finish							G	
	Water and oil free finish							H	
Option2								-	
No option								X	
Test report								1	
Material certificate								2	
Withstand pressure test								4	
Strength calculation sheet (JIS)								5	
Traceability certificate								6	
Non SI unit								F	
Electrical connection:M20 × 1.5 adapter *3								T	

Note) *1 The 2 inches / 50 mm "code 3" in the Flange diameter can not be selected.

*2 Only applicable for the JIS20K "code C" in the Flange standard / rating.

*3 Applicable only for water and dust proof "N" and FM intrinsically safe "E" in the Type of protection.

DIMENSIONS

[mm]

Materials of construction

KEY No.	Description	Materials
1	Case	Aluminum alloy
2	Body	SUS 316
3	Wetted Part	See Spec. Code.

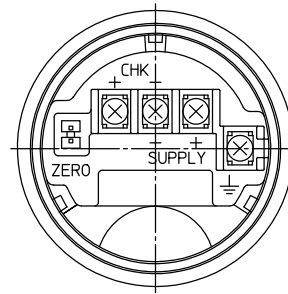

Terminal Connections
(M4 Screw)
See Table 1

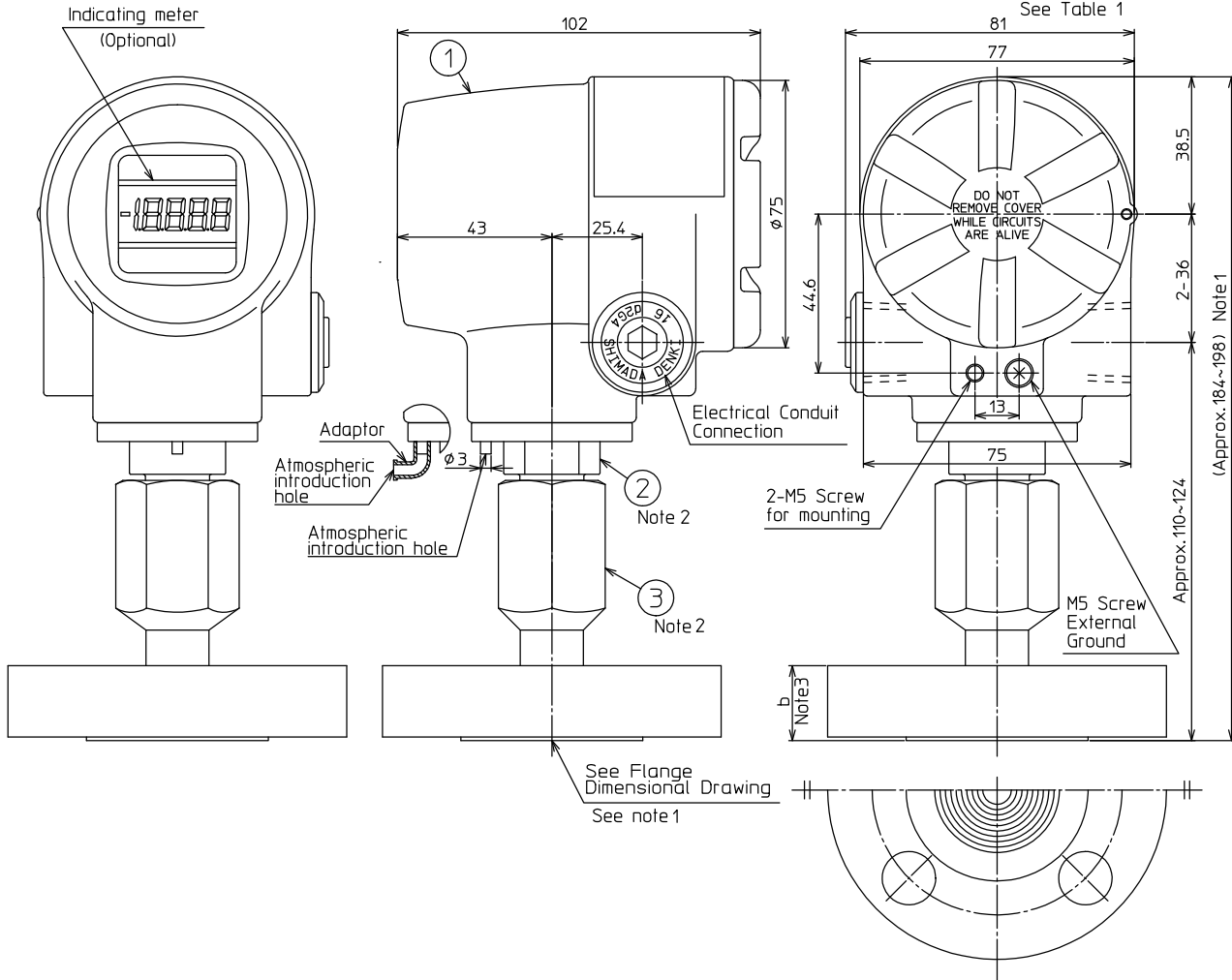

- Note 1. Total length will vary from 184 to 198 according to flange thickness b. See page18 for b value.
- 2. Do not loosen. Loosening will lead to fill-fluid leakage.
- 3. See Flange Dimensional Drawing See note 1

Table1 Terminal

Symbol	Terminal
SUPPLY +, SUPPLY -	Power supply and output signal
CHK+, CHK-	Check meter
⏚	Ground
ZERO	ZERO Adjuster

[mm]

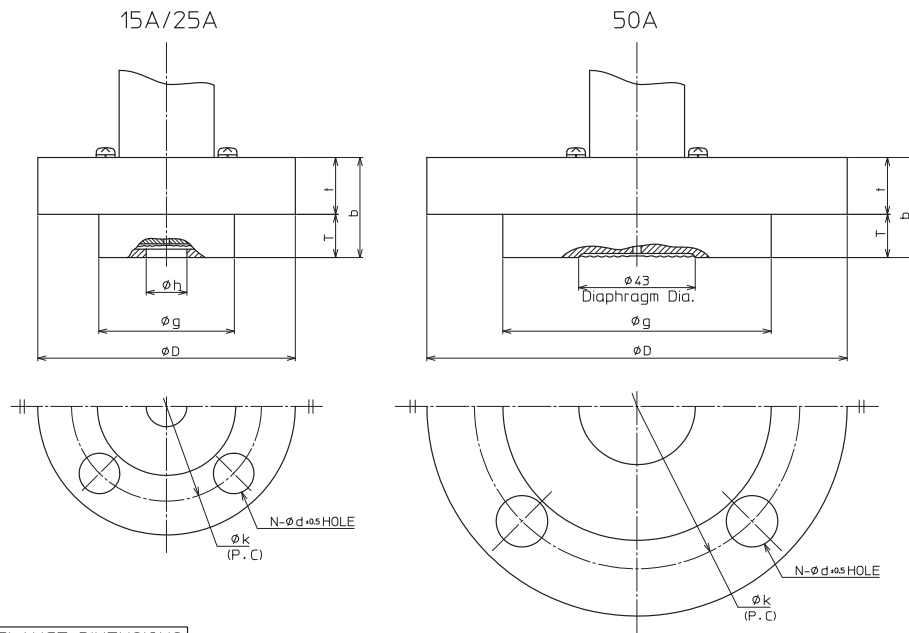

FLANGE DIMENSIONS

Flange Rating	ϕD	ϕg	ϕk	N	ϕd	ϕh	t	T	b
JIS10K-15A	95	54	70	4	15	15	12	16	28
JIS20K-15A	95	54	70	4	15	15	14	16	30
JIS30K-15A	115	54	80	4	19	15	18	16	34
JIS20K-25A	125	70	90	4	19	27	16	15.5	31.5
JIS10K-50A	155	99	120	4	19	—	16	19	35
JIS30K-50A	165	99	130	8	19	—	22	19	41

FLANGE STANDARD : JIS B2220(2004)

[mm]

ANSI/JPI-2B

ANSI/JPI-1/2B

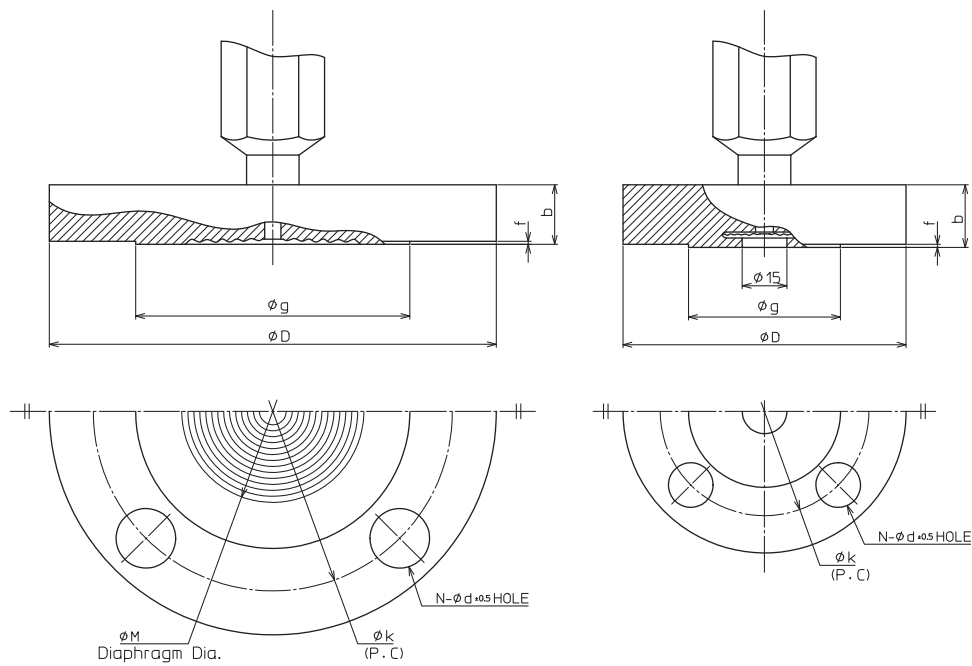

FLANGE DIMENSIONS

Flange Rating	øD	øg	øk	N	ød	øM	b	f
ANSI/JPI-150 1/2B	90	35	60.5	4	16	—	22	2
ANSI/JPI-300 1/2B	95	35	66.5	4	16	—	22	2
ANSI/JPI-600 1/2B	95	35	66.5	4	16	—	27	7
ANSI/JPI-150 2B	150	92	120.5	4	20	59	20	2
ANSI/JPI-300 2B	165	92	127	8	20	59	22.5	2
ANSI/JPI-600 2B	165	92	127	8	20	59	32.5	7

FLANGE STANDARD : ASME/ANSI B16.5(1988)
JPI-7S-15-93

Ferrule type

(1S, 1.5S, 2S clamp type)

**Measuring span / Setting range / Max. working pressure**

Model Number	Measuring span	Setting Range	Max. Working Pressure	Process Connection
PTG7_S - _3	2.0 to 100 kPa	-100 to +100 kPa	200 kPa	2S, 1.5S
PTG7_S - _4	40 to 400 kPa	-100 to +400 kPa	800 kPa or clamp rating	2S, 1.5S, 1S
PTG7_S - _5	0.2 to 2 MPa	-0.1 to +2 MPa	4 MPa or clamp rating	

Accuracy / Max. working pressure**Model PTG7_S- _3**

Accuracy *1	± 0.5% F.S. (100 kPa ≥ X ≥ 20 kPa) ± (0.5 × 20 / X)% F.S. (20 kPa ≥ X ≥ 2 kPa)	
Zero temperature effect per 30°C *1	2S (Clamp type)	± (2.4 × 40 / X + 0.35)%
	1.5S (Clamp type)	± (11.5 × 40 / X + 0.35)%

Model PTG7_S- _4

Accuracy *1	± 0.5% F.S. (400 kPa ≥ X ≥ 80 kPa) ± (0.5 × 80 / X)% F.S. (80 kPa ≥ X ≥ 40 kPa)	
Zero temperature effect per 30°C *1	2S (Clamp type)	± (1.3 × 80 / X + 0.35)%
	1.5S (Clamp type)	± (5.9 × 80 / X + 0.35)%
	1S (Clamp type)	± (30.4 × 80 / X + 0.35)%

Model PTG7_S- _5

Accuracy *1	± 0.5% F.S. (2 MPa ≥ X ≥ 0.4 MPa) ± (0.5 × 0.4 / X)% F.S. (0.4 MPa ≥ X ≥ 0.2 MPa)	
Zero temperature effect per 30°C *1	2S (Clamp type)	± (0.58 × 0.4 / X + 0.35)%
	1.5S (Clamp type)	± (1.5 × 0.4 / X + 0.35)%
	1S (Clamp type)	± (6.4 × 0.4 / X + 0.35)%

Note) *1: Within a range of URV ≥ 0 and LRV ≥ 0

Ambient temperature limits**Normal operating range**

Water and dust proof	FM Explosion proof FM Intrinsically safe KOSHA Flameproof NEPSI Flameproof (Ex d II CT4,5) ATEX Flameproof	NEPSI Flameproof (Ex d IICT6)
-10 to +70°C	-10 to +60°C	-10 to +40°C

Transportation and storage temperature

-30 to +80°C

Temperature ranges of wetted parts

Water and dust proof	FM Explosion proof FM Intrinsically safe KOSHA Flameproof NEPSI Flameproof (Ex d II CT4) ATEX Flameproof	NEPSI Flameproof (Ex d IICT5)	NEPSI Flameproof (Ex d IICT6)
-10 to +121°C	-10 to +110°C	-10 to +95°C	-10 to +80°C

150°C for 60 minutes during steam cleaning for water and dust proof model

Ambient humidity limits

5 to 100% RH

Materials**Fill fluid**

- Propylene glycol

Wetted parts

Diaphragm
SUS316L

Others
SUS316

Case

Aluminum alloy

Weight

Approx 1.2 kg

Process connection

- IDF 1S ferrule clamp type
- IDF 1.5S ferrule clamp type
- IDF 2S ferrule clamp type

For other specification, please refer to COMMON SPECIFICATIONS.

MODEL SELECTION

Smart pressure transmitter model PTG7XS

Process connection: Ferrule clamp type

Measuring span: 2.0 to 100 kPa, 40 to 400 kPa, 0.2 to 2 MPa

Model number structure: Basic model number - Selection - Option1 - Option2

Basic model number		Selection			Option1	Option2
Product description	Gauge pressure transmitter: Ferrule type with SFN communication	PTG71S				
	Gauge pressure transmitter: Ferrule type with HART communication	PTG72S				
		-				
Type of protection	Water and dust proof: IEC IP67 Electrical connection:1/2NPT	N				
	FM Explosionproof and dust-ignition Electrical connection:1/2NPT	D				
	FM Intrinsically safe Electrical connection: 1/2 NPT	E				
	KOSHA Flameproof Electrical connection: 1/2 NPT	K				
	NEPSI Flameproof and dust-ignition Electrical connection:1/2 NPT	L				
	ATEX Flameproof Electrical connection: M20 × 1.5	V				
	Measuring span	2.0 to 100 kPa (0.021 to 1.1019 kgf/cm ²) (Not applicable for process connection 1S.)	3			
40 to 400 kPa (0.408 to 4.07 kgf/cm ²)		4				
0.2 to 2 MPa (2.04 to 20.3 kgf/cm ²)		5				
Material: Diaphragm / wetted parts other than diaphragm/fill fluid	SUS316L/ SUS316L/ Propylene glycol		CB			
Process connection	IDF 1S ferrule clamp type			AH2X		
	IDF1.5S ferrule clamp type			AH3X		
	IDF 2S ferrule clamp type			AH4X		
Option 1					-	
No option					X	
Built-in digital indicator					M	
Corrosion-proof finish					B	
Wetted parts finish	Oil free finish				G	
	Water and oil free finish				H	
	Electrolytic grinding				K	
	Passive state finish				W	
Option2						-
No option						X
Test report						1
Material certificate						2
Withstand pressure test						4
Strength calculation sheet (JIS)						5
Traceability certificate						6
Non SI unit						F
Mounting bracket						H
Electrical connection: M20 × 1.5 adapter *1						T

Note) *1 Applicable only for water and dust proof "N" and FM intrinsically safe "E" in the Type of protection.

DIMENSIONS

[mm]

Materials of construction

KEY No.	Description	Materials
1	Case	Aluminum alloy
2	Body	SUS 316
3	Wetted Part	SUS 316L

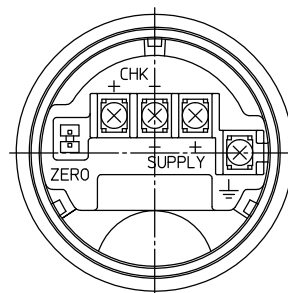

Terminal Connections
(M4 Screw)
See Table 2

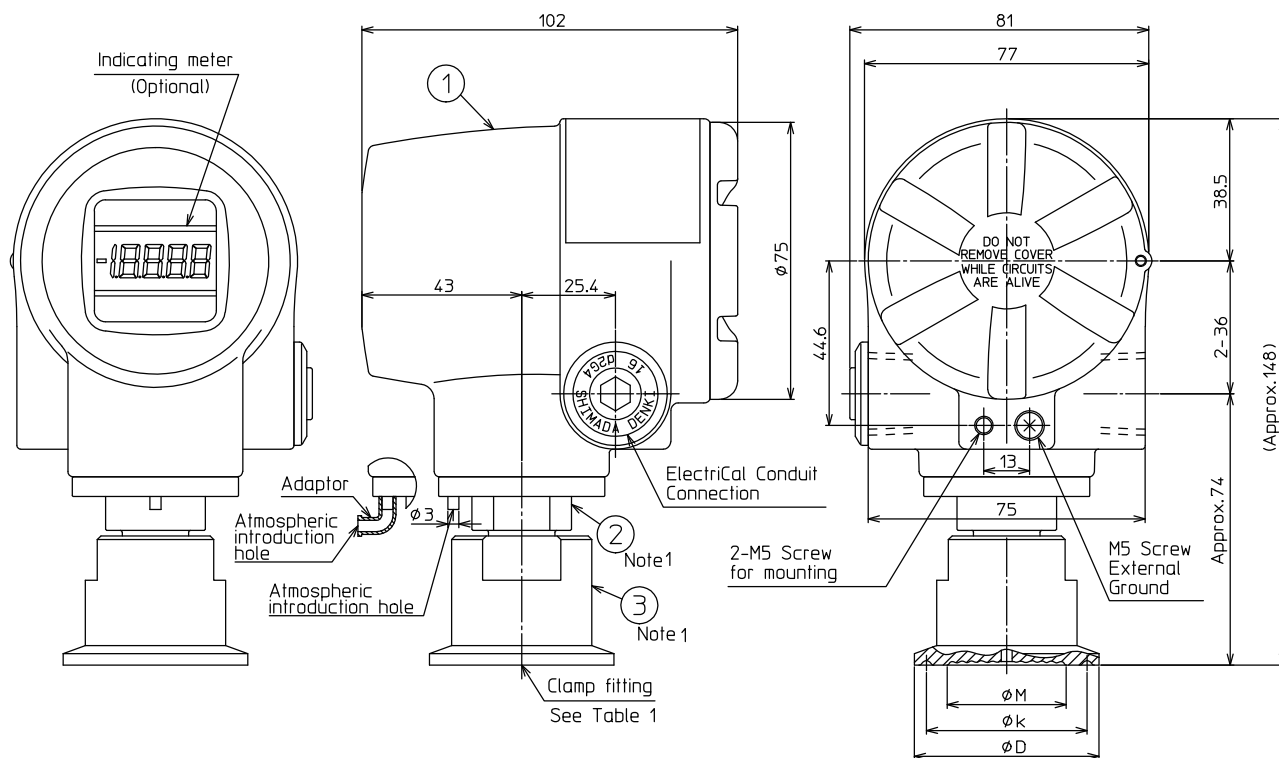

Table1

Rating	Code No.		Ferrule Size	øD	øk	øM
	Fitting	Size				
A	H	2	IDF 1S	50.5	43.5	22
		3	IDF 1.5S			
		4	IDF 2S			

Table2 Terminal

Symbol	Terminal
SUPPLY +, SUPPLY -	Power supply and output signal
CHK +, CHK -	Check meter
⏏	Ground
ZERO	ZERO Adjuster

Note 1. Do not loosen. Loosening will lead to fill-fluid leakage.

Ferrule type
(1.5S, 2S cap nut type)



Measuring Span / Setting Range / Max. Working Pressure

Model Number	Measuring span	Setting Range	Max. Working Pressure	Process Connection
PTG7_S - _3	2.0 to 100 kPa	-100 to +100 kPa	200 kPa	2S, 1.5S
PTG7_S - _4	40 to 400 kPa	-100 to +400 kPa	800 kPa or cap nut rating	
PTG7_S - _5	0.2 to 2 MPa	-0.1 to +2 MPa	4 MPa or cap nut rating	

Accuracy / Max. working pressure

Model PTG7_S- _3

Accuracy *1	± 0.5% F.S. (100 kPa ≥ X ≥ 20 kPa) ± (0.5 × 20 / X)% F.S. (20 kPa ≥ X ≥ 2 kPa)
--------------------	---

Zero temperature effect per 30°C *1	2S (Cap nut type)	± (2.4 × 40 / X + 0.35)%
	1.5S (Cap nut type)	± (11.5 × 40 / X + 0.35)%

Model PTG7_S- _4

Accuracy *1	± 0.5% F.S. (400 kPa ≥ X ≥ 80 kPa) ± (0.5 × 80 / X)% F.S. (80 kPa ≥ X ≥ 40 kPa)
--------------------	--

Zero temperature effect per 30°C *1	2S (Cap nut type)	± (1.3 × 80 / X + 0.35)%
	1.5S (Cap nut type)	± (5.9 × 80 / X + 0.35)%

Model PTG7_S- _5

Accuracy *1	± 0.5% F.S. (2 MPa ≥ X ≥ 0.4 MPa) ± (0.5 × 0.4 / X)% F.S. (0.4 MPa ≥ X ≥ 0.2 MPa)
--------------------	--

Zero temperature effect per 30°C *1	2S (Cap nut type)	± (0.58 × 0.4 / X + 0.35)%
	1.5S (Cap nut type)	± (1.5 × 0.4 / X + 0.35)%

Note) *1: Within a range of URV ≥ 0 and LRV ≥ 0

Ambient temperature limits

Normal operating range

Water and dust proof	FM Explosion proof FM Intrinsically safe KOSHA Flameproof NEPSI Flameproof (Ex d II CT4,5) ATEX Flameproof	NEPSI Flameproof (Ex d IIC T6)
-10 to +70°C	-10 to +60°C	-10 to +40°C

Transportation and storage temperature

-30 to +80°C

Temperature ranges of wetted parts

Water and dust proof	FM Explosion proof FM Intrinsically safe KOSHA Flameproof NEPSI Flameproof (Ex d II CT4) ATEX Flameproof	NEPSI Flameproof (Ex d IIC T5)	NEPSI Flameproof (Ex d IIC T6)
-10 to +121°C	-10 to +110°C	-10 to +95°C	-10 to +80°C

150°C for 60 minutes during steam cleaning for water and dust proof model

Ambient humidity limits

5 to 100% RH

Materials

Fill fluid

- Propylene glycol

Wetted parts

Diaphragm

SUS316L

Others

SUS316

Case

Aluminum alloy

Weight

- 1.5S : Approx. 1.4 kg
- 2S : Approx. 1.7 kg

Process connection

- IDF 1.5S ferrule cap nut type
- IDF 2S ferrule cap nut type

For other specification, please refer to COMMON SPECIFICATIONS.

MODEL SELECTION**Smart pressure transmitter model PTG7XS**

Process connection: Ferrule cap nut type

Measuring span: 2.0 to 100 kPa, 40 to 400 kPa, 0.2 to 2 MPa

Model number structure: Basic model number - Selection - Option1 - Option2

			Selection					Option1	Option2
Product Description	Gauge pressure transmitter: Ferrule type with SFN communication	PTG71S							
	Gauge pressure transmitter: Ferrule type with HART communication	PTG72S							
		-							
Type of protection	Water and dust proof: IEC IP67 Electrical connection: 1/2NPT		N						
	FM Explosionproof and dust-ignition Electrical connection: 1/2NPT		D						
	FM Intrinsically safe Electrical connection: 1/2 NPT		E						
	KOSHA Flameproof Electrical connection: 1/2 NPT		K						
	NEPSI Flameproof and dust-ignition Electrical connection: 1/2 NPT		L						
	ATEX Flameproof Electrical connection: M20 × 1.5		V						
Measuring span	2.0 to 100 kPa (0.021 to 1.1019 kgf/cm ²)			3					
	40 to 400 kPa (0.408 to 4.07 kgf/cm ²)			4					
	0.2 to 2 MPa (2.04 to 20.3 kgf/cm ²)			5					
Material: Diaphragm / wetted parts other than dia- phragm/fill fluid	SUS316L/SUS316L/Propylene glycol				CB				
Process connection	IDF1.5S ferrule cap nut type					AC3X			
	IDF 2S ferrule cap nut type					AC4X			
Option 1							-		
No option								X	
Built-in digital indicator								M	
Corrosion-proof finish								B	
Wetted part finish	Oil free finish							G	
	Water and oil free finish							H	
	Electrolytic grinding							K	
	Passive state finish							W	
Option2								-	
No option								X	
Test report								1	
Material certificate								2	
Withstand pressure test								4	
Strength calculation sheet (JIS)								5	
Traceability certificate								6	
Non SI unit								F	
Mounting bracket								H	
Electrical connection: M20 × 1.5 adapter *1								T	

Note) *1 Applicable only for water and dust proof "N" and FM intrinsically safe "E" in the Type of protection.

DIMENSIONS

[mm]

Materials of construction

KEY No.	Description	Materials
1	Case	Aluminum alloy
2	Body	SUS 316
3	Wetted Part	SUS 316L

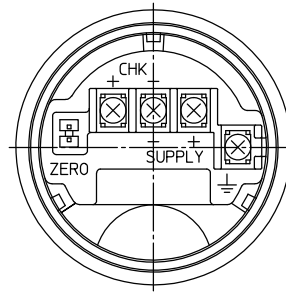

Terminal Connections
(M4 Screw)
See Table 2

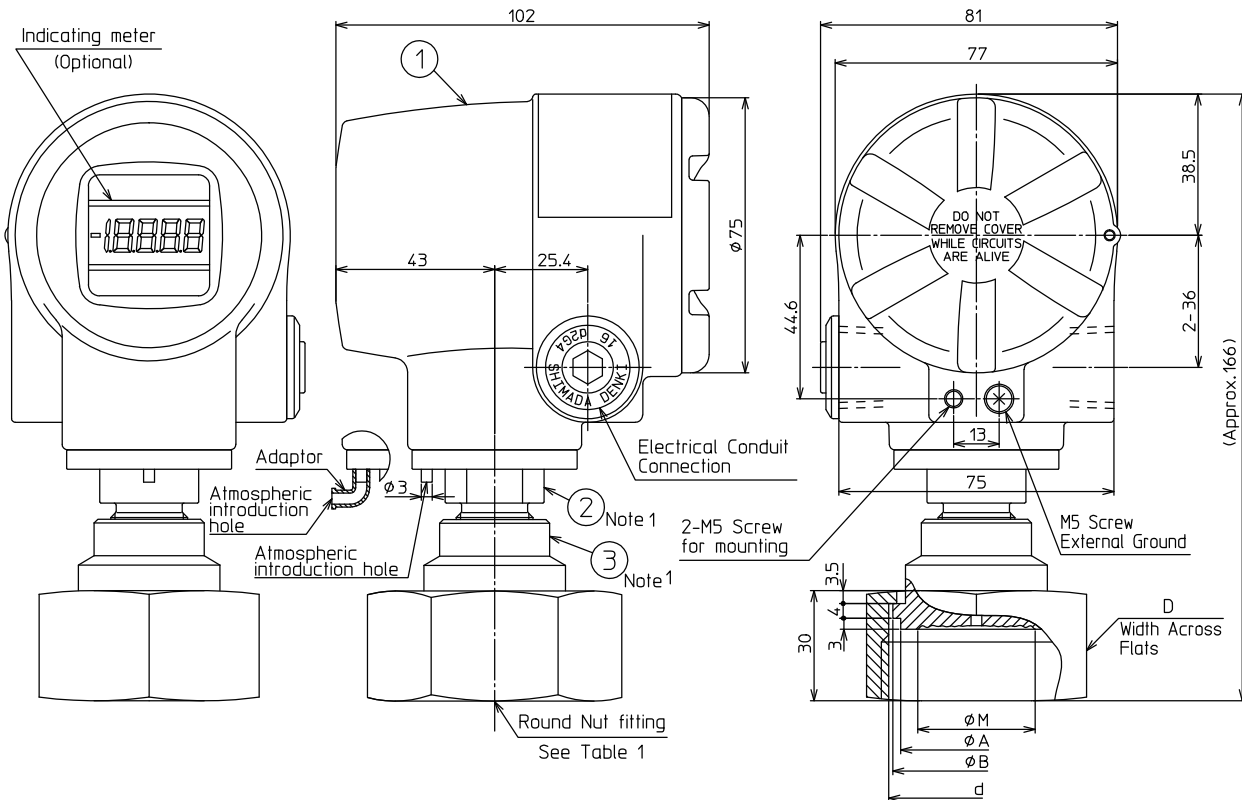

Table1

Rating	Code No.		Fitting Size(d)	D	φM	A	B
	Fitting	Size					
A	C	3	IDF 1.5S	60	28	42.7	47
		4	IDF 2S	75	43	56.2	60.5

Table2 Terminal

Symbol	Terminal
SUPPLY +, SUPPLY -	Power supply and output signal
CHK+, CHK-	Check meter
⊕	Ground
ZERO	ZERO Adjuster

Note 1. Do not loosen. Loosening will lead to fill-fluid leakage.

Ferrule with cooling tower (1S, 1.5S, 2S clamp type)



Measuring span / Setting range / Max. working pressure

Model Number	Measuring span	Setting Range	Max. Working Pressure	Process Connection
PTG7_K - _3	2.0 to 100 kPa	-100 to +100 kPa	200 kPa	2, 1.5S
PTG7_K - _4	40 to 400 kPa	-100 to +400 kPa	800 kPa or clamp rating	2S, 1.5S, 1S
PTG7_K - _5	0.2 to 2 MPa	-0.1 to +2 MPa	4 MPa or clamp rating	

Accuracy / Temperature effect

Model PTG7_K- _3

Accuracy *1	± 0.5% F.S. (100 kPa ≥ X ≥ 20 kPa) ± (0.5 × 20 / X)% F.S. (20 kPa ≥ X ≥ 2 kPa)	
Zero temperature effect per 30°C *1	2S (Clamp type)	± (2.5 × 40 / X + 0.35)%
	1.5S (Clamp type)	± (15.5 × 40 / X + 0.35)%

Model PTG7_K- _4

Accuracy *1	± 0.5% F.S. (400 kPa > X > 80 kPa) ± (0.5 × 80 / X)% F.S. (80 kPa > X > 40 kPa)	
Zero temperature effect per 30°C *1	2S (Clamp type)	± (1.4 × 80 / X + 0.35)%
	1.5S (Clamp type)	± (7.9 × 80 / X + 0.35)%
	1S (Clamp type)	± (38.4 × 80 / X + 0.35)%

Model PTG7_K- _5

Accuracy *1	± 0.5% F.S. (2 MPa > X > 0.4 MPa) ± (0.5 × 0.4 / X)% F.S. (0.4 MPa > X > 0.2 MPa)	
Zero temperature effect per 30°C *1	2S (Clamp type)	± (0.6 × 0.4 / X + 0.35)%
	1.5S (Clamp type)	± (1.9 × 0.4 / X + 0.35)%
	1S (Clamp type)	± (8.0 × 0.4 / X + 0.35)%

Note) *1: Within a range of URV ≥ 0 and LRV ≥ 0

Ambient temperature limits

Normal operating range

Water and dust proof	FM Explosion proof FM Intrinsically safe KOSHA Flameproof NEPSI Flameproof (Ex d II CT4,5) ATEX Flameproof	NEPSI Flameproof (Ex d IICT6)
-10 to +70°C	-10 to +60°C	-10 to +40°C

Transportation and storage temperature

-30 to +80°C

Temperature ranges of wetted parts

Water and dust proof	FM Explosion proof FM Intrinsically safe KOSHA Flameproof NEPSI Flameproof (Ex d II CT4) ATEX Flameproof	NEPSI Flameproof (Ex d IICT5)	NEPSI Flameproof (Ex d IICT6)
-10 to +150°C	-10 to +110°C	-10 to +95°C	-10 to +80°C

Ambient humidity limit

5 to 100% RH

Materials

Fill fluid

- Propylene glycol

Wetted parts

Diaphragm

SUS316L

Others

SUS316

Case

Aluminum alloy

Weight

Approx. 1.4 kg

Process connection

- IDF 1S ferrule clamp
- IDF 1.5S ferrule clamp
- IDF 2S ferrule clamp

For other specification, please refer to COMMON SPECIFICATIONS.

MODEL SELECTION

Smart pressure transmitter model PTG7XK

Process connection: Ferrule clamp type with cooling tower

Measuring span: 2.0 to 100 kPa, 40 to 400 kPa, 0.2 to 2 MPa

Model number structure: Basic model number - Selection - Option1 - Option2

Basic model number		Selection				Option1	Option2
Product description	Gauge pressure transmitter: Ferrule type with cooling tower with SFN communication	PTG71K					
	Gauge pressure transmitter: Ferrule type with cooling tower with HART communication	PTG72K					
		-					
Type of protection	Water and dust proof: IEC IP67 Electrical connection: 1/2NPT	N					
	FM Explosionproof and dust-ignition Electrical connection: 1/2NPT	D					
	FM Intrinsically safe Electrical connection: 1/2 NPT	E					
	KOSHA Flameproof Electrical connection: 1/2 NPT	K					
	NEPSI Flameproof and dust-ignition Electrical connection: 1/2 NPT	L					
	ATEX Flameproof Electrical connection: M20 × 1.5	V					
Measuring span	2.0 to 100 kPa (0.021 to 1.019 kgf/cm ²) (Not applicable for process connection 1S.)	3					
	40 to 400 kPa (0.408 to 4.07 kgf/cm ²)	4					
	0.2 to 2 MPa (2.04 to 20.3 kgf/cm ²)	5					
Material: Diaphragm / wetted parts other than diaphragm/fill fluid	SUS316L/ SUS316L/ Propylene glycol		CB				
Process connection	IDF 1S ferrule clamp type			AH2X			
	IDF 1.5S ferrule clamp type			AH3X			
	IDF 2S ferrule clamp type			AH4X			
Option 1						-	
No option						X	
Built-in digital indicator						M	
Corrosion-proof finish						B	
Wetted part finish	Oil free finish					G	
	Water and oil free finish					H	
	Electrolytic grinding					K	
	Passive state finish					W	
Option2						-	
No option							X
Test report							1
Material certificate							2
Withstand pressure test							4
Strength calculation sheet (JIS)							5
Traceability certificate							6
Non SI unit							F
Mounting bracket							H
Electrical connection: M20 × 1.5 adapter *1							T

Note) *1 Applicable only for water and dust proof "N" and FM intrinsically safe "E" in the Type of protection.

DIMENSIONS

[mm]

Materials of construction

KEY No.	Description	Materials
1	Case	Aluminum alloy
2	Body	SUS 316
3	Capillary A'ssy	SUS 316
4	Wetted Part	SUS 316L

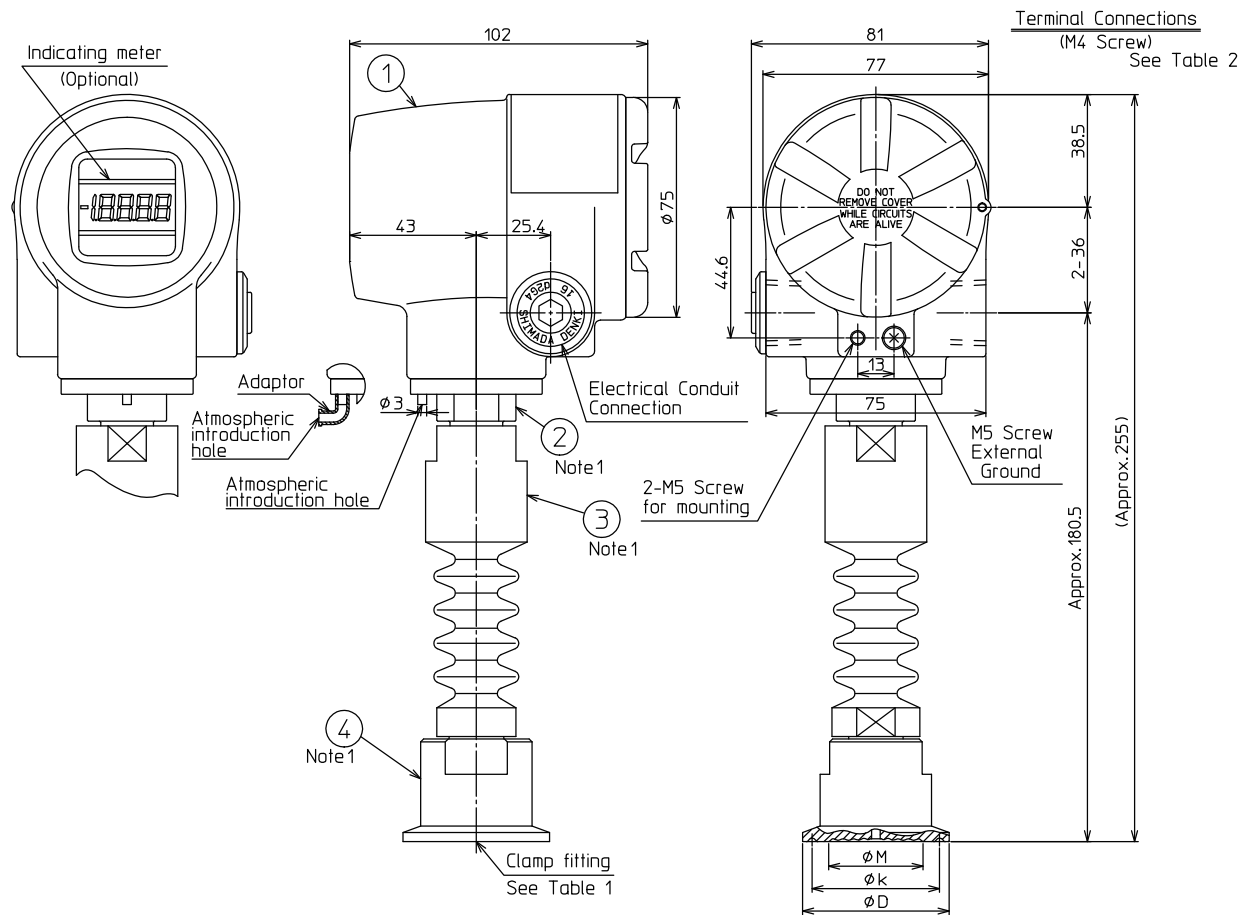
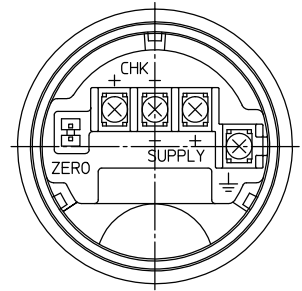

Table1

Rating	Fitting	Code No.		Ferrule Size	φD	φk	φM
		Size	Size				
A	H	2	IDF 1S	50.5	43.5	22	
		3	IDF 1.5S	50.5	43.5	28	
		4	IDF 2S	64	56.5	43	

Table2 Terminal

Symbol	Terminal
SUPPLY +, SUPPLY -	Power supply and output signal
CHK+, CHK-	Check meter
⏏	Ground
ZERO	ZERO Adjuster

Note 1. Do not loosen. Loosening will lead to fill-fluid leakage.

Ferrule with cooling tower

(1.5S, 2S cap nut type)



Measuring span/ Setting range/ Max. working pressure

Model Number	Measuring span	Setting Range	Max. Working Pressure	Process Connection
PTG7_K - _3	2.0 to 100 kPa	-100 to +100 kPa	200 kPa	2S, 1.5S
PTG7_K - _4	40 to 400 kPa	-100 to +400 kPa	800 kPa or cap nut rating	
PTG7_K - _5	0.2 to 2 MPa	-0.1 to +2 MPa	4 MPa or cap nut rating	

Accuracy / Temperature effect

Model PTG7_K- _3

Accuracy *1	± 0.5% F.S. (100 kPa ≥ X ≥ 20 kPa) ± (0.5 × 20 / X)% F.S. (20 kPa ≥ X ≥ 2 kPa)
-------------	---

Zero temperature effect per 30°C *1	2S (Cap nut type)	± (2.5 × 40 / X + 0.35)%
	1.5S (Cap nut type)	± (15.5 × 40 / X + 0.35)%

Model PTG7_K- _4

Accuracy *1	± 0.5% F.S. (400 kPa ≥ X ≥ 80 kPa) ± (0.5 × 80 / X)% F.S. (80 kPa ≥ X ≥ 40 kPa)
-------------	--

Zero temperature effect per 30°C *1	2S (Cap nut type)	± (1.4 × 80 / X + 0.35)%
	1.5S (Cap nut type)	± (7.9 × 80 / X + 0.35)%

Model PTG7_K- _5

Accuracy *1	± 0.5% F.S. (2 MPa ≥ X ≥ 0.4 MPa) ± (0.5 × 0.4 / X)% F.S. (0.4 MPa ≥ X ≥ 0.2 MPa)
-------------	--

Zero temperature effect per 30°C *1	2S (Cap nut type)	± (0.6 × 0.4 / X + 0.35)%
	1.5S (Cap nut type)	± (1.9 × 0.4 / X + 0.35)%

Note) *1: Within a range of URV ≥ 0 and LRV ≥ 0

Ambient temperature limits

Normal operating range

Water and dust proof	FM Explosion proof FM Intrinsically safe KOSHA Flameproof NEPSI Flameproof (Ex d II CT4,5) ATEX Flameproof	NEPSI Flameproof (Ex d IICT6)
-10 to +70°C	-10 to +60°C	-10 to +40°C

Transportation and storage temperature

-30 to +80°C

Temperature ranges of wetted parts

Water and dust proof	FM Explosion proof FM Intrinsically safe KOSHA Flameproof NEPSI Flameproof (Ex d II CT4) ATEX Flameproof	NEPSI Flameproof (Ex d IICT5)	NEPSI Flameproof (Ex d IICT6)
-10 to +150°C	-10 to +110°C	-10 to +95°C	-10 to +80°C

Ambient humidity limits

5 to 100% RH

Materials

Fill fluid

- Propylene glycol

Wetted parts

Diaphragm

SUS316L

Others

SUS316

Case

Aluminum alloy

Weight

- 1.5S: Approx. 1.6 kg
- 2S: Approx. 1.9 kg

Process connection

- IDF 1.5S ferrule cap nut type
- IDF 2S ferrule cap nut type

For other specification, please refer to COMMON SPECIFICATIONS.

MODEL SELECTION**Smart pressure transmitter model PTG7XK**

Process connection: Ferrule cap nut type with cooling tower

Measuring span 2.0 to 100 kPa, 40 to 400 kPa, 0.2 to 2 MPa

Model number structure: Basic model number - Selection - Option1 - Option2

Basic model number		Selection				Option1	Option2
Product description	Gauge pressure transmitter: Ferrule type with cooling tower with SFN communication	PTG71K					
	Gauge pressure transmitter: Ferrule type with cooling tower with HART Communication	PTG72K					
		-					
Type of protection	Water and dust proof: IEC IP67 Electrical connection:1/2NPT	N					
	FM Explosionproof and dust-ignition Electrical connection:1/2NPT	D					
	FM Intrinsically safe Electrical connection: 1/2 NPT	E					
	KOSHA Flameproof Electrical connection: 1/2 NPT	K					
	NEPSI Flameproof and dust-ignition Electrical connection:1/2 NPT	L					
	ATEX Flameproof Electrical connection: M20 × 1.5	V					
Measuring span	2.0 to 100 kPa (0.021 to 1.019 kgf/cm ²) (Applicable only for process connection 2S)	3					
	40 to 400 kPa (0.408 to 4.07 kgf/cm ²)	4					
	0.2 to 2 MPa (2.04 to 20.3 kgf/cm ²)	5					
Material: Diaphragm / wetted parts other than diaphragm/fill fluid	SUS316L / SUS316L / Propylene glycol		CB				
Process connection	IDF 1.5S ferrule cap nut type			AC3X			
	IDF 2S ferrule cap nut type			AC4X			
Option 1						-	
No option						X	
Built-in digital indicator						M	
Corrosion-proof finish						B	
Wetted part finish	Oil free finish					G	
	Water and oil free finish					H	
	Electrolytic grinding					K	
	Passive state finish					W	
Option2						-	
No option							X
Test report							1
Material certificate							2
Withstand pressure test							4
Strength calculation sheet (JIS)							5
Traceability certificate							6
Non SI unit							F
Mounting bracket							H
Electrical connection: M20 × 1.5 adapter *1							T

Note) *1 Applicable only for water and dust proof "N" and FM intrinsically safe "E" in the Type of protection.

DIMENSIONS

[mm]

Materials of construction

KEY No.	Description	Materials
1	Case	Aluminum alloy
2	Body	SUS 316
3	Capillary A'ssy	SUS 316
4	Wetted Part	SUS 316L

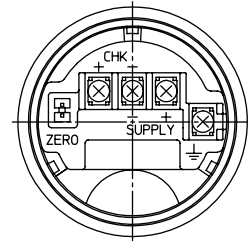

Terminal Connections
(M4 Screw)
See Table 2

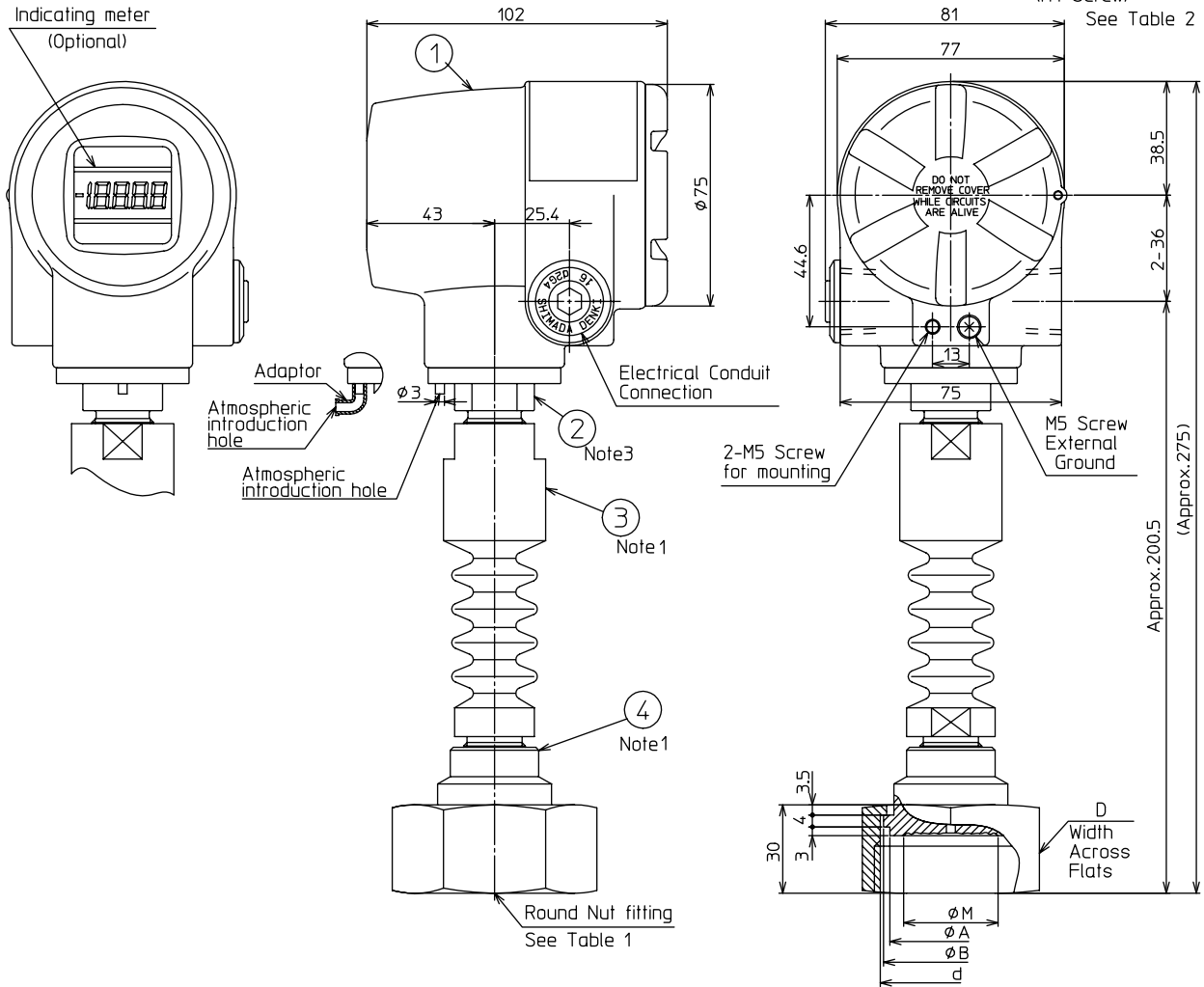

Table1

Rating	Code No.		Fitting Size(d)	D	φM	A	B
	Fitting	Size					
A	C	3	IDF 1.5S	60	28	42.7	47
		4	IDF 2S	75	43	56.2	60.5

Table2 Terminal

Symbol	Terminal
SUPPLY +, SUPPLY -	Power supply and output signal
CHK+, CHK-	Check meter
⏏	Ground
ZERO	ZERO Adjuster

Note 1. Do not loosen. Loosening will lead to fill-fluid leakage.

Remote seal with ferrule type (1.5S, 2S clamp type)



Measuring span/ Setting range/ Max. working pressure

Model Number	Measuring span	Setting Range	Max. Working Pressure	Process Connection
PTG7_T - _3	2.0 to 100 kPa	-100 to +100 kPa	200 kPa	2S
PTG7_T - _4	40 to 400 kPa	-100 to +400 kPa	800 kPa or clamp rating	2S, 1.5S
PTG7_T - _5	0.2 to 2 MPa	-0.1 to +2 MPa	4 MPa or clamp rating	

Accuracy / Temperature effect

Model PTG7_T - _3

Accuracy *1	$\pm 0.5\%$ F.S. ($100 \text{ kPa} \geq X \geq 20 \text{ kPa}$) $\pm (0.5 \times 20 / X)\%$ F.S. ($20 \text{ kPa} \geq X \geq 2 \text{ kPa}$)
-------------	--

Zero temperature effect per 30°C *1	2S (Clamp type)	$\pm (11.5 \times 40 / X + 0.35)\%$
-------------------------------------	-----------------	-------------------------------------

Model PTG7_T - _4

Accuracy *1	$\pm 0.5\%$ F.S. ($400 \text{ kPa} \geq X \geq 80 \text{ kPa}$) $\pm (0.5 \times 80 / X)\%$ F.S. ($80 \text{ kPa} \geq X \geq 40 \text{ kPa}$)
-------------	---

Zero temperature effect per 30°C *1	2S (Clamp type)	$\pm (5.9 \times 80 / X + 0.35)\%$
	1.5S (Clamp type)	$\pm (33.9 \times 80 / X + 0.35)\%$

Model PTG7_T - _5

Accuracy *1	$\pm 0.5\%$ F.S. ($2 \text{ MPa} \geq X \geq 0.4 \text{ MPa}$) $\pm (0.5 \times 0.4 / X)\%$ F.S. ($0.4 \text{ MPa} \geq X \geq 0.2 \text{ MPa}$)
-------------	---

Zero temperature effect per 30°C *1	2S (Clamp type)	$\pm (1.5 \times 0.4 / X + 0.35)\%$
	1.5S (Clamp type)	$\pm (7.1 \times 0.4 / X + 0.35)\%$

Note) *1: Within a range of $URV \geq 0$ and $LRV \geq 0$

Ambient temperature limits

Normal operating range

	Water and dust proof FM Explosion proof FM Intrinsically safe KOSHA Flameproof NEPSI Flameproof (Ex d II CT4,5) ATEX Flameproof	NEPSI Flameproof (Ex d IIC T6)
IDF 1.5 S	-5 to +55°C	-5 to +40°C
IDF 2 S	-5 to +60°C	-5 to +40°C

Transportation and storage temperature

-30 to +80°C

Temperature range of wetted parts

Water and dust proof	FM Explosion proof FM Intrinsically safe KOSHA Flameproof NEPSI Flameproof (Ex d II CT4) ATEX Flameproof	NEPSI Flameproof (Ex d IIC T5)	NEPSI Flameproof (Ex d IIC T6)
-5 to +121°C	-5 to +110°C	-5 to +95°C	-5 to +80°C

150°C for 60 minutes during steam cleaning for water and dust proof model

Ambient humidity limits

5 to 100% RH

Materials

Fill fluid

- Propylene glycol

Wetted parts

Diaphragm

SUS316L

Others

SUS316

Case

Aluminum alloy

Capillary cover

Olefin

Weight

Approx. 1.8 kg (Capillary length 3 m)

Process connection

- IDF 1.5S ferrule clamp type
- IDF 2S ferrule clamp type

For other specification, please refer to COMMON SPECIFICATIONS.

Note) *1 Applicable only for water and dust proof "N" and FM intrinsically safe "E" in the type of protection.

MODEL SELECTION

Smart pressure transmitter model PTG7XT

Process connection: Remote seal with ferrule clamp type

Measuring span: 2.0 to 100 kPa, 40 to 400 kPa, 0.2 to 2 MPa

Model number structure: Basic model number - Selection - Option1 - Option2

			Selection					Option1	Option2
Product description	Gauge pressure transmitter: Ferrule type with remote seal with SFN Communication	PTG71T							
	Gauge pressure transmitter: Ferrule type with remote seal with HART Communication	PTG72T							
		-							
Type of protection	Water and dust proof: IEC IP67 Electrical connection:1/2NPT		N						
	FM Explosionproof and dust-ignition Electrical connection:1/2NPT		D						
	FM Intrinsically safe Electrical connection: 1/2 NPT		E						
	KOSHA Flameproof Electrical connection: 1/2 NPT		K						
	NEPSI Flameproof and dust-ignition Electrical connection:1/2 NPT		L						
	ATEX Flameproof Electrical connection: M20 × 1.5		V						
Measuring span	2.0 to 100 kPa (0.021 to 1.019 kgf/cm ²) (Not applicable for process connection 1S)			3					
	40 to 400 kPa (0.408 to 4.07 kgf/cm ²)			4					
	0.2 to 2 MPa (2.04 to 20.3 kgf/cm ²)			5					
Material: Diaphragm / wetted parts other than diaphragm/fill fluid	SUS316L/SUS316L/Propylene glycol				CB				
Process connection	IDF 1.5S ferrule clamp type					AH3X			
	IDF 2S ferrule clamp type					AH4X			
Capillary length	1 m (with Olefin tube)					E			
	3 m (with Olefin tube)					G			
	5 m (with Olefin tube)					J			
Option 1							-		
No option							X		
Corrosion-proof finish							B		
Built-in digital indicator							M		
Wetted parts finish	Oil free finish						G		
	Water and oil free finish						H		
	Electrolytic grinding						K		
	Passive state finish						W		
Option2								-	
No option								X	
Test report								1	
Material certificate								2	
Withstand pressure test								4	
Strength calculation sheet (JIS)								5	
Traceability certificate								6	
Non SI unit								F	
Mounting bracket								H	
Electrical connection: M20 × 1.5 adapter *1								T	

Note) *1 Applicable only for water and dust proof “N” and FM intrinsically safe “E” in the Type of protection.

DIMENSIONS

[mm]

DIMENSIONAL DRAWING UNIT : mm

Materials of construction

KEY No.	Description	Materials
1	Case	Aluminum alloy
2	Body	SUS 316
3	Capillary A'ssy	SUS 304(Olefin cover)
4	Wetted Part	SUS 316L

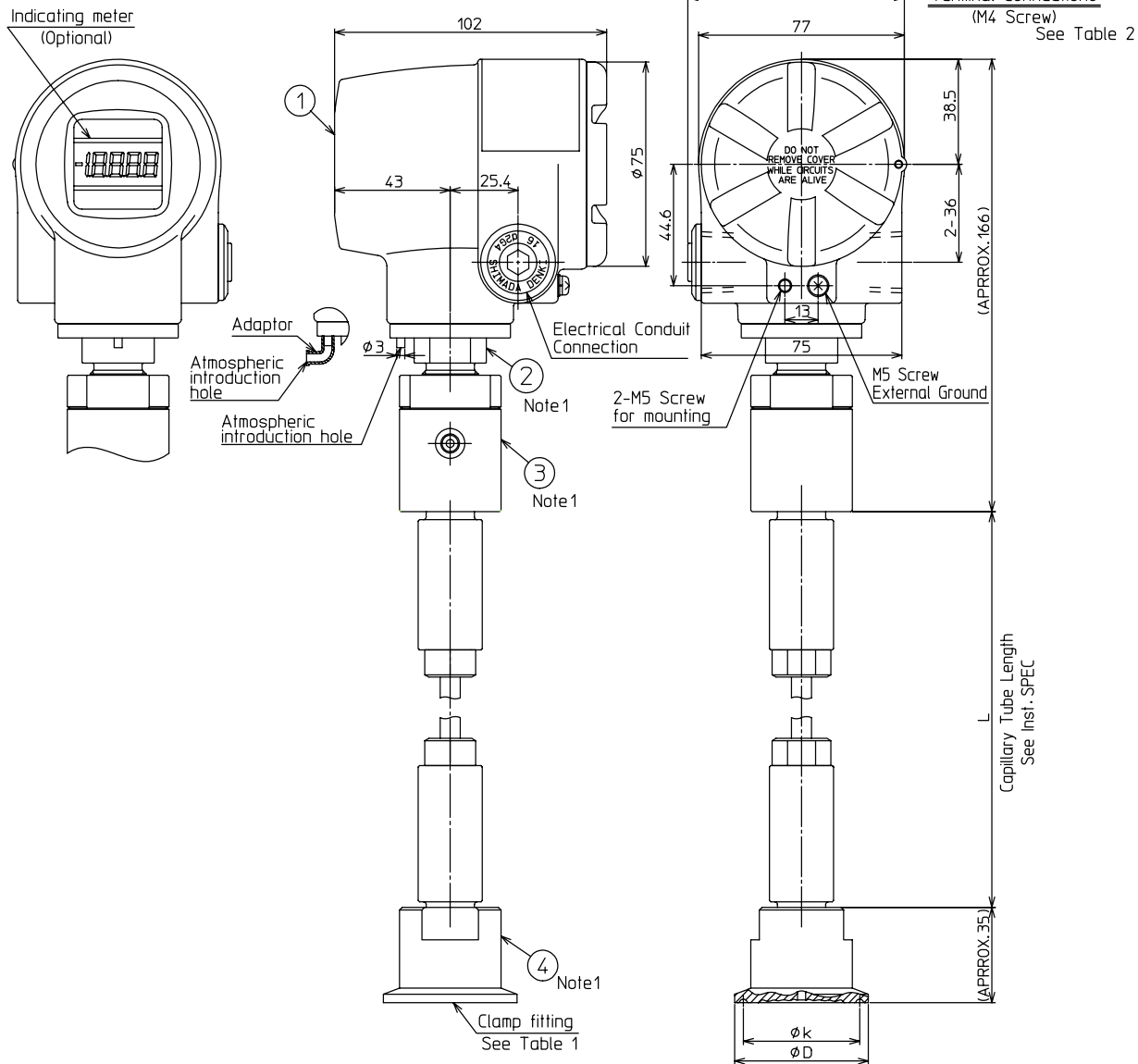

Note 1. Do not loosen. Loosening will lead to fill-fluid leakage.

Table1

Rating	Code No.		Ferrule Size	øD	øk	øM
	Fitting	Size				
A	H	2	IDF 1S	50.5	43.5	22
		3	IDF 1.5S	64	56.5	28
		4	IDF 2S	64	56.5	43

Table2 Terminal

Symbol	Terminal
SUPPLY +, SUPPLY -	Power supply and output signal
CHK+, CHK-	Check meter
⊥	Ground
ZERO	ZERO Adjuster

Remote seal with ferrule type
(1S, 2S cap nut type)



Measuring span/ Setting range/ Max. working pressure

Model Number	Measuring span	Setting Range	Max. Working Pressure	Process Connection
PTG7_T - _3	2.0 to 100 kPa	-100 to +100 kPa	200 kPa	2S
PTG7_T - _4	40 to 400 kPa	-100 to +400 kPa	800 kPa or cap nut rating	2S, 1.5S
PTG7_T - _5	0.2 to 2 MPa	-0.1 to +2 MPa	4 MPa or cap nut rating	

Accuracy / Temperature effect

Model PTG7_T- _3

Accuracy *1	± 0.5% F.S. (100 kPa ≥ X ≥ 20 kPa) ± (0.5 × 20 / X)% F.S. (20 kPa ≥ X ≥ 2 kPa)
-------------	---

Zero temperature effect per 30°C *1	2S (Cap nut type) ± (11.5×40 / X +0.35)%
-------------------------------------	--

Model PTG7_T- _4

Accuracy *1	± 0.5% F.S. (400 kPa ≥ X ≥ 80 kPa) ± (0.5 × 80 / X)% F.S. (80 kPa ≥ X ≥ 40 kPa)
-------------	--

Zero temperature effect per 30°C *1	2S (Cap nut type) ± (5.9 × 80 / X +0.35)% 1.5S (Cap nut type) ± (33.9 × 80 / X +0.35)%
-------------------------------------	---

Model PTG7_T- _5

Accuracy *1	± 0.5% F.S. (2 MPa > X > 0.4 MPa) ± (0.5 × 0.4 / X)% F.S. (0.4 MPa > X > 0.2 MPa)
-------------	--

Zero temperature effect per 30°C *1	2S (Cap nut type) ± (1.5 × 0.4 / X +0.35)% 1.5S (Cap nut type) ± (7.1 × 0.4 / X +0.35)%
-------------------------------------	--

Note) *1: Within a range of URV ≥ 0 and LRV ≥ 0

Ambient temperature limits

Normal operating range

	Water and dust proof FM Explosion proof FM Intrinsically safe KOSHA Flameproof NEPSI Flameproof (Ex d II CT4,5) ATEX Flameproof	NEPSI Flameproof (Ex d IICT6)
IDF 1.5 S	-5 to +55°C	-5 to +40°C
IDF 2 S	-5 to +60°C	-5 to +40°C

Transportation and storage temperature

-30 to +80°C

Temperature range of wetted parts

Water and dust proof	FM Explosion proof FM Intrinsically safe KOSHA Flameproof NEPSI Flameproof (Ex d II CT4) ATEX Flameproof	NEPSI Flameproof (Ex d IICT5)	NEPSI Flameproof (Ex d IICT6)
-5 to +121°C	-5 to +110°C	-5 to +95°C	-5 to +80°C

150°C for 60 minutes during steam cleaning for water and dust proof model

Ambient humidity limits

5 to 100% RH

Materials

Fill fluid

- Propylene glycol

Wetted parts

Diaphragm

SUS316L

Others

SUS316

Case

Aluminum alloy

Capillary cover

Olefin

Weight

Approx. 2.3 kg (Capillary length 3 m)

Process connection

- IDF 1.5S ferrule cap nut type
- IDF 2S ferrule cap nut type

For other specification, please refer to COMMON SPECIFICATIONS.

MODEL SELECTION**Smart pressure transmitter model PTG7XT**

Process connection: Remote seal with ferrule cap nut type

Measuring span 2.0 to 100 kPa, 40 to 400 kPa, 0.2 to 2 MPa

Model number structure: Basic model number - Selection - Option1 - Option 2

			Selection					Option1	Option2
Product description	Gauge pressure transmitter: Ferrule type with remote seal with SFN communication	PTG71T							
	Gauge Pressure Transmitter: Ferrule type with remote seal with HART Communication	PTG72T							
			-						
Type of protection	Water and dust proof: IEC IP67 Electrical connection: 1/2NPT		N						
	FM Explosionproof and dust-ignition Electrical connection: 1/2NPT		D						
	FM Intrinsically safe Electrical connection: 1/2 NPT		E						
	KOSHA Flameproof Electrical connection: 1/2 NPT		K						
	NEPSI Flameproof and dust-ignition Electrical connection: 1/2 NPT		L						
	ATEX Flameproof Electrical connection: M20 × 1.5		V						
Measuring span	2.0 to 100 kPa (0.021 to 1.019 kgf/cm ²)		3						
	40 to 400 kPa (0.408 to 4.07 kgf/cm ²)		4						
	0.2 to 2 MPa (2.04 to 20.3 kgf/cm ²)		5						
Material: Diaphragm / wetted parts other than diaphragm/fill fluid	SUS316L / SUS316L / Propylene glycol			CB					
Process connection	IDF 1.5S ferrule cap nut type				AC3X				
	IDF 2S ferrule cap nut type				AC4X				
Capillary length	1 m (with Olefin tube)					E			
	3 m (with Olefin tube)					G			
	5 m (with Olefin tube)					J			
Option 1							-		
No option							X		
Corrosion-proof finish							B		
Built-in digital indicator							M		
Wetted parts finish	Oil free finish						G		
	Water and oil free finish						H		
	Electrolytic grinding						K		
	Passive state finish						W		
Option2								-	
No option								X	
Test report								1	
Material certificate								2	
Withstand pressure test								4	
Strength calculation sheet (JIS)								5	
Traceability certificate								6	
Non SI unit								F	
Mounting bracket								H	
Electrical connection: M20 × 1.5 adapter *1								T	

Note) *1 Applicable only for water and dust proof "N" and FM intrinsically safe "E" in the Type of protection.

