

KG Series Model KGP Pressure Indicating Controller

OVERVIEW

Model KGP Field Mounted Pressure Indicating Controller measures, indicates and controls process pressure. It measures pressure by detecting it into mechanical displacement with a bellows or a spiral pressure sensors. The KG is a simplified dedicated-purpose instrument which is greatly economical and reliable.



FEATURES

- **Vibration-resistant**

The spiral element is provided with a balancing weight to suppress vibration of PV pointer, deflection angle is referenced to the center of moment, and a provision is made to prevent eccentricity of center of deflection angle.

- **Twin bellows**

P-action unit bellows is made up of a single bellows separated into two chambers. It provides excellent matching of effective areas and operates very reliably.

- **Case**

The case is sturdy and highly resistant against heat, weather, and vibration.

SPECIFICATIONS**Standard Specifications**

Item	Specification												
Detector section													
Measuring range, Maximum allowable pressure, Element type and Process connection	<table border="1"> <thead> <tr> <th>Measuring range</th> <th>Max. allowable pressure</th> <th>Element type</th> <th>Process connection</th> </tr> </thead> <tbody> <tr> <td>20 to 100 kPa { 0.2 to 1.0 kgf/cm² }</td> <td>150 kPa { 1.5 kgf/cm² }</td> <td>Bellows</td> <td>Rc 1/4 or 1/4 NPT internal thread</td> </tr> <tr> <td>0 to 300 kPa { 3 kgf/cm² } 0 to 500 kPa { 5 kgf/cm² } 0 to 1000 kPa { 10 kgf/cm² } 0 to 1500 kPa { 15 kgf/cm² } 0 to 2000 kPa { 20 kgf/cm² } 0 to 3500 kPa { 35 kgf/cm² } 0 to 5000 kPa { 50 kgf/cm² } 0 to 10 MPa { 100 kgf/cm² }</td> <td>450 kPa { 4.5 kgf/cm² } 750 kPa { 4.5 kgf/cm² } 1500 kPa { 15 kgf/cm² } 2250 kPa { 22.5 kgf/cm² } 3000 kPa { 30 kgf/cm² } 5250 kPa { 52.5 kgf/cm² } 7500 kPa { 75 kgf/cm² } 12 MPa { 120 kgf/cm² }</td> <td>Spiral</td> <td>G 1/4 internal thread</td> </tr> </tbody> </table>	Measuring range	Max. allowable pressure	Element type	Process connection	20 to 100 kPa { 0.2 to 1.0 kgf/cm ² }	150 kPa { 1.5 kgf/cm ² }	Bellows	Rc 1/4 or 1/4 NPT internal thread	0 to 300 kPa { 3 kgf/cm ² } 0 to 500 kPa { 5 kgf/cm ² } 0 to 1000 kPa { 10 kgf/cm ² } 0 to 1500 kPa { 15 kgf/cm ² } 0 to 2000 kPa { 20 kgf/cm ² } 0 to 3500 kPa { 35 kgf/cm ² } 0 to 5000 kPa { 50 kgf/cm ² } 0 to 10 MPa { 100 kgf/cm ² }	450 kPa { 4.5 kgf/cm ² } 750 kPa { 4.5 kgf/cm ² } 1500 kPa { 15 kgf/cm ² } 2250 kPa { 22.5 kgf/cm ² } 3000 kPa { 30 kgf/cm ² } 5250 kPa { 52.5 kgf/cm ² } 7500 kPa { 75 kgf/cm ² } 12 MPa { 120 kgf/cm ² }	Spiral	G 1/4 internal thread
	Measuring range	Max. allowable pressure	Element type	Process connection									
20 to 100 kPa { 0.2 to 1.0 kgf/cm ² }	150 kPa { 1.5 kgf/cm ² }	Bellows	Rc 1/4 or 1/4 NPT internal thread										
0 to 300 kPa { 3 kgf/cm ² } 0 to 500 kPa { 5 kgf/cm ² } 0 to 1000 kPa { 10 kgf/cm ² } 0 to 1500 kPa { 15 kgf/cm ² } 0 to 2000 kPa { 20 kgf/cm ² } 0 to 3500 kPa { 35 kgf/cm ² } 0 to 5000 kPa { 50 kgf/cm ² } 0 to 10 MPa { 100 kgf/cm ² }	450 kPa { 4.5 kgf/cm ² } 750 kPa { 4.5 kgf/cm ² } 1500 kPa { 15 kgf/cm ² } 2250 kPa { 22.5 kgf/cm ² } 3000 kPa { 30 kgf/cm ² } 5250 kPa { 52.5 kgf/cm ² } 7500 kPa { 75 kgf/cm ² } 12 MPa { 120 kgf/cm ² }	Spiral	G 1/4 internal thread										
Element material	Bellows : Phosphor bronze Spiral : SUS316												
Performance													
Indicating accuracy	± 1.0% FS												
Repeatability	Within 0.5% FS												
Dead band	Within 0.3% FS												
Indicator section													
Indicating angle	44 degrees												
Scale length	111.3 mm												
Pointers	PV: Red SP: Green												
Setting section													
Setting method	Local setting (internal setting with a setting knob of case inside.)												
Setting range	0 to 100 % FS												
Controller section													
Control mode	PI action , PID action												
Controller performance	Proportional band (P) : 5 to 500% (direct or reverse action) Integral time (I) : 0.05 to 30 min. Derivative time (D) : 0.05 to 30 min.												
General specification													
Output	20 to 100 kPa { 0.2 to 1.0 kgf/cm ² }												
Minimum load	ID 4 mm × 3 m + 20 cm ³												
Supply air pressure	140 ± 14 kPa { 1.4 ± 1.4 kgf/cm ² }												
Air consumption	5 L/min [N]												
Pneumatic delivery capacity	40 L/min [N]												
Pneumatic exhaust capacity	40 L/min [N]												
Supply and output connection	Rc 1/4 or 1/4 NPT internal thread												
Ambient temperature	-30 to 75 °C												
Ambient humidity	10 to 90% RH												
Material	Case and door: FRP (polyester with fiber glass)												
	Interior air pipe: Urethane												
	Mounting bracket: Carbon steel (zinc plated)												
	Mounting bolt and nut: SUS304												
Applicable standards	<ul style="list-style-type: none"> • JIS F8001 class 3 splash proof, NEMA type 3 and IEC IP54 equivalent. • Lloyd's Register of Shipping and Nippon Kaiji Kyokai rule authorized • JIS F0807 equivalent 												
Color of finish	Direct mounting without bracket, 2 in. pipe mounting or Surface mounting.												
Mounting method	2 in. pipe or wall mounting												
Weight	Approx. 5 kg (KGPA12-01010A1T-X)												

Optional Specification

Item	Specifications						
(1) With Pressure regulator with filter	Pressure regulator with filter plus 40 mm Pressure gauge <table border="1"> <tbody> <tr> <td>primary pressure;</td> <td>200 to 990 kPa { 2 to 9.9 kgf/cm² }</td> </tr> <tr> <td>secondary pressure;</td> <td>140 kPa { 1.4 kgf/cm² }</td> </tr> <tr> <td>pressure gauge range;</td> <td>0 to 200 kPa { 0 to 2 kgf/cm² }</td> </tr> </tbody> </table>	primary pressure;	200 to 990 kPa { 2 to 9.9 kgf/cm ² }	secondary pressure;	140 kPa { 1.4 kgf/cm ² }	pressure gauge range;	0 to 200 kPa { 0 to 2 kgf/cm ² }
primary pressure;	200 to 990 kPa { 2 to 9.9 kgf/cm ² }						
secondary pressure;	140 kPa { 1.4 kgf/cm ² }						
pressure gauge range;	0 to 200 kPa { 0 to 2 kgf/cm ² }						
(2) With output gauge	Range: 0 to 200 kPa { 0 to 2 kgf/cm ² }						

MODEL SELECTION

Ex: KGPA 12-01003A 1S-G

Basic model no.			Selections					Options	Description
Type	Function	Control action	Sensing element	Measuring range	Air connection	Output pressure unit	Mounting method		
KGP								Pressure indicating controller	
	A1							Local type controller	
		2						PI	
		3						PID	
			01					Spiral	
			03					Bellows	
				003				0 to 300 kPa {3 kgf/cm ² } (spiral type)	
				005				0 to 500 kPa {5 kgf/cm ² } (spiral type)	
				010				0 to 1000 kPa {10 kgf/cm ² } (spiral type)	
				015				0 to 1500 kPa {15 kgf/cm ² } (spiral type)	
				020				0 to 2000 kPa {20 kgf/cm ² } (spiral type)	
				035				0 to 3500 kPa {35 kgf/cm ² } (spiral type)	
				050				0 to 5000 kPa {50 kgf/cm ² } (spiral type)	
				100				0 to 10 MPa {100 kgf/cm ² } (spiral type)	
				821				20 to 100 kPa {0.2 to 1.0 kgf/cm ² } (bellows type)	
					A			Rc 1/4	
					B			1/4 NPT internal thread	
						1		0.2 to 1.0 kgf/cm ²	
						2		3 to 15 PSI	
						3		0.2 to 1.0 bar	
						4		20 to 100 kPa {0.2 to 1.0 kgf/cm ² }	
						8		19.6 to 98.1 kPa (equality to 0.2 to 1.0 kgf/cm ²)	
							M	Direct mounting without bracket *1	
							S	Wall mounting	
							T	2 in. pipe mounting	
							X	No option	
							7	With Pressure regulator with filter	
							G	With output gauge (40 mm.)	
							D	With damping unit *1	

*1 Not available with pressure regulator with filter.

DIMENSIONS

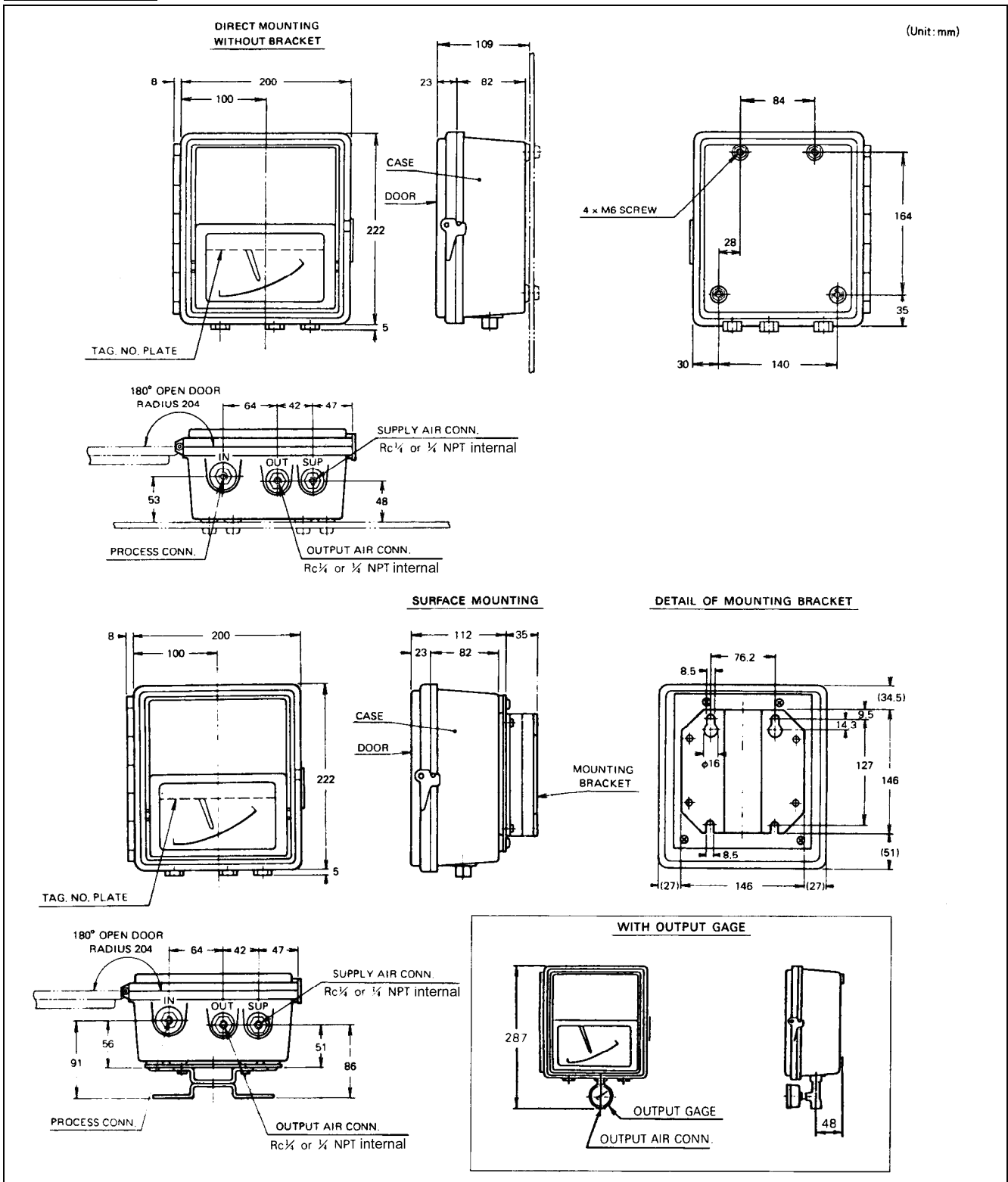

Please read the "Terms and Conditions" from the following URL before ordering or use:

<http://www.azbil.com/products/bi/order.html>

Specifications are subject to change without notice.

azbil

Azbil Corporation
Advanced Automation Company

1-12-2 Kawana, Fujisawa
Kanagawa 251-8522 Japan
URL: <http://www.azbil.com/>

1st Edition: Issued in Aug. 2000
2nd Edition: Issued in Dec 2012

No part of this publication may be reproduced or duplicated without the prior written permission of Azbil Corporation.