

Hybrid Recorder SR100 (Multi-point Type) Instruction Manual Wiring/Installation

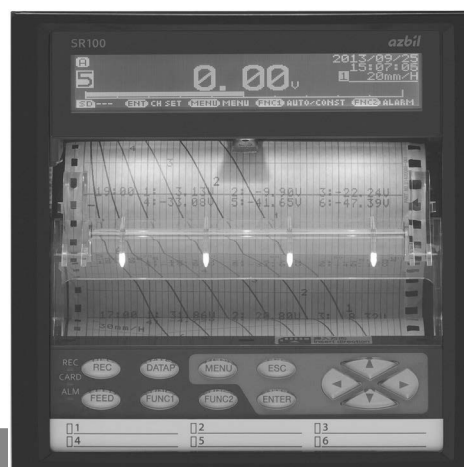

Thank you for purchasing the SR series Hybrid Recorder.

This manual contains information for ensuring the correct use of the SR series Hybrid Recorder. It also provides necessary information for installation, maintenance, and troubleshooting.

This manual should be read by those who design and maintain equipment that uses the SR series Hybrid Recorder. Be sure to keep this manual nearby for handy reference.

Azbil Corporation

Table of contents

1. Introduction	1
2. For Safe Use	4
2-1. Preconditions for Use	4
2-2. Symbol Mark	4
2-3. Label	4
2-4. Important Explanation	5
3. Model Code List	6
4. Mounting and Wiring	7
4-1. External Dimensions	7
4-2. Mounting	7
1. Panel cutout and mounting method	7
2. Mounting condition	8
4-3. Wiring	9
1. Terminal board diagram	9
2. Precautions on wiring	12
3. Power/protective conductor terminals wiring	14
4. Measurement input terminals wiring	15
5. Alarm output terminals wiring (option)	16
6. Remote contacts terminals wiring and operation selection (option)	19
7. Communication I/F terminal wiring (option)	21
5. Part Names	26
5-1. Front Section of Internal Unit	26
5-2. Operation/Set Keys	27
6. Operation	28
6-1. Preparation for Operation	28
6-2. Basic Operation	30
7. Inspection and Maintenance	33
7-1. Routine Inspection	33
7-2. Consumable Parts and Replacement Guideline	33
7-3. The battery removal method for the purpose of disposal	34

1. Introduction

Thank you for purchasing SR series with 100mm recording width.

This industrial use instrument records input signals to the chart paper and stores data into the SD card.

Mount this instrument on the indoor instrumentation panel etc. and record signals of temperature sensor, pressure gauge, hygrometer and flow meter. Reading signals of the recorder are thermocouple, resistance thermometer, DCmV and DCV.

Make sure to read this instruction manual in advance to understand this unit well and prevent troubles from occurring.

This manual is a "Wiring/Installation" Instruction manual.

Read the "General" Instruction manual from the CD-ROM provided when using the unit.

Request

- To the persons doing instrumentation, installation, and sales -

Make sure to provide this instruction manual to the person who uses the unit.

- To the users of this unit -

Store this instruction manual with care until you scrap the unit.

Also, write down the parameter contents set in the product and keep it for your record.

Product warranty scope

This product is warranted for one year from the date of delivery. If it is damaged during the warranty period, when used normally based on the cautions in the instruction manual labels attached to the product, etc., it will be repaired without any charge (only in Japan). In the case, we are sorry to trouble you, but please contact your dealer or nearest our sales office.

However, in cases of the followings, it will be repaired at your expense even during warranty period.

1. Failure or damage caused by improper use or connection, or invalid repair or modification.
2. Failure or damage caused by fire, earthquake, wind or flood, thunderbolt, or other extraordinary natural phenomena, or pollution, salt, harmful gas, abnormal voltage, or use of unspecified power.
3. Replacement of parts or accessories that have reached the end of their life.

Furthermore, the term 'warranty' in this sense covers only an Azbil's product itself. Therefore, we are not responsible for compensation for whatever the damage that is triggered by failure of our product.

Notice

1. No part of this manual can be reproduced or copied in any form without permission.
2. The contents of this manual may be altered without prior notice.
3. This manual has been documented by making assurance doubly sure. However, if any question arises or if any error, an omission, or other deficiencies are found, please contact your nearest our sales office.
4. Azbil is not responsible for any operation results of this software.

Trademark

1. Microsoft, Windows, Windows XP, Windows Vista, Windows 7, and NET Framework are trademarks of Microsoft Corporation and the related company.
2. SD Memory Card is the trademark of Panasonic Corporation, SanDisk Corporation in USA, and TOSHIBA CORPORATION.
3. Other described company names and product names are trademarks and registered products of the respective companies.
4. Please note that the marks "TM" and "®" are omitted throughout this manual.

Warning

Perchlorate Material

This instrument uses battery with Perchlorate Material.

Special handling may apply, see

<http://www.dtsc.ca.gov/hazardouswaste/perchlorate>

■ Before use

Make sure to check the following before use after unpacking the unit. If you have any question, please contact your dealer or our nearest office.

1. Exterior check

Check that the appearance of the product has no damage.

2. Model code check

Check that the model code of the purchased product is correct.

◆ Model code label and application place

The label as follows is attached on the upper surface of the product case and the chassis.

Model code → SR□□□□□□□□□□
Serial number→ Y4□□□□□□□□ CHINO
MADE IN JAPAN

3. Accessories check

Check the following accessories attached to the product.

Item	Qty	Remarks
Instruction manual	1	CD-R
Instruction manual [Wiring/Installation]	1	Booklet
Bracket	2 (1 set)	For panel mounting
Terminal screw	5	M3.5, for input terminal (spares for missing)
Chart paper	1	81406088-001.
Ribbon cassette	1	SR-921RC0000

In addition, if accessories are purchased additionally, those products may be attached.

Request

1. Do not drop the product while take it out of the box
2. When transporting the unit, pack in the dedicated package box, and put the box in an outer case with a bed of cushion.
With the consideration to the case above, it is recommended that the dedicated package box for the unit is stored.
3. When the unit is removed from the panel and not used for a long time, put it in the dedicated package box, and store it in a place with normal ambient temperature and less dust.

4. About attached chart paper

For the unit, the chart paper 81406088-001 (1 book) is available and attached. For the case that the chart paper is to be specified, various scales are available as follows.

Item	Item number	Printed scale (The following numbers are printed.)	Remarks
Folding chart 50 divisions	81406088-001	0,20,40,60,80,100	10 books 16m
Folding chart 40 divisions	81425048-004	0,10,20,30,40 0,20,40,60,80 0,50,100,150,200 The above 3 patterns are printed.	10 books 16m
Folding chart 50 divisions	81425048-001	0,10,20,30,40,50 0,20,40,60,80,100 0,40,80,120,160,200 The above 3 patterns are printed.	10 books 16m
Folding chart 60 divisions	81425048-002	0,10,20,30,40,50,60 0,20,40,60,80,100,120 0,50,100,150,200,250,300 The above 3 patterns are printed.	10 books 16m
Folding chart 70 divisions	81425048-003	0,2,4,6,8,10,12,14	10 books 16m
Folding chart 75 divisions	81425048-005	0,50,100,150	10 books 16m
Clean paper chart 50 divisions	81407115-001	0,20,40,60,80,100	10 books 12m

* The chart paper has the same printed linear scale as the standard scale.
Therefore, it can be shared in regardless of input types (thermocouple, resistance thermometer, or others).

5. Restriction of digital recording/printing function

- (1) Data printing requires approximately two minutes. Note that when data printing is executed, the trace printing stops until the printing is finished.
- (2) When the chart speed is set to 251mm/H or more, power-on printing, data printing, list printing, and printing function for other than time line are disabled.
- (3) The trace printing executes dot printing with five seconds interval (standard); however, if time printing is executed during the trace printing, the dot interval may become longer. The dot interval is extended with the inserted printing. Therefore, this is not abnormal.
- (4) Printing is formed with dots of one pin. Therefore, if the power is turned off while characters are being formed, they cannot be formed correctly. This is not abnormal.

6. Service parts

For the unit, service parts are available as follows.

Item	Item number	Remarks
Ribbon cassette	SR-921RC0000	
SD card	512MB	SR-911SD0512
	1GB	SR-911SD1000
	2GB	SR-911SD2000
250Ω resistor	Accuracy ±0.02%	81401325
	Accuracy ±0.05%	81446642-001

2. For Safe Use

If the unit is used in a manner not specified by manufacturer, the protection provided by the unit may be impaired.
For safe use of the unit, please read and understand the following cautions.

2-1. Preconditions for Use



The unit is a component type general product to be used mounted on an indoor instrumentation panel. Avoid using under other conditions.

Use after the system safety is implemented such as the fail-safe design and periodical inspection on the final product side. Also, for wiring/adjustment/operation of the unit, ask professionals with instrumentation knowledge to perform.

Furthermore, also the person who actually uses the unit is required to read this instruction manual to fully understand various cautions.



2-2. Symbol Mark

This instruction manual includes the following symbol marks. Make sure to fully understand the meaning of them.

Symbol mark	Meaning
 Warning	Cautions are explained to avoid causes for death or serious injuries of users.
 Caution	Cautions are explained to avoid causes for slight injuries of users or damages of the unit or peripheral devices.

2-3. Label

For safe use of the unit, the following labels are used.

Label	"Name" and place	Meaning
	"Alert symbol mark" Various terminals (back side)	Place to be handled with cautions to avoid "electric shock", "injuries", etc.
	"Protective conductor terminal" Right side of power terminal (back side)	Terminal to be grounded to avoid electric shock
100 to 240V AC 50/60Hz, 40VA	"Power source specification" Power conductor terminals	Specification of power (voltage range, frequency, and power consumption) used for the unit

2-4. Important Explanation



Warning

To avoid severe accidents, make sure to read and understand the following.

1. Switch and overcurrent protection device

This unit is not provided with a replaceable overcurrent protective device. Prepare a switch and an overcurrent protective device for the power supply (circuit breakers, circuit protectors or the like) within 3m of this unit in a location where the operator can access easily. Use a switch and an overcurrent protective device conforming to IEC947-1 and IEC947-3.

2. Be sure to ground this instrument

To avoid electric shock, before turning the power on, connect the protective conductor terminal of this recorder to the protective conductor of the power supply equipment, and do not remove it during use.

3. Before turning on the power supply

For safety, first check that the power source is within the range indicated on the power label, and then turn on the external power switch.

4. Avoid repair and modification

Avoid repair and modification with parts replacement by persons other than service personnel authorized by Azbil. Not only damage or malfunction of this recorder may occur, but also dangers such as electric shock may occur. In addition, the inner unit does not have to be pulled out in the normal use.

5. Use the unit following the instruction manual

For safe use, use the unit following the instruction manual. Please note that Azbil does not have any responsibilities for any claims for failures or damages occurred with abuse or misuse of this recorder.

6. Installing the safety device

Regarding the use of a device that anticipates a big loss due to failure of the controller and the peripheral device, always install a safety device for preventing these losses and implement fail safe design in the final product. Do not use it in important facilities like, human life, atomic energy, aviation and space.

7. Turn off the power supply if abnormality occurs

Turn off the power supply immediately and contact your local Azbil's sales office if any abnormal odor, noise or any smoke occurs, or if this unit becomes high temperature that is too hot to be touched.

8. Do not put hands in this product

Do not put your hands or tools inside of this product. It may cause electric shock or injuries. There is no operation such as pulling out an inner unit or using tools when using this product.

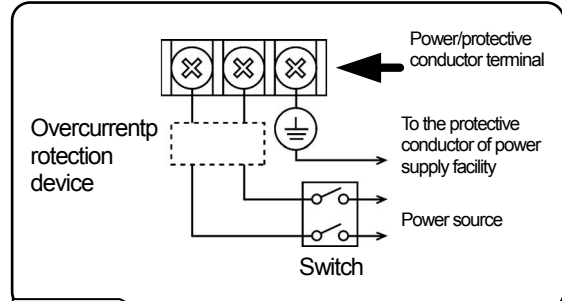

Reference Fuse in power unit

For safety, the fuse below is included in the power unit of the unit. It cannot be replaced.

Manufacturer: Daito Communication Apparatus Co., Ltd
Model: SBL32

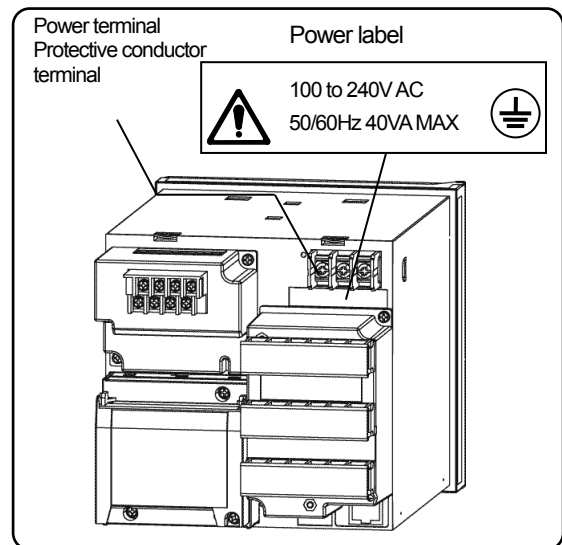

3. Model Code List

SR-1□□□□□NN□

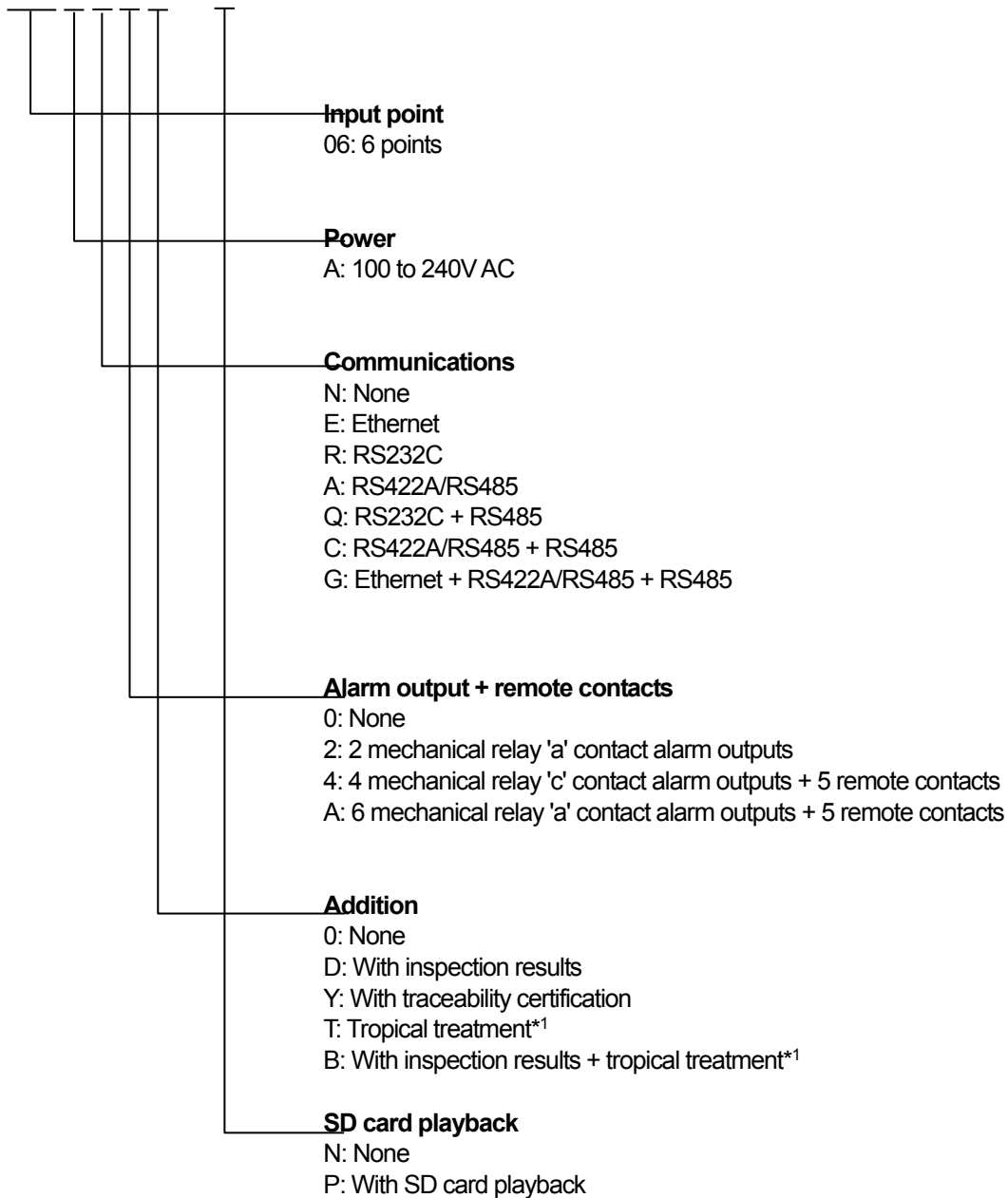

*¹ Tropical treatment does not comply with the CE marking.

4. Mounting and Wiring

4-1. External Dimensions

Following dimensions are measured while the brackets are attached to the unit.

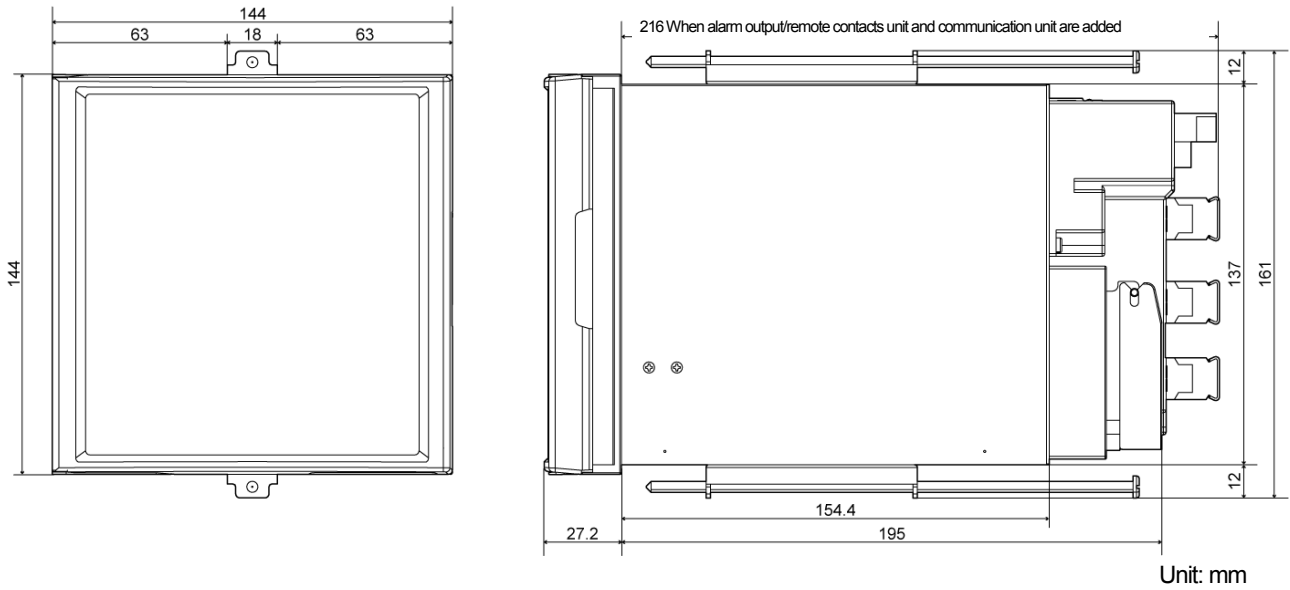

4-2. Mounting



Caution

- (1) Use the recorder mounting on an indoor installed instrumentation panel.
- (2) Brackets can be attached to a panel of steel with thickness of 2 to 6mm or equivalent strength. Select thickness of a panel considering weight and depth of the unit with panel formation for actual use.
- (3) For mounting the recorder on the panel, be careful of injury by dropping it.

1. Panel cutout and mounting method

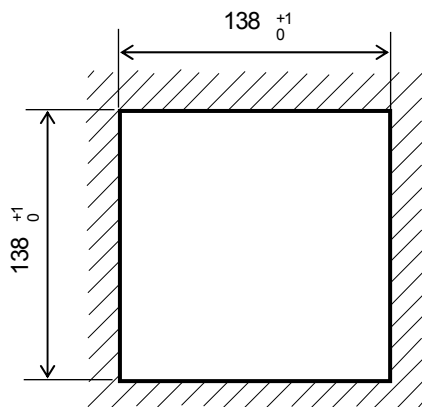

- Minimum interval on multiple units mounting

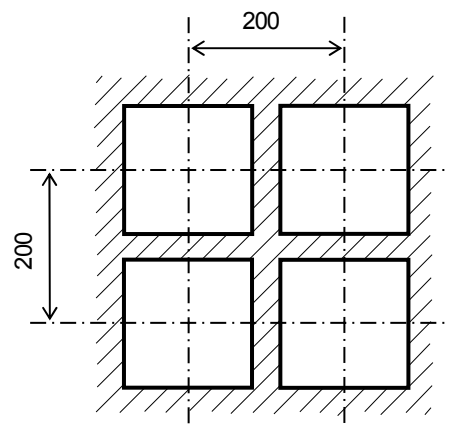

Unit: mm

- (1) Insert the unit into the panel cutout from the front of the panel.
- (2) Fix the unit to the panel using the brackets (tightening torque: 1.0Nm). Brackets are attached to the top and bottom surfaces.

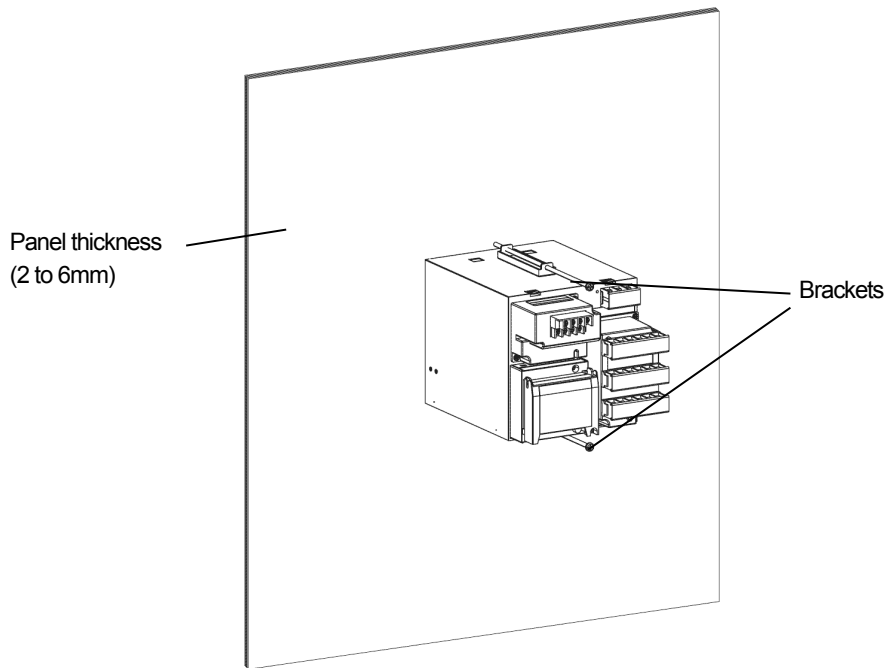

2. Mounting condition



Caution

To avoid accidents, make sure to read and understand the following.

Industrial environment

Select a location distant from sources of electric field or magnetic field and without mechanical vibration or shock.

- Overvoltage category II (EN standard)
- Altitude 2000m or less
- Pollution degree 2 (EN standard)
- Working place Indoor

Normal operating condition

- Ambient temperature 0 to 50°C (20 to 65%RH, non-condensing)
- Ambient humidity 20 to 80%RH, non-condensing (5 to 45°C)
- Power voltage General specification : 100 to 240V AC $\pm 10\%$
- Power frequency General specification : 50/60Hz $\pm 2\%$

Atmosphere

- For safety, avoid a location with corrosive gas, explosive gas, flammable gas and combustible gas.
- Avoid a location with dust, smoke, or steam.

Mounting angle

- Lateral tilting 0 to 10°
- Longitudinal tilting Forward tilting: 0° Backward tilting: 0 to 30°
- View angle -10 to +30° with the horizon as the standard

Angles other than the above affect the recording operation.

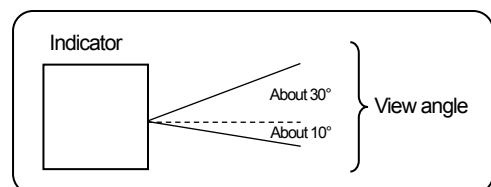

4-3. Wiring

1. Terminal board diagram

The figure below is the diagram of the terminal board with the option [Alarm relay output (6 points 'a' contact) + remote contacts and communication interface].

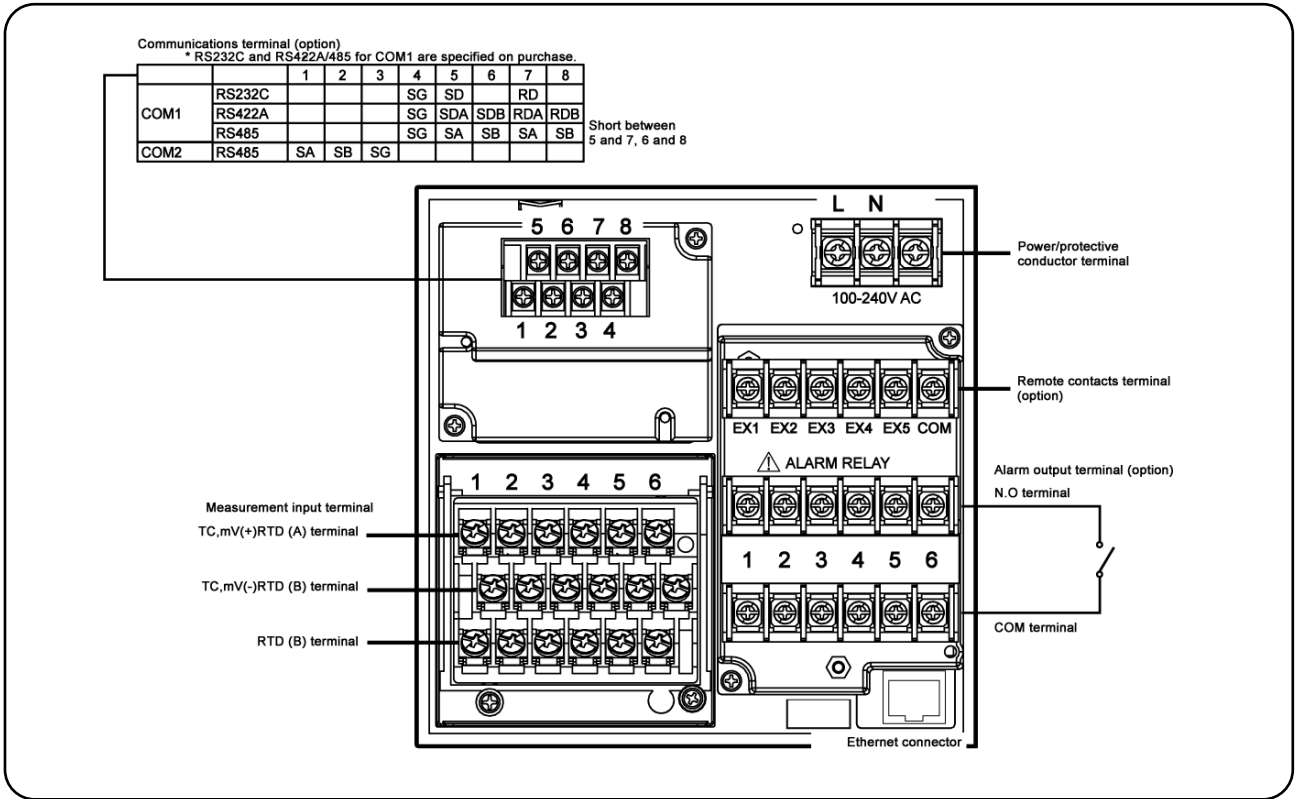

The figure below is the diagram of the terminal board with the option [Alarm relay output (4 points 'c' contact) + remote contacts and communication interface].

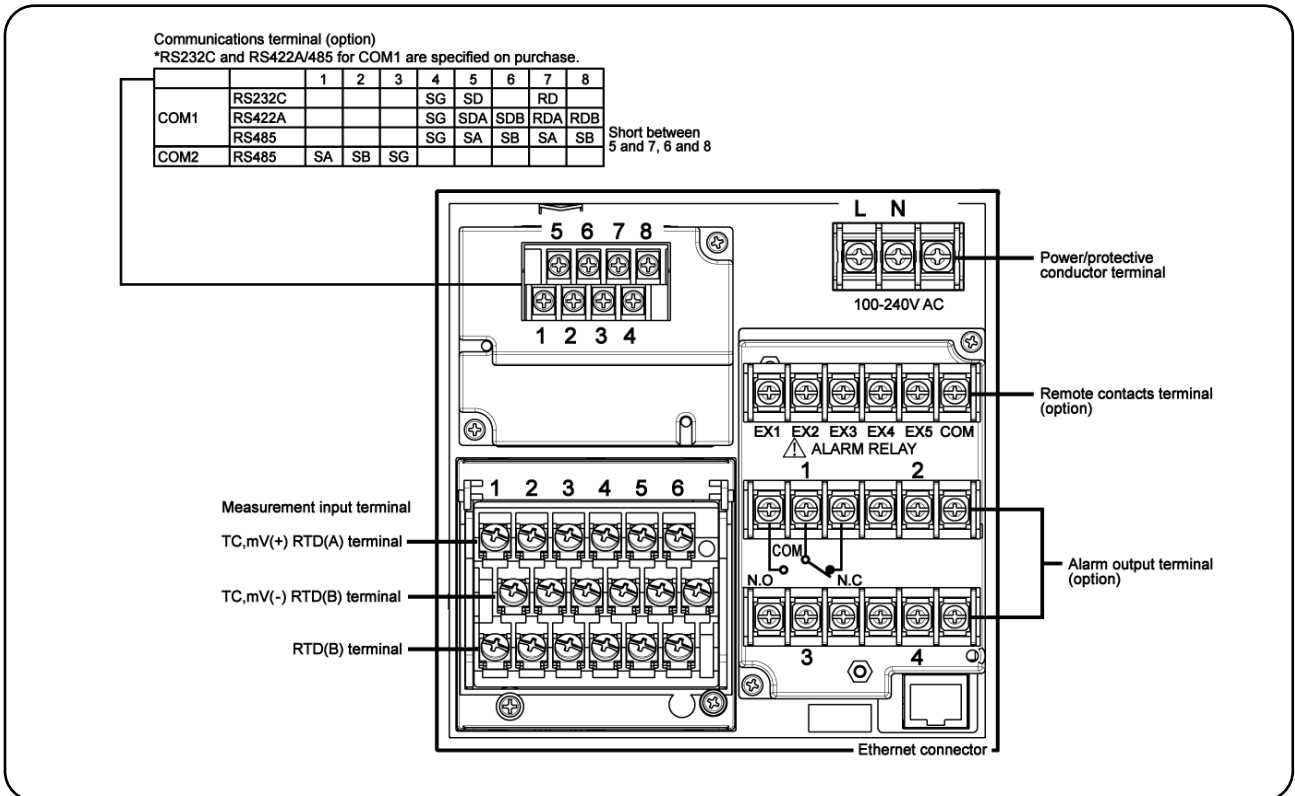

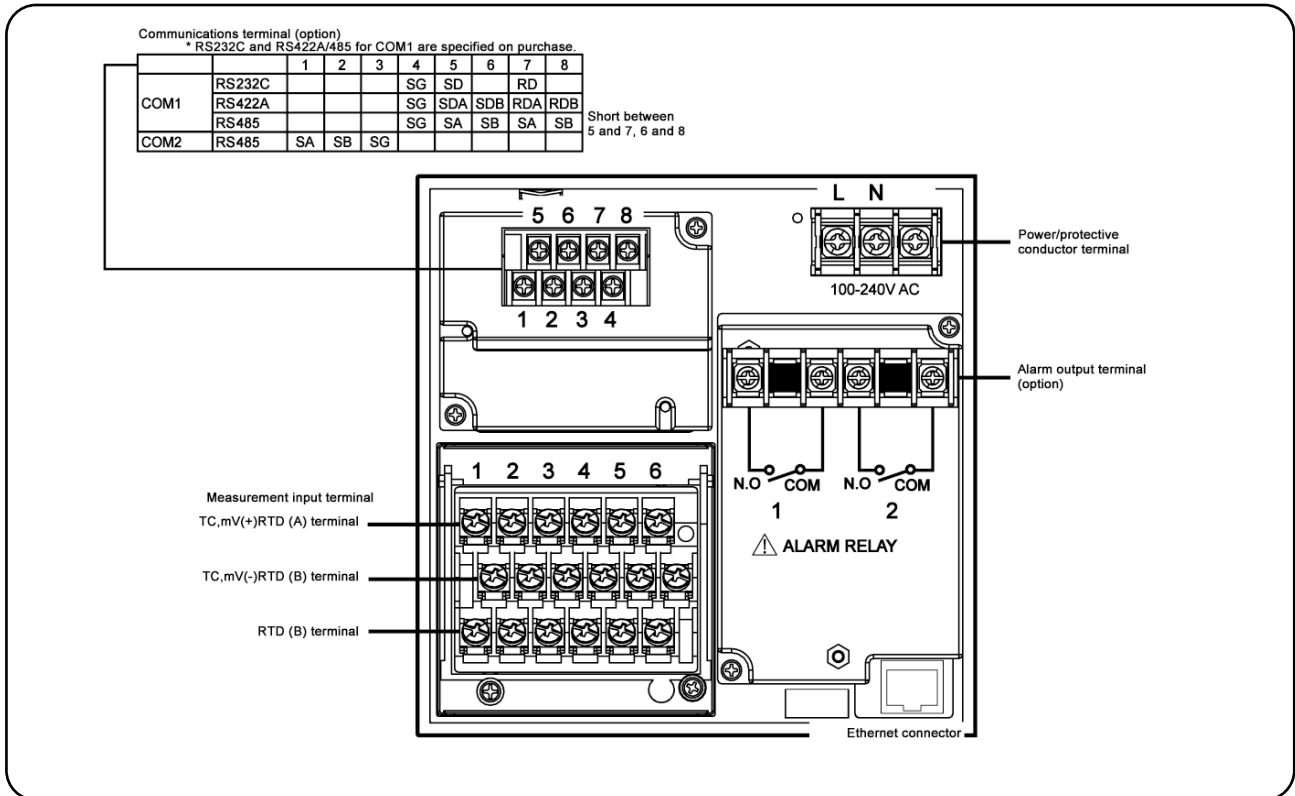

The figure below is the diagram of the terminal board with the option [Alarm relay output (2 points 'a' contact) and communication interface].





Warning

■ Alert symbol mark () and location

 mark is attached to the location to which if human body touches, an electric shock may be generated.

Terminal name	Location of attached mark
Power terminal	Lower left of power terminal
Measurement input terminal	Upper left of terminal cover
Mechanical relay 'c' contact alarm terminal	Upper left of terminal cover
Mechanical relay 'a' contact alarm terminal	Lower left of N.O terminal

Reference **Input terminal block and alarm terminal block are removable.**

For easy wiring, the input unit, alarm output/remote contacts unit, and communication unit are removable.

- (1) Every unit can be removed when two mounting screws are removed.
- (2) The recorder and each unit are connected with a connector.

[Input unit]

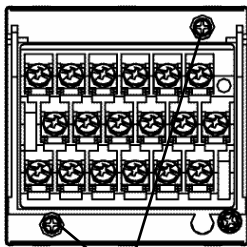

Mounting screws

[Alarm output/remote contacts unit]

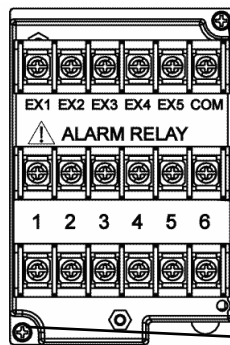

Mounting screws

[Communications unit]

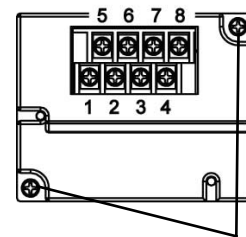

Mounting screws



Warning

■ **Turn off the power and then remove/attach**

Make sure to turn off the external power switch before units are removed/attached to prevent damages on electric circuits.

Note **Thermocouple input unit replacement**

Only thermocouple input unit cannot be replaced with other instrument unit. If done so, measurement errors are generated.

2. Precautions on wiring

Precautions on wiring are described below. Observe them to maintain safety and reliability.

1) Feed power source

For the power source for the unit, use the single-phase power source with stable voltage and without waveform strain to prevent malfunctions.

 Warning	<p>(1) Switch and overcurrent protective device Add a switch and overcurrent protective device (250V,3A) to the feed power source to prevent an electric shock on wiring. The unit has no replaceable fuse.</p> <p>(2) Connect after the power source is turned OFF When performing power and input/output wiring, make sure to turn OFF the feed power source to prevent an electric shock.</p>
--	--

2) Separate from strong power circuits

For input/output wiring, avoid adjacency or parallel with strong power circuits such as power lines. Separate 50cm or more for adjacency or parallel.

3) Separate thermocouple input from heat sources.

To reduce reference junction compensation errors for thermocouple input, especially separate terminals from heat sources (heating body). Also, avoid radiation such as direct sunlight.

4) Separate from noise sources.

Separate from noise sources as much as possible. Unexpected troubles may occur. If separation from noise sources is disabled, implement countermeasures.

Main source	Countermeasures
<ul style="list-style-type: none"> • Electromagnetic switch or others • Power line with distortion of wave • Inverter • Thyristor regulator 	<p>Insert noise filters between power source and input/output terminals. CR filters are used in many cases.</p>

- 5) Use crimping terminals.
- (1) To prevent looseness or disconnection of terminals and short circuit between terminals, install crimping terminals to termination of connection cables.
 - (2) To prevent an electric shock, use crimping terminals with insulation sleeves.

Terminal Type and Termination Treatment

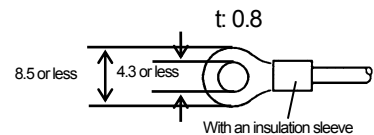
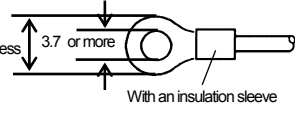
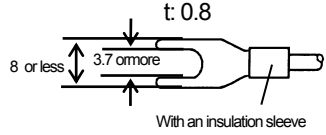
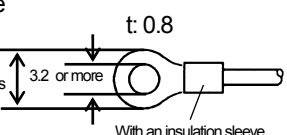
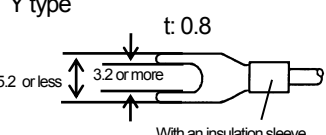
Terminal board	Diameter	Tightening torque	Termination treatment (Unit: mm)
Power/Protective conductor	M4	1.2Nm	<p>O type</p> 
Terminals other than the above	M3.5	0.8Nm	<p>O type</p>  <p>Y type</p>  <p>* Be sure to use O type for the alarm output terminals. * For other terminals, use also O type as possible.</p>
Communications terminal	M3	0.5Nm	<p>O type</p>  <p>Y type</p>  <p>* Use O type as possible.</p>

- 6) Unused terminals
Avoid using unused terminals for relaying. Electric circuits may be damaged.

 <p>Warning</p>	<p>■ Treat properly the wired cables. Treat surely wired cables not to get hung up on people and things. Disconnection of wiring with hanging up may cause an electric shock.</p>
---	--

3. Power/protective conductor terminals wiring

1) Power/protective conductor terminals

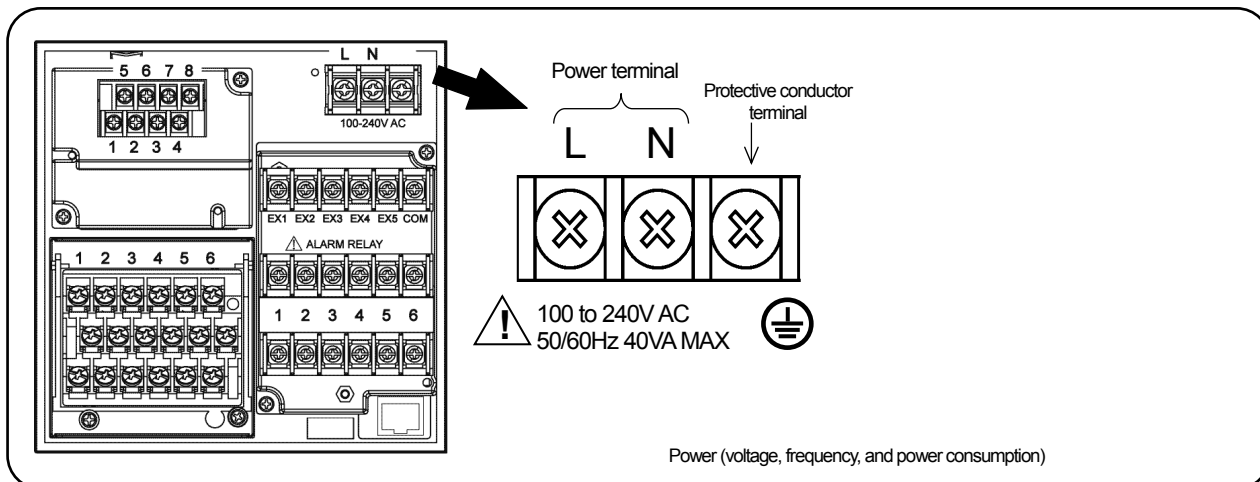

Warning

■ Turn OFF feed power source.

Before power/protective conductor terminals wiring, make sure to turn off the feed power source to prevent an electric shock.

2) Power terminal wiring

Using 600V vinyl insulated cables as the power line, install crimping terminals with insulation sleeves to the termination for wiring.

Note: Use the following standard cables.

- (1) IEC 60227-3
- (2) ANSI/UL817
- (3) CSA C22.2 No.21/49

Note L/N display of power terminal

Display based on CSA standard in Canada. The live side of single-phase AC power supply is L, and the neutral side is N display. To get sufficient performance, observe the L/N wiring.

3) Protective conductor terminal wiring

Make sure to connect to the protective conductor of the power equipment. Install crimping terminals with insulation sleeves for wiring.

- Grounding wire: Copper cable with wire diameter 2mm² or more (green/yellow)

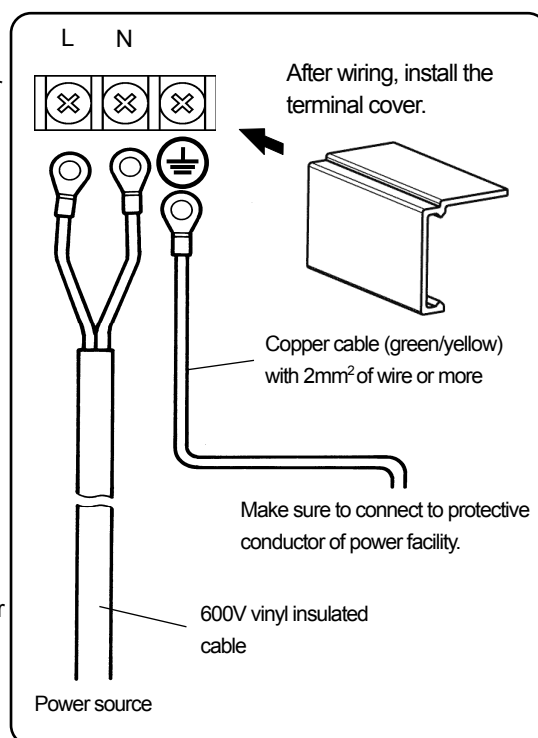

Caution

■ ⚠ mark at power terminals

After wiring the power terminals have power supply voltage applied. Make sure to install power terminal covers after wiring to prevent an electric shock.



Warning

■ Pay attention to power supply voltage and noise.

The power supply voltage of the unit is indicated on power terminals. Applying power other than the indicated one causes accidents or malfunction. In addition, if the power has noise interference, implement countermeasures such as noise cut transformer installation.

4. Measurement input terminals wiring

- 1) Measurement input terminal
Turn OFF the feed power source before wiring to prevent an electric shock.
Install crimping terminals with insulation sleeves to input terminals for wiring.
- 2) DC voltage (current) input wiring
Use instrumentation twisted cables for measures against noise as input cables.
For current input, connect the shunt resistor for current input to the channel to be measured before wiring.

Note Measurement input termination

TC,mV(+) and RTD(A) terminals and TC,mV(-) and RTD (B "middle") terminals are insulated for each channel, and RTD (B "lower") terminal shorts internally between channels.

- 3) Thermocouple (TC) input wiring
Make sure to wire thermocouple cable (or compensation lead wire) to input terminals of the unit.
If a copper conductive wire is connected halfway, big measurement error will be generated.
In addition, avoid parallel connection of a pair of thermocouple wires with other instruments (controller or others) that causes troubles.
- 4) Resistance thermometer (RTD) input wiring
To prevent measurement errors, use 3-core cables as the input cable in which lines have the same resistance.
In addition, one resistance thermometer cannot be connected in parallel with other instruments (a controller or others).

⚠ Caution

■ Allowable input voltage

Input type	Allowable input voltage
Voltage, thermocouple input	±10VDC *
Resistance thermometer input	±6VDC

*±60VDC for channels specified with ±10V range or more

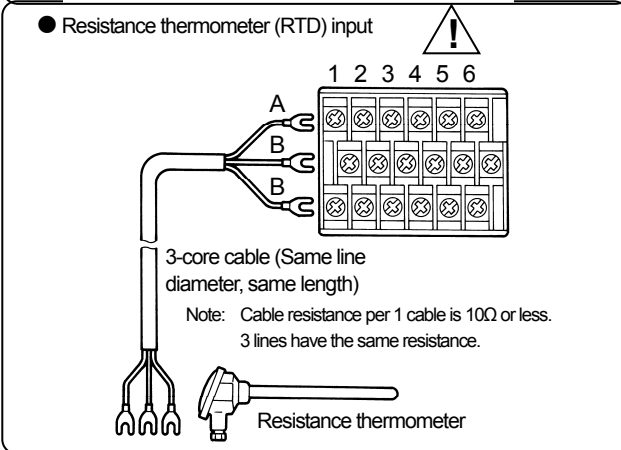
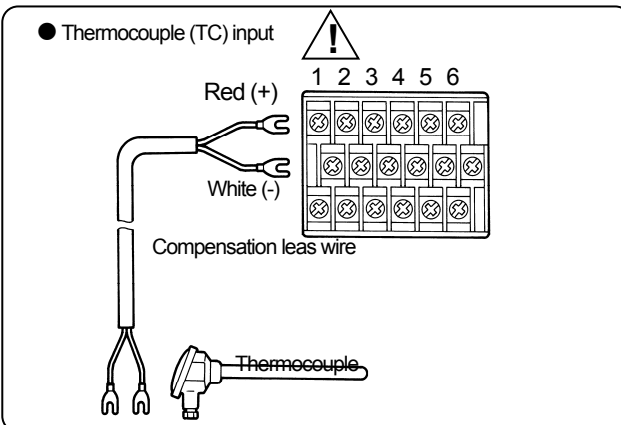
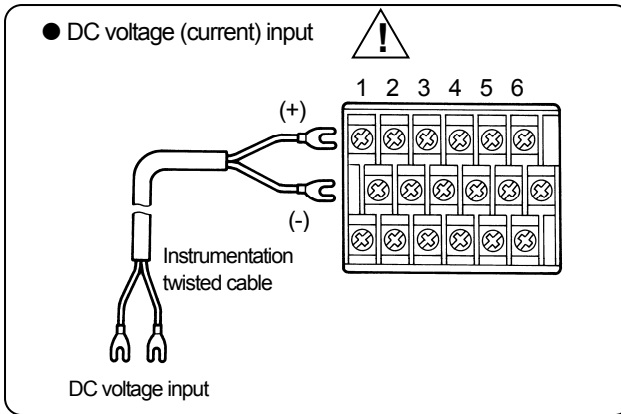

Warning

■ **⚠ mark on measurement input terminals**

High voltage may be applied to the measurement input terminals due to common mode noise. Allowable noise value is 30VAC or 60VDC or less. Check that the voltage is equal to or less than the allowable value. Install terminal covers after wiring to prevent an electric shock and protect input cables. For thermocouple input, installing terminal covers reduces reference junction compensation errors.

- 5) Input unit terminal cover mounting/removing
- (1) Raise the cover to the direction of the arrow.
 - (2) Turn to the direction of the arrow.
 - (3) Pull it to the direction of the arrow to remove.

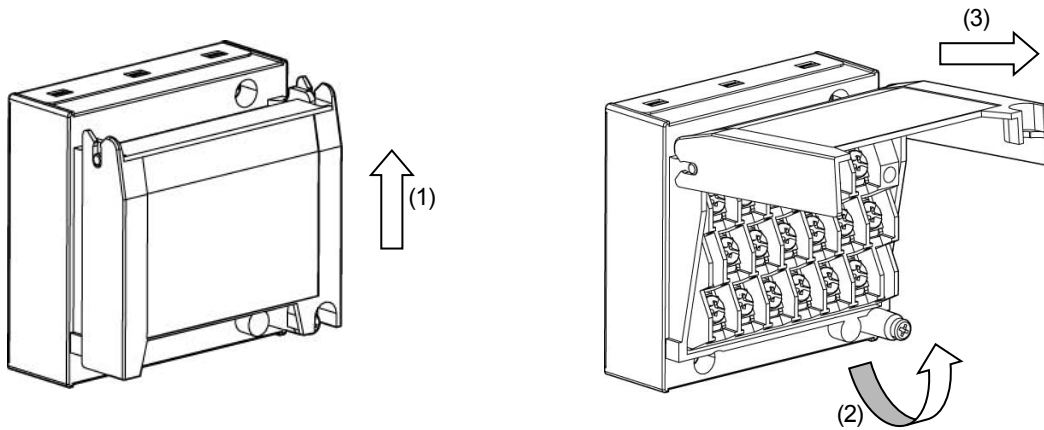

5. Alarm output terminals wiring (option)

- 1) Alarm output terminals
The terminal configuration depends on the output specification.

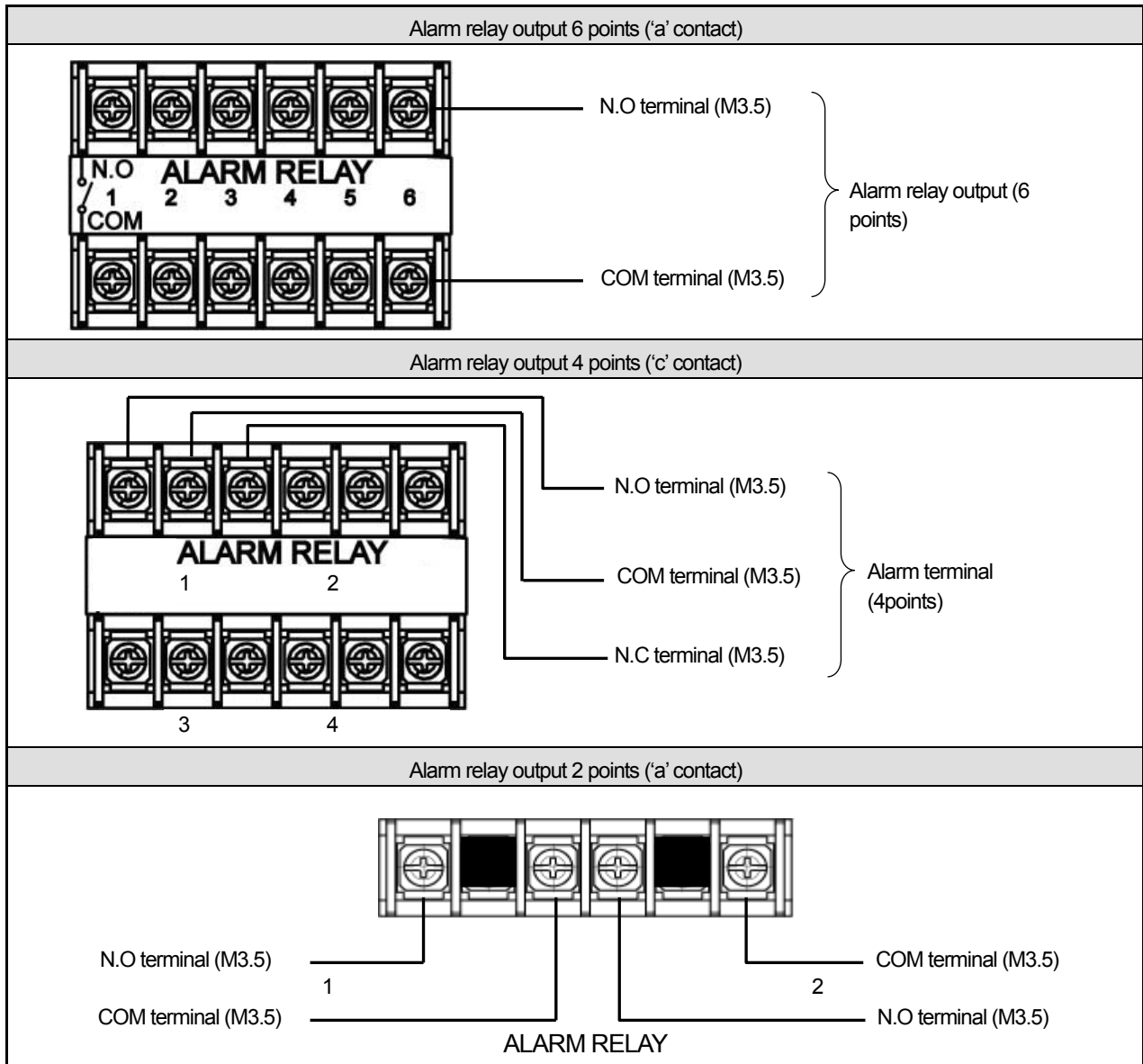

2) Wiring

Turn OFF the feed power source and the power source for buffer relay before wiring to prevent an electric shock.

- (1) Wire the cable to the load via the buffer relay.
- (2) To the alarm output terminals, type O crimp style terminal with insulation sleeve which is connected to double insulated signal wire should be connected. (Refer to 4-3. Wiring, 2. Precautions on wiring)

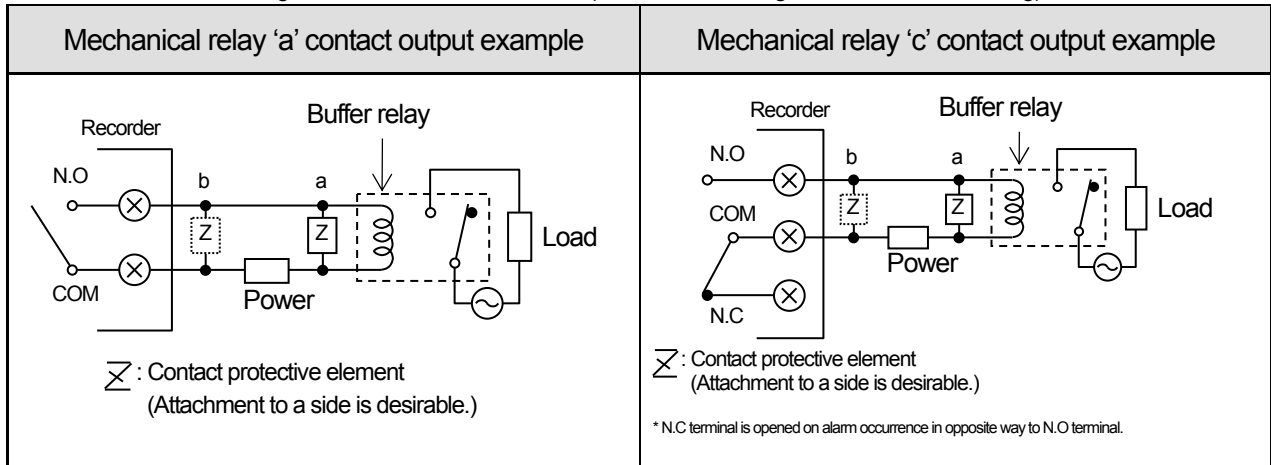

Warning

■ **⚠ mark on alarm output terminals**
 Maximum of 240VAC can be connected to the alarm output terminals of this unit.
 Basic insulation (dielectric strength 1390V) is carried out between the alarm output channels, however, from the malfunction etc. 240VAC may be output to each alarm output terminals. Double insulation or reinforced insulation to the outside circuit connected to an alarm output terminal should be set.

※Basic insulation between output channels

A buffer relay power supply is applied to the alarm output terminals after connections and so creates a risk of electric shock if touched. Terminal cover must be mounted after connection. Moreover, safety measures to the outside circuit should be set.

Caution

■ **Implement safety measures.**
 The alarm output of the unit may generate output failure with wrong operation, failure, abnormal input, or others. Double insulation or reinforced insulation in outside circuit side of all the channels should be set in any system for safety ensuring.

3) Precautions on wiring

The following are precautions on wiring.

Item	Description														
Mechanical relay output specification contact capacity (Common to 'a' contact and 'c' contact)	<table border="1" data-bbox="507 235 1177 376"> <thead> <tr> <th data-bbox="507 235 727 268">Power supply</th> <th data-bbox="727 235 951 268">Resistance load</th> <th data-bbox="951 235 1177 268">Inductive load</th> </tr> </thead> <tbody> <tr> <td data-bbox="507 268 727 302">100VAC</td> <td data-bbox="727 268 951 302">2A</td> <td data-bbox="951 268 1177 302">1A</td> </tr> <tr> <td data-bbox="507 302 727 336">240VAC</td> <td data-bbox="727 302 951 336">2A</td> <td data-bbox="951 302 1177 336">1A</td> </tr> <tr> <td data-bbox="507 336 727 376">30VDC</td> <td data-bbox="727 336 951 376">2A</td> <td data-bbox="951 336 1177 376">1A</td> </tr> </tbody> </table> <p data-bbox="1236 268 1426 336">(Minimum load) 100μA100mVDC</p>			Power supply	Resistance load	Inductive load	100VAC	2A	1A	240VAC	2A	1A	30VDC	2A	1A
Power supply	Resistance load	Inductive load													
100VAC	2A	1A													
240VAC	2A	1A													
30VDC	2A	1A													
Contact protective element Z installation	<ul style="list-style-type: none"> ● Install the contact protective element which fits the buffer relay. ● It is effective to install the element to the coil side of the buffer relay (see the figure of mechanical relay 'a' contact output example) and prevents wrong operation with light load. 														
Selection of buffer relay	<ul style="list-style-type: none"> ● Coil rating: Contact capacity or less of output terminals ● Contact rating: Double of load current or more <p>In addition, the coil surge absorption element built-in type relay is recommended. If there is no buffer relay which meets the load rating, implement another stage of buffer relay.</p>														
Selection of contact protective element	<p>If there is no surge absorption element built-in buffer relay, install this element. The element of C/R (capacitor + resistor) is general. <C/R standard> C: 0.01μF (Rating about 1kv) R: 100 to 150Ω (Rating about 1W)</p>														

6. Remote contacts terminals wiring and operation selection (option)

Only with remote contacts terminals (option).

1) Remote contacts terminals

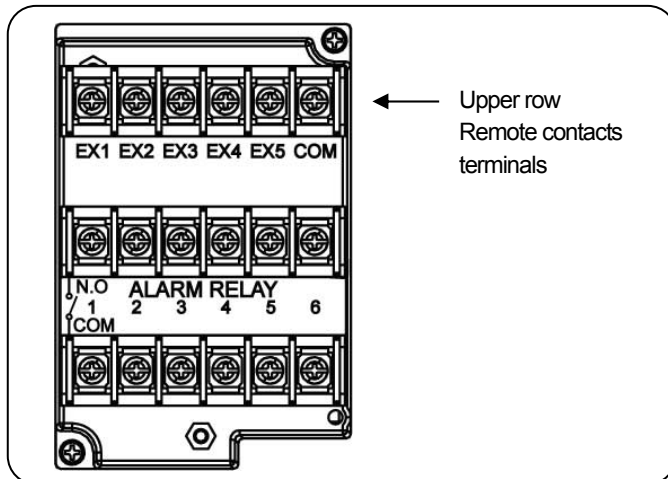

Note Characteristics of contact input terminals

- Voltage on contact open: About 5V
- Current on contact short: About 10mA

2) Wiring

Turn OFF the feed power source before wiring to prevent an electric shock.

- (1) Use no voltage contact signals to be given to the remote contacts terminals.
- (2) Install crimping terminals with insulation sleeves to remote contacts terminals for wiring.

■ Wiring example

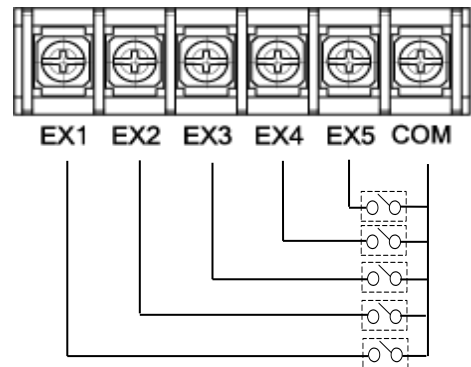

Warning

■ No voltage contact

For contacts connected to the remote contacts terminals, use switches or relays driven with voltage level 30VAC or 60VDC or less or manual contacts which support light load.

Reference Remote contact

- Remote contact enabled operation name
 - (1) Recording ON/OFF and three chart speed selection (two terminals of EX1 and EX2 are used)
 - (2) Messages (No. 01 and 02) selection and printing execution (two terminals of EX1 and EX2 are used)
 - (3) Messages (No. 01 to 05) selection and execution (four terminals of EX1 to EX4 are used)
 - (4) Digital data printing (arbitrary one terminal)
 - (5) List printing (No. 1 to 3) (arbitrary one terminal for each)
 - (6) Integration reset (arbitrary one terminal)
 - (7) Messages No. 01 to 20 printing execution (each arbitrary one terminal)
 - (8) Time correction execution (arbitrary one terminal)

Each function requires short-circuit for one second or more between COM terminal and each terminal.
- Operation allocation

Setting of allocation of operations to each terminal (EX1 to EX5) is required.
- Name of operations which require setting
 - (1) Recording ON/OFF and three chart speed selection (See general 8-7. Chart Speed Settings.)
 - (2) Message selection and printing execution (See general 8-14. Message Printing 1 Settings.)

3) Operation for which terminal No. is decided automatically

ON: Short-circuit OFF: Open

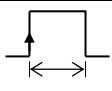
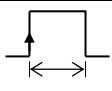
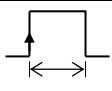
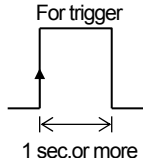
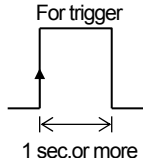
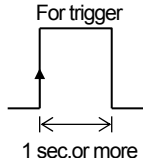
Operation name	Terminal contact signal																															
(1) 3 chart speed selection	<p>3 chart speed setting other than the setting here is required. (See general 8-7. Chart Speed Settings.)</p> <table border="1"> <thead> <tr> <th colspan="2" rowspan="2">Recording ON/OFF and 3 chart speed selection</th> <th colspan="2">Between COM and EX□ terminals</th> </tr> <tr> <th>EX1</th> <th>EX2</th> </tr> </thead> <tbody> <tr> <td rowspan="3">Recording ON</td> <td>CS1</td> <td>OFF</td> <td>OFF</td> </tr> <tr> <td>CS2</td> <td>ON</td> <td>OFF</td> </tr> <tr> <td>CS3</td> <td>OFF</td> <td>ON</td> </tr> <tr> <td colspan="2">Recording OFF</td> <td>ON</td> <td>ON</td> </tr> </tbody> </table> <p>Chart recording must be ON.</p>	Recording ON/OFF and 3 chart speed selection		Between COM and EX□ terminals		EX1	EX2	Recording ON	CS1	OFF	OFF	CS2	ON	OFF	CS3	OFF	ON	Recording OFF		ON	ON											
Recording ON/OFF and 3 chart speed selection				Between COM and EX□ terminals																												
		EX1	EX2																													
Recording ON	CS1	OFF	OFF																													
	CS2	ON	OFF																													
	CS3	OFF	ON																													
Recording OFF		ON	ON																													
(2) Message printing (No.01 and 02)	<p>Message setting other than the setting here is required. (See general 8-14. Message Printing 1 Settings.)</p> <table border="1"> <thead> <tr> <th>Message No. 01</th> <th>COM and EX1</th> <th rowspan="2">For trigger 1 sec.or more</th> <th rowspan="2"></th> </tr> </thead> <tbody> <tr> <td>Message No. 02</td> <td>COM and EX2</td> </tr> </tbody> </table> <p>At the point when the trigger signals (1 second or more) are given, the selected message is printed. Message printing with key is available.</p>	Message No. 01	COM and EX1	For trigger 1 sec.or more		Message No. 02	COM and EX2																									
Message No. 01	COM and EX1	For trigger 1 sec.or more																														
Message No. 02	COM and EX2																															
(3) Message printing (No. 01 to 05)	<p>Message setting other than the setting here is required. (See general 8-14. Message Printing 1 Settings.)</p> <table border="1"> <thead> <tr> <th rowspan="2">Message</th> <th colspan="4">Between COM and EX□ terminals</th> <th rowspan="2">For trigger 1 sec.or more</th> </tr> <tr> <th>EX1</th> <th>EX2</th> <th>EX3</th> <th>EX4 *</th> </tr> </thead> <tbody> <tr> <td>No.01</td> <td>OFF</td> <td>OFF</td> <td>OFF</td> <td rowspan="5"></td> </tr> <tr> <td>No.02</td> <td>ON</td> <td>OFF</td> <td>OFF</td> </tr> <tr> <td>No.03</td> <td>OFF</td> <td>ON</td> <td>OFF</td> </tr> <tr> <td>No.04</td> <td>ON</td> <td>ON</td> <td>OFF</td> </tr> <tr> <td>No.05</td> <td>OFF</td> <td>OFF</td> <td>ON</td> </tr> </tbody> </table> <p>* After message No. is selected, when the trigger signals (1 second or more) are given, the selected message is printed. Chart recording must be ON. Message printing with key is available.</p>	Message	Between COM and EX□ terminals				For trigger 1 sec.or more	EX1	EX2	EX3	EX4 *	No.01	OFF	OFF	OFF		No.02	ON	OFF	OFF	No.03	OFF	ON	OFF	No.04	ON	ON	OFF	No.05	OFF	OFF	ON
Message	Between COM and EX□ terminals				For trigger 1 sec.or more																											
	EX1	EX2	EX3	EX4 *																												
No.01	OFF	OFF	OFF																													
No.02	ON	OFF	OFF																													
No.03	OFF	ON	OFF																													
No.04	ON	ON	OFF																													
No.05	OFF	OFF	ON																													

4) Operation which can be allocated to arbitrary terminal No.

ON: Short-circuit OFF: Open

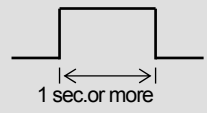
Operation name	Terminal contact signal
(4) Digital data printing	<p>Turn ON the terminal No. specified to "Digital data printing." Chart recording must be ON. Digital data printing with key is enabled. Even during execution, the acceptance can be repeated only once.</p> 
(5) List printing (List No.1, 2, and 3)	<p>Turn ON the terminal No. specified to "List 1, List 2, or List 3 printing." Chart recording must be ON. List printing with key is available. (See general 8-13. List Printing Settings)</p>
(6) Integration reset	<p>When "Collective reset with remote contacts (EX)" is selected with "Calculation programming", turning ON the terminal No. specified to "Integration reset" resets the integration value. (See general 8-4. Calculation Settings.)</p>
(7) Message printing (No.01 to No.20)	<p>Message setting other than the setting here is required. (See general 8-14. Message Printing 1 Settings.) Turn ON the terminal No. specified to "Message printing (No. 01 to 20)." Chart recording must be ON. Message printing with key is available.</p>
(8) Time correction	<p>When the current time (second) is within 0 to 30 seconds, the time is corrected to zero seconds by dropping the seconds. When it is within 31 to 59 seconds, the time is put forward one minute by rounding up and corrected to zero seconds.</p>

7. Communication I/F terminal wiring (option)

SR can be connected for communications with RS232C, RS422A, RS485, and Ethernet.

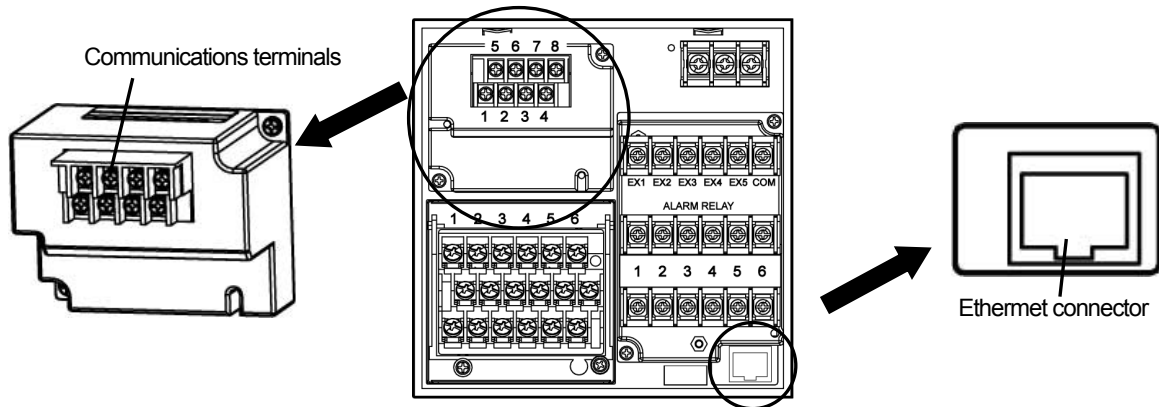

1) Communications terminal type (option)

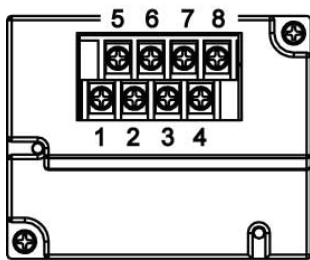

		1	2	3	4	5	6	7	8
COM1	RS232C *				SG	SD		RD	
	RS422A *				SG	SDA	SDB	RDA	RDB
	RS485 *				SG	SA	SB	Short with SA	Short with SB
COM2	RS485	SA	SB	SG					

* RS232C and RS422A/485 of COM1 are to be specified on purchase.

2) Communications cables

Please prepare communication cables before wiring in advance.
Since exclusive cables are available from us, place an order.

(1) RS232C

Connection between PC and the unit or a line converter

Cable	9-pin connector ↔ Crimp type ring terminals RS232C cable
Shape	
Internal wiring	

(2) RS422A

Connection between a line converter and the unit

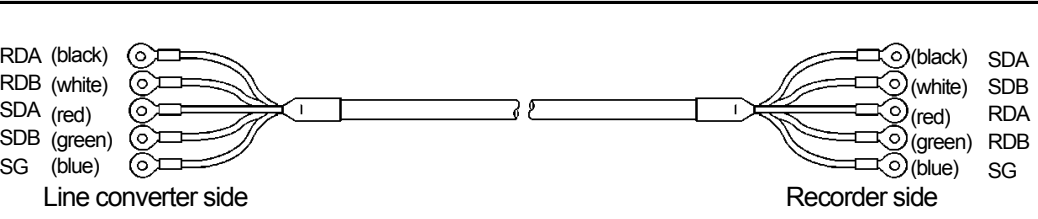
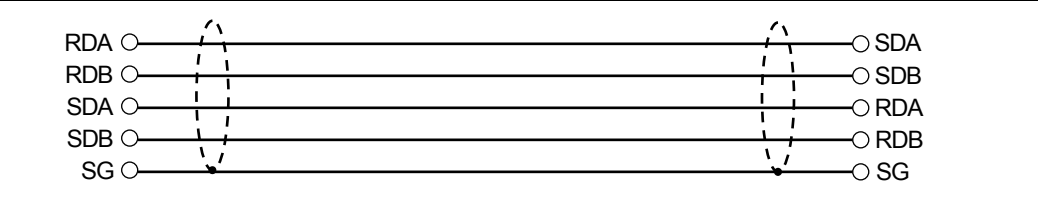
Cable	Crimp type ring terminals ↔ Crimp type ring terminals RS422A cable (for a line converter)
Shape	 <p>4-core cable of twisted 2-core cables of twisted VCTF lines. Each side has a SG (signal ground) line. Since the line converter has no SG terminal, cut and use the cable.</p>
Internal wiring	

Connection between the unit and other devices

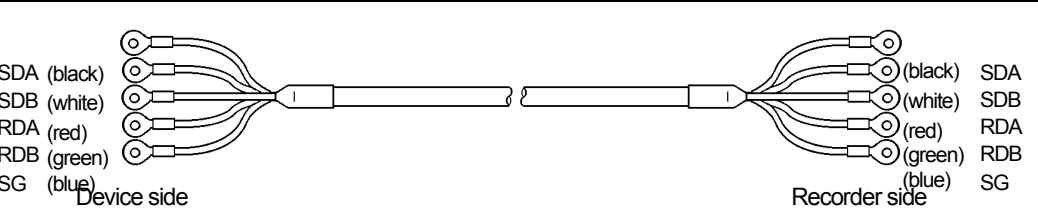
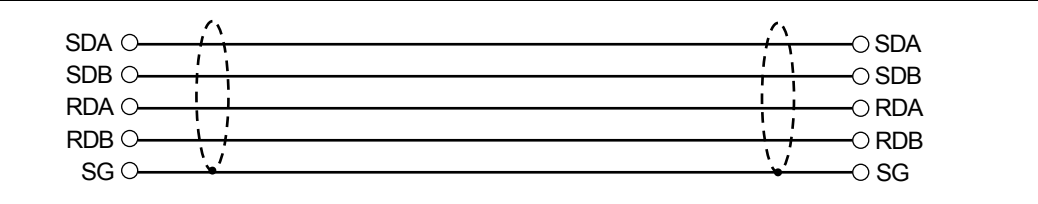
Cable	Crimp type ring terminals ↔ Crimp type ring terminals RS422A cable (for parallel)
Shape	 <p>4-core cable of twisted 2-core cables of twisted VCTF lines. Each side has a SG (signal ground) line.</p>
Internal wiring	

(3) RS485

Connection between the unit and other devices and between a line converter and the unit

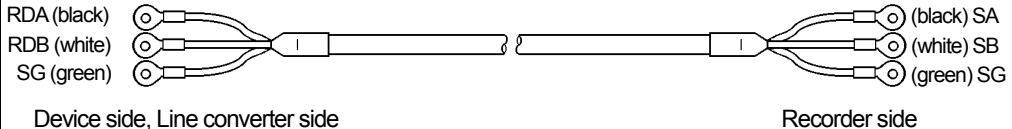
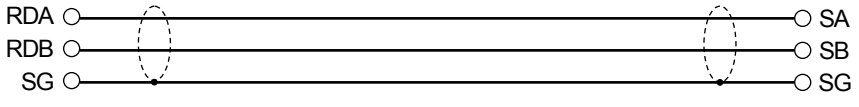
Cable	Crimp type ring terminals ↔ Crimp type ring terminals RS485 cable
Shape	 <p>Device side, Line converter side</p> <p>Recorder side</p> <p>2-core cable of twisted CVVS lines. Each side has a SG (signal ground) line. Since the line converter has no SG terminal, cut and use the cable.</p>
Internal wiring	 <p>RDA ○ SA</p> <p>RDB ○ SB</p> <p>SG ○ SG</p>

(4) Ethernet

- Connection between PC and devices

For direct (one-to-one) connection, use crossover twist-pair cables with shield (available locally as STP cable).

- Connection between HUB and devices (multiple devices can be connected)

For (one-to-N) connection between PC and devices via HUB, use straight twist-pair cables with shield (available locally as STP cable).

3) Communications line wiring

(1) RS232C wiring

PC and devices are connected one-to-one with RS232C.

Example of terminal connection

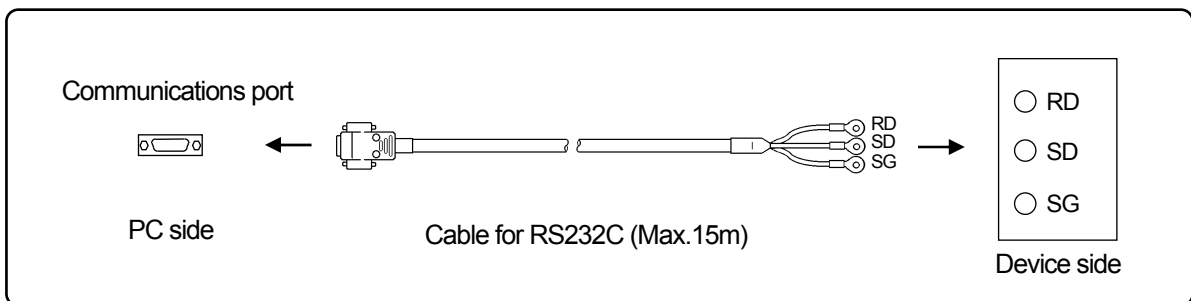

(2) RS422A wiring

PC and multiple devices are connected with RS422A. A line converter is required.
 RS422A cable is within 1.2km of total extension and up to 31 devices can be connected.
 Install a resistor of 100Ω to the last edge of the transmission line device side.
 (General metal film resistors will be fine. They are available from us, place an order.)

Example of terminal connection

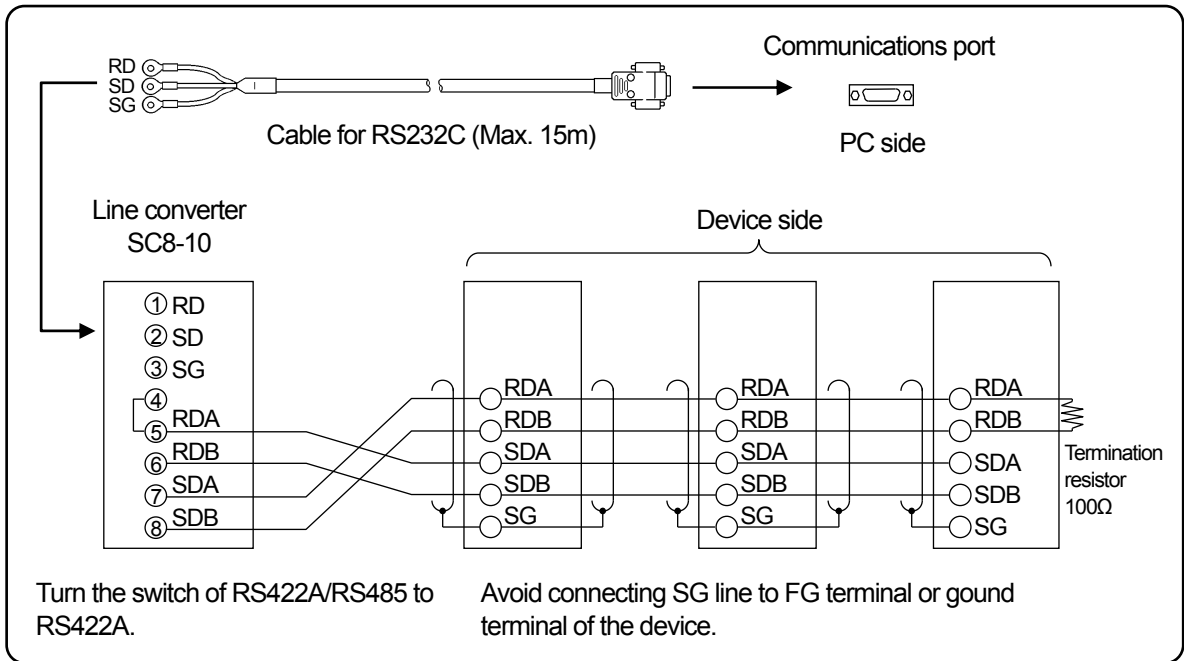

(3) RS485 wiring

PC and multiple devices are connected with RS485. A line converter is required.
 RS485 cable is within 1.2km of total extension and up to 31 devices can be connected.
 Install a resistor of 100Ω to the last edge of the transmission line device side.
 (General metal film resistors will be fine. They are available from us, place an order.)

Example of terminal connection

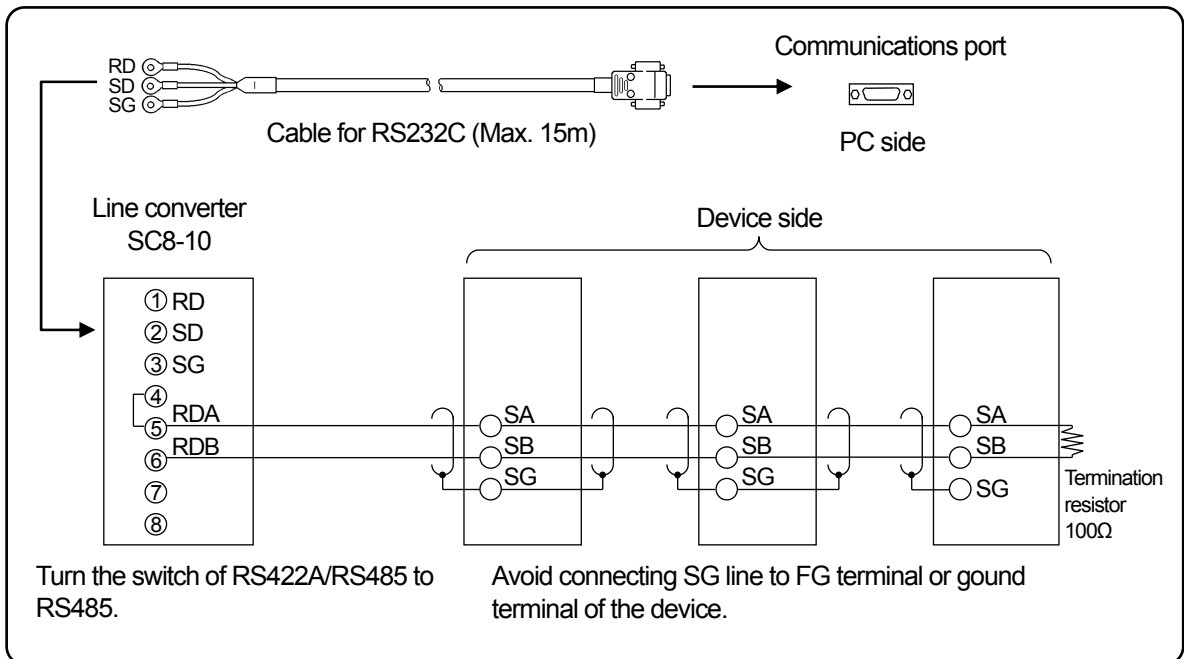

(4) Ethernet wiring

- Example of connection between PC and Ethernet devices (one-to-one connection)

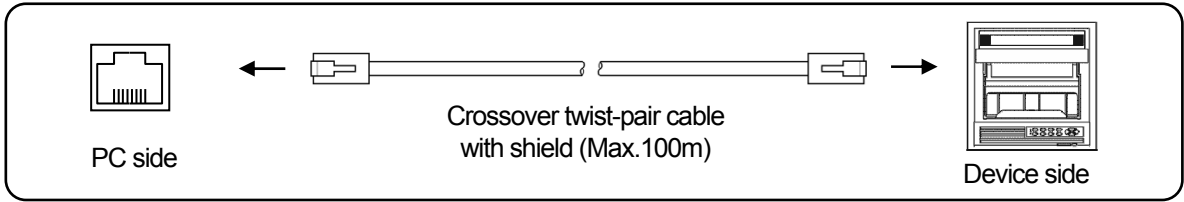

- Example of connection between PC and HUB/Ethernet devices (one-to-N connection)

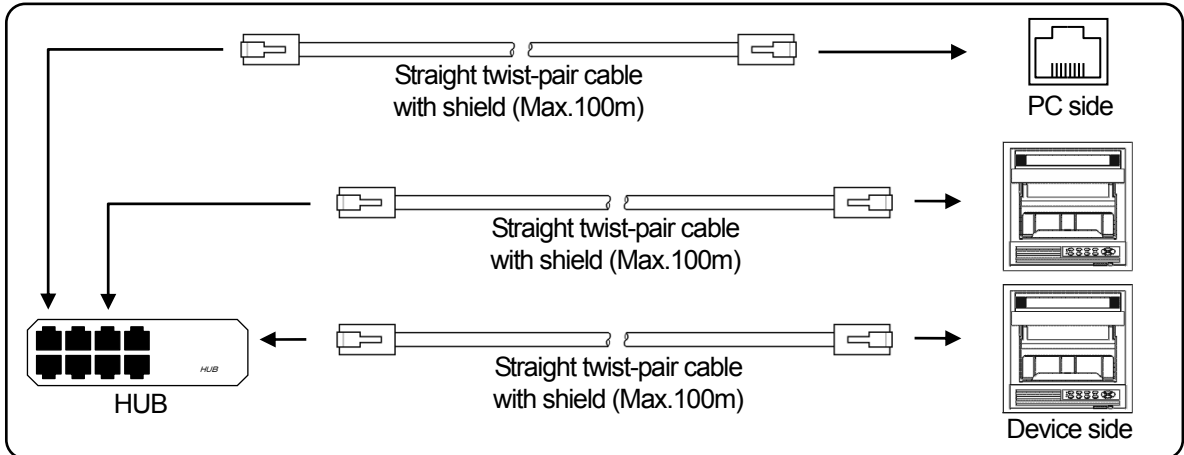

5. Part Names

5-1. Front Section of Internal Unit

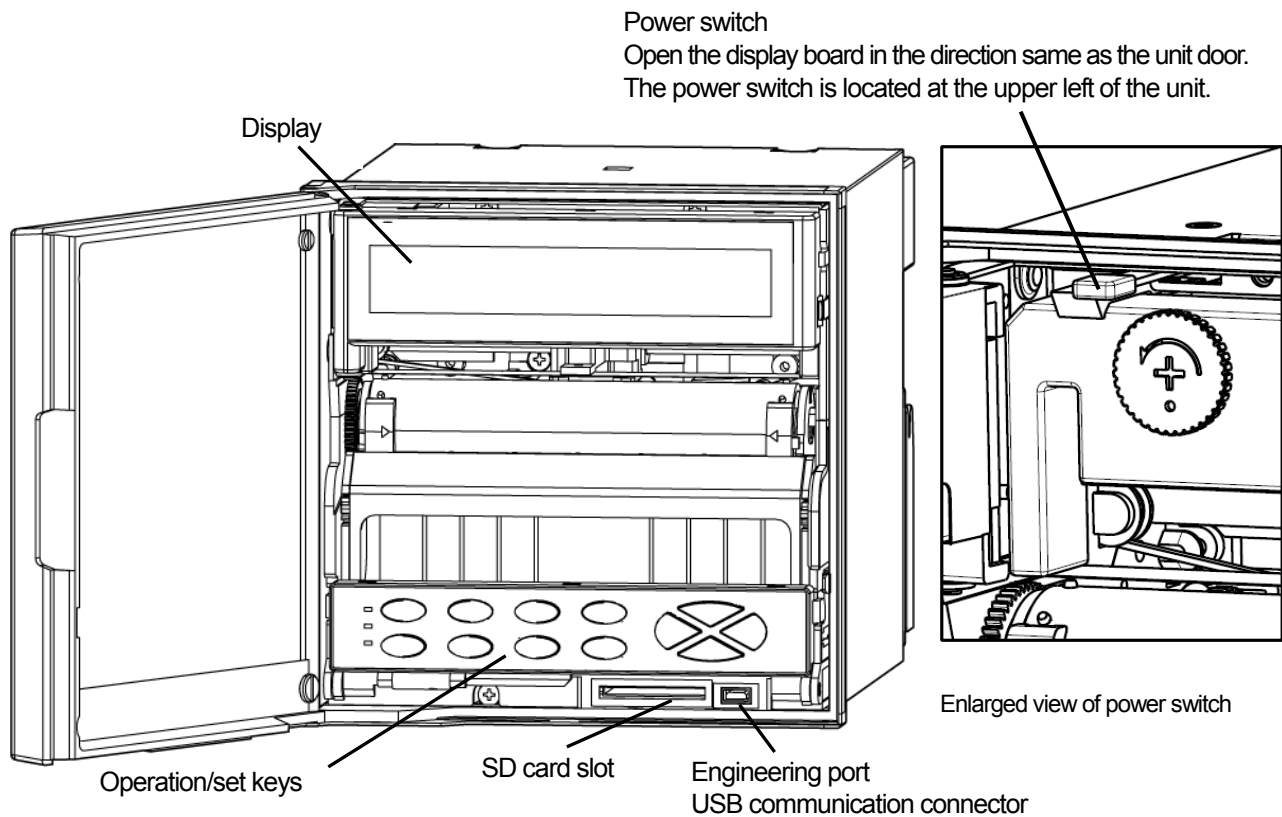

Note 1 How to handle the door

The front of the door is made of glass. Avoid giving any shock to the glass or giving any strong force to the frame for preventing any injury due to breakage.

Note 2 Operation/set key



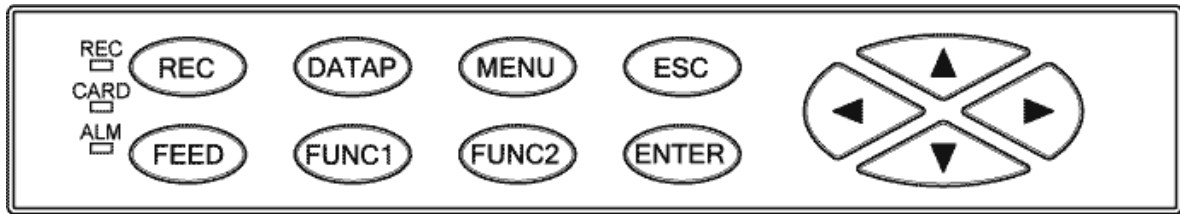

Avoid closing the door in the state of operation/set keys opened. If the door is closed in the state of the operation/set keys opened, the mechanism of the operation/set keys allows the operation/set keys to be lifted to the direction for closing to prevent damage; however, behavior for protection is not guaranteed. If the door is closed forcibly or fast, it may be damaged.

5-2. Operation/Set Keys



Status LED

- REC
Lights in green while recording is on. Recording is turned ON/OFF by the  key.
Flashes when chart ends.
- CARD
Lights in green when SD card is recognized by the unit, or flashes in a recognition process.
- ALM
Flashes in red when alarm occurs.

Key names		Functions
REC	Record key	Turns ON/OFF recording. Used with the  key.
FEED	Feed key	Feeds chart at a speed of 600mm/min while this key is pressed.
DATAP	Data print	Prints the data at the time of pressing this key. Used with the  key.
FUNC1	Function 1 key	Switches and sets functions (function is shown on the display).
FUNC2	Function 2 key	Switches and sets functions (function is shown on the display).
MENU	Menu key	Displays various setting items.
ESC	Escape key	Returns to the previously displayed screen.
 / 	Up/Down	Moves the cursor up/down and left/right.
	Left/Right	Used also to select setting items or values. Used also to advance the channel number.
ENTER	Enter key	Used to register various settings.

6. Operation

6-1. Preparation for Operation

1. How to set chart paper

1. Pulling out the chart cassette

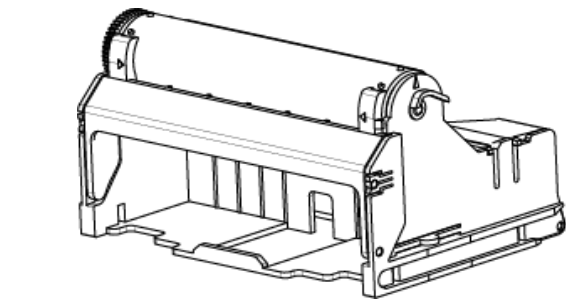
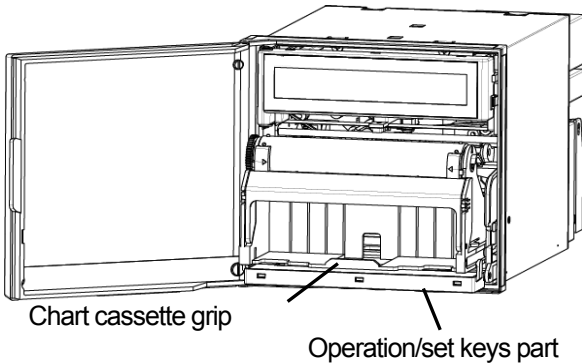

- (1) Open the unit door and pull the operation/set keys part.
- (2) Hold the chart cassette grip and pull it toward you.

2. Setting chart paper

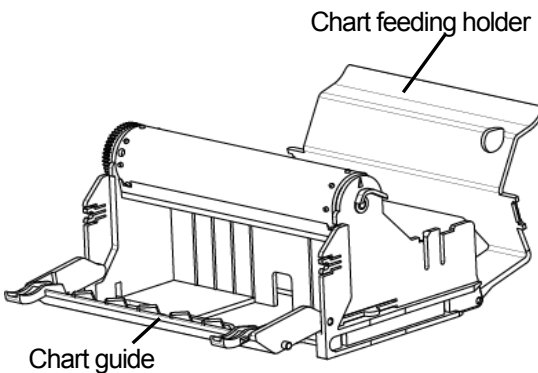

- (1) Open the chart guide and chart feeding holder.
- (2) Loosen the both ends of chart to prevent double feed.



Note Handling of chart cassette

Be careful of injury by dropping the chart cassette after pulling it from inner unit. Take care not to catch your fingers in the unit when putting the chart cassette back.

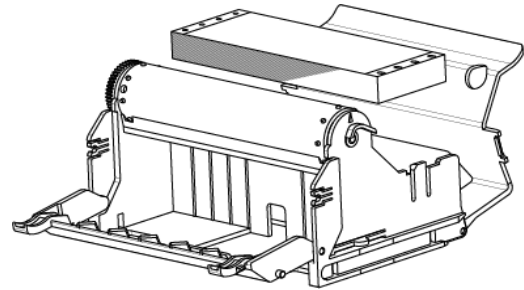

- (3) Set chart in the chart housing at the back of the chart cassette. The "square" hole and "rectangle" hole should be at the left and right side of the chart respectively.

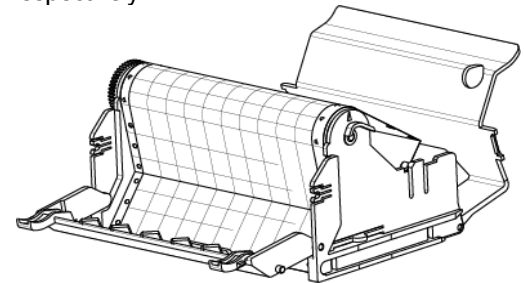

- (4) Draw out chart approximately 20cm and set holes on the both ends to the sprockets of the chart drum. Put two or three folds of chart in the chart tray at the front of the chart cassette and then close the chart guide and chart feeding holder opened in the step (1).

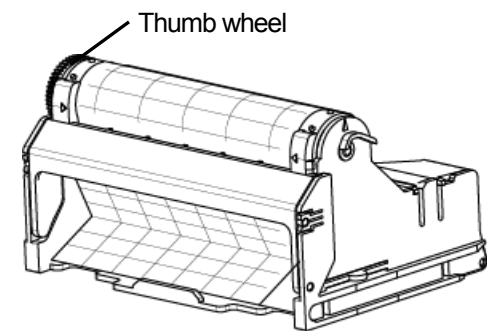

- (5) Turn the thumb wheel downward and make sure that the holes on the both ends of chart are not released from the sprockets, and feeding is smoothly done.

3. Returning the chart cassette to the inside of the unit

- (1) Align the guide of the chart cassette with the guide rail located at the both sides of the internal chassis and then insert the cassette until it is locked.
- (2) Put back the operation/set keys part.
- (3) Operate the **FEED** key to check if the chart is fed properly and smoothly. If not, reset the chart again.

2. How to attach ribbon cassette

1. Preparation

- (1) Make sure that the unit is turned ON and then press the **REC** key (recording OFF).
- (2) The printer stops around the center and the ribbon holder moves backward.
- (3) Prepare a ribbon cassette.

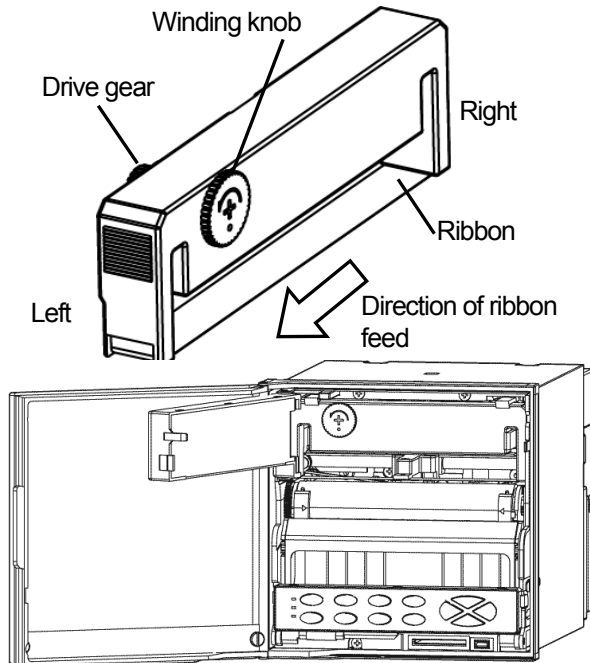

- (4) Open the unit door.
- (5) Open the display board in the direction same as the unit door.

2. Attaching ribbon cassette

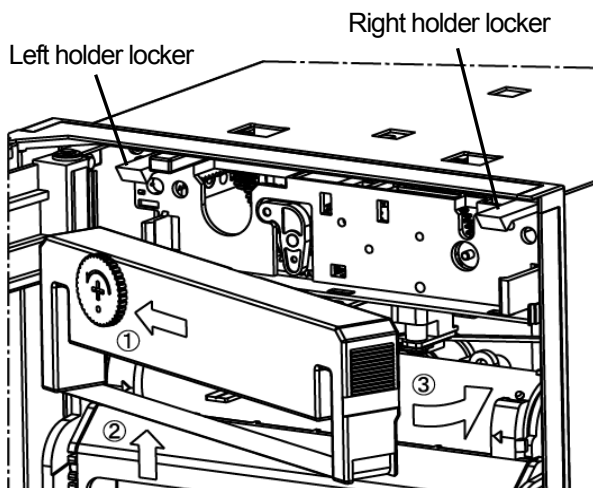

- (1) Insert a ribbon cassette to the left holder locker.
- (2) Put the ribbon under the printer and push the right side of the ribbon cassette.
- (3) Insert the ribbon cassette to the right holder locker.
- (4) Make sure that the ribbon cassette is properly held by the left and right holder lockers.
- (5) Turn the winding knob counterclockwise.
- (6) Return the display board in place.
- (7) Make sure that the unit is turned ON and then press the **REC** key (recording ON).

- (8) Feed the ribbon a few centimeters while recording is ON. Check the ribbon feeding condition.

3. Preparation for ribbon cassette replacement

- (1) Move the printer to the center and the ribbon holder backward as in the case of attaching a ribbon cassette.
- (2) Open the display board in the direction same as the unit door.

4. Removing ribbon cassette

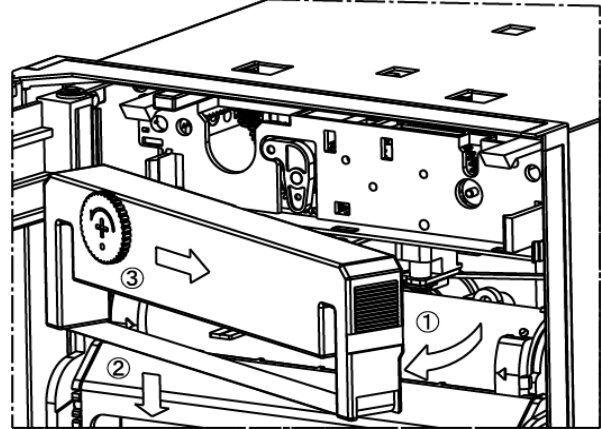

- (1) Pull the right side of the ribbon cassette to remove it from the right holder locker (see below tips for removal).



Put the tip of your index finger on the top of the ribbon cassette and roll it downward.

- (2) Pull the ribbon out of the printer.
- (3) Pull the left side of the ribbon cassette to remove it from the left holder locker.

Ref 1 When winding failure occurs

Draw out the ribbon from the left side and then wind up by turning the winding knob.

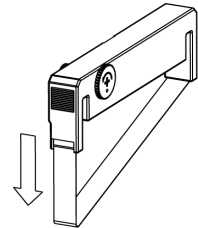

Ref 2 Replacement cycle of ribbon cassette

Under standard operating conditions (temperature: $23 \pm 2^\circ\text{C}$, humidity: $55 \pm 10\% \text{RH}$), it can last about three months. However, it may be shortened depending on temperature, humidity or use of the unit (chart speed, intervals of periodic data printing, etc.).

Note Replacement of ribbon cassette

When replacing the ribbon cassette, be careful not to catch your fingers in the unit.

6-2. Basic Operation

1. Power on

Turn the power switch to ON.

Data will be shown on the display after about 10 seconds.

After detecting the initial position, the printer prints the date and time and then feeds chart about 5mm.

Note 1 Display backup

Backup of settings, clock and display mode are made. However, channel number is not saved so the data with smallest channel number within set range will be displayed.

Note 2 While recording is OFF

The date/time printing is not performed at power-on.

2. Switching of display

The unit can provide three display modes.

Either fixed or sequential display can be selected for each display mode (pressing the **FUNC1** key switches the display between AUTO (sequential) and CONST (fixed).

With the sequential display, channel number advances every two seconds (factory default which can be changed).

While holding down the **ESC** key, press the   key to change the display mode.

See general "8-24. Display Settings" to set default display mode at power-on.

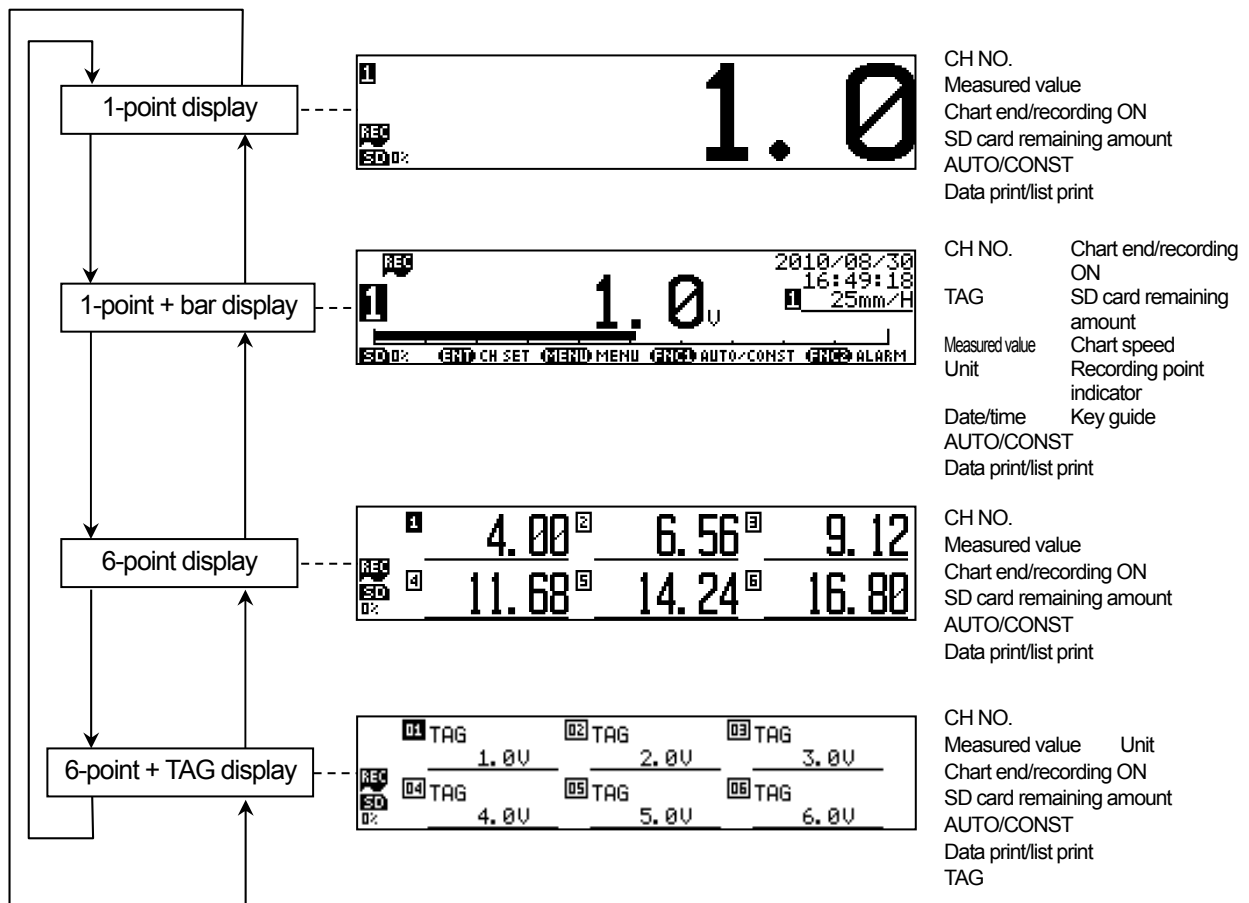

↓: ESC + ▲ ↑: ESC + ▼

To switch from "1-point display" to "1-point + bar display", press the  key while holding down the **ESC** key.

To switch from "1-point display" to "6 point display", press the  key while holding down the **ESC** key.

3) Chart feed

Chart can be fed using the **FEED** key.

While the **FEED** key is pressed, chart is fed at a speed of 600mm/min. When fast-feeding chart, recording (dot-printing) is stopped.

Feed chart when a measurement target or measurement condition is changed.

Reference Feeding chart

Due to the mechanical nature of the unit, a few millimeters of chart may not be fed. Therefore, we recommend that chart be fed by the **FEED** key.

Also, for the same reason, use the **FEED** key to feed when new chart is set.

4) Aligning time line

When operating the unit with a chart speed of multiples of 10 (mm/H), it is advisable to align the time line print with the time scale of chart for easier view of the result.

The following shows a bad example.

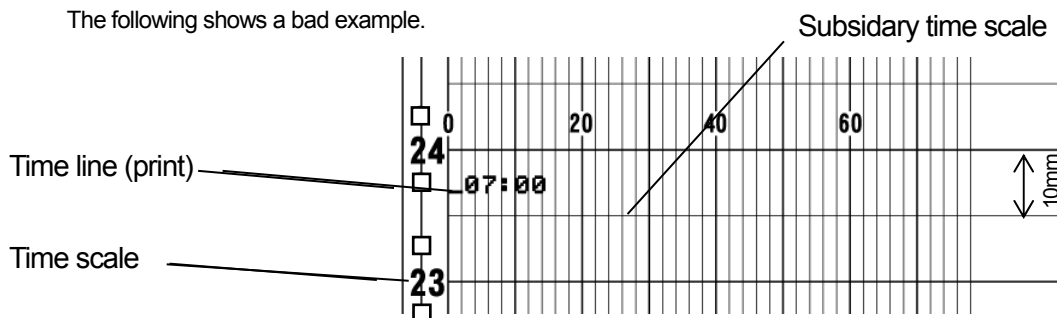

This is useful only when you use a chart with 10mm-pitch time scale.

(1) There is a time line setting mark (<) on the right side of the chart guide located at the front of the chart cassette.

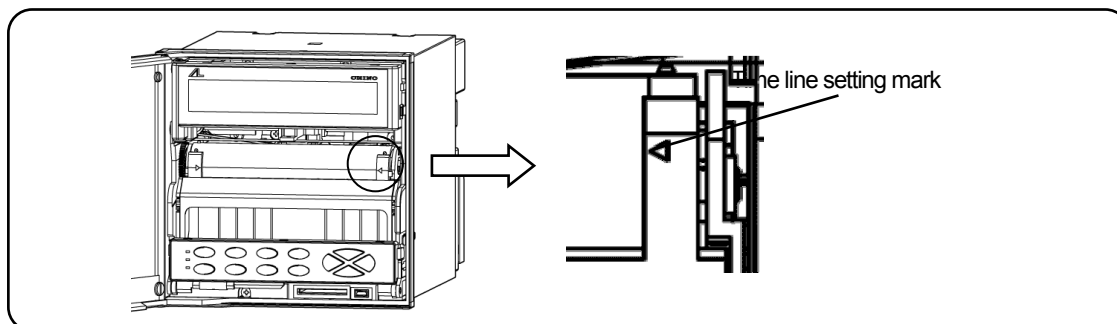

(2) Align a time scale line with the setting mark (<) as viewed from the front by pressing the **FEED** key (do not align it manually).

(3) It may be a good idea to set a time scale line 1 to 2mm above the setting mark (<) to perform a fine adjustment later.

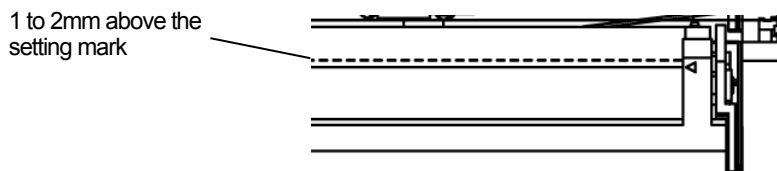

(4) Press the **REC** key and turn off the "REC" status LED.

(5) Press the **REC** key at a desired time <xxh 00min> and turn on the "REC" status LED.

(6) After a few hours, check to see if the time line print is aligned with a time scale line. If the time line print comes behind a time scale line, press the **FEED** key briefly and see how it works. If it comes ahead, remove the chart and set it back for a few hours and then try again.

7. Inspection and Maintenance

7-1. Routine Inspection

Check the remaining amount of chart and recording condition on a daily basis to keep the unit in good condition. When any abnormality is found, take an appropriate action according to the general "11. Troubleshooting".

Maintenance/inspection item	Operation
Ribbon cassette replacement	A ribbon cassette used for printing can last two to three months in continuous use, depending on the operating condition. When the print becomes less visible, replace the ribbon cassette with new one. (See "6-1.2. How to attach ribbon cassette".)
Chart replacement	A chart paper can last about 20 days when fed at a speed of 20mm/H continuously. When the end of chart nears, an end mark (red line on the right edge of chart) appears. In this case, replace the chart with new one. (See "6-1.1. How to set chart paper".)
Cleaning	Wipe away dirt on the unit with a soft, dry cloth or a cloth dampened with warm water or neutral detergent.



Caution

Do not use chemical solvents including thinner and benzene to prevent the unit surface from melting. The chart guide is made of acrylic. It may produce a crack when a chemical solvent is used.

7-2. Consumable Parts and Replacement Guideline

The unit includes some consumable parts. To use the unit for a long time in good condition, we recommend that these parts be replaced regularly.



Warning

Do not replace parts other than chart and ribbon cassette by yourself. Not only does it fail to replace properly, but it also may pose dangerous situation. Make sure to contact Azbil's sales agent for replacement of consumable parts.

1. Consumable parts and recommended replacement cycle

	Consumable part	Replacement cycle	Operating condition, etc.
Mechanical parts	Printer	4 to 6 years	Use under the normal condition as below: <ul style="list-style-type: none"> • Temp: 25°C, humidity: 80%RH or lower • No corrosive gas • Dust free, oil smoke free, dry place • Free from vibration and impact • No other factors affecting operation
	Printer main/sub axis and bearing	4 to 6 years	
	Belt	4 to 6 years	
	Chart drive mechanism	4 to 6 years	
	Ribbon select mechanism	4 to 6 years	
	Motors	4 to 6 years	
Electronic parts	Power supply	5 years	At an ambient temperature of 25°C
	Relay (for alarm)	100,000 times	Resistive load
		30,000 times	Inductive load
	Lithium battery	10 years	8-hour operation per day (at an ambient temperature of 40°C or lower)
	Keys	500,000 times	Depends highly on the use and surrounding conditions.
Display (LCD)	4 to 6 years	At an ambient temperature of 25°C	

7-3. The battery removal method for the purpose of disposal



Caution

Do not replace the battery. Doing so might cause damage or malfunction.
Do not remove the battery, except when disposing of the recorder.

1. Removing the battery

(When you discard this unit, please restrict and to it.)

- 1) Removing the internal chassis
 - (1) Open the unit door and then open the display board in the same direction.
 - (2) Turn OFF the power switch.
 - (3) Remove three screws fixing the internal chassis and pull out the internal unit.

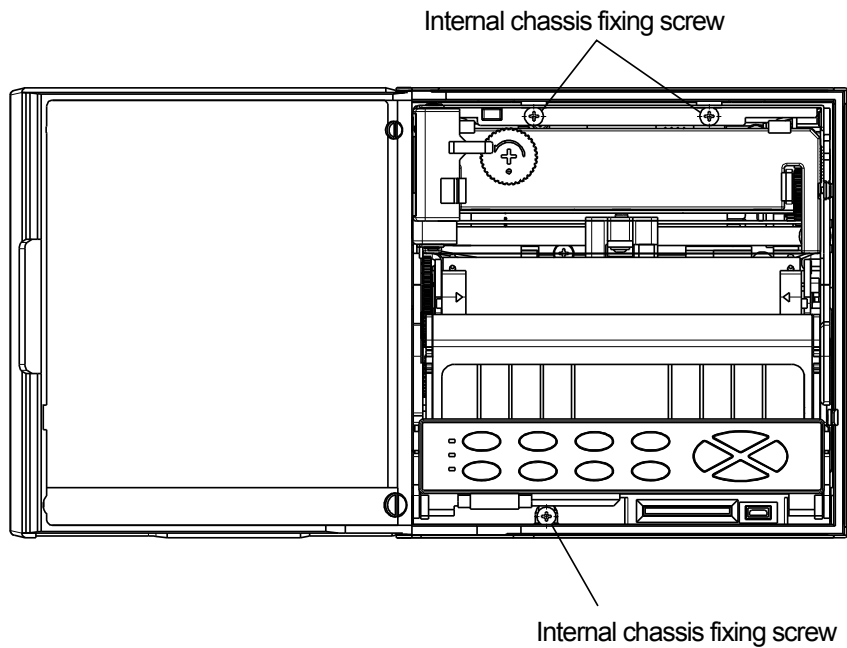

- 2) Removing the battery
 - (1) The battery is located at the back of the internal unit.

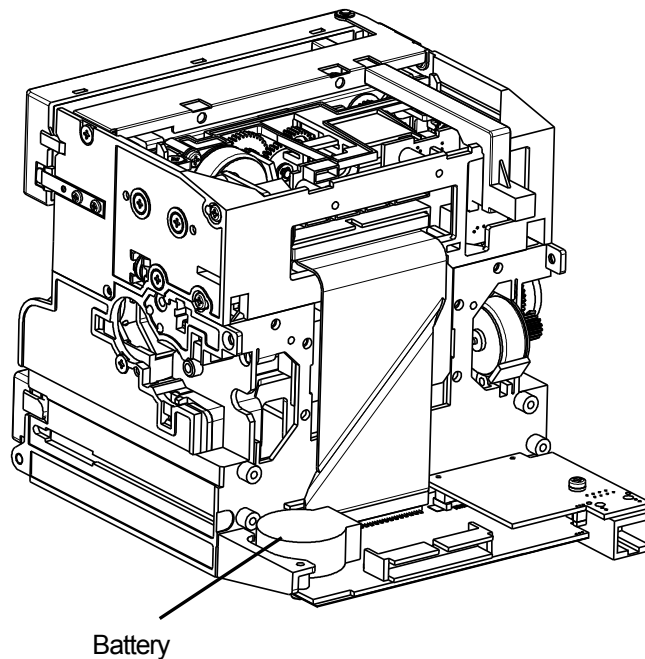

(2) Using a tapered, insulated tool, remove the battery from the battery holder.

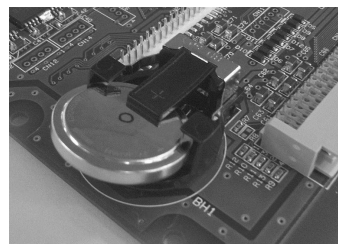
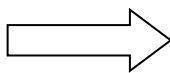
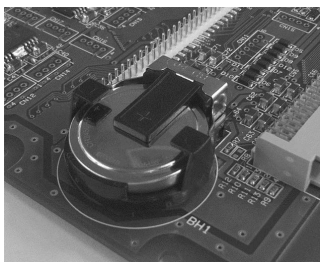

 Caution	<ol style="list-style-type: none">(1) The unit components include a small amount of harmful chemical substance no more than the defined amount by RoHS.(2) The unit must be disposed of by a waste disposal company or in accordance with the local regulations.(3) The unit uses a lithium battery and the battery must be disposed of by a waste disposal company.(4) The packing materials used for the unit, such as box, plastic bag, cushion and sticker, should be sorted for recycling in accordance with local regulations.
--	---

Revision History of CP-UM-5744E

Printed	Edn.	Revised pages	Description
Nov. 2013	1		
Sep. 2014	2	End	Change AAS-511A-014-03 to AAS-511A-014-04
Apr. 2016	3	2 6 17 20 30 End	Change the number of figures of serial number 3. Add SD playback 2), (2) Change 13 pages → 4-3. Wiring, 2. Precautions on wiring 4), (8) Change the sentences 6-2. 2. Add "6-point + TAG display" Change AAS-511A-014-04 to AAS-511A-014-06
June 2017	4	End	Add "Revision History of CP-UM-5744E"

MEMO

Terms and Conditions

We would like to express our appreciation for your purchase and use of Azbil Corporation's products. You are required to acknowledge and agree upon the following terms and conditions for your purchase of Azbil Corporation's products (system products, field instruments, control valves, and control products), unless otherwise stated in any separate document, including, without limitation, estimation sheets, written agreements, catalogs, specifications and instruction manuals.

1. Warranty period and warranty scope

1.1 Warranty period

Azbil Corporation's products shall be warranted for one (1) year from the date of your purchase of the said products or the delivery of the said products to a place designated by you.

1.2 Warranty scope

In the event that Azbil Corporation's product has any failure attributable to azbil during the aforementioned warranty period, Azbil Corporation shall, without charge, deliver a replacement for the said product to the place where you purchased, or repair the said product and deliver it to the aforementioned place.

Notwithstanding the foregoing, any failure falling under one of the following shall not be covered under this warranty:

- (1) Failure caused by your improper use of azbil product (noncompliance with conditions, environment of use, precautions, etc. set forth in catalogs, specifications, instruction manuals, etc.);
- (2) Failure caused for other reasons than Azbil Corporation's product;
- (3) Failure caused by any modification or repair made by any person other than Azbil Corporation or Azbil Corporation's subcontractors;
- (4) Failure caused by your use of Azbil Corporation's product in a manner not conforming to the intended usage of that product;
- (5) Failure that the state-of-the-art at the time of Azbil Corporation's shipment did not allow Azbil Corporation to predict; or
- (6) Failure that arose from any reason not attributable to Azbil Corporation, including, without limitation, acts of God, disasters, and actions taken by a third party.

Please note that the term "warranty" as used herein refers to equipment-only-warranty, and Azbil Corporation shall not be liable for any damages, including direct, indirect, special, incidental or consequential damages in connection with or arising out of Azbil Corporation's products.

2. Ascertainment of suitability

You are required to ascertain the suitability of Azbil Corporation's product in case of your use of the same with your machinery, equipment, etc. (hereinafter referred to as "Equipment") on your own responsibility, taking the following matters into consideration:

- (1) Regulations and standards or laws that your Equipment is to comply with.
- (2) Examples of application described in any documents provided by Azbil Corporation are for your reference purpose only, and you are required to check the functions and safety of your Equipment prior to your use.
- (3) Measures to be taken to secure the required level of the reliability and safety of your Equipment in your use
Although azbil is constantly making efforts to improve the quality and reliability of Azbil Corporation's products, there exists a possibility that parts and machinery may break down.
You are required to provide your Equipment with safety design such as fool-proof design, *1 and fail-safe design*2 (anti-flame propagation design, etc.), whereby preventing any occurrence of physical injuries, fires, significant damage, and so forth. Furthermore, fault avoidance,*3 fault tolerance,*4 or the like should be incorporated so that the said Equipment can satisfy the level of reliability and safety required for your use.

*1. A design that is safe even if the user makes an error.

*2. A design that is safe even if the device fails.

*3. Avoidance of device failure by using highly reliable components, etc.

*4. The use of redundancy.

3. Precautions and restrictions on application

Azbil Corporation's products other than those explicitly specified as applicable (e.g. azbil Limit Switch For Nuclear Energy) shall not be used in a nuclear energy controlled area (radiation controlled area).

Any Azbil Corporation's products shall not be used for/with medical equipment.

The products are for industrial use. Do not allow general consumers to install or use any Azbil Corporation's product.

However, azbil products can be incorporated into products used by general consumers. If you intend to use a product for that purpose, please contact one of our sales representatives.

In addition,

you are required to conduct a consultation with our sales representative and understand detail specifications, cautions for operation, and so forth by reference to catalogs, specifications, instruction manual, etc. in case that you intend to use azbil product for any purposes specified in (1) through (6) below.

Moreover, you are required to provide your Equipment with fool-proof design, fail-safe design, anti-flame propagation design, fault avoidance, fault tolerance, and other kinds of protection/safety circuit design on your own responsibility to ensure reliability and safety, whereby preventing problems caused by failure or nonconformity.

- (1) For use under such conditions or in such environments as not stated in technical documents, including catalogs, specification, and instruction manuals
- (2) For use of specific purposes, such as:
 - * Nuclear energy/radiation related facilities
[For use outside nuclear energy controlled areas] [For use of Azbil Corporation's Limit Switch For Nuclear Energy]
 - * Machinery or equipment for space/sea bottom
 - * Transportation equipment
[Railway, aircraft, vessels, vehicle equipment, etc.]
 - * Antidisaster/crime-prevention equipment

- * Burning appliances
 - * Electrothermal equipment
 - * Amusement facilities
 - * Facilities/applications associated directly with billing
- (3) Supply systems such as electricity/gas/water supply systems, large-scale communication systems, and traffic/air traffic control systems requiring high reliability
 - (4) Facilities that are to comply with regulations of governmental/public agencies or specific industries
 - (5) Machinery or equipment that may affect human lives, human bodies or properties
 - (6) Other machinery or equipment equivalent to those set forth in items (1) to (5) above which require high reliability and safety
4. Precautions against long-term use

Use of Azbil Corporation's products, including switches, which contain electronic components, over a prolonged period may degrade insulation or increase contact-resistance and may result in heat generation or any other similar problem causing such product or switch to develop safety hazards such as smoking, ignition, and electrification. Although acceleration of the above situation varies depending on the conditions or environment of use of the products, you are required not to use any Azbil Corporation's products for a period exceeding ten (10) years unless otherwise stated in specifications or instruction manuals.
 5. Recommendation for renewal

Mechanical components, such as relays and switches, used for Azbil Corporation's products will reach the end of their life due to wear by repetitious open/close operations. In addition, electronic components such as electrolytic capacitors will reach the end of their life due to aged deterioration based on the conditions or environment in which such electronic components are used. Although acceleration of the above situation varies depending on the conditions or environment of use, the number of open/close operations of relays, etc. as prescribed in specifications or instruction manuals, or depending on the design margin of your machine or equipment, you are required to renew any Azbil Corporation's products every 5 to 10 years unless otherwise specified in specifications or instruction manuals. System products, field instruments (sensors such as pressure/flow/level sensors, regulating valves, etc.) will reach the end of their life due to aged deterioration of parts. For those parts that will reach the end of their life due to aged deterioration, recommended replacement cycles are prescribed. You are required to replace parts based on such recommended replacement cycles.
 6. Other precautions

Prior to your use of Azbil Corporation's products, you are required to understand and comply with specifications (e.g., conditions and environment of use), precautions, warnings/cautions/notices as set forth in the technical documents prepared for individual Azbil Corporation's products, such as catalogs, specifications, and instruction manuals to ensure the quality, reliability, and safety of those products.
 7. Changes to specifications

Please note that the descriptions contained in any documents provided by azbil are subject to change without notice for improvement or for any other reason. For inquires or information on specifications as you may need to check, please contact our branch offices or sales offices, or your local sales agents.
 8. Discontinuance of the supply of products/parts

Please note that the production of any Azbil Corporation's product may be discontinued without notice. For repairable products, we will, in principle, undertake repairs for five (5) years after the discontinuance of those products. In some cases, however, we cannot undertake such repairs for reasons, such as the absence of repair parts. For system products, field instruments, we may not be able to undertake parts replacement for similar reasons.
 9. Scope of services

Prices of Azbil Corporation's products do not include any charges for services such as engineer dispatch service. Accordingly, a separate fee will be charged in any of the following cases:

 - (1) Installation, adjustment, guidance, and attendance at a test run
 - (2) Maintenance, inspection, adjustment, and repair
 - (3) Technical guidance and technical education
 - (4) Special test or special inspection of a product under the conditions specified by you

Please note that we cannot provide any services as set forth above in a nuclear energy controlled area (radiation controlled area) or at a place where the level of exposure to radiation is equivalent to that in a nuclear energy controlled area.



Specifications are subject to change without notice. (09)

[Selling agency]

Azbil Corporation
Advanced Automation Company

1-12-2 Kawana, Fujisawa
Kanagawa 251-8522 Japan

URL: <http://www.azbil.com>

[Manufacturer]

CHINO Corporation

32-8 KUMANO-CHO, ITABASHI-KU,
TOKYO 173-8632 JAPAN

1st edition: Nov. 2013 (K)

4th edition: June 2017 (K)