

azbil

**Electromagnetic Flowmeter
for Water Measurement
Model: MCB10A**

User's Manual



Azbil Corporation

CM2-MCB100-2001
2nd edition

Copyright, Notices and Trademarks

© 2004-2012 Azbil Corporation All Rights Reserved.

While this information is presented in good faith and believed to be accurate, Azbil Corporation disclaims the implied warranties of merchantability and fitness for a particular purpose and makes no express warranties except as may be stated in its written agreement with and for its customer.

In no event is Azbil Corporation liable to anyone for any indirect, special or consequential damages. This information and specifications in this document are subject to change without notice.

Preface

Thank you for purchasing our electromagnetic flowmeter. The model MCB is a flowmeter dedicated to water flow measurement and was developed applying the basic principle of electromagnetic flow measurement to be an inexpensive, easy-to-use instrument.

Unpacking, product checking and storage

Unpacking

This instrument is a precision instrument. When unpacking, handle it with care to prevent accidents or damage. Check that the following items are contained:

- MCB main unit, standard accessories and SETTING DATA sheet

Verifying the specifications

Specifications are written on the nameplate of the main unit. Referring to Specification sheet, check that these are consistent with your specifications. Check the following items, in particular:

(Main unit)

- Detector bore diameter
- Flange rating

Inquiries

If you have any questions regarding the specifications, contact the nearest Azbil Corporation office or Azbil Corporation representative service offices. When making an inquiry, be sure to provide the MODEL NO. and PRODUCT NO.

Storage precautions

When storing this instrument before use, observe the following precautions:

- Store it indoors and at room temperature (25°C, 77°F) and humidity (65% RH), safely away from vibration or shock.
- Store it in its packed and shipped state.

When storing this instrument after use, follow these steps:

1. Rinse the inside of the detector with water to remove the adhering measured fluid and dry off the water.
2. Tighten the display cover and waterproof gland to keep out moisture.
3. Replace the device in its original packing.
4. Store it indoors at room temperature and humidity, safely away from vibration and shock.

Safety

About this manual

This manual contains information and warnings that must be observed to keep the model MCB10A electromagnetic flowmeter operating safely. Correct installation, correct operation and regular maintenance are essential to ensure safety while using this device.

For the correct and safe use of this electromagnetic flowmeter, it is essential that both operating and service personnel follow generally accepted safety procedures in addition to the safety precautions specified in this manual.

The following symbols are used in this manual to alert you to possible hazards:

WARNING

Denotes a potentially hazardous situation which, if not avoided, could result in death or serious injury.

CAUTION

Failure to observe these precautions may produce dangerous conditions that could result in operator injury or in physical damage to the device.

Safety message

Carefully read this section before installing or operating this device.

WARNING

ELECTRIC SHOCK HAZARD! Turn the power supply OFF before opening the converter cover.

WARNING

This detector is heavy. Dropping it could cause personal injury or damage to the device.

WARNING

Before removing the unit, make sure that there is no residual liquid or pressure inside the piping and the detector to avoid personal injury or damage to the unit.

⚠ CAUTION

Switch the control equipment to manual control before terminating electromagnetic flowmeter operation and shutting off the output to the control equipment. This action prevents the power shut-off from directly affecting the control equipment.

⚠ CAUTION

Install the electromagnetic flowmeter in a location with an ambient temperature of 0 to 50°C (32 to 122°F) and an ambient humidity of 5 to 85% RH (no condensation) to prevent equipment malfunction or output errors.

⚠ CAUTION

Do not install the electromagnetic flowmeter near high-current power lines, motors or transformers to prevent damage from electromagnetic induction, which can cause equipment malfunction or output errors.

⚠ CAUTION

Do not install the electromagnetic flowmeter in a location subject to direct sunlight, wind, rain, severe vibration, or in a highly corrosive atmosphere. The converter and detector can be damaged. The electromagnetic flowmeter is for indoor use only.

⚠ CAUTION

Be sure to ground the welding power transformer when welding near the electromagnetic flowmeter to avoid output errors.

⚠ CAUTION

DO NOT use the electromagnetic flowmeter to ground a welder. It can damage the electromagnetic flowmeter.

⚠ CAUTION

The detector must be grounded (grounding resistance is $< 100 \Omega$) to avoid output fluctuation, zero point instability or output drift.

⚠ CAUTION

Measurable process fluids of the electromagnetic flowmeter are chilled water, water with glycol, water and hot water. No corrosive fluid and no abrasive fluid is applicable. Corrosive fluid and abrasive fluid can damage the electromagnetic flowmeter.

⚠ CAUTION

If the pipe is not filled, output errors will occur.

⚠ CAUTION

Do not rotate the unit more than 180° (one half rotation). Any further rotation can disconnect wiring.
After removing the screws, do not pull on the converter. You can break the lead wire.
When you move the converter, make sure the O-ring remains in the groove to insure an air-tight seal when the unit is reassembled.

⚠ CAUTION

Before installing the detector, make sure any foreign matter is flushed from the interior passage of the detector. Residual foreign matter could cause output fluctuations.
Do not touch the electrodes or allow oil or fat to come into contact with them to avoid output fluctuations.
Align the direction mark on the detector in the direction of the liquid flow.
Misalignment can result in a negative output.

⚠ CAUTION

The correct fastening torque must be used to prevent leakage. To avoid damage to the detector, do not exceed the listed fastening torque.

⚠ CAUTION

Before installing the detector, make sure that the pipe is exactly straight and centered. Any irregularity could cause leakage or other hazards.

 CAUTION

Never attempt to force the detector between two flange if the space is too narrow. It can damage the detector.

 CAUTION

Make certain the bore diameters of the pipe and the detector are exactly the same and install the detector so that the gasket does not protrude into the inner bore of the pipe, as this could result in leakage or other hazards.

 CAUTION

Tighten each bolt a little at a time and apply uniform pressure to all the bolts. If leakage continues after tightening the bolts, make sure that the pipe is not off center, then continue to tighten each bolt a little at a time.

 CAUTION

Using a gasket with too small a diameter can affect the flow velocity distribution, resulting in inaccurate measurement.
Using a gasket with too large a diameter can cause leakage. Also, any solid substance in the fluid to be measured could accumulate between the gasket and the flange, resulting in inaccurate measurement.

 CAUTION

The use of rubber gaskets and a lower fastening torque is not recommended and can cause insufficient surface pressure between the lining and the grounding ring, resulting in leakage.

 CAUTION

Insufficient grounding can cause output fluctuations, instability of the zero point, or output drift. Secure single point grounding with a grounding resistance of 100 Ω or less is recommended.
Do not ground a welder to the detector to avoid damaging the detector.

Table of Contents

Chapter 1: Configuration and structure of measuring system

Outline of this chapter.....	1-1
1-1: Loop configuration	1-2
1-1-1: Measuring system.....	1-2
1-1-2: Loop configuration for analog output	1-3
1-1-3: Loop configuration for pulse output	1-4
1-1-4: Loop configuration for contact output	1-5
1-2: Structure of this instrument and functions of its various parts.....	1-6
1-2-1: Structure of main unit.....	1-6
1-2-2: Detector: Wafer type.....	1-7
1-2-3: Indicator/data setter	1-8
1-2-4: Terminal block	1-9

Chapter 2: Instrument installation

Outline of this chapter.....	2-1
2-1: Before installation	2-2
2-1-1: Criteria (1) for selecting an installation location	2-2
2-1-2: Criteria (2) for selecting an installation location	2-4
2-1-3: Direction of indicator/data setter	2-6
2-1-4: Direction of the converter.....	2-7
2-2: Installation method.....	2-8
2-2-1: Installation of wafer-type detector.....	2-8
Basic installing method.....	2-8
Components necessary for installation.....	2-11
Selecting an installing method.....	2-13
Installing method on a horizontal pipe	2-14
Installing method on a vertical pipe	2-15
Installing method (1) on a metallic pipe	2-17
Installing method (1) on a polyvinyl chloride pipe.....	2-18

Chapter 3: Electrical wiring

Outline of this chapter.....	3-1
3-1: Electrical wiring	3-2
3-1-1: Electrical wiring.....	3-2

Chapter 4: Operation

Outline of this chapter.....	4-1
4-1: Confirmation before start-up	4-2
4-2: Stopping	4-2

Table of Contents

Chapter 5: Operation using the data setting device

5-1: Startup	5-2
5-1-1: Display and operation contents of data setting device	5-3
5-2: Functions of the data setting device	5-5
5-2-1: Data setting device	5-5
5-3: Description of MEASURING MODE	5-7
5-3-1: Display overview	5-7
5-4: Overview of operation using the data setting device	5-9
5-5: Configuration of OPERATOR'S MODE	5-10
5-5-1: Changing setting of damping time constant	5-12
5-5-2: Auto zero adjustment	5-13
5-5-3: Setting built-in counter reset value	5-14
5-5-4: Resetting built-in counter totalized value	5-15
5-5-5: Setting auto spike cut	5-16
5-5-6: Setting moving average processing	5-17
5-5-7: Selecting flow rate to be displayed in the main display	5-19
5-5-8: Entering ENGINEERING MODE and MAINTENANCE MODE	5-20
5-6: Configuration of ENGINEERING MODE	5-22
5-6-1: Setting ID	5-25
5-6-2: Selecting pulse output or contact output	5-26
5-6-3: Setting detector information	5-27
5-6-4: Setting flow rate range	5-28
5-6-5: Setting and changing compensation coefficient	5-29
5-6-6: Setting specific gravity	5-30
5-6-7: Setting pulse scale	5-31
5-6-8: Setting pulse width	5-33
5-6-9: Setting drop out	5-36
5-6-10: Setting low flow cutoff	5-37
5-6-11: Setting upper and lower limit alarm	5-38
5-6-12: Selecting failsafe mode for analog outputs	5-39
5-6-13: Selecting failsafe mode for pulse output	5-40
5-6-14: Setting contact output status	5-41
5-6-15: Selecting failsafe mode for pulse output	5-42
5-7: Configuration of MAINTENANCE MODE	5-43
5-7-1: Configuration of OUTPUT CHECK MODE	5-44
5-7-2: Performing loop checks of analog outputs	5-45
5-7-3: Performing loop checks of pulse outputs	5-46
5-7-4: Performing loop checks of contact outputs	5-47
5-7-5: Configuration of CALIBRATION MODE	5-48
5-7-6: Configuration of CRITICAL MODE	5-50
5-7-7: Displaying ROM version and date	5-51
5-7-8: Returning to settings at shipment	5-52
5-8: Description of error messages	5-53
5-8-1: Critical failure	5-53

Table of Contents

5-8-2: Non-critical error	5-54
5-8-3: Status indication	5-55

Chapter 6: Maintenance and troubleshooting

Outline of this chapter.....	6-1
6-1: Maintenance and inspection of hardware	6-2
6-1-1: Replacement of indicator/data setter	6-2
6-2: Troubleshooting	6-3
6-2-1: Types of troubles	6-3
6-2-2: Troubles at startup.....	6-4
6-2-3: Trouble during operation.....	6-5

List of Figures & Tables

<Figures & Photographs>

Figure 1-1: Conceptual drawing of measuring system (integral type)	1-2
Figure 1-2: Loop configuration for analog output	1-3
Figure 1-3: Loop configuration for pulse output	1-4
Figure 1-4: Loop configuration for contact output	1-5
Figure 1-5: General view of integral type	1-6
Figure 1-6: Detector details (wafer-type)	1-7
Photograph 1-1: Indicator/data setter details	1-8
Photograph 1-2: Indicator/data setter details	1-9
Figure 2-1: Example of installation	2-4
Figure 2-2: Straight pipe section upstream of detector	2-4
Figure 2-3: Necessary space for inspection	2-5
Figure 2-4: Changing the indicator/data setter direction	2-6
Figure 2-6: Example of installation	2-8
Figure 2-7: Flange shape	2-9
Figure 2-8: Example (1) of incorrect installation	2-10
Figure 2-9: Example (2) of incorrect installation	2-10
Figure 2-10: Horizontal mounting	2-11
Figure 2-11: Vertical mounting	2-11
Figure 2-12: Grounding ring of SUS material	2-17
Figure 2-13: Grounding ring made of SUS material	2-18
Figure 2-14: Grounding ring made of SUS material (protective fixture used)	2-19
Figure 2-15: Grounding ring made of SUS material (rubber gasket used)	2-19
Figure 3-1: Grounding	3-3
Figure 3-2: Pulse output wire connection diagram	3-4
Figure 3-3: Contact output wire connection diagram	3-4
Figure 5-1: Damping output characteristics	5-12
Figure 5-2: Auto spike cut output characteristics	5-16
Figure 5-3: Output characteristics of moving average processing	5-17
Figure 6-1: Replacement of indicator/data setter (with the cover removed)	6-2

<Tables>

Table 2-1: Tightening torque	2-9
Table 2-2: Recommended gasket internal diameter of full-face gaskets	2-12
Table 2-3: Internal and external diameter of rubber gaskets 0.5 to 1 mm thick	2-12
Table 2-4: Internal and external diameter of rubber gaskets 3 to 4 mm thick	2-12

Chapter 1 : Configuration and structure of measuring system

Outline of this chapter

This chapter presents the equipment configuration of a measuring system using this instrument.

- It also describes the structure, the names and functions of various parts of the main unit.

1-1 : Loop configuration

1-1-1 : Measuring system

Introduction

This instrument is an electromagnetic flowmeter and outputs analog and pulse or contact output. It measures the flow rate of a conductive fluid flowing in the sensor and outputs a signal according to the set range.

Concept of flow rate measurement by this instrument

The concept of a flow rate measuring system using this instrument is shown.

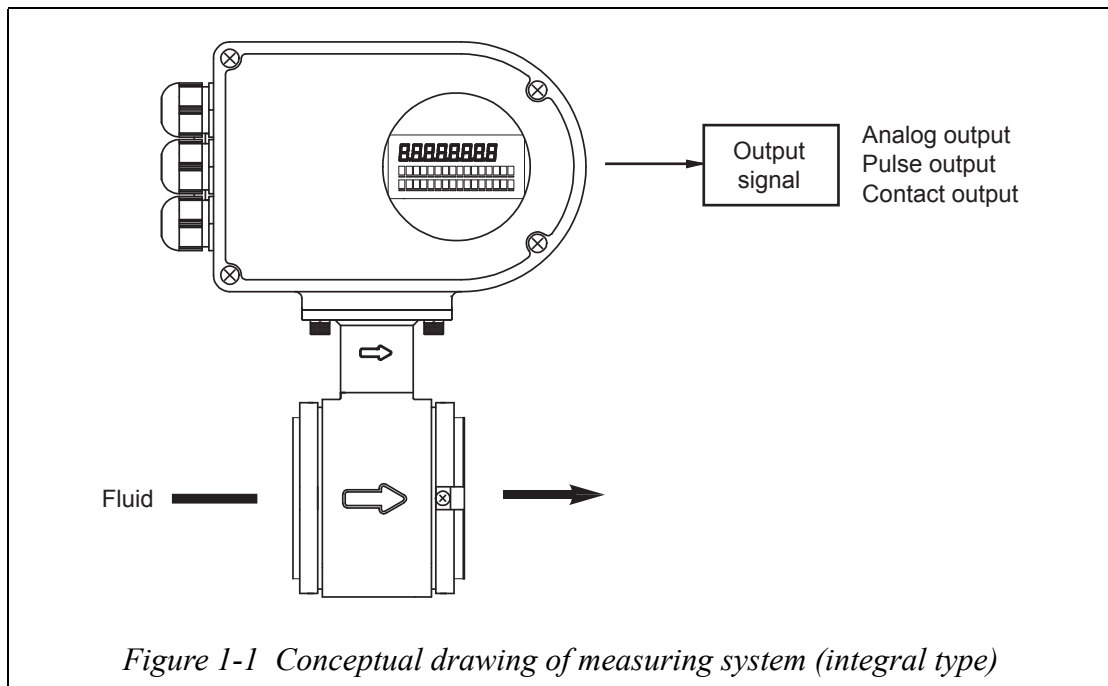

Analog output

If instantaneous flow rate values are to be output as an analog variable to control equipment, configure the system to deliver an analog output.

Pulse output

As a pulse output, the open-collector output is available. Pulse frequencies up to 200 Hz can be delivered. The pulse output can be delivered simultaneously with an analog output.

Contact output

Instead of the pulse output, a contact output is available using the open-collector output. The contact output can be delivered simultaneously with an analog output.

1-1-2 : Loop configuration for analog output

An example of system configuration is shown. The instantaneous flow rate values measured by this instrument are delivered as a 4-20 mA DC analog signal.

In this loop configuration, the analog signal from the instrument can be delivered directly to a host control system.

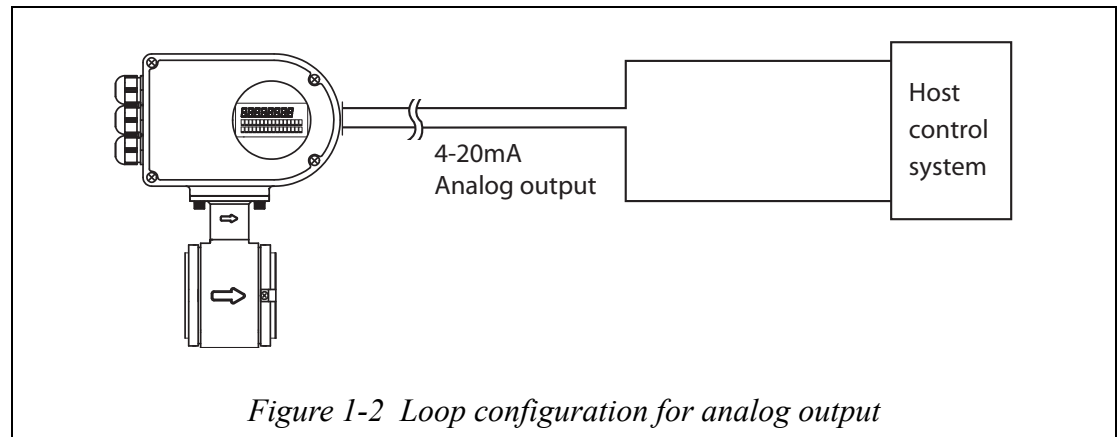

- Electromagnetic flowmeter (main unit): Measures flow rate and outputs instantaneous flow rate value as an analog signal.

When configuring a system using this instrument, it is necessary to determine the supply power voltage and load resistance to satisfy the operation conditions of this instrument.

For details, refer to Specification Sheet.

1-1-3 : Loop configuration for pulse output

An example of loop configuration is shown. Instantaneous flow rate values measured by this instrument are delivered as a pulse output with the specified pulse width and pulse weight.

In addition to an analog signal, this loop configuration allows the instrument to deliver a pulse output to an electronic counter, sequencer or other host control system or counter.

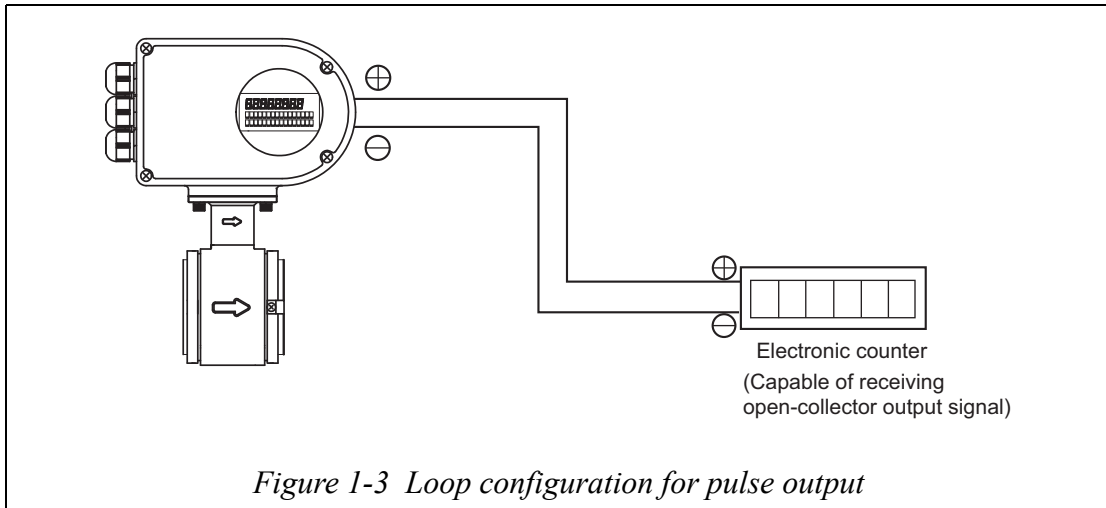

- Electromagnetic flowmeter (main unit): Measures flow rate and outputs a pulse output signal to an electronic counter. Displays the measured flow rate as a flow rate value.
- Electronic counter: Receives the pulse output as input and displays the totalized value. Batch or other types of control take place based on the totalized value on the electronic counter.
- Open collector: A pulse output method using a transistor contact.

1-1-4 : Loop configuration for contact output

An example of loop configuration is shown. If the instantaneous flow rate value measured by this instrument satisfies the upper and lower limit settings or a critical failure occurs in the instrument, that state is delivered as a contact output.

In addition to an analog signal, this loop configuration allows this instrument to deliver the contact output to a sequencer or other host control system.

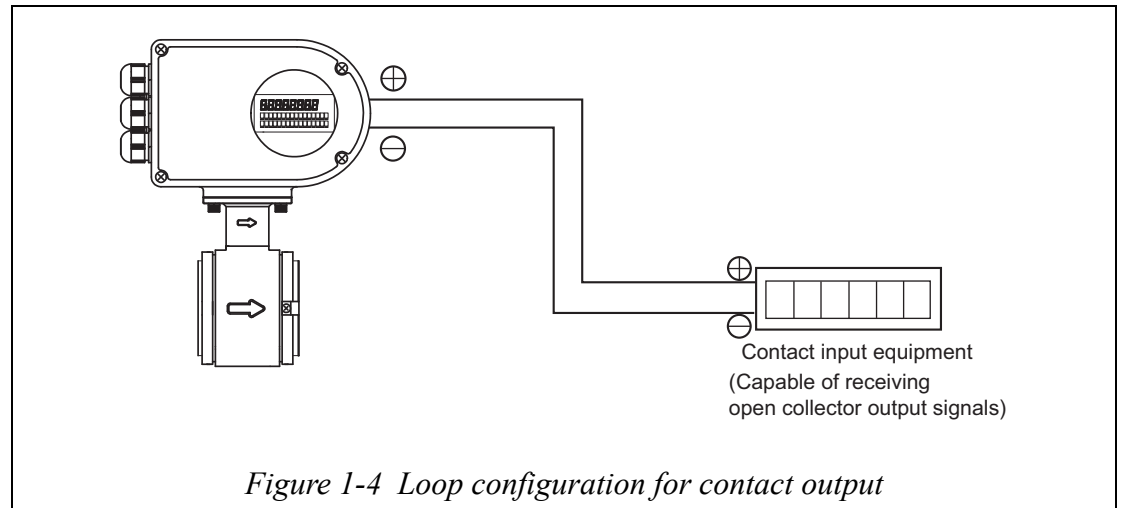

- Electromagnetic flowmeter (main unit): Measures flow rate and outputs an upper or lower limit alarm or critical failure as a contact output.
- Contact input equipment: Receives the contact output and displays the alarm and the like.
- Open collector: An output method using a transistor contact.

1-2 : Structure of this instrument and functions of its various parts

1-2-1 : Structure of main unit

Major components

This instrument consists of a detector and converter. The converter, in turn, consists of the converter proper, an indicator/data setter and a terminal box.

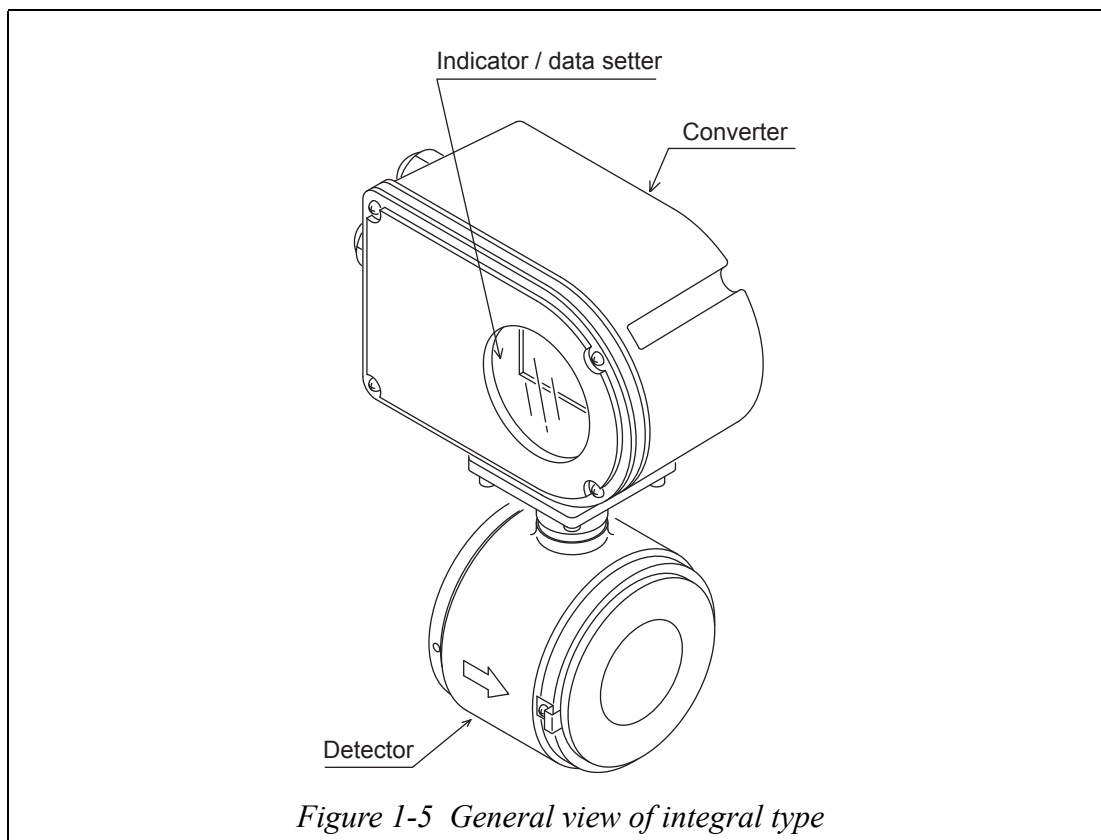

Names and description of various parts

The following table gives a description of the various parts.

Name	Description
Detector	<ul style="list-style-type: none"> • When a fluid passes through the inside, the sensor generates a signal of electromotive force that is proportional to the passing flow rate. • Installs to the pipes and supports the entire instrument. • The electrode mounting position is horizontal mounting for both electrodes.
Converter	<ul style="list-style-type: none"> • Transforms the signal of electromotive force generated by the sensor into an instantaneous flow rate value and outputs a flow rate signal. Equipped inside with a Terminal block.
Indicator/data setter	<ul style="list-style-type: none"> • Displays the instantaneous flow rate value and internal status of the instrument.

1-2-2 : Detector: Wafer type

Description

The wafer type detector has a function and structure as follows:

- When a fluid passes through the inside, the detector generates a signal of electromotive force that is proportional to the passing flow rate.
- The electrode mounting position is for horizontal mounting for both electrodes.

Names of various parts

The structure and names of various parts of the sensor are shown.

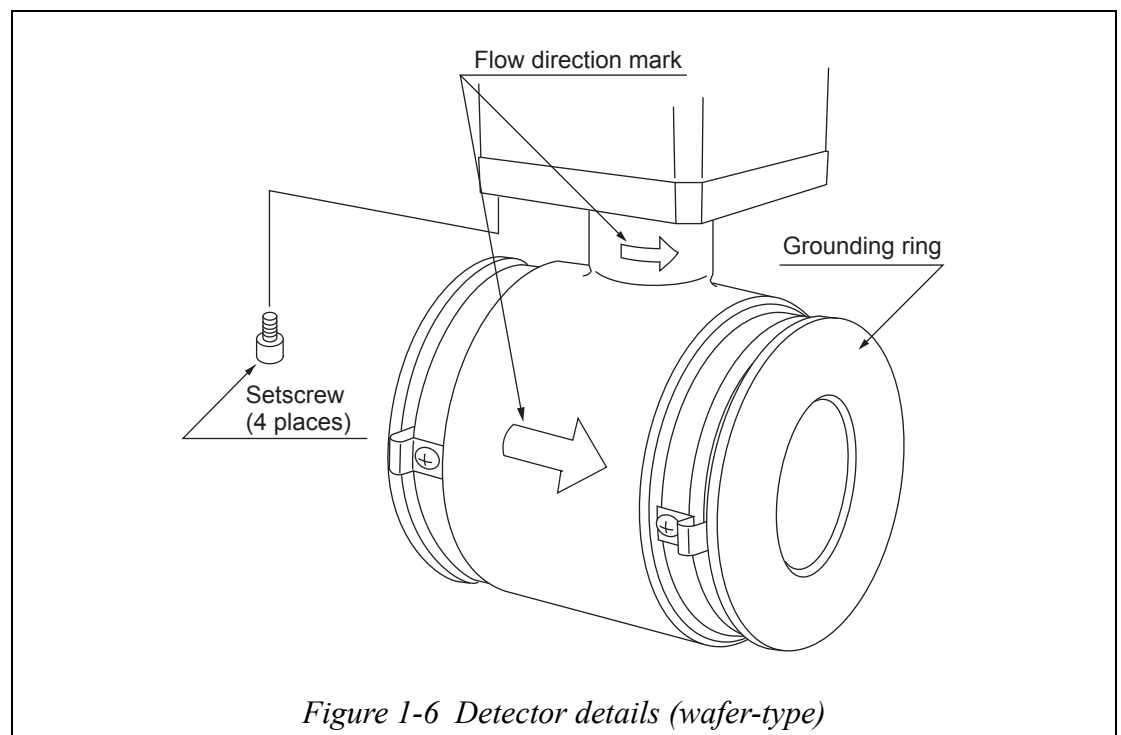

Names and functions of various parts

The following table describes the various parts of the detector.

Name	Description
Flow direction mark	<ul style="list-style-type: none"> • Indicates the flow direction of the fluid. • Install the detector and ensure that the fluid flow conforms to the flow direction mark.
Grounding ring	<ul style="list-style-type: none"> • Made of stainless steel

1-2-3 : Indicator/data setter

Description

The indicator/data setter has the following function and structure.

- Displays the instantaneous flow rate value and internal conditions of the instrument.
- The indicator face can be turned at intervals of 90 degrees through one turn.

Names of various parts

The names of various parts of the indicator/data setter are shown.

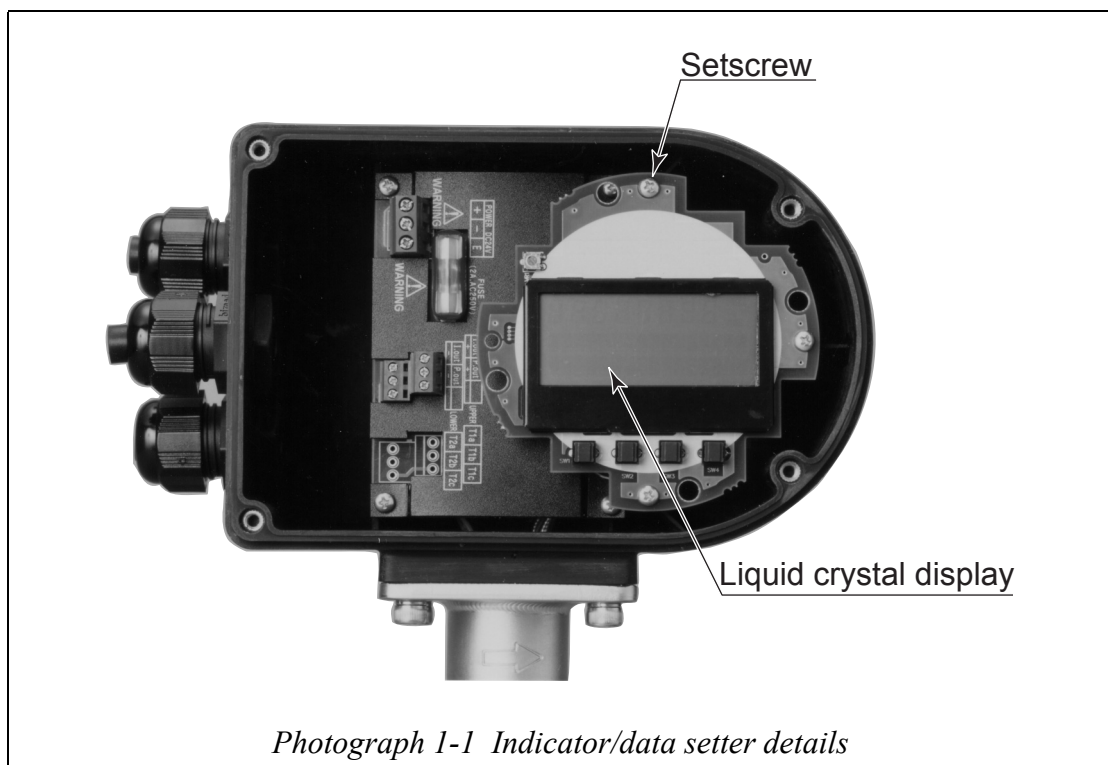

1-2-4 : Terminal block

Description

The terminal block contains output signal terminals. Open the transducer cover and you will find screwed miniature terminals on the left.

Names of various parts

The structure of the terminal block and the names of its various parts are shown.

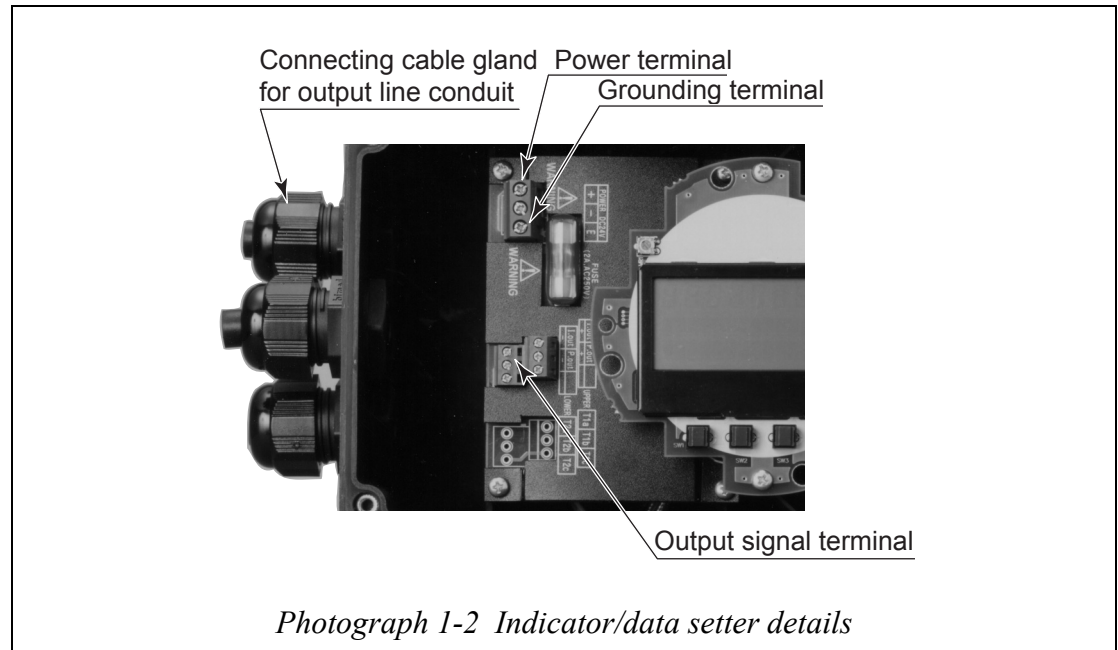

Names and description of various parts

The following table describes the various parts of the terminal box.

Name	Description
Transducer cover	<ul style="list-style-type: none"> • Jet-proof structure (JIS C0920)
Output signal terminal	<ul style="list-style-type: none"> • I.OUT+, -: Analog current output terminals • L: Power supply terminal. There are models for 24V DC and 100V AC. Check referring to the specification. • PULSE/STATUS OUT+, -: Open-collector pulse output and contact output terminals
Grounding terminal	<ul style="list-style-type: none"> • Make a single-point grounding (Class D) from the internal grounding terminal at a place as close to this instrument as possible. • The grounding should be JIS Class D. If not grounded, malfunctions can result. <div data-bbox="794 817 1204 1411" style="text-align: center;"> <p>Grounding resistance: less than 100Ω</p> </div>
Connecting cable gland for output signal line conduit	<ul style="list-style-type: none"> • Wire the signal line by entering it through this.

Chapter 2 : Instrument installation

Outline of this chapter

This chapter describes the installation and wiring of the instrument.

The necessary components and installing methods depend on the material of the grounding ring and the material of the installed piping.

The description proceeds in the following order:

- Criteria for selecting an installation environment
- Outline of installing method of the instrument
- Detailed installing methods by materials

2-1 : Before installation

2-1-1 : Criteria (1) for selecting an installation location

Introduction

To bring out the performance of this instrument to the maximum, choose the optimum installation location according to the following criteria for selecting an installation location.

Cautions on surrounding environment

- Install at a place where the ambient temperature is in the range from -20 to +50°C (-4°F to +122°F) and the ambient humidity is in the range from 10 to 85% RH. Otherwise, instrument failure or output errors may result.
- Avoid a place close to a large-current cable, motor or transformer that may bring about inductive interference. Otherwise, instrument failure or output errors may result.
- Avoid a place where there are severe vibrations or a corrosive atmosphere. Otherwise, a broken sensor neck or damaged instrument may result.
- Avoid a place exposed to direct sunlight. Otherwise, a broken plastic case may result.

Cautions on measured fluid

As to the measured fluid, install the instrument where it satisfies the following conditions. Otherwise, output errors or fluctuations may result.

- A place where the measured fluid has the necessary electric conductivity for measurement (the value depending on the transducer used in combination) and the conductivity distribution can be deemed almost even.
- A place where the measured fluid can be deemed electrochemically homogeneous. If, for example, fluids are mixed in the upstream pipe, a place where the two fluids can be deemed to have mixed together homogeneously.
- If an ingredient is mixed in, a place where the ingredient distribution can be deemed homogeneous.
- For the following fluids, do not use this instrument even if their electric conductivity, temperature, pressure and the like are within the instrument specifications (see Appendix) because they can cause problems in measurement.
 - (1) Fluids which have a sufficient conductivity at high temperatures but do not satisfy the conductivity requirement at ordinary temperature (about 20°C (68°F)). (For example, fatty acids and soap)
 - (2) Some fluids with a surfactant mixed in (For example, rinse, shampoo and CWM)
 - (3) Insulating adhesive materials (For example, oil, kaolinite, kaolin, calcium stearate)
 - (4) Slurry fluids containing solid matter (For example, pulp slurry, mud slurry, cement slurry)

Cautions after installation** CAUTION**

- (1) Avoid using this instrument as a foothold after installation because such a use may cause injury or damage to the equipment.
- (2) Take care when using a hand tool. An impact from the tool may cause a broken case, resulting in injury.

 WARNING

- (1) When removing this instrument, do removal work after ascertaining that there is no residual liquid or pressure in the pipe or inside the sensor. Otherwise, you may be injured.

- The output signal or indication may fluctuate depending on pulsation or other conditions of the fluid. In such cases, increase the damping time constant or take some other measure.

2-1-2 : Criteria (2) for selecting an installation location

Installed position

- Install the instrument at a place where the measured fluid always fills inside the sensor. An example of installation is shown in the figure below to illustrate this condition.

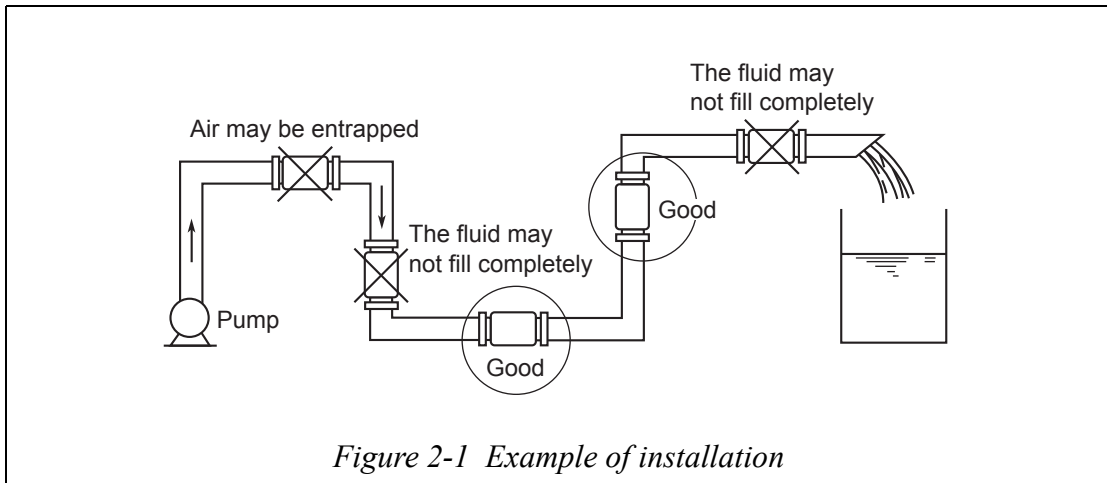

- ~Note**
- ***Install the instrument under the conditions circled in the figure above with the detector full of fluid. If the sensor is not filled in full, output errors may result. If empty, output fluctuations may result.***
 - *If the measured fluid is highly viscous, we recommend installing the instrument on a vertical pipe and flowing the fluid to ensure an axially symmetrical flow.*
 - *Lay on a straight pipe section upstream and downstream of the installation location. For the straight section length, see the figure below*

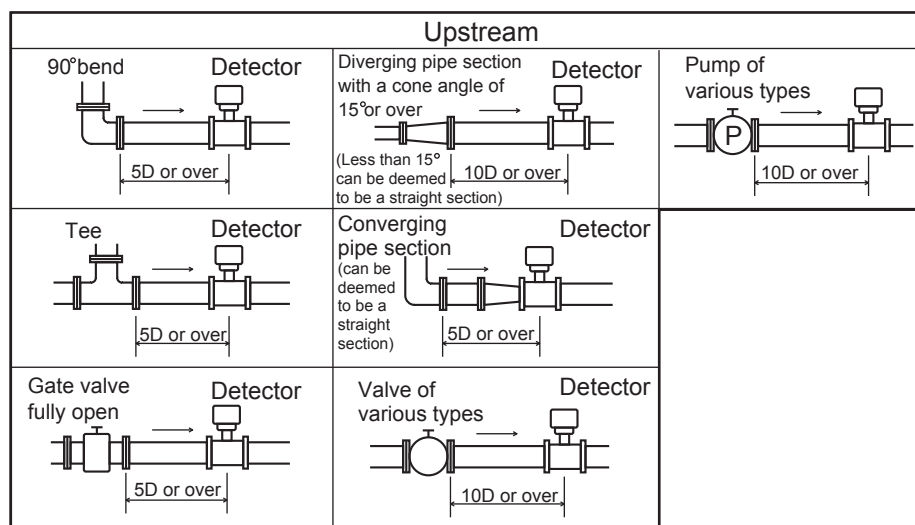

*Figure 2-2 Straight pipe section upstream of detector
(D: Nominal detector bore diameter)*

- No straight pipe section is basically needed on the downstream side. However, ensure 2D or over if influences of drift are thought possible.
- Choose a place where there are little pulsations in the flow (install at a place sufficiently distant from a pump or the like).
- Ensure the necessary space for inspecting the terminal box.

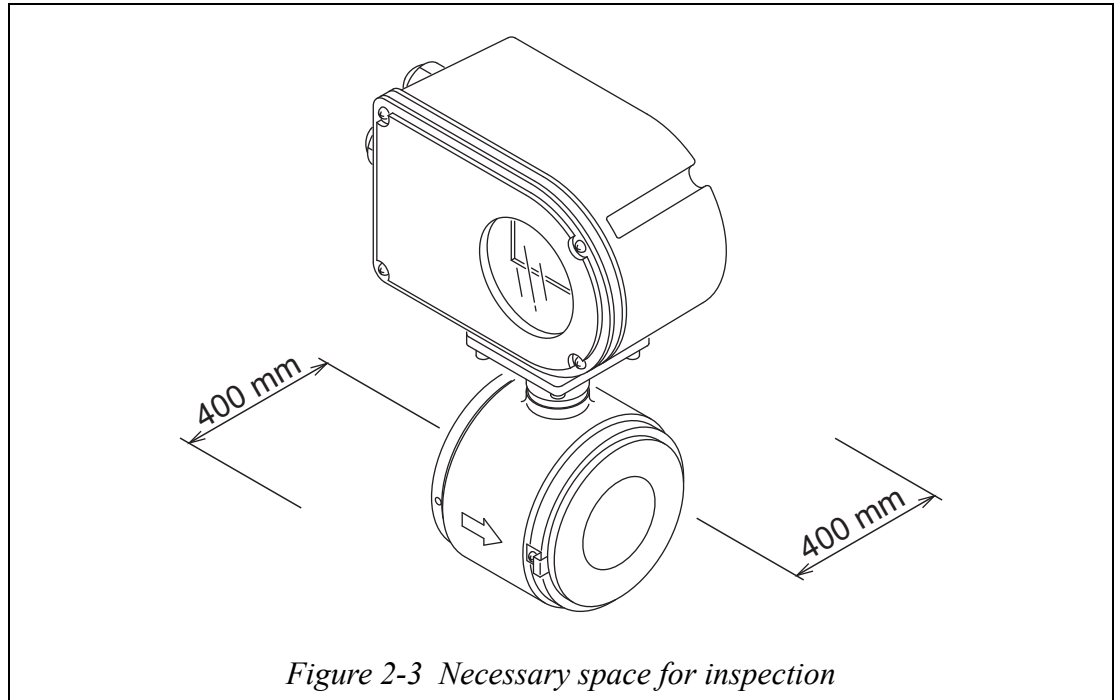

2-1-3 : Direction of indicator/data setter

Changing the indicator/data setter direction

The indicator/data setter can be changed to a horizontal or vertical direction.

Step	Procedure
1	Power off the converter. For the power-off, use the circuit breaker or the like.
2	The converter front cover is fixed by hexagon socket head setscrews (M3). Loosen the setscrews with an Allen wrench (1.5).
3	Remove the converter front cover by turning it counterclockwise with the dedicated tool. ~Note <i>Remove the front cover straight toward you with care.</i>
4	The indicator/data setter is fixed by three screws. Remove these screws. ~Note <i>The screws are not captive to the indicator/data setter, so take care not to drop them.</i>
5	Remove the indicator/data setter. ~Note <i>A cable is attached to the rear of the indicator/data setter. This cable is connected to the connector of the converter proper.</i>
6	Turn the indicator/data setter to the desired direction and align it to the threaded holes in the converter proper.
7	Fix the indicator/data setter again using the three screws. ~Note <i>When tightening the screws, take care not to entangle and squeeze the cable.</i>
8	Attach the front cover. ~Note <i>Take care not to injure your fingers on the cover edge or the thread in the case.</i>

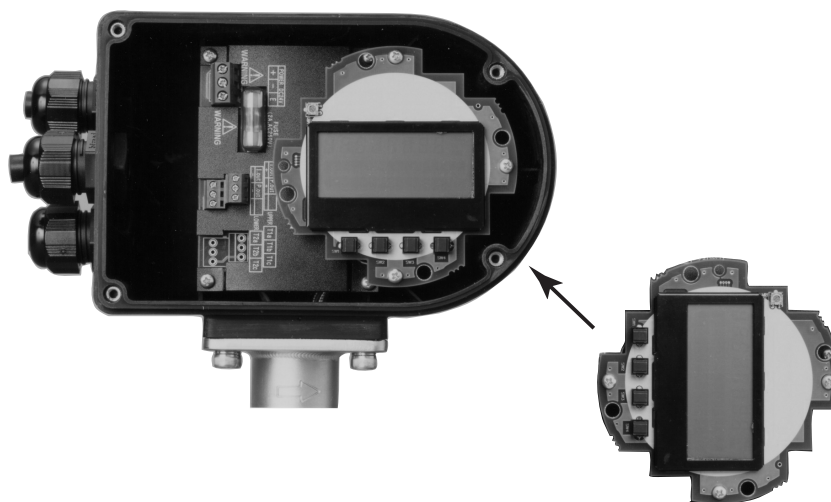

Figure 2-4 Changing the indicator/data setter direction

2-1-4 : Direction of the converter

Introduction

In some locations, the direction of the converter may be unsuitable if the detector is installed as it is shipped. In such a case, the converter can be repositioned.

After selecting an installation site, adjust the direction of the converter in advance by the method shown below.

Repositioning the converter

The converter can be repositioned at right angles. Follow the procedure below.

Step	Procedure
1	Using an M5 hex wrench, remove the four screws securing the converter.
2	Holding the detector, rotate the converter horizontally to the desired position. <div style="border: 1px solid black; padding: 5px; margin: 5px 0;"> <p style="text-align: center;">⚠ CAUTION</p> <p>Do not rotate the unit more than 180° (one half rotation). Any greater rotation can break wiring parts. If the converter is removed, make sure that the O-ring, which provides an air-tight seal, is still fitted into the O-ring groove.</p> </div>
3	Using a hex wrench, re-tighten the four screws to secure the converter.

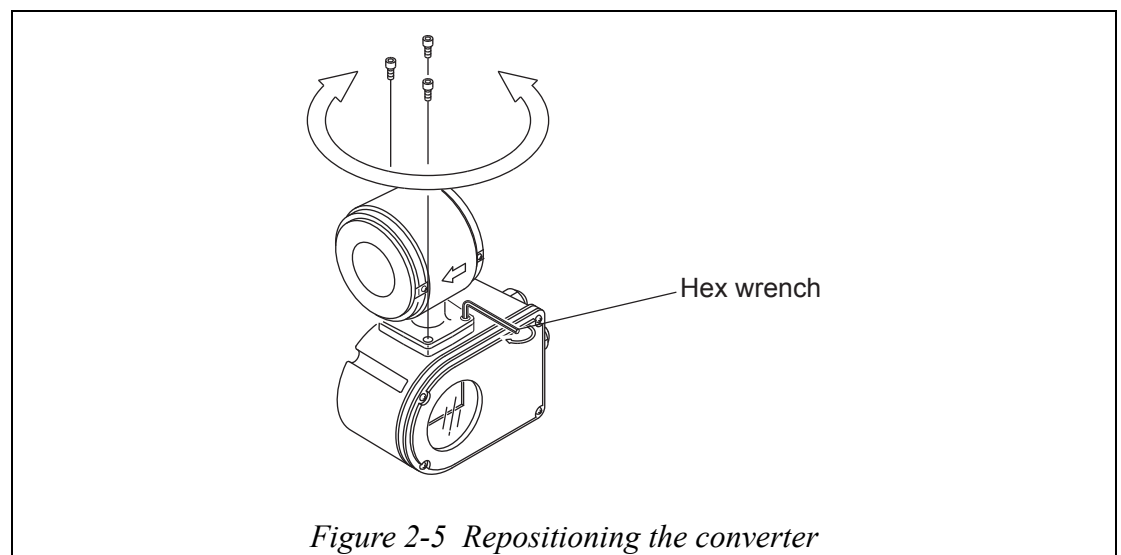

⚠ CAUTION

After removing the screws, do not pull hard on the converter. Otherwise, the lead wire inside can break.

2-2 : Installation method

2-2-1 : Installation of wafer-type detector

Basic installing method

Introduction

This instrument is capable of wafer-type mounting. Install it correctly referring to the appropriate installing method.

Example of installing the wafer-type detector

The basic installing method of the wafer-type detector is shown.

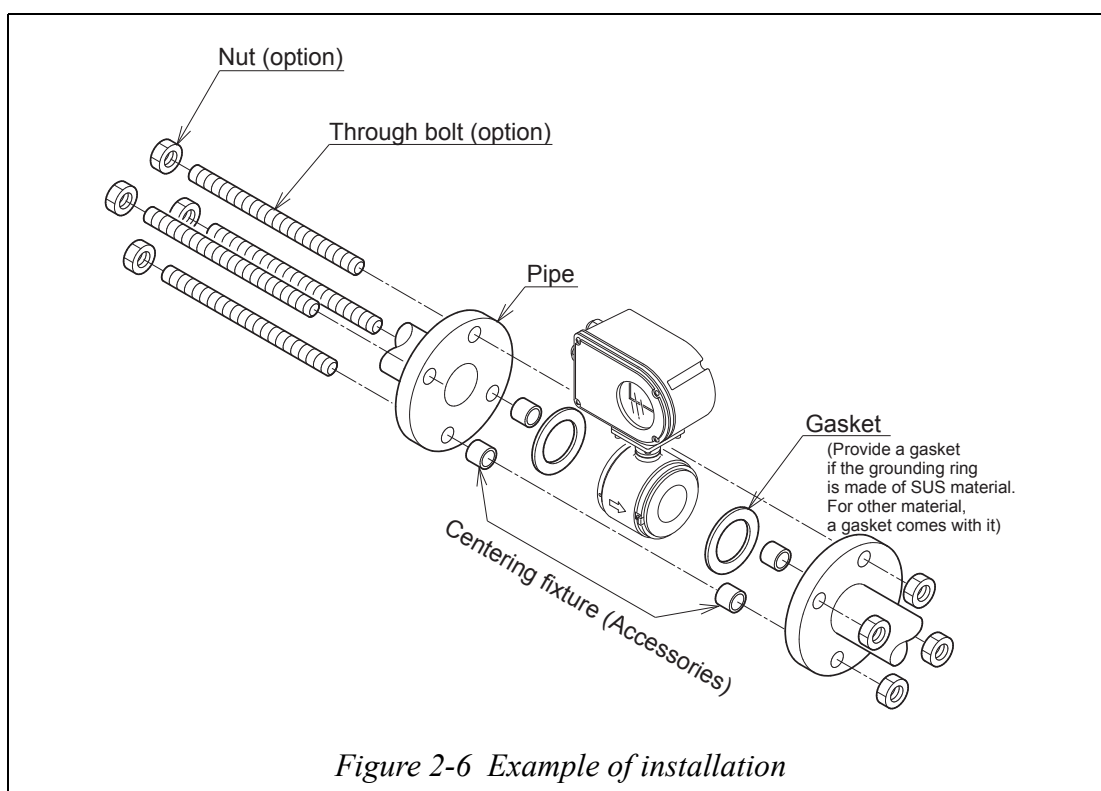

⚠ CAUTION

This instrument is heavy. Dropping it on your foot may cause injury or bone fracture. Take due care.

Tightening torque

⚠ CAUTION

Table 2-1 shows the tightening torques by bore diameters. To prevent leakage from the pipe, use the centering fixtures and fix with the prescribed tightening torque. A leakage would bring about the danger of injury.

Table 2-1 Tightening torque

Nominal bore diameter of sensor	Tightening torque
15 mm	13 - 18 N•m (130 - 180 kgf•cm)*
25 mm	20 - 30 N•m (200 - 300 kgf•cm)*
40 mm, 50 mm, 65 mm, 80 mm	30 - 50 N•m (300 - 500 kgf•cm)*
100 mm	50 - 70 N•m (500 - 700 kgf•cm)*

*: Values in parentheses are for information only.

Flange shape

Referring to Figure 2-7, use a flange that gives a large area of contact with the gasket.

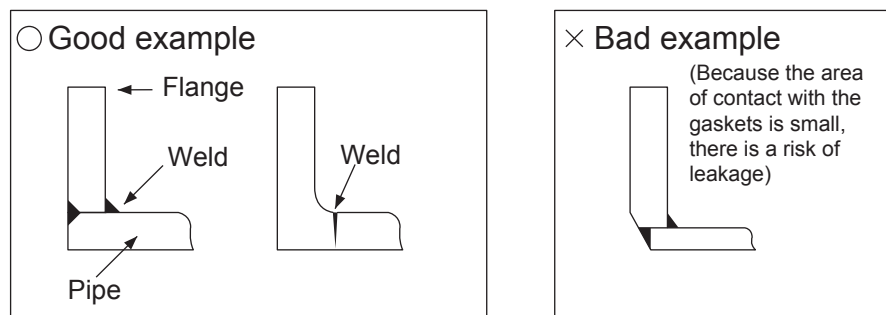
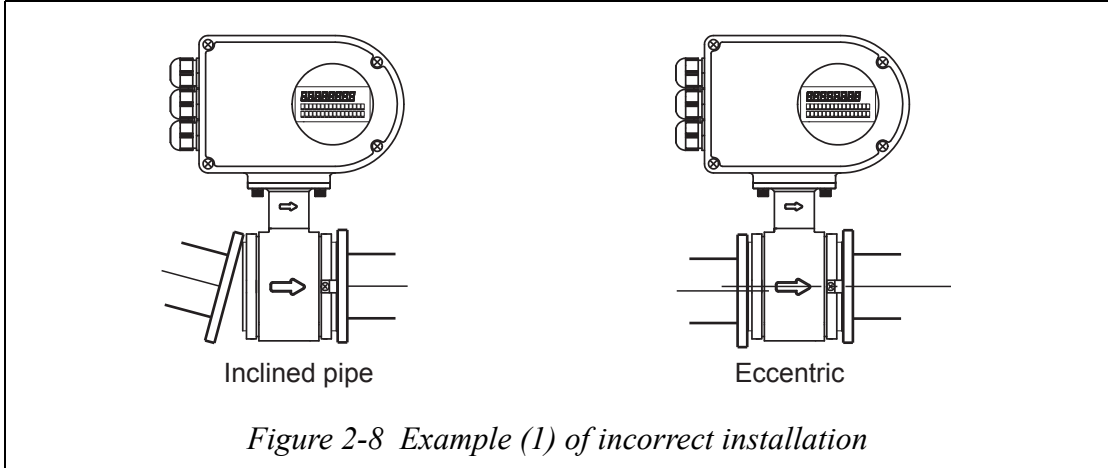

Figure 2-7 Flange shape

- ~Note**
- Prior to installing the detector, always do flushing (washing of pipe) to remove foreign matter inside the pipe. Otherwise, output fluctuations may result.
 - Do not touch the electrodes with your hand, an oily rag or the like. Otherwise, output fluctuations may result.
 - Make the flow direction mark of the detector agree with the direction of the fluid flow. In case of disagreement, no output will be delivered.

⚠ CAUTION

Install after confirming that there is no inclination or eccentricity of the pipe. Otherwise, leakage or the like may result and the danger of injury may be brought about.



~Note *Do not insert between flanges that are too close together by force. Otherwise, the instrument may be broken.*

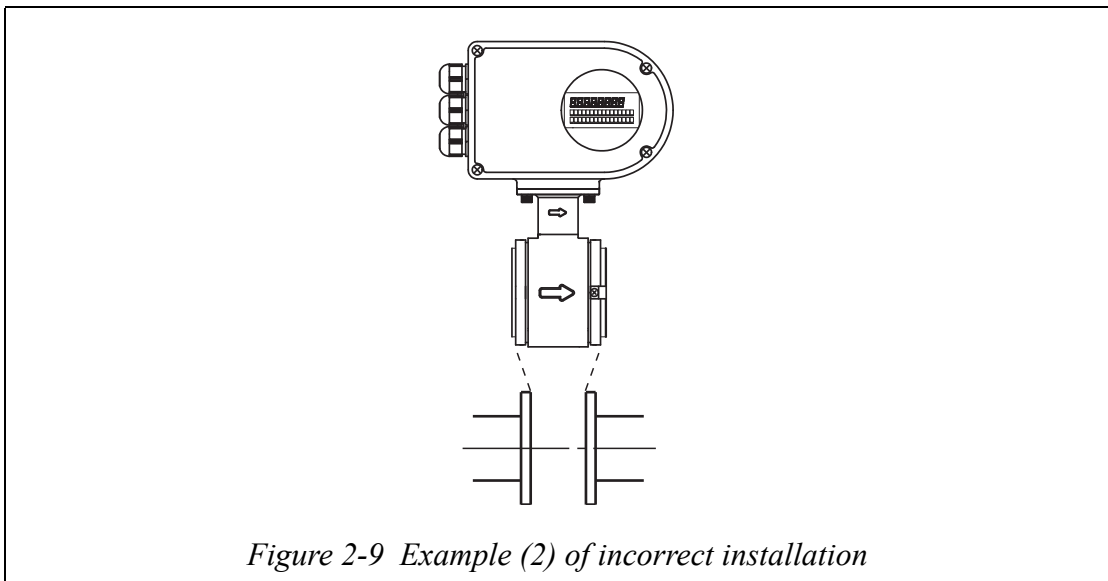

⚠ CAUTION

When installing, align the bores of the detector and pipe so that the gasket does not stick out inside the pipe. Otherwise, a leakage may result and the danger of injury may be brought about.

~Note *When tightening the bolts, proceed with the tightening work so that the bolt tightness increases evenly over the bolts. If fluid leakage does not stop after tightening, check for misalignment and gradually increase the tightening bolt. When installing, take care that the tightening bolt is within the prescribed limit. Otherwise, damaged equipment may result.*

Components necessary for installation

Introduction

For installing the sensor, the following components are required:

- Centering nuts (4 pieces)
- Through bolts and nuts (optional)
- Gasket: Provide yourself.
- Protective plate: May be needed when installing the sensor on PVC pipe.

Centering fixtures

When installing, use the centering fixtures to prevent misalignment between the pipe and sensor.

Pass bolts through the centering fixtures so that the detector rests on or in-between the fixtures.

The attaching position of the fixtures used depends on the mounting direction of the detector.

For the attaching position, see the following figures.

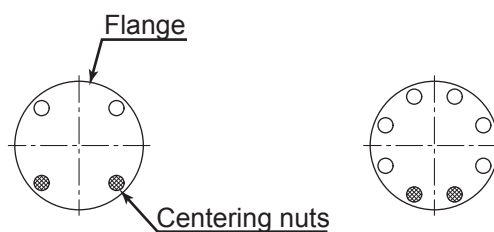

*Figure 2-10 Horizontal mounting
(Attach two pieces to each of the right and left flanges.)*

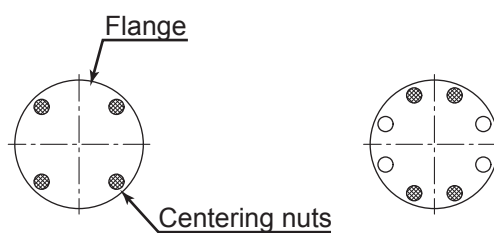

*Figure 2-11 Vertical mounting
(Attach 4 pieces to the lower flange.)*

Gasket

The recommended gasket materials are joint sheet and PTFE. For the gasket internal diameter, follow Table 2-2. We do not recommend rubber materials, but if you use them, follow the following precautions:

- ~Note
 - *Too small a gasket internal diameter may disturb the velocity distribution and have an adverse effect on the accuracy.*
 - *Too large a gasket internal diameter may bring about fluid leakage. In the case where solid materials are contained in the measured fluid, accumulations of the solid materials may cause between a gasket and a flange and have an adverse effect on the accuracy.*

Table 2-2 Recommended gasket internal diameter of full-face gaskets (Unit: mm)

Bore diameter Size	15 mm (1/2 inch)	25 mm (1 inch)	40 mm (1½ inch)	50 mm (2 inches)	65 mm (2½ inches)	80 mm (3 inches)	100 mm (4 inches)
Internal diameter	16.5 ±1	25.5 ±1	40.5 ±1	52 ±1	65 ±1	79 ±1	104 ±1

If you use rubber gaskets and install with a small tightening torque, provide rubber gaskets with the inner and external diameters shown in Table 2-3.

For some grounding ring materials, two rubber gaskets of different thickness are required. (See Figure 2-15 on page 2-19.)

Table 2-3 Internal and external diameter of rubber gaskets 0.5 to 1 mm thick (Unit: mm)

Bore diameter Size	15 mm (1/2 inch)	25 mm (1 inch)	40 mm (1½ inch)	50 mm (2 inches)	65 mm (2½ inches)	80 mm (3 inches)	100 mm (4 inches)
Internal diameter	16.5 ±1	25.5 ±1	40.5 ±1	52 ±1	65 ±1	79 ±1	104 ±1
External diameter	34 ±1	50 ±1	75 ±1	91 ±1	111 ±1	121 ±1	146 ±1

Table 2-4 Internal and external diameter of rubber gaskets 3 to 4 mm thick (Unit: mm)

Bore diameter Size	15 mm (1/2 inch)	25 mm (1 inch)	40 mm (1½ inch)	50 mm (2 inches)	65 mm (2½ inches)	80 mm (3 inches)	100 mm (4 inches)
Internal diameter	16.5 ±1	25.5 ±1	40.5 ±1	52 ±1	65 ±1	79 ±1	104 ±1
External diameter	34 ±1	50 ±1	68 ±1	84 ±1	104 ±1	114 ±1	139 ±1

Selecting an installing method

CAUTION

The necessary components and installing method depend on piping material. On confirmation of the specifications and installation conditions of the sensor to be installed, choose the appropriate installing method. A wrong installation may bring about leakage of the measured fluid or damage to the pipe flanges, resulting in injury.

Selecting an installing method by material

Choose the appropriate installing method according to the following table.

Material of pipe on which to install	Material of grounding ring	Page to refer to
Metal	SUS material	Page 2-17
PVC	SUS material	Page 2-18

Installing method on a horizontal pipe

⚠ CAUTION

An incorrect installation may bring about leakage of the measured fluid or damage to the pipe flanges, resulting in injury.

Necessary components

Provide the following components:

- Through bolts and nuts
- Centering fixtures
- Gaskets: Different pieces required depending on the material of the pipe on which to install the sensor. See the installing methods by pipe material on pages 2-17 to 2-18.

Procedure

Follow the following:

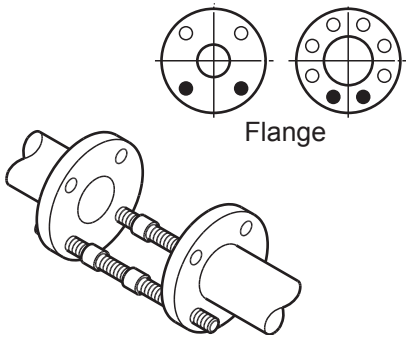
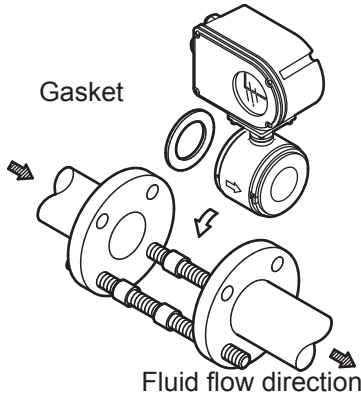
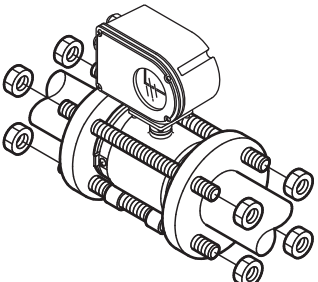
Step	Description	Figure
1	Pass bolts through the flange holes represented by black circles in the figure. In this occasion, put two centering fixtures on each bolt.	 <p style="text-align: center;">Flange</p>
2	<ul style="list-style-type: none"> • Make the flow direction mark on the instrument agree with the fluid flow direction. • Insert the detector together with gaskets between the flanges. • See that the detector rests on the centering fixtures. 	 <p style="text-align: center;">Fluid flow direction</p>
3	<ul style="list-style-type: none"> • Check for misalignment. • Check the gaskets for flushness. • On completion of these checks, pass the remaining bolts through the flange holes and tighten all bolts evenly with the tightening torque on page 2-9. 	

Installing method on a vertical pipe

⚠ CAUTION

A wrong installation may bring about leakage of the measured fluid and damage to the pipe flanges, resulting in injury.

Necessary components

Provide the following components.

- Through bolts and nuts
- Centering fixtures
- Gaskets: Different pieces required depending on the material of the pipe on which to install the sensor. Refer to the installing methods by pipe material on pages 2-17 to 2-19.

Procedure

Follow the following:

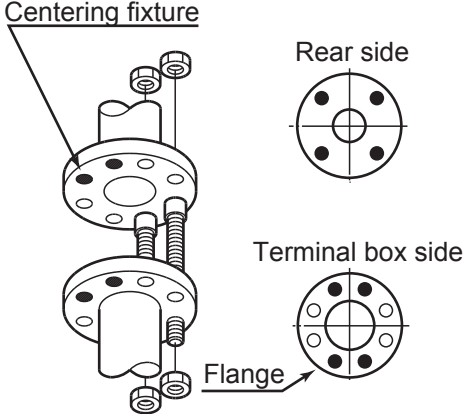
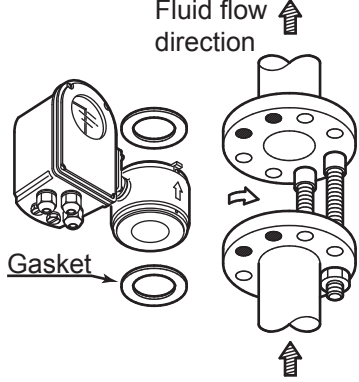
Step	Description	Figure
1	The flange holes are represented by black circles. Pass bolts through the 2 rear holes and lightly fix them with nuts. In this occasion, put one centering fixture on each bolt.	
2	<ul style="list-style-type: none"> • Make the flow direction of the instrument agree with the fluid flow direction mark. • Insert the sensor together with gaskets between the flanges. 	

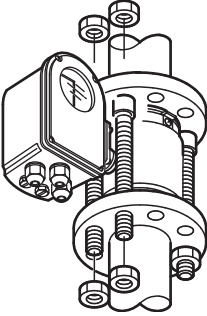
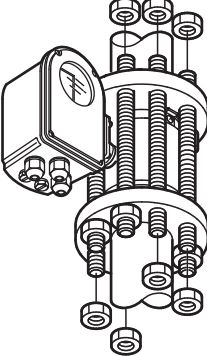
Step	Description	Figure
3	<p>Pass bolts through the remaining two flange holes represented by black circles in Steps 1 and 2, with a centering fixture put on, and lightly fix them.</p>	
4	<ul style="list-style-type: none"> • Check for misalignment. • Check the gaskets for flushness. • On completion of these checks, pass the remaining bolts through the other flange holes and tighten all the bolts evenly with the tightening torque on page 2-9. 	

Installing method (1) on a metallic pipe

Introduction

The installing method shown on this page is applicable to the following combination of pipe and grounding ring materials. For installing methods applicable to other combinations, refer to the table on page 2-13.

Pipe: Metal

Grounding ring: SUS material

Necessary components

Provide the following components:

- Through bolts and nuts
- Centering fixtures
- Gaskets: The recommended gaskets are gasket made of PTFE or rubber.

Recommended gasket internal diameter: Refer to Table 2-2 on page 2-12.

Installing

- Install as shown below.

For the tightening torque, follow Table 2-1 on page 2-9 irrespective of gasket material. For the gasket internal diameter, follow Table 2-2 on page 2-12.

⚠ CAUTION

When rubber gaskets are used, the tightening torque must be small. However, this may give rise to an insufficient surface pressure between the lining and grounding ring, resulting in fluid leakage and injury.

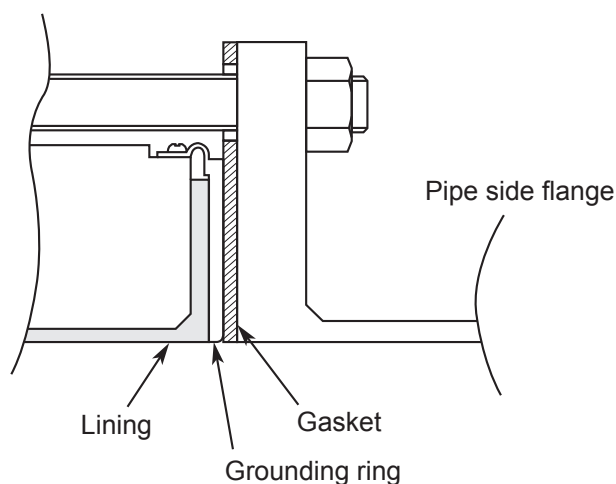

Figure 2-12 Grounding ring of SUS material

Installing method (1) on a polyvinyl chloride pipe

Introduction

The installing method shown on this page is applicable to the following combination of pipe and grounding ring materials. For installing methods applicable to other combinations, refer to the table on page 2-13.

Pipe: Polyvinyl chloride (PVC)

Grounding ring: SUS material

Necessary components

- Provide the following components:
 - Through bolts and nuts
 - Centering fixtures
 - Gaskets: The recommended gaskets are gaskets made of PTFE or rubber.
 - Recommended gasket internal diameter: Refer to Table 2-2 on page 2-12.
 - If rubber gaskets are used, additional gaskets are required. The gaskets should be 0.5 to 1 mm thick and of the same material as the provided rubber gaskets. For the dimensions, refer to Table 2-3 on page 2-12.
 - Protective fixtures: Needed if installing with the prescribed tightening torque gives rise to a threat of deformation of, or damage to, the PVC pipe. Use stainless steel or other metallic material 6 mm thick or more that will not deform when the nut is tightened. For the fixture shape, see Figure 2-14.

Installing method

The installing method depends on the amplitude of the tightening torque, existence or nonexistence of protective fixtures and other conditions. Install according to the applicable conditions.

1. Installing with the prescribed tightening torque

Install as shown below.

For the tightening torque, follow Table 2-1 on page 2-9 irrespective of the gasket material. The gasket internal diameter should conform to Table 2-2 on page 2-12.

⚠ CAUTION

When rubber gaskets are used, the tightening torque must be small. However, this may give rise to an insufficient surface pressure between the lining and grounding ring, resulting in fluid leakage and injury.

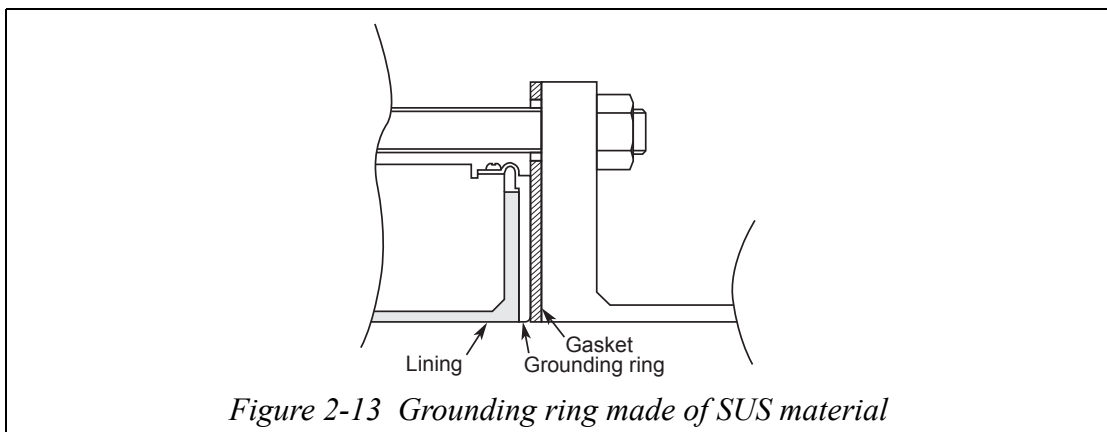
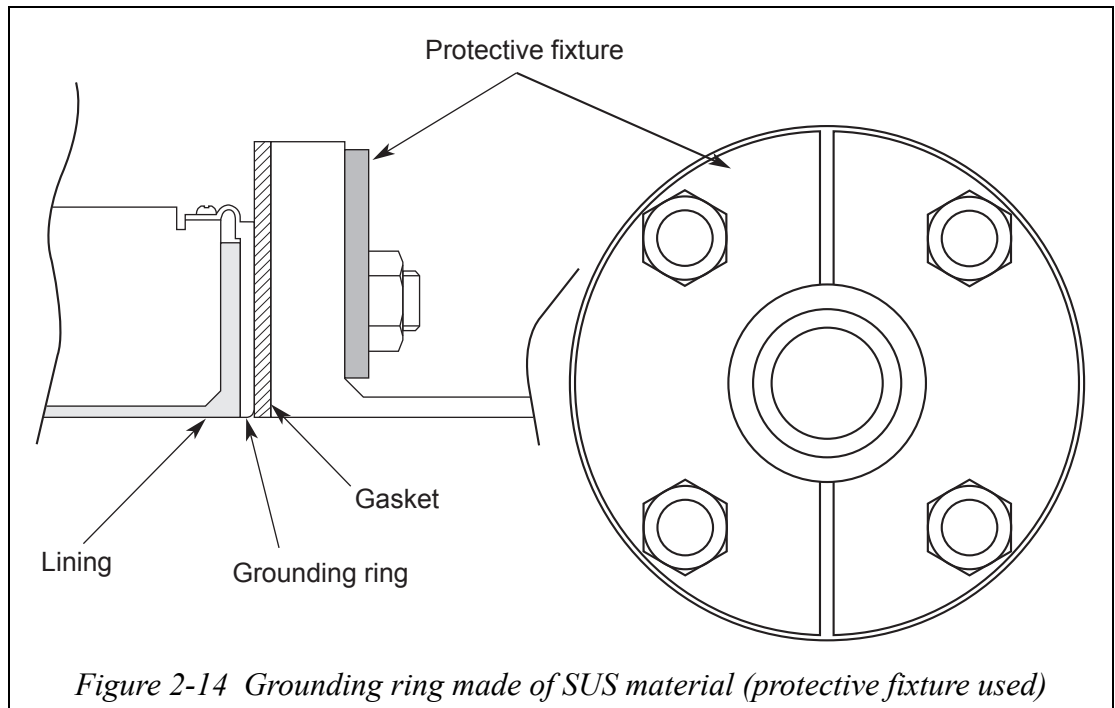
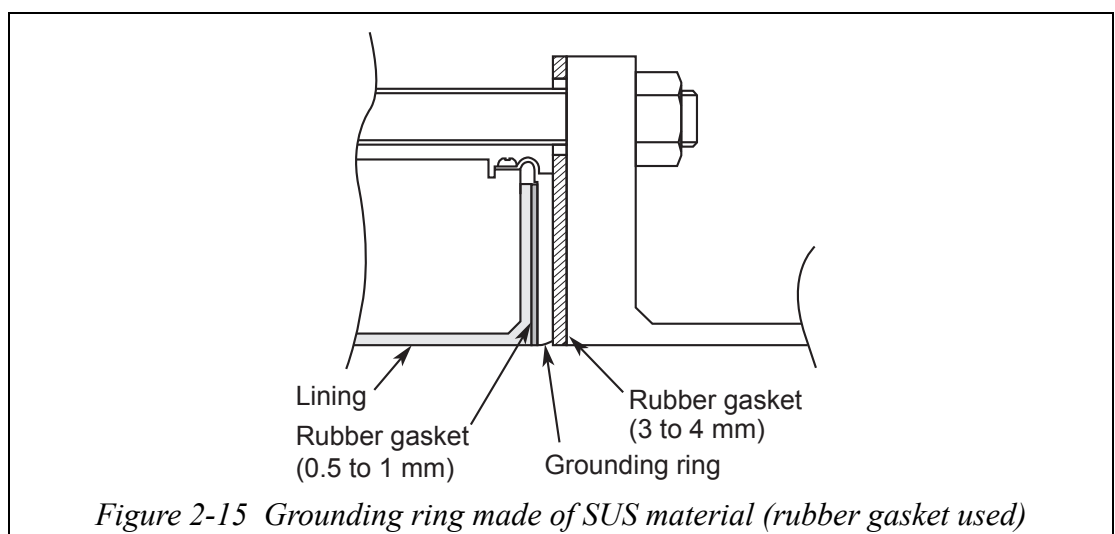

Figure 2-13 Grounding ring made of SUS material

2. In the case where installing with the prescribed tightening torque gives rise to a threat of deformation of, or damage to, the PVC pipe (protective fixture used) Provide a protective fixture that can be attached to the outside of the PVC flange and will not deform or damage the pipe when the prescribed tightening torque is applied. Attach the protective fixture to the PVC flange and install the detector as shown below. The tightening torque should conform to Table 2-1 on page 2-9 irrespective of the gasket material.



3. In the case of installing with a small tightening torque (rubber gasket used) Remove the grounding rings from the sensor and insert a rubber gasket 0.5 to 1 mm thick between the lining and grounding ring. Then, fix the grounding ring again. In this condition, install the sensor to the pipe using the provided rubber gaskets (3 to 4 mm thick). The tightening torque to be applied is the torque necessary for the liquid seal of the rubber gasket. In this case, use the two kinds of gaskets of the same material.



Chapter 3 : Electrical wiring

Outline of this chapter

This chapter describes the electrical wiring of the main unit.

3-1 : Electrical wiring

3-1-1 : Electrical wiring

Introduction

For this instrument to run, 24V DC or 100V AC power wiring is required. The electrical wiring of this instrument is described below as to the following items:

- Wiring cable connecting positions
- Power source and load resistance
- Cable selection and laying
- Grounding
- Wire connection of power source and analog current output
- Wire connection for pulse output
- Wire connection for contact output
- Wiring procedure

~Note *Do not connect commercial power directly to this instrument. Impressing commercial power on this instrument causes unrecoverable damage to the internal measuring circuit.*

Power and load resistance

Use power of 24V DC $\pm 10\%$ or 100V AC according to the specification.

The ripple of the supply power should be 1V or less in peak-to-peak value.

The wire to connect to the loop should have a load resistance of 400 Ω or less.

For a sequencer or other applications that do fast analog/digital conversion of 4-20 mA, insert the following additional network in parallel with the load resistance:

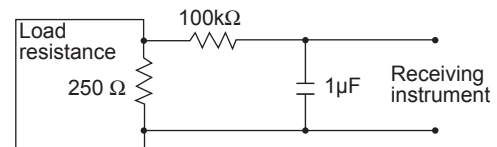

Wiring cable laying

When laying a cable between the instrument and a controller, pay attention to the following:

- The wiring should avoid a large-capacity transformer, motor, power source or other noise source. Do not put the cable in the same tray or duct together with other power cables.
- For waterproofing and wire covering damage prevention, we recommend wiring work using conduits and ducts.

Grounding

Grounding should be from the terminal E. Grounding resistance should be less than $100\ \Omega$. For the purpose of grounding, make sure to use 3 core cable for power supply cable.

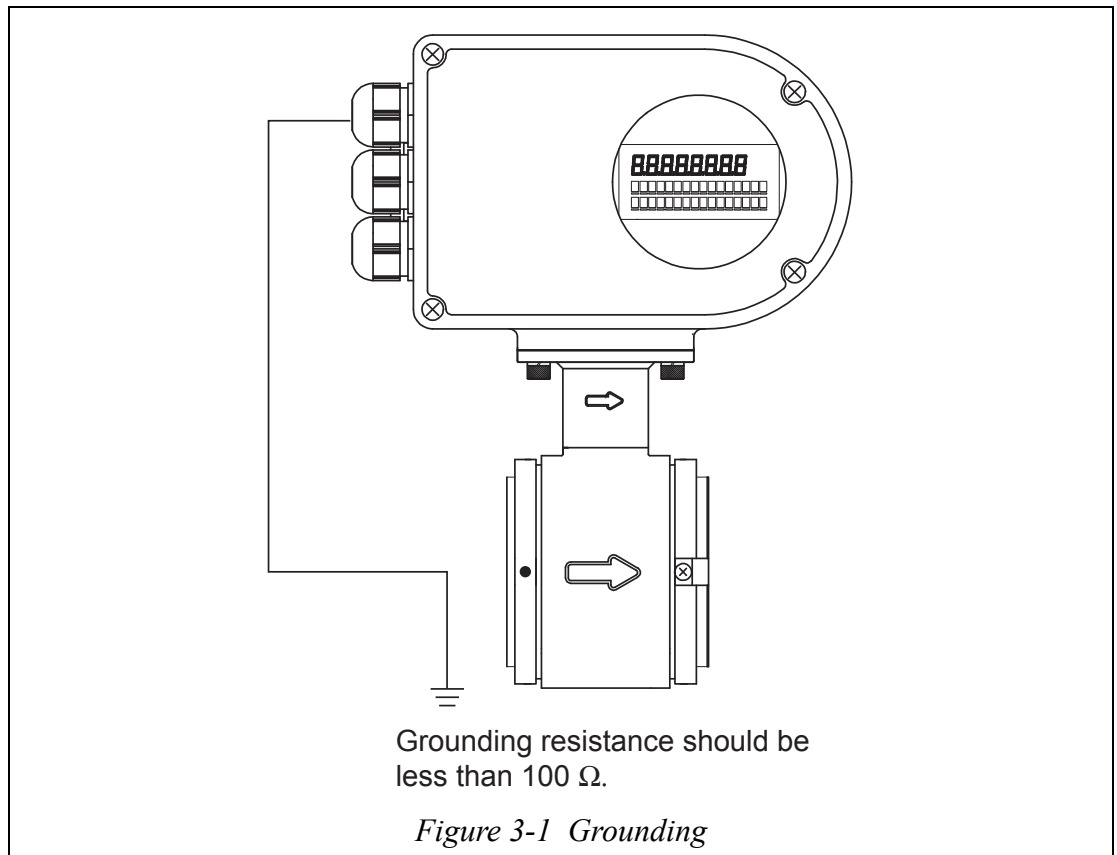

Wiring precautions

⚠ CAUTION

Incorrect wiring polarity can do damage to the equipment. Reconfirm the wiring position.

Wire connection of power supply and analog current output

Wire connection	Terminal	Applicable conductor diameter	Applicable cable diameter	Recommended cable
Power supply	+/L -/N	AWG14-22	6-12 mm	3-core CVV cable 2.0 mm ²
Power grounding	E	AWG14-22	6-12 mm	3-core CVV cable 2.0 mm ²
Analog output	Iout+	AWG16-26	6-12 mm	2-core KEVS cable
	Iout-	AWG16-27		
Pulse output	Pout+	AWG16-28	6-12 mm	2-core KEVS cable
	Pout-	AWG16-29		

Wire connection for pulse output

The pulse output is an open-collector output.

Do wiring work paying attention to the voltage and polarity.

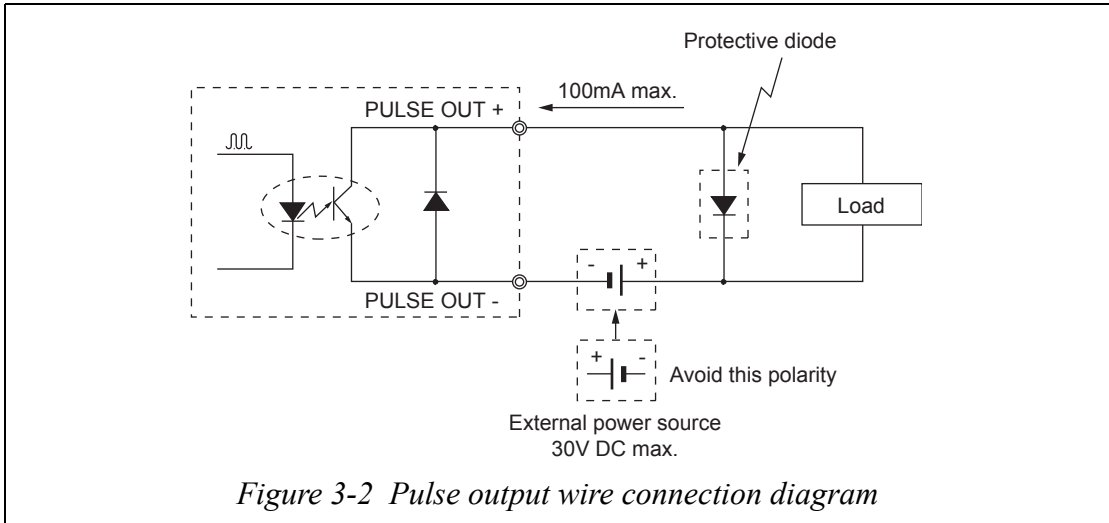

Wire connection for contact output

Because of the open-collector output, do wiring work paying attention to the voltage and polarity.

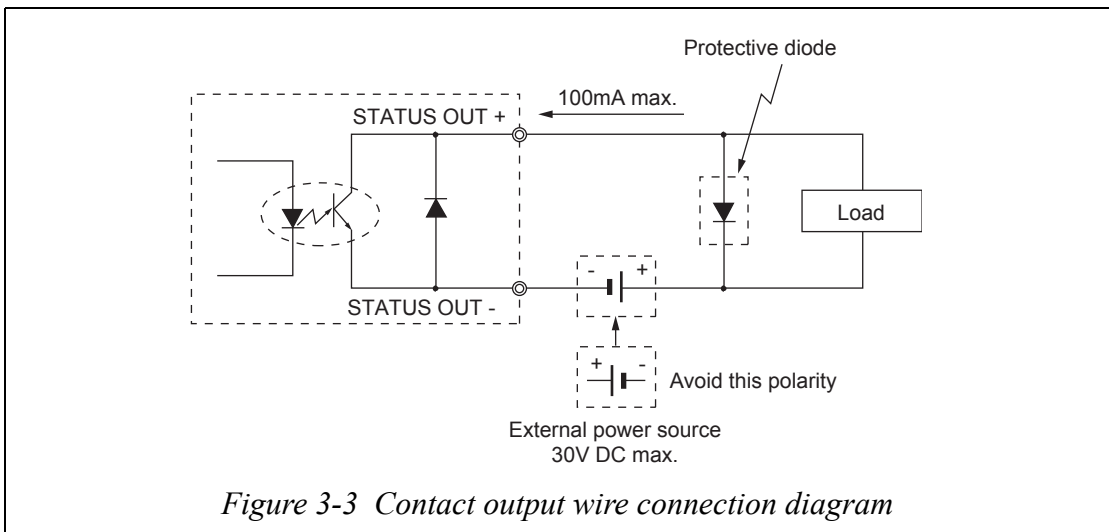

Chapter 4 : Operation

Outline of this chapter

This chapter describes the procedure for start-up of the instrument and making zero adjustment.

It also describes termination of the measuring system.

When starting up and operating the instrument for the first time, carefully follow the descriptions in this section.

4-1 : Confirmation before start-up

Introduction

Before you start to operate the system, confirm the following. Numbers in parentheses indicate the section to which to refer.

- (1) Confirm that the electromagnetic flowmeter is installed correctly to the pipe (Chapter 2 : Instrument installation).
- (2) Confirm that the electrical wiring is correct (Chapter 3 : Electrical wiring).
- (3) Fill the electromagnetic flowmeter detector with a fluid and make zero adjustment in a static state (Chapter 5 : Operation using the data setting device).
- (4) Confirm that there is no leakage at the joint of the electromagnetic flowmeter detector (Chapter 2 : Instrument installation).
- (5) Confirm that the electromagnetic flowmeter detector is filled with water and there are no stagnant bubbles in it.
- (6) Turn on power and warm up for 30 minutes.
- (7) Confirm whether the settings are in accordance with the data sheet inserted in the transducer. If there is a need to change settings to meet your usage, change them by the data setter or the like.

- ~Note**
- *If the detector is not filled with water or many bubbles have adhered inside, the flow rate indication may not reach zero. In such cases, force the water to flow once at the intended flow rate to ensure that the sensor is free of bubbles and filled with water.*
 - *With incorrect grounding, the indication of flow rate may fluctuate largely. In such cases, check the grounding condition.*

4-2 : Stopping

- ~Note** *When stopping the instrument from operation and shutting down the output to control equipment, always change over the control equipment to manual control. This operation is for preventing the shutdown of instrument output from exerting a direct influence on the control equipment.*

Procedure

When stopping the instrument, follow the following procedure:

Step	Procedure
1	Change over the control equipment of this instrument to be stopped to manual control.
2	Turn off the power.

Chapter 5 : Operation using the data setting device

This section describes how to operate this system from the data setting device. This system configuration and settings can be made using the four keys on the data setting device.

5-1 : Startup

Introduction

With the model MCB10A, all settings can be configured from the data setting unit.

Startup

When the power supply is turned on, the display changes in the order of OVERALL DISPLAY, SELF CHECK MODE, and MEASURING MODE.

OVERALL DISPLAY

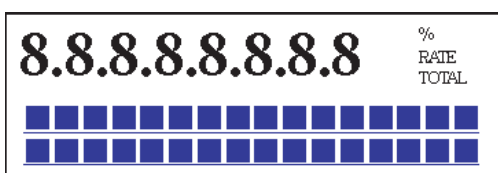

8.8.8.8.8.8.8.8
 Main display 7-segment, 8-digit indication
 % flow rate, actual flow rate, integrated value
 ■■■■■■ Unit indication
 ■ Sub display, setting indication screen
 Displayed for 2 seconds



SELF CHECK MODE



Main display 7-segment, 8-digit blinks
 The line mark (—) moves from left to right.
 Sub display: SELF CHECK MODE
 Displayed for 5 seconds



MEASURING MODE

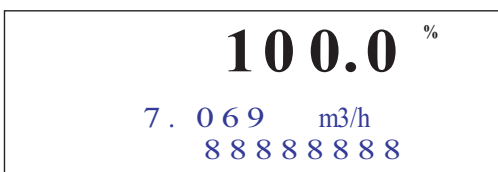

5-1-1 : Display and operation contents of data setting device

Overview of mode

This system provides the following four modes available in accordance with the operations:

Mode	Description
MEASURING MODE	Mode that shows measuring status.
OPERATOR'S MODE	<p>Mode that is set for the operator. This mode is comprised of setting and configuration of data that are set or changed frequently during startup. [Damping constant, auto zero adjustment, counter reset, counter preset value, etc.]</p> <div data-bbox="794 698 1449 1043" style="border: 1px solid black; padding: 5px;"> <p style="text-align: center;">⚠ CAUTION</p> <p>Set or changed data are temporarily written into the memory. Note that if the configured data are not saved/written into the memory within 10 minutes, the configured data returns to the previous values. Be sure to press the MODE key to return to the MEASURING MODE and to save data.</p> </div>
ENGINEERING MODE	<p>In the set mode for engineering, the mode is comprised of data that is set or changed less frequently than the data in "OPERATOR'S MODE." [ID, function selection, detector data, flow rate range, hysteresis width, pulse data, low flow cut, selecting false mode for output, etc.]</p> <div data-bbox="794 1323 1449 1861" style="border: 1px solid black; padding: 5px;"> <p style="text-align: center;">⚠ CAUTION</p> <ul style="list-style-type: none"> • When the mode is changed to MEASURING MODE by pressing the MODE key, the set/changed data are saved into a non-volatile memory. Be sure to press the MODE key to save the configured data. • Set or changed data are temporarily written into the memory. Note that if the configured data are not saved/written into the memory within 10 minutes, the configured data returns to the previous values. Be sure to press the MODE key to return to the MEASURING MODE and to save data. </div>

Mode	Description
<p>MAINTENANCE MODE</p>	<p>A mode for maintenance that is used when adjustments and checks are needed for regular maintenance and when troubles occur. [Loop check, output adjustment, gain adjustment, etc.] This mode is furthermore divided into the following three types: OUTPUT CHECK MODE CALIBRATION MODE CRITICAL MODE</p> <div data-bbox="703 562 1355 866" style="border: 1px solid black; padding: 5px;"> <p style="text-align: center;">⚠ CAUTION</p> <ul style="list-style-type: none"> • CALIBRATION MODE and CRITICAL MODE contains very important adjustment values or operations for the flow rate measurement. Wrong settings make accurate flow rate measurement impossible. For the operation, contact our service engineers. </div> <div data-bbox="703 907 1355 1440" style="border: 1px solid black; padding: 5px;"> <p style="text-align: center;">⚠ CAUTION</p> <ul style="list-style-type: none"> • When the mode is changed to MEASURING MODE by pressing the MODE key, the set/changed data are saved into a non-volatile memory. Be sure to press the MODE key to save the configured data. • Set or changed data are temporarily written into the memory. Note that if the configured data are not saved/written into the memory within 10 minutes, the configured data returns to the previous values. Be sure to press the MODE key to return to the MEASURING MODE and to save data. </div>

5-2 : Functions of the data setting device

5-2-1 : Data setting device

Name of parts

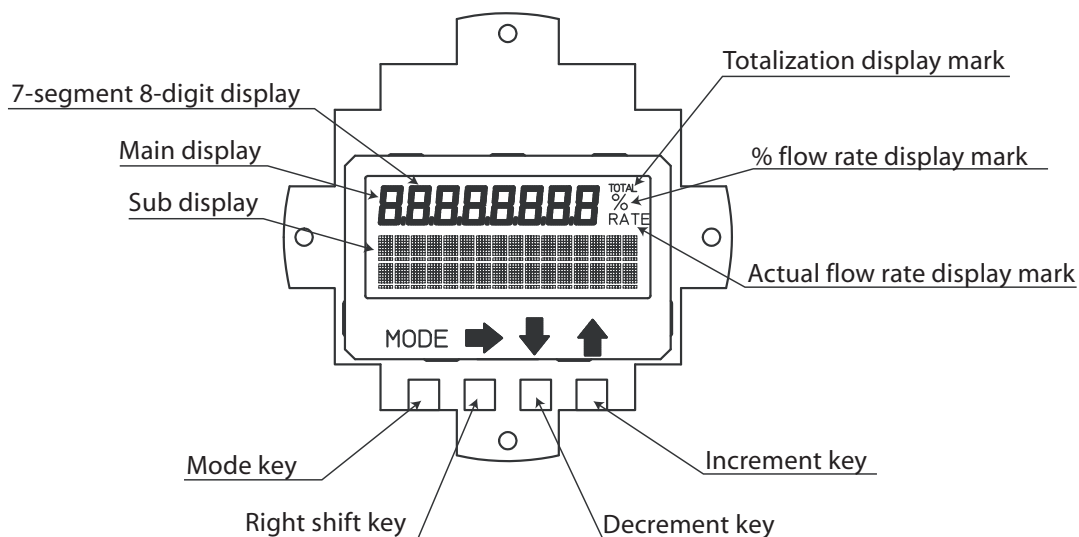

Names and Descriptions of Parts

This section describes displays shown on the data setting device.

- Flow rate display

The flow rate display is given at three stages: % flow rate, actual flow rate and totalized value. Operating the key, the main display to be shown at the top stage can be set selecting from the actual flow rate, % flow rate and totalized value. RATE appears for the actual flow rate display, % for the % flow rate display, and TOTAL for the totalized value display (see “5-3-1 : Display overview”).

Area	Description
Main display 7-segment 8-digit display	Displays the flow rate display selected for the main display by DISP SELECT in OPERATOR'S MODE.
% flow rate display mark (%)	Displays when % flow rate is shown for the main display.
Actual flow rate display mark (RATE)	Displays when the actual flow rate is shown for the main display.
Totalized value display mark (TOTAL)	Displays when the totalized value is shown for the main display.
Sub display	<ul style="list-style-type: none"> In MEASURING MODE, shows a flow rate display other than a flow rate display selected for the main display by DISP SELECT in OPERATOR'S MODE. In modes other than MEASURING MODE, indicate procedures for setting and adjusting parameters.

This section describes keys on the data setting device.

Name	Description
MODE key	<ul style="list-style-type: none"> Enters OPERATOR'S MODE. When parameters and configured data have been changed in ENGINEERING MODE or MAINTENANCE MODE, press this key to save the data.
Right shift key	<ul style="list-style-type: none"> Moves the cursor to the right.
Decrement key	<ul style="list-style-type: none"> Changes the parameter at a cursor position. Displays the previous screen. <div style="display: flex; justify-content: space-between;"> <div data-bbox="657 667 1007 792"> <p>* OPERATOR'S MODE Cursor points to *</p> </div> <div data-bbox="1023 640 1372 786"> <p>If the key is pressed, when the cursor is placed at the upper left end (*, #, >), the screen will change.</p> </div> </div> <div style="display: flex; justify-content: space-between; margin-top: 10px;"> <div data-bbox="657 853 1007 978"> <p>* DAMPING 001.0 S Cursor points to 001.0</p> </div> <div data-bbox="1023 826 1372 972"> <p>If the key is pressed, when the cursor is placed at a number, the number is decremented.</p> </div> </div> <div style="display: flex; justify-content: space-between; margin-top: 10px;"> <div data-bbox="657 1039 1007 1164"> <p># 1.0000 m/s SPAN 07.069 m³/h Cursor points to .</p> </div> <div data-bbox="1023 1012 1372 1122"> <p>If the cursor is placed at a decimal point, the decimal point moves rightward.</p> </div> </div>
Increment key	<ul style="list-style-type: none"> Changes the parameter at a cursor position. Displays the following screen. <div style="display: flex; justify-content: space-between;"> <div data-bbox="657 1323 1007 1449"> <p>* OPERATOR'S MODE Cursor points to *</p> </div> <div data-bbox="1023 1296 1372 1442"> <p>If the key is pressed, when the cursor is placed at the upper left end (*, #, >), the screen will change.</p> </div> </div> <div style="display: flex; justify-content: space-between; margin-top: 10px;"> <div data-bbox="657 1509 1007 1635"> <p>* DAMPING 001.0 S Cursor points to 001.0</p> </div> <div data-bbox="1023 1482 1372 1628"> <p>If the key is pressed, when the cursor is placed at a number, the number is incremented.</p> </div> </div> <div style="display: flex; justify-content: space-between; margin-top: 10px;"> <div data-bbox="657 1695 1007 1821"> <p># 1.0000 m/s SPAN 07.069 m³/h Cursor points to .</p> </div> <div data-bbox="1023 1668 1372 1814"> <p>If the key is pressed, when the cursor is placed at a decimal point, the decimal point moves to the left.</p> </div> </div> <div style="display: flex; justify-content: space-between; margin-top: 10px;"> <div data-bbox="657 1881 1007 2007"> <p>* AUTO ZERO READY Cursor points to *</p> </div> <div data-bbox="1023 1854 1372 1964"> <p>If the cursor is placed over READY, pressing the key starts operation.</p> </div> </div>

5-3 : Description of MEASURING MODE

5-3-1 : Display overview

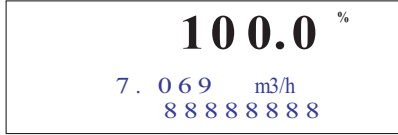
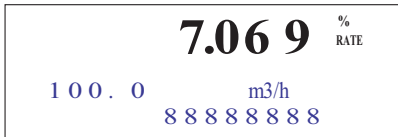
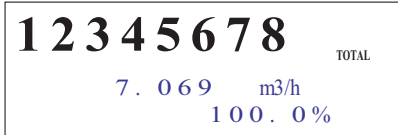
<p>% flow rate display</p> 	<p>1st line (Main display): 7-segment 4-digit display % flow rate (%)</p> <p>2nd line: Actual flow rate display (Significant value of 5 digits)</p> <p>3rd line: Totalized value display (Significant figure of 8 digits)</p>
<p>Actual flow rate display</p> 	<p>1st line (Main display): 7-segment 4-digit display Actual flow rate (RATE)</p> <p>2nd line: % flow rate display (Significant figure of 4 digits), unit of actual flow rate</p> <p>3rd line: Totalized value display (Significant figure of 8 digits)</p>
<p>Totalizer display</p> 	<p>1st line (Main display): 7-segment 8-digit display Totalized value (TOTAL)</p> <p>2nd line: Actual flow rate display (Significant figure of 4 digits)</p> <p>3rd line: % flow rate display (Significant figure of 4 digits)</p>

Totalization is not performed, when the output selection is set to the contact output. However, the previous value is displayed as the totalized value.

* Details on display

% flow rate display: The % flow rate display range is from -115.0% to 115.0%.

A value up to the first decimal place is displayed. The position of the decimal point is fixed.

The integer part to be displayed has up to three digits (0 to 115).

In the main display, unnecessary zeros are deleted (but are not deleted in the sub display).

Example) 019.8% → 19.8%

-000.5% → -0.5%

The position of the negative sign (-) is fixed. (The positive sign is not displayed.)

Actual flow rate display: The flow rate displayed in the actual flow rate display is up to 115% of the range or the equivalent.

However, if the flow rate equivalent to 115% of the range exceeds the range of significant figure, the highest value (e.g., 9.999) will be displayed.

In the main display, unnecessary zeros are deleted (but are not deleted in the sub display).

Totalized value display: An totalized value is displayed in 8 digits without signs and decimal points.

In the main display, unnecessary zeros are deleted (but are not deleted in the sub display).

Next to 99999999, totalization starts from 00000000.

5-4 : Overview of operation using the data setting device

Introduction

The data setting device has three types of modes: OPERATOR'S MODE, ENGINEERING MODE, and MAINTENANCE MODE. MAINTENANCE MODE is furthermore divided into three of sub-modes: OUTPUT, CALIBRATION, and CRITICAL. The screen flow is as follows:

Entire display flow 1

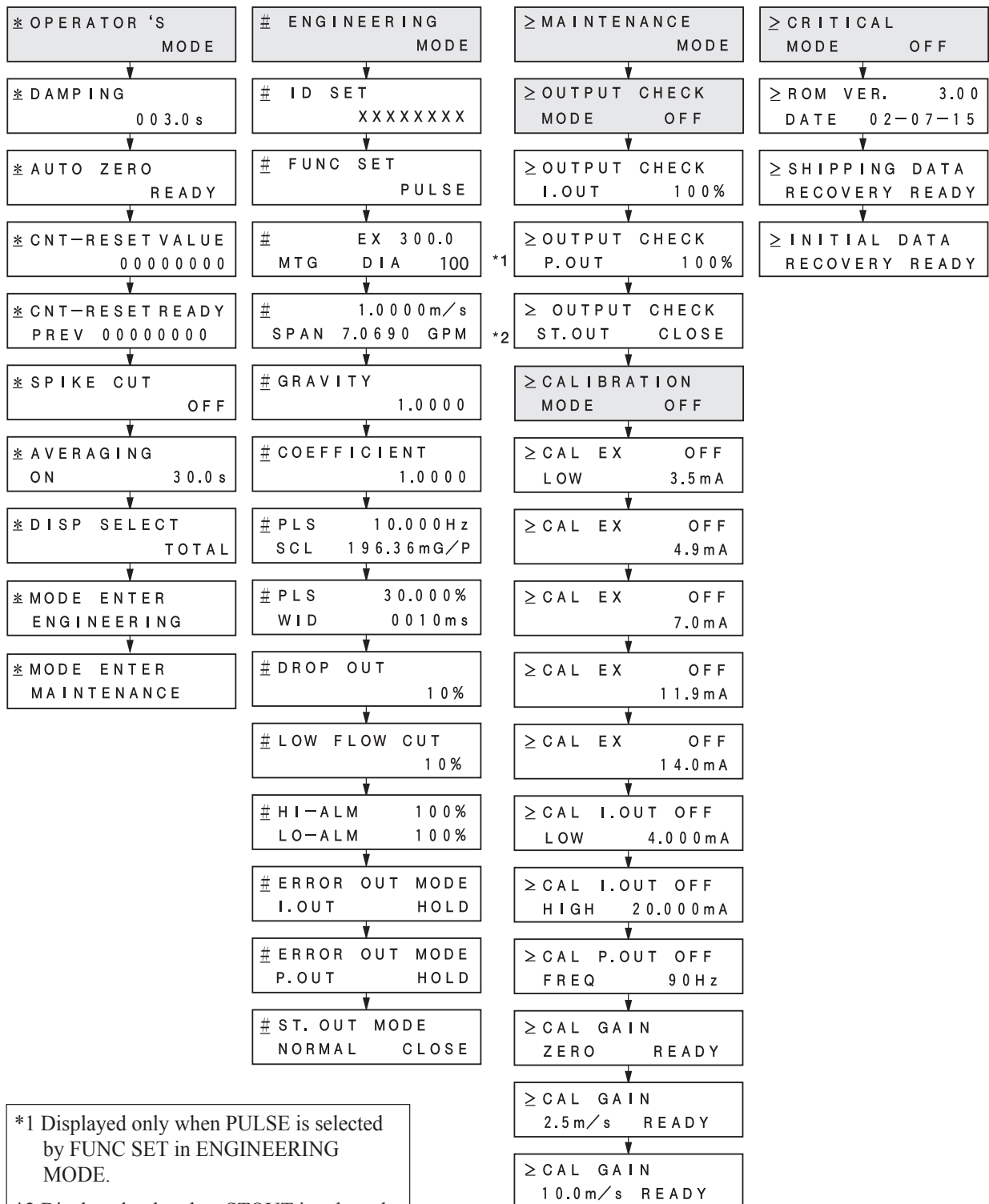

*1 Displayed only when PULSE is selected by FUNC SET in ENGINEERING MODE.
*2 Displayed only when STOUT is selected by FUNC SET in ENGINEERING MODE.

5-5 : Configuration of OPERATOR'S MODE

Introduction

OPERATOR'S MODE provides the following setting and adjustment items.
 For details on functions in the items, see “5-5-1 : Changing setting of damping time constant” and later.

Item	Contents	Screen
DAMPING	Sets a damping time constant.	<div style="border: 1px solid black; padding: 5px; width: fit-content;"> <div style="text-align: right;">20.0 %</div> *_ DAMPING <div style="text-align: right;">005.0 s</div> </div>
AUTO ZERO	Auto zero adjustment	<div style="border: 1px solid black; padding: 5px; width: fit-content;"> <div style="text-align: right;">20.0 %</div> *_ AUTO ZERO <div style="text-align: right;">READY</div> </div>
CNT-RESET VALUE	Sets a built-in counter reset value.	<div style="border: 1px solid black; padding: 5px; width: fit-content;"> <div style="text-align: right;">20.0 %</div> *_ CNT-RESET VALUE <div style="text-align: right;">0 0 0 4 4 4 4</div> </div>
CNT-RESET READY	Resets totalized value to a built-in counter reset value.	<div style="border: 1px solid black; padding: 5px; width: fit-content;"> <div style="text-align: right;">20.0 %</div> *_ CNT-RESET READY <div style="text-align: right;">0 0 0 0 0 0 0 0</div> </div>
SPIKE CUT	Sets auto spike cut.	<div style="border: 1px solid black; padding: 5px; width: fit-content;"> <div style="text-align: right;">20.0 %</div> *_ SPIKE CUT <div style="text-align: right;">OFF</div> </div>
AVERAGING	Sets a moving average function.	<div style="border: 1px solid black; padding: 5px; width: fit-content;"> <div style="text-align: right;">20.0 %</div> *_ AVERAGING <div style="text-align: right;">OFF</div> </div>
DISP SELECT	Selects either % flow rate, actual flow rate or totalized value to be displayed in the main display.	<div style="border: 1px solid black; padding: 5px; width: fit-content;"> <div style="text-align: right;">20.0 %</div> *_ DISP SELECT <div style="text-align: right;">%</div> </div>
MODE ENTER ENGINEERING	Enters the ENGINEERING MODE.	<div style="border: 1px solid black; padding: 5px; width: fit-content;"> <div style="text-align: right;">20.0 %</div> *_ MODE ENTER ENGINEERING </div>
MODE ENTER MAINTENANCE	Enters the MAINTENANCE MODE.	<div style="border: 1px solid black; padding: 5px; width: fit-content;"> <div style="text-align: right;">20.0 %</div> *_ MODE ENTER MAINTENANCE </div>

LCD display flow

The LCD display flow of the OPERATOR'S MODE is as shown below:

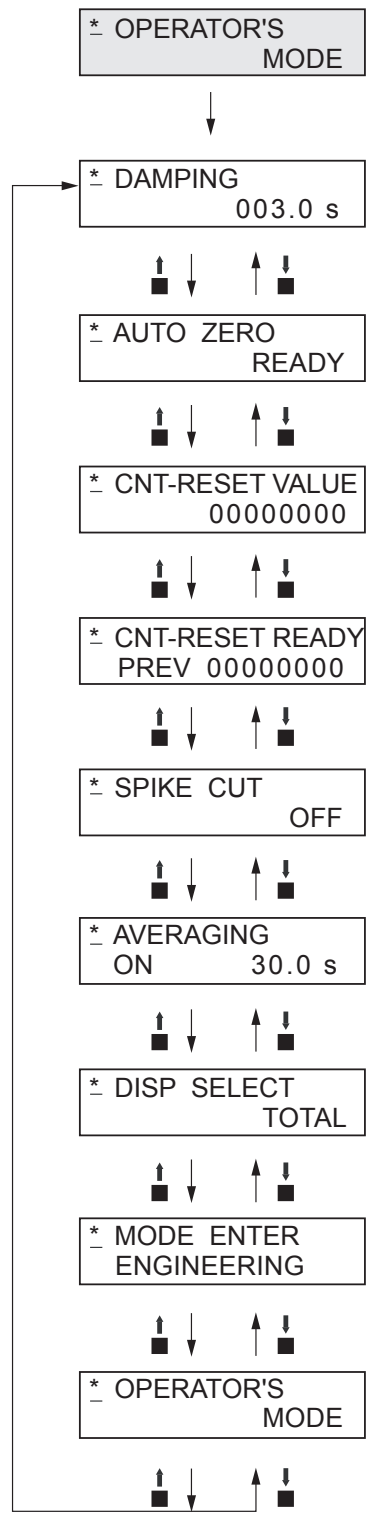

5-5-1 : Changing setting of damping time constant

Damping means a response time of the primary time lag (63.2% response) for a step response of the flow rate. If the out fluctuations are large, increase the damping. A large damping value stabilizes the output but lowers the response performance. We suggest setting the damping to the largest value the system can accept.

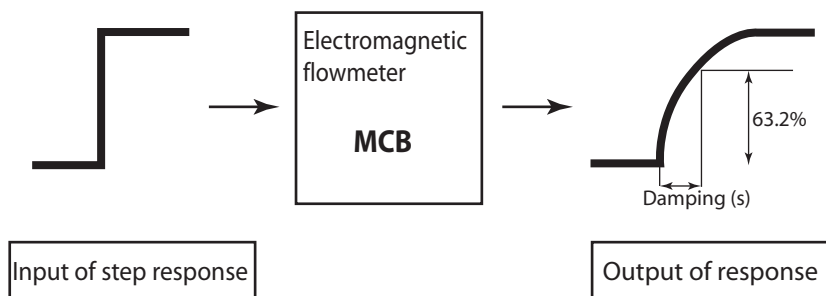

Figure 5-1 Damping output characteristics

Set the damping time constant in accordance with the following procedure:

Step	Procedure	Screen
1	The screen at right is a screen display example in MEASURING MODE (measurement state). Press the MODE key.	<div style="border: 1px solid black; padding: 5px; text-align: right;"> 20.0 % 01.94 m³/h 00069401 </div>
2	The OPERATOR'S MODE screen appears for approx. two seconds and then the damping setting screen appears.	<div style="border: 1px solid black; padding: 5px; text-align: right;"> 20.0 % * _ OPERATOR'S MODE </div> <div style="border: 1px solid black; padding: 5px; text-align: right; margin-top: 5px;"> 20.0 % * _ DAMPING 005.0 s </div>
3	Press the → key until the cursor is at the value to be changed. In this example, the key is pressed three times to move to the position "5."	<div style="border: 1px solid black; padding: 5px; text-align: right;"> 20.0 % * DAMPING 00<u>5</u>.0 s </div>
4	Press the ↑ or ↓ key to display a time constant to be changed. In this example, the ↑ key is pressed five times to change the damping time from 5 seconds to 10 seconds.	<div style="border: 1px solid black; padding: 5px; text-align: right;"> 20.0 % * DAMPING 00<u>5</u>.0 s </div>
5	Press the → key until the cursor is back at the mode indicator. Press the MODE key to return to the MEASURING MODE and to save data.	<div style="border: 1px solid black; padding: 5px; text-align: right;"> 20.0 % * _ DAMPING 010.0 s </div>

⚠ CAUTION

You have only ten minutes to return to MEASURING MODE to save the new value before the system resets it to the previously saved value.

5-5-2 : Auto zero adjustment

Auto zero must be carried out only under the condition when the detector is filled with process fluid at zero flow. Run this function only after installing the electromagnetic flowmeter to the process pipe. Performing this function under a condition where the process fluid is not at zero flow may cause measurement errors.

Set range: None in particular

Default: None in particular

Make the auto zero adjustment in accordance with the following procedure:

Step	Procedure	Screen
1	The screen at right is a screen display example in MEASURING MODE (measurement state). Press the MODE key.	<div style="border: 1px solid black; padding: 5px; text-align: center;"> 1.0 % 01.94 m³/h 00069401 </div>
2	The OPERATOR'S MODE screen appears for approx. two seconds and then the damping setting screen appears.	<div style="border: 1px solid black; padding: 5px; text-align: center;"> 1.0 % * OPERATOR'S _ MODE </div> <div style="border: 1px solid black; padding: 5px; text-align: center;"> 1.0 % * DAMPING _ 005.0 s </div>
3	Press the ↑ key once to display the screen as shown.	<div style="border: 1px solid black; padding: 5px; text-align: center;"> 1.0 % * AUTO ZERO _ READY </div>
4	Press the → key to move the cursor to the position READY.	<div style="border: 1px solid black; padding: 5px; text-align: center;"> 1.0 % * AUTO ZERO _ <u>READY</u> </div>
5	Press the ↑ key to start the auto zero adjustment. If the main display selects % flowrate, the display of 0.0 blinks during adjustment. With the adjustment completed, the display stops blinking with ON switched to READY. This zero adjustment takes about one minute.	<div style="border: 1px solid black; padding: 5px; text-align: center;"> 0.0 % * AUTO ZERO _ <u>ON</u> </div> <div style="border: 1px solid black; padding: 5px; text-align: center;"> 1.0 % * AUTO ZERO _ <u>READY</u> </div>
6	Press the → key to move the cursor to the position under *. Press the MODE key to return to the MEASURING MODE and save data.	<div style="border: 1px solid black; padding: 5px; text-align: center;"> 1.0 % * <u>AUTO ZERO</u> _ READY </div>

⚠ CAUTION

You have only ten minutes to return to MEASURING MODE to save the new value before the system resets it to the previously saved value.

5-5-3 : Setting built-in counter reset value

Set a start value of the built-in counter. The scale of this value is considered as the weight of the pulse. Carry out the built-in counter reset in “5-5-4 : Resetting built-in counter totalized value” to start totalization from any totalized value.

Set range: 00000000 - 99999999

Default: 00000000

Set an internal counter reset value in accordance with the following procedure:

Step	Procedure	Screen
1	The screen at the right is a screen display example in MEASURING MODE (measurement state). Press the MODE key.	<div style="border: 1px solid black; padding: 5px; text-align: right;"> 20.0 % 01.94 m³/h 00069401 </div>
2	The OPERATOR'S MODE screen appears for approx. two seconds and then the damping setting screen appears.	<div style="border: 1px solid black; padding: 5px; text-align: right;"> 20.0 % * OPERATOR'S MODE </div> <div style="border: 1px solid black; padding: 5px; text-align: right; margin-top: 5px;"> 20.0 % * DAMPING 005.0 s </div>
3	Press the ↑ key twice to display the screen.	<div style="border: 1px solid black; padding: 5px; text-align: right;"> 20.0 % * CNT-RESET VALUE 00044444 </div>
4	Press the → key to move the cursor to the position under a target value to be changed.	<div style="border: 1px solid black; padding: 5px; text-align: right;"> 20.0 % * CNT-RESET VALUE 0000<u>0</u>000 </div>
5	Press the ↑ or ↓ key to set a desired value.	<div style="border: 1px solid black; padding: 5px; text-align: right;"> 20.0 % * CNT-RESET VALUE 0000<u>5</u>000 </div>
6	Press the → key to move the cursor to the position under *. Press the MDOE key to return to the MEASURING MODE and to save data.	<div style="border: 1px solid black; padding: 5px; text-align: right;"> 20.0 % * CNT-RESET VALUE 00005000 </div>

⚠ CAUTION

You have only ten minutes to return to MEASURING MODE to save the new value before the system resets it to the previously saved value.

5-5-4 : Resetting built-in counter totalized value

Reset the built-in counter to start totalization from a value set as the built-in counter reset value. If this value is set to 1000, the built-in counter starts totalization from 1000 after the counter is completely reset.

If the built-in counter is reset, the built-in counter value just before the reset appears at the side of PREV on the LCD display.

Set range: None

Default: None

Reset the internal counter in accordance with the following procedure:

Step	Procedure	Screen
1	The screen at the right is a screen display example in MEASURING MODE (measurement state). Press the MODE key.	<div style="border: 1px solid black; padding: 5px; text-align: right;"> 20.0 % 01.94 m³/h 00069401 </div>
2	The OPERATOR'S MODE screen appears for approx. two seconds and then the damping setting screen appears.	<div style="border: 1px solid black; padding: 5px; text-align: right;"> 20.0 % * _ OPERATOR'S MODE </div> <div style="border: 1px solid black; padding: 5px; text-align: right; margin-top: 10px;"> 20.0 % * _ DAMPING 005.0 s </div>
3	Press the ↑ key three times to display the screen shown on the right.	<div style="border: 1px solid black; padding: 5px; text-align: right;"> 20.0 % * _ CNT-RESET READY PREV 00000000 </div>
4	Press the → key to move the cursor to the position READY.	<div style="border: 1px solid black; padding: 5px; text-align: right;"> 20.0 % * CNT-RESET <u>READY</u> PREV 00000000 </div>
5	Press the ↑ key to reset. In 0.5 seconds, the reset is completed with ON changing to READY.	<div style="border: 1px solid black; padding: 5px; text-align: right;"> 20.0 % * CNT-RESET <u>ON</u> PREV 00000000 </div> <div style="border: 1px solid black; padding: 5px; text-align: right; margin-top: 10px;"> 20.0 % * CNT-RESET READY PREV 00123456 </div>
6	Press the → key to move the cursor to the position under *. Press the MODE key to return to the MEASURING MODE and save data.	<div style="border: 1px solid black; padding: 5px; text-align: right;"> 20.0 % * _ CNT-RESET READY PREV 00123456 </div>

⚠ CAUTION

You have only ten minutes to return to MEASURING MODE to save the new value before the system resets it to the previously saved value.

5-5-5 : Setting auto spike cut

This function eliminates steep noise spikes (spike noise) in the flow rate. Noise generated when foreign matters collide with electrode is an example of the spike noise.

When the flow rate changes sharply, this function holds the outputs according to the damping time. Generally the spike noise occurs in a few milliseconds and settles down within the output holding time and the outputs are not affected. For ordinary flowrate changes, the output responds after the damping hold time.

It is not recommended to use this function for applications requiring high response and performance, e.g., the function should not be used when a pump frequently generates pulsation.

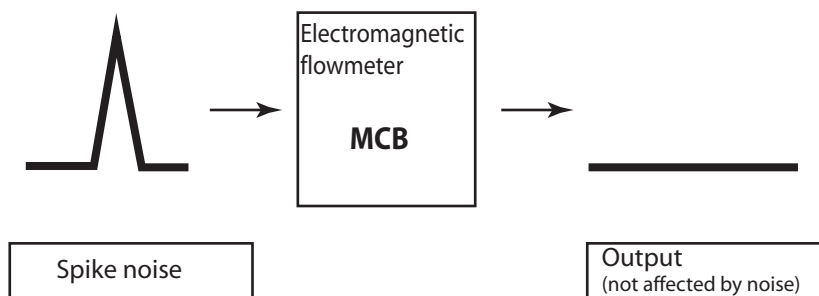

Figure 5-2 Auto spike cut output characteristics

Set the auto spike cut in accordance with the following procedure.

Step	Procedure	Screen
1	The screen at right is a screen display example in MEASURING MODE (measurement state). Press the MODE key.	<div style="border: 1px solid black; padding: 5px; text-align: right;"> 20.0 % 01.94 m³/h 00069401 </div>
2	The OPERATOR'S MODE screen appears for approx. two seconds and then the damping setting screen appears.	<div style="border: 1px solid black; padding: 5px; text-align: right;"> 20.0 % * OPERATOR'S _ MODE </div> <div style="border: 1px solid black; padding: 5px; text-align: right; margin-top: 10px;"> 20.0 % * DAMPING _ 005.0 s </div>
3	Press the ↑ key four times to display the screen shown on the right.	<div style="border: 1px solid black; padding: 5px; text-align: right;"> 20.0 % * SPIKE CUT _ OFF </div>
4	Press the → key to move the cursor to the OFF position.	<div style="border: 1px solid black; padding: 5px; text-align: right;"> 20.0 % * SPIKE CUT _ OFF </div>

Step	Procedure	Screen
5	Press the ↑ or ↓ key to select ON or OFF.	
6	Press the → key to move the cursor to the position under *. Press the MODE key to return to the MEASURING MODE and save data.	

⚠ CAUTION

You have only ten minutes to return to MEASURING MODE to save the new value before the system resets it to the previously saved value.

5-5-6 : Setting moving average processing

This function is used to carry out the moving average processing of the measured flow rate values. The model MCB performs the flow rate calculation every 400 ms. For example, if the moving average process time is set to 2 seconds, the moving average processing will be carried out $2 \text{ sec.}/400 \text{ ms} = 5$ times.

If pulsation are generated, this function can be used to suppress the flow rate fluctuations.

The moving average processing can be given by the following formula:

$$Q_{current} = \frac{\sum_{n=1}^k Q_k}{k}$$

Example) When the moving average processing is set to 2 sec.:

$$Q_{current} = \frac{q_k + Q_{k-1} + Q_{k-2} + Q_{k-3} + Q_{k-4}}{5}$$

where q_k is a value currently measured, and Q_k is a previous output value.

Set range: ON / OFF
ON (1.0 to 30.0 s)

Default: OFF

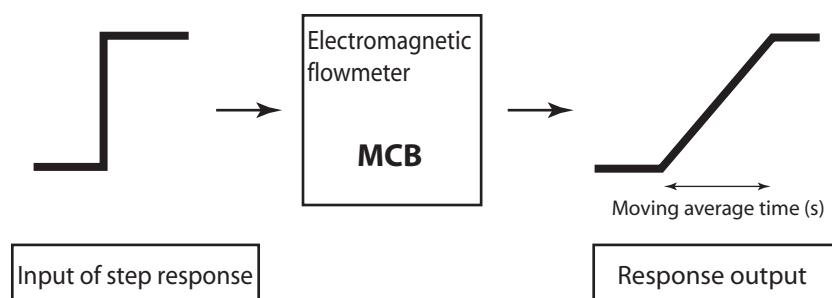

Figure 5-3 Output characteristics of moving average processing

Set the moving average processing in accordance with the following procedure:

Step	Procedure	Screen
1	The screen at right is a screen display example in MEASURING MODE (measurement state). Press the MODE key.	<div style="border: 1px solid black; padding: 5px; text-align: right;"> 20.0 % 01.94 m³/h 00069401 </div>
2	The OPERATOR'S MODE screen appears for approx. two seconds and then the damping setting screen appears.	<div style="border: 1px solid black; padding: 5px; text-align: right;"> 20.0 % * OPERATOR'S _ MODE </div> <div style="border: 1px solid black; padding: 5px; text-align: right; margin-top: 10px;"> 20.0 % * DAMPING _ 005.0 s </div>
3	Press the ↑ or ↓ key to display the screen shown on the right.	<div style="border: 1px solid black; padding: 5px; text-align: right;"> 20.0 % * AVERAGING _ OFF </div>
4	Press the → key to move the cursor to the OFF position.	<div style="border: 1px solid black; padding: 5px; text-align: right;"> 20.0 % * AVERAGING _ OFF </div>
5	Press the ↑ key to switch the OFF screen to the ON screen. Press the → key to move the cursor to the value to be changed.	<div style="border: 1px solid black; padding: 5px; text-align: right;"> 20.0 % * AVERAGING ON 01.0 s </div>
6	Press the ↑ or ↓ key to display a value to be set.	<div style="border: 1px solid black; padding: 5px; text-align: right;"> 20.0 % * AVERAGING ON 05.0 s </div>
7	Press the → key to move the cursor back to the position under *. Press the MODE key to return to the MEASURING MODE and save data.	<div style="border: 1px solid black; padding: 5px; text-align: right;"> 20.0 % * AVERAGING _ ON 05.0 s </div>

⚠ CAUTION

You have only ten minutes to return to MEASURING MODE to save the new value before the system resets it to the previously saved value.

5-5-7 : Selecting flow rate to be displayed in the main display

Select the flow rate to be always shown in the main display. The flow rates other than that selected for the main display are shown in the sub displays. Thereby, three flow rates can always be monitored.

Set	Description
%	% flow rate
RATE	Actual flow rate
TOTAL	Totalized value

% (% flow rate): Displays % flow rate

RATE (Actual flow rate)

Setting range: %, RATE, TOTAL

Default: RATE

Select the flow rate to be shown in the main display in accordance with the following procedure:

Step	Procedure	Screen
1	The screen at right is a screen display example in MEASURING MODE (measurement state). Press the MODE key.	<div style="border: 1px solid black; padding: 5px; text-align: right;"> 20.0 % 01.94 m³/h 00069401 </div>
2	The OPERATOR'S MODE screen appears for approx. two seconds and then the damping setting screen appears.	<div style="border: 1px solid black; padding: 5px; text-align: right;"> 20.0 % * OPERATOR'S MODE </div> <div style="border: 1px solid black; padding: 5px; text-align: right; margin-top: 5px;"> 20.0 % * DAMPING 005.0 s </div>
3	Press the ↑ or ↓ key to display the screen as shown on the right.	<div style="border: 1px solid black; padding: 5px; text-align: right;"> 20.0 % * DISP SELECT % </div>
4	Press the → key to move the cursor to the position for the flow rate display method (% , RATE, TOTAL). The screen at right shows an example where % flow rate has been set for the main display.	<div style="border: 1px solid black; padding: 5px; text-align: right;"> 20.0 % * OPERATOR'S MODE </div>
5	Press the ↑ or ↓ key to select a flow rate display to be set. The screen at right shows an example where RATE (actual flow rate) display has been selected.	<div style="border: 1px solid black; padding: 5px; text-align: right;"> 0.30 RATE * DISP SELECT RATE </div>
6	Press the → key to move the cursor to the position under *. Press the MODE key to return to the MEASURING MODE and to change to the set flow rate display.	<div style="border: 1px solid black; padding: 5px; text-align: right;"> 0.30 RATE * DISP SELECT RATE </div>

⚠ CAUTION

You have only ten minutes to return to MEASURING MODE to save the new value before the system resets it to the previously saved value.

5-5-8 : Entering ENGINEERING MODE and MAINTENANCE MODE

Introduction

This section describes how to enter ENGINEERING MODE, in which setup parameters for the electromagnetic flowmeter are to be configured, and MAINTENANCE MODE, in which calibration and check are to be carried out.

The procedure for entering ENGINEERING MODE is shown below.

Step	Procedure	Screen
1	The screen shown right is a screen display example in MEASURING MODE (measurement state). Press the MODE key.	<div style="border: 1px solid black; padding: 5px; text-align: right;"> 20.0 % 01.94 m³/h 00069401 </div>
2	The OPERATOR'S MODE screen appears for approx. two seconds and then the damping setting screen appears.	<div style="border: 1px solid black; padding: 5px; text-align: right;"> 20.0 % * OPERATOR'S _ MODE </div> <div style="border: 1px solid black; padding: 5px; text-align: right; margin-top: 5px;"> 20.0 % * DAMPING _ 005.0 s </div>
3	Press the ↑ key twice to display the screen as shown.	<div style="border: 1px solid black; padding: 5px; text-align: right;"> 20.0 % * MODE ENTER _ ENGINEERING </div>
4	Press the → key once to move the cursor to the position shown on the screen.	<div style="border: 1px solid black; padding: 5px; text-align: right;"> 20.0 % * MODE ENTER _ ENGINEERING </div>
5	Press the ↑ key. With the display is changed, ENGINEERING MODE is active. The screen appears in approx. two seconds.	<div style="border: 1px solid black; padding: 5px; text-align: right;"> 20.0 % # ENGINEERING _ MODE </div> <div style="border: 1px solid black; padding: 5px; text-align: right; margin-top: 5px;"> 20.0 % # ID SET _ XXXXXXXX </div>

The procedure for entering MAINTENANCE MODE is shown below.

Step	Procedure	Screen
1	The screen shown on the right is a screen display example in MEASURING MODE (measurement state). Press the MODE key.	<div style="border: 1px solid black; padding: 5px; text-align: right;"> 20.0 % 01.94 m³/h 00069401 </div>
2	The OPERATOR'S MODE screen appears for approx. two seconds and then the damping setting screen appears.	<div style="border: 1px solid black; padding: 5px; text-align: right;"> 20.0 % * OPERATOR'S _ MODE </div> <div style="border: 1px solid black; padding: 5px; text-align: right;"> 20.0 % * DAMPING _ 005.0 s </div>
3	Press the ↑ key once to display the screen as shown on the right.	<div style="border: 1px solid black; padding: 5px; text-align: right;"> 20.0 % * MODE ENTER _ MAINTENANCE </div>
4	Press the → key once to move the cursor to the position shown on the screen.	<div style="border: 1px solid black; padding: 5px; text-align: right;"> 20.0 % * MODE ENTER _ MAINTENANCE </div>
5	Press the ↑ key. With the display changed, MAINTENANCE MODE is active. The screen appears in approx. two seconds.	<div style="border: 1px solid black; padding: 5px; text-align: right;"> 20.0 % ≥ MAINTENANCE _ MODE </div> <div style="border: 1px solid black; padding: 5px; text-align: right;"> 20.0 % ≥ OUTPUT CHECK _ MODE OFF </div>

5-6 : Configuration of ENGINEERING MODE

Introduction

ENGINEERING MODE has the following setting and adjustment items:

For details on items, see “5-6-1 : Setting ID” to “5-6-14 : Setting contact output status”.

Item	Contents	Screen
ID SET	Sets ID and TAG No.	<div style="border: 1px solid black; padding: 5px; width: fit-content;"> <div style="text-align: right;">20.0 %</div> # ID SET XXXXXXXXXX </div>
FUNC SET	Setting of open collector output, selects pulse output or contact output.	<div style="border: 1px solid black; padding: 5px; width: fit-content;"> <div style="text-align: right;">20.0 %</div> # FUNC SET PULSE </div>
EX, DIA	Sets the detector information (Ex value and bore diameter).	<div style="border: 1px solid black; padding: 5px; width: fit-content;"> <div style="text-align: right;">20.0 %</div> # EX 300.0 MCB DIA 200 </div>
SPAN	Sets the flow rate range.	<div style="border: 1px solid black; padding: 5px; width: fit-content;"> <div style="text-align: right;">20.0 %</div> # 1.0000 m/s SPAN 7.0690 m³/h </div>
GRAVITY	Sets the specific gravity when mass flow rate unit is selected.	<div style="border: 1px solid black; padding: 5px; width: fit-content;"> <div style="text-align: right;">20.0 %</div> # GRAVITY 1.0000 </div>
COEFFICIENT	Sets a compensation coefficient for flow rate calculation.	<div style="border: 1px solid black; padding: 5px; width: fit-content;"> <div style="text-align: right;">20.0 %</div> # COEFFICIENT 1.0000 </div>
PLS SCL	Sets flow rate (pulse scale) per pulse.	<div style="border: 1px solid black; padding: 5px; width: fit-content;"> <div style="text-align: right;">20.0 %</div> # PLS 10.000 Hz SCL 200.00 I/P </div>
PLS WID	Sets the output pulse width.	<div style="border: 1px solid black; padding: 5px; width: fit-content;"> <div style="text-align: right;">20.0 %</div> # PLS 10.000 Hz WID 0010 ms </div>

Item	Contents	Screen
DROP OUT	Sets drop out.	<div style="border: 1px solid black; padding: 5px; width: fit-content;"> <div style="text-align: right;">20.0 %</div> # DROPOUT <div style="text-align: right;">10 %</div> </div>
LOW FLOW CUT	Sets low flow cut.	<div style="border: 1px solid black; padding: 5px; width: fit-content;"> <div style="text-align: right;">20.0 %</div> # LOW FLOW CUT <div style="text-align: right;">10 %</div> </div>
HI-ALM/LOW-ALM	Sets upper/lower limit alarm.	<div style="border: 1px solid black; padding: 5px; width: fit-content;"> <div style="text-align: right;">20.0 %</div> # HI-AIM 100 % LO-AIM 0 % </div>
ERROR OUT MODE I. OUT	Determines the analog output failsafe direction.	<div style="border: 1px solid black; padding: 5px; width: fit-content;"> <div style="text-align: right;">20.0 %</div> # ERROR OUT MODE I.OUT HOLD </div>
ERROR OUT MODE P. OUT	Determines the pulse output failsafe direction.	<div style="border: 1px solid black; padding: 5px; width: fit-content;"> <div style="text-align: right;">20.0 %</div> # ERROR OUT MODE P.OUT HOLD </div>
ST. OUT MODE	Sets a contact output status.	<div style="border: 1px solid black; padding: 5px; width: fit-content;"> <div style="text-align: right;">20.0 %</div> # ST. OUTMODE NORMAL CLOSE </div>

~Note *After the MODE key is pressed, configured data in the ENGINEERING MODE are saved in non-volatile memory. When configure data, be sure to press the MODE key to save the data.*

LCD display flow

The ENGINEERING MODE display flow is as follows:

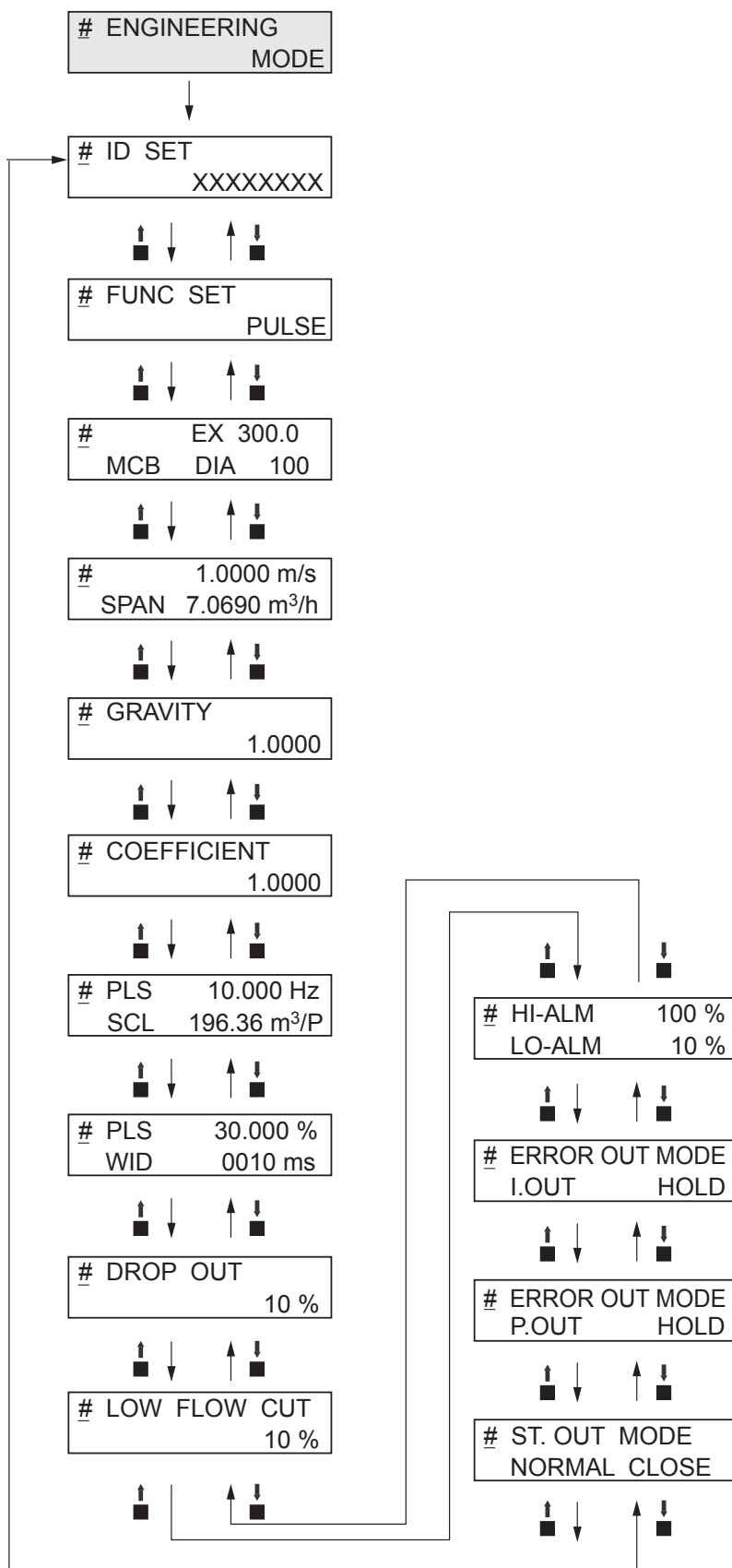

5-6-1 : Setting ID

You can enter a unique 8-digit alphanumeric code for the flowmeter.

Up to eight alphanumeric characters using any combination of letters (A to Z), numbers (0 to 9), - (dash), / (slash), space and period.

Set an ID in accordance with the following procedure:

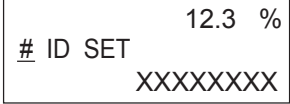
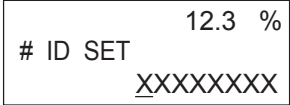
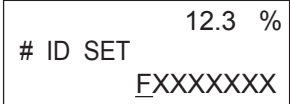
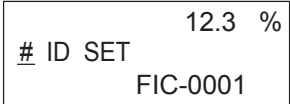
Step	Procedure	Screen
1	Enter ENGINEERING MODE (see section 5-4-10) and display the screen where the ID is to be set.	 <pre> 12.3 % # ID SET XXXXXXXXXX </pre>
2	Press the → key to move the cursor to the position under a desired character to be changed.	 <pre> 12.3 % # ID SET _XXXXXXXXXX </pre>
3	Press the ↑ or ↓ key to select a desired character.	 <pre> 12.3 % # ID SET _FXXXXXXXXX </pre>
4	If a target TAG NO. has been set, press the → key to move the cursor to the position under #. Press the MODE key to return to MEASURING MODE and to save data.	 <pre> 12.3 % # ID SET FIC-0001 </pre>

5-6-2 : Selecting pulse output or contact output

Pulse output or contact output are selectable. Both of them are open collector outputs.

When pulse output has been selected:

Set pulse scale, pulse width, drop out, and burn out.

When contact output has been selected:

As a contact output, self diagnosis output (critical failure) or upper/lower limit alarm is output.

Select % flow rate value for upper/lower alarm or output status (OPEN or CLOSE in normal (normal state)).

Setting range: PULSE: Selection of pulse output

STOUT: Selection of contact output

Default: PULSE

Select pulse output or contact output in accordance with the following procedure:

Step	Procedure	Screen
1	Enter ENGINEERING MODE in accordance with the entry into ENGINEERING MODE (see section 5-4-10). Then press the ↑ or ↓ key to display the screen at right.	<div style="border: 1px solid black; padding: 5px; width: fit-content;"> <div style="display: flex; justify-content: space-between;"> # FUNCSET 20.0 % </div> <div style="text-align: right; margin-top: 5px;">PULSE</div> </div>
2	Press the → key to move the cursor to the position for set function. Press the ↑ or ↓ key to display a function to be set. Select either PULSE (pulse output) or STOUT (contact output).	<div style="border: 1px solid black; padding: 5px; width: fit-content;"> <div style="display: flex; justify-content: space-between;"> # FUNCSET 20.0 % </div> <div style="text-align: right; margin-top: 5px;"><u>P</u>LSE</div> </div> <div style="border: 1px solid black; padding: 5px; width: fit-content;"> <div style="display: flex; justify-content: space-between;"> # FUNCSET 20.0 % </div> <div style="text-align: right; margin-top: 5px;"><u>S</u>TOUT</div> </div>
3	Press the MODE key to return to the MEASURING MODE and to save data.	<div style="border: 1px solid black; padding: 5px; width: fit-content;"> <div style="display: flex; justify-content: space-between;"> # FUNCSET 20.0 % </div> <div style="text-align: right; margin-top: 5px;">STOUT</div> </div>

⚠ CAUTION

You have only ten minutes to return to MEASURING MODE to save the new value before the system resets it to the previously saved value.

5-6-3 : Setting detector information

Set detector information necessary for combination with the converter.

- EX value: Each detector has a unique calibration factor (EX value).
This value is determined at shipment in accordance with the actual flow rate calibration. DO NOT change this value or the flowmeter output will be incorrect.
- Detector type: Detector type is set as MCB.
- Bore diameter: Sets the bore diameter (inside diameter) of the detector. The correct bore diameter is set as factory default setting.
- Setting range: Detector constant: 200.0 to 699.9
Detector type: MCB
Bore diameter: 15 to 100

Set the detector information in accordance with the following procedure:

Step	Procedure	Screen									
1	Enter ENGINEERING MODE in accordance with the entry into ENGINEERING MODE (see section 5-4-10). Then press the ↑ or ↓ key to display the screen at right.	<table border="1"> <tr> <td></td> <td></td> <td>12.3 %</td> </tr> <tr> <td>#</td> <td>EX</td> <td>300.0</td> </tr> <tr> <td>MCB</td> <td>DIA</td> <td>050.0</td> </tr> </table>			12.3 %	#	EX	300.0	MCB	DIA	050.0
		12.3 %									
#	EX	300.0									
MCB	DIA	050.0									
2	Press the → key to set the detector constant. Using the ↑ or ↓ key, enter the numeric value found in the EX column stamped on the nameplate of the detector to be combined.	<table border="1"> <tr> <td></td> <td></td> <td>12.3 %</td> </tr> <tr> <td>#</td> <td>EX</td> <td>320.0</td> </tr> <tr> <td>MCB</td> <td>DIA</td> <td>050.0</td> </tr> </table>			12.3 %	#	EX	320.0	MCB	DIA	050.0
		12.3 %									
#	EX	320.0									
MCB	DIA	050.0									
3	Verify the detector type is MCB.	<table border="1"> <tr> <td></td> <td></td> <td>12.3 %</td> </tr> <tr> <td>#</td> <td>EX</td> <td>320.0</td> </tr> <tr> <td><u>MCB</u></td> <td>DIA</td> <td>050.0</td> </tr> </table>			12.3 %	#	EX	320.0	<u>MCB</u>	DIA	050.0
		12.3 %									
#	EX	320.0									
<u>MCB</u>	DIA	050.0									
4	Then press the → key to select the bore diameter. Verify the bore diameter matches with the diameter on the name plate.	<table border="1"> <tr> <td></td> <td></td> <td>12.3 %</td> </tr> <tr> <td>#</td> <td>EX</td> <td>320.0</td> </tr> <tr> <td>MCB</td> <td>DIA</td> <td>100.<u>0</u></td> </tr> </table>			12.3 %	#	EX	320.0	MCB	DIA	100. <u>0</u>
		12.3 %									
#	EX	320.0									
MCB	DIA	100. <u>0</u>									
5	Using the → key, move the cursor to the position under #. Press the MODE key to return to the MEASURING MODE and save data.	<table border="1"> <tr> <td></td> <td></td> <td>12.3 %</td> </tr> <tr> <td><u>#</u></td> <td>EX</td> <td>320.0</td> </tr> <tr> <td>MCB</td> <td>DIA</td> <td>100.0</td> </tr> </table>			12.3 %	<u>#</u>	EX	320.0	MCB	DIA	100.0
		12.3 %									
<u>#</u>	EX	320.0									
MCB	DIA	100.0									

CAUTION

You have only ten minutes to return to MEASURING MODE to save the new value before the system resets it to the previously saved value.

5-6-4 : Setting flow rate range

Set the flow rate range. The lower limit of the range is ZERO. The upper limit, which is the value when the output reaches 100%, is entered here along with the selection of engineering and time units. The range has an upper limit value of 5 m/s in flow velocity when it is calculated at the upper stage of the display. It has a lower limit value of 1 m/s.

Set the flow rate range so that the regular flow rate is greater than or equal to 50% of the flow rate range.

Pressing the MODE key automatically deletes unnecessary zeros, if any, from the flow rate range.

Example: 07.069 → 7.0690 (Unnecessary zero is deleted.)

Setting range:

Flow rate range: 0 to 0.0001, 0 to 99999.

Units of flow rate:

Unit of SI volume flow rate: m³, l, cm³

Unit of SI mass flow rate: t, kg, g

Unit of non-SI volume flow rate: mG, G, kG, B, mIG, IG, kIG

Unit of SI mass flow rate: lb

Unit of time: d, h, min., s

Set the flow rate range in accordance with the following procedure:

Step	Procedure	Screen
1	Enter ENGINEERING MODE in accordance with the entry into ENGINEERING MODE (see section 5-4-10). Then press the ↑ or ↓ key to display the screen at right.	<div style="border: 1px solid black; padding: 5px; width: fit-content;"> <div style="text-align: right;">12.3 %</div> <div># 1.4147 m/s</div> <div>SPAN 10.000 m³/h</div> </div>
2	Press the → key to move the cursor to a desired digit to be set.	<div style="border: 1px solid black; padding: 5px; width: fit-content;"> <div style="text-align: right;">12.3 %</div> <div># 1.4147 m/s</div> <div>SPAN <u>1</u>0.000 m³/h</div> </div>
3	Using the ↑ or ↓ key, change the value to a desired one.	<div style="border: 1px solid black; padding: 5px; width: fit-content;"> <div style="text-align: right;">12.3 %</div> <div># 1.4147 m/s</div> <div>SPAN 20.000 m³/<u>h</u></div> </div>
4	In addition, press the → key to move the cursor to the position under a desired flow rate unit. Using the ↑ or ↓ key, select the unit.	<div style="border: 1px solid black; padding: 5px; width: fit-content;"> <div style="text-align: right;">12.3 %</div> <div># 1.4147 m/s</div> <div>SPAN 20.000 <u>l</u>/h</div> </div>
5	Then press the → key to move the cursor to the position under the time unit. Using the ↑ or ↓ key, select the unit.	<div style="border: 1px solid black; padding: 5px; width: fit-content;"> <div style="text-align: right;">12.3 %</div> <div># 1.4147 m/s</div> <div>SPAN 333.33/<u>min</u></div> </div>
6	Press the → key to move the cursor to the position under #. Press MODE key to return to the MEASURING MODE, and to save data.	<div style="border: 1px solid black; padding: 5px; width: fit-content;"> <div style="text-align: right;">12.3 %</div> <div># 1.4147 m/s</div> <div>SPAN 333.33/<u>min</u></div> </div>

⚠ CAUTION

You have only ten minutes to return to MEASURING MODE to save the new value before the system resets it to the previously saved value.

5-6-5 : Setting and changing compensation coefficient

This function is used to set or change the compensation coefficient which is used to multiply the output flow rate as required.

Set range: 0.10000 to 5.9999

Default: 1.0000

Set and change a compensation coefficient in accordance with the following procedure:

Step	Procedure	Screen
1	Enter ENGINEERING MODE in accordance with the entry into ENGINEERING MODE (see section 5-4-10). Then press the ↑ or ↓ key to display the screen at right.	<div style="border: 1px solid black; padding: 5px; text-align: right;"> 12.3 % # COEFFICIENT 1.0000 </div>
2	Press the → key to move the cursor to the position under a desired value to be set or changed.	<div style="border: 1px solid black; padding: 5px; text-align: right;"> 12.3 % # COEFFICIENT 1.00<u>0</u> </div>
3	Using the ↑ or ↓ key, change the value to the desired one to be set.	<div style="border: 1px solid black; padding: 5px; text-align: right;"> 12.3 % # COEFFICIENT 1.00<u>5</u>0 </div>
4	Press the → key to move the cursor to the position under #. Press the MODE key to return to the MEASURING MDOE and to save data.	<div style="border: 1px solid black; padding: 5px; text-align: right;"> 12.3 % # COEFFICIENT 1.0050 </div>

⚠ CAUTION

You have only ten minutes to return to MEASURING MODE to save the new value before the system resets it to the previously saved value.

5-6-6 : Setting specific gravity

This function is used to set the specific gravity when selecting a weight unit (t, kg, g, lb) in the flow rate range setting.

Set range: 0.1000 to 5.9999

Default: 1.0000

Set the specific gravity in accordance with the following procedure:

Step	Procedure	Screen
1	Enter ENGINEERING MODE in accordance with the entry into ENGINEERING MODE (see section 5-4-10). Then press the ↑ or ↓ key to display the screen at right.	<div style="border: 1px solid black; padding: 5px; width: fit-content;"> <div style="display: flex; justify-content: space-between;"> # GRAVITY 12.3 % </div> <div style="text-align: right; margin-top: 5px;">1.0000</div> </div>
2	Press the → key to move the cursor to the position under a desired value to be set or changed.	<div style="border: 1px solid black; padding: 5px; width: fit-content;"> <div style="display: flex; justify-content: space-between;"> # GRAVITY 12.3 % </div> <div style="text-align: right; margin-top: 5px;">1.00<u>0</u>0</div> </div>
3	Using the ↑ or ↓ key, change the value to the desired one to be set.	<div style="border: 1px solid black; padding: 5px; width: fit-content;"> <div style="display: flex; justify-content: space-between;"> # GRAVITY 12.3 % </div> <div style="text-align: right; margin-top: 5px;">1.00<u>5</u>0</div> </div>
4	Press the → key to move the cursor to the position under #. Press the MODE key to return to the MEASURING MODE and to save data.	<div style="border: 1px solid black; padding: 5px; width: fit-content;"> <div style="display: flex; justify-content: space-between;"> # GRAVITY 12.3 % </div> <div style="text-align: right; margin-top: 5px;">1.0050</div> </div>

⚠ CAUTION

You have only ten minutes to return to MEASURING MODE to save the new value before the system resets it to the previously saved value.

5-6-7 : Setting pulse scale

This function is used to set the flow rate per pulse and associated units for a flowmeter. Pulse scale of the totalization value indicated on the display is equal to the pulse scale set here.

Set range: 0.0001 to 99999.

However, the pulse scale should be set so that the pulse output span frequency f_s (shown in the auxiliary display) is between 0.0001 Hz and 500 Hz.

$$0.0001 \text{ Hz} \leq f_s \leq 500 \text{ Hz}$$

Units of flow rate:

Unit of SI volume flow rate: $\text{m}^3, \text{l}, \text{cm}^3$

Unit of SI mass flow rate: $\text{t}, \text{kg}, \text{g}$

Unit of non-SI volume flow rate: $\text{mG}, \text{G}, \text{kG}, \text{B}, \text{mlG}, \text{IG}, \text{kIG}$

Unit of SI mass flow rate: lb

Unit of time: $\text{d}, \text{h}, \text{min.}, \text{s}$

Default: $10.000 \text{ m}^3/\text{P}$

~Note *Select the same unit systems (volume unit or mass unit) for the flow rate range and pulse scale. Selection of different unit systems for them will cause set errors (Err-22 PULSE WEIGHT SETTING ERROR). (See "5-8-2 : Non-critical error" on page 5-54.)*

Calculation method of span frequency:

Span frequency f_s can be calculated by the following formula:

$$f_s = (\text{Flow rate range}) / (\text{Pulse scale})$$

To calculate f_s , pay attention to the following points:

- * Convert flow range into the range per second.
- * Select the same unit of flow rate for flow rate range and pulse scale.

Example) When flow rate range: 60 l/min. , and pulse scale: $10 \text{ cm}^3/\text{P}$:

1. Convert the flow rate range into the flow rate range per second.
 $60 \text{ l/min.} \rightarrow 60/60 \text{ l/s}$
 $= 1 \text{ l/s}$
2. Select the same unit of flow rate for flow rate range and pulse scale.
 In this example, the unit of pulse scale is changed.
 $10 \text{ cm}^3/\text{P} \rightarrow 10/1000 \text{ l/P}$
 $= 0.01 \text{ l/P}$
3. Calculate the span frequency.
 $(1 \text{ l/P}) / (0.01 \text{ l/P})$
 $= 100 \text{ Hz}$
 $f_s = 100 \text{ Hz}$

Set pulse scale in accordance with the following procedure:

Step	Procedure	Screen						
1	Enter ENGINEERING MODE in accordance with the entry into ENGINEERING MODE (see section 5-4-10). Then press the ↑ or ↓ key to display the screen at right.	<div style="border: 1px solid black; padding: 5px; width: fit-content;"> <table style="width: 100%; border-collapse: collapse;"> <tr> <td style="width: 60%;"></td> <td style="text-align: right;">12.3 %</td> </tr> <tr> <td># PLS</td> <td style="text-align: right;">27.780 Hz</td> </tr> <tr> <td>SCL</td> <td style="text-align: right;">100.00 l/p</td> </tr> </table> </div>		12.3 %	# PLS	27.780 Hz	SCL	100.00 l/p
	12.3 %							
# PLS	27.780 Hz							
SCL	100.00 l/p							
2	Press the → key to move the cursor to the position under a desired value to be set or changed.	<div style="border: 1px solid black; padding: 5px; width: fit-content;"> <table style="width: 100%; border-collapse: collapse;"> <tr> <td style="width: 60%;"></td> <td style="text-align: right;">12.3 %</td> </tr> <tr> <td># PLS</td> <td style="text-align: right;">27.780 Hz</td> </tr> <tr> <td>SCL</td> <td style="text-align: right;"><u>100.00</u> l/p</td> </tr> </table> </div>		12.3 %	# PLS	27.780 Hz	SCL	<u>100.00</u> l/p
	12.3 %							
# PLS	27.780 Hz							
SCL	<u>100.00</u> l/p							
3	Using the ↑ or ↓ key, change the value to a desired pulse scale to be set.	<div style="border: 1px solid black; padding: 5px; width: fit-content;"> <table style="width: 100%; border-collapse: collapse;"> <tr> <td style="width: 60%;"></td> <td style="text-align: right;">12.3 %</td> </tr> <tr> <td># PLS</td> <td style="text-align: right;">13.890 Hz</td> </tr> <tr> <td>SCL</td> <td style="text-align: right;"><u>200.00</u> l/p</td> </tr> </table> </div>		12.3 %	# PLS	13.890 Hz	SCL	<u>200.00</u> l/p
	12.3 %							
# PLS	13.890 Hz							
SCL	<u>200.00</u> l/p							
4	Press the → key to move the cursor to the position under #. Press the MODE key to return to the MEASURING MDOE and to save data.	<div style="border: 1px solid black; padding: 5px; width: fit-content;"> <table style="width: 100%; border-collapse: collapse;"> <tr> <td style="width: 60%;"></td> <td style="text-align: right;">12.3 %</td> </tr> <tr> <td># PLS</td> <td style="text-align: right;">13.890 Hz</td> </tr> <tr> <td>SCL</td> <td style="text-align: right;">200.00 l/p</td> </tr> </table> </div>		12.3 %	# PLS	13.890 Hz	SCL	200.00 l/p
	12.3 %							
# PLS	13.890 Hz							
SCL	200.00 l/p							

⚠ CAUTION

You have only ten minutes to return to MEASURING MODE to save the new value before the system resets it to the previously saved value.

5-6-8 : Setting pulse width

Set a pulse width. The pulse width should be set in accordance with the specifications of the pulse receiver installed.

Set range

DUTY 50%

Pulse width that is DUTY 50% of the span frequency, and 1,000 ms (1s) maximum. The pulse duty ratio defines the pulse ON time versus the pulse OFF time as a percentage of the total pulse cycle.

NUM (setting of a real value)

0001 to 1,000 ms (1 s)

* With DUTY 50%, no setting error appears.

* With NUM (with a real value set), a setting error occurs if the pulse width exceeds the DUTY ratio of 70% in span frequency.

Default:

DUTY 50%

Method of setting pulse width:

The DUTY ratio is B/A (%) in the diagram at right.

1. NUM (when real pulse width is selected)

DUTY ratio < 70%

Set the pulse width as shown above.

Calculation method: When the range is 360 m^3 , and pulse scale is 2 l/P,

First convert the unit of range to calculate the span frequency.

Convert the range into the unit of per-second (/s).

$$360 \text{ m}^3/\text{s} \rightarrow 0.1 \text{ m}^3/\text{s}$$

Convert the unit of flow rate range to be same as the unit of pulse scale.

$$0.1 \text{ m}^3/\text{s} \rightarrow 0.1 * 1000 \text{ l/s} \\ 100 \text{ l/s}$$

Calculation of span frequency

$$(100 \text{ l/s}) / (2 \text{ l/P})$$

$$= 50 \text{ Hz}$$

$$50 \text{ Hz} \rightarrow 20 \text{ ms (= A)}$$

Calculation of pulse width where the DUTY ratio is equivalent to 70%

$$B = 0.7 \times A$$

$$= 0.7 \times 20 \text{ ms}$$

$$= 14 \text{ ms}$$

Therefore, set the pulse width to less than 14 ms.

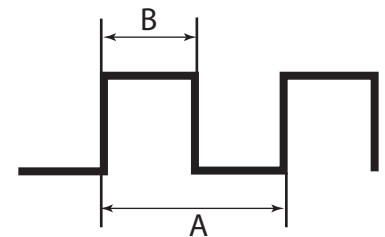

2. DUTY 50% (Automatically set)

Selecting DUTY 50% automatically sets the pulse width as follows:

Calculation method 1

Make calculations to obtain a pulse width that is DUTY 50% of the span frequency. The pulse width is automatically set. In this case, the calculated value of the pulse width does not appear on the display.

Calculation method 2

In addition, if the pulse width calculated by the calculation method 1 exceeds 1 second, the pulse width is set to 1 second.

Calculation method 1: When the range is 360 m³/h, and pulse scale is 2 l/P,

First convert the unit of range to calculate the span frequency.

Convert the range into the unit of per-second (/s).

$$360 \text{ m}^3/\text{h} \rightarrow 0.1 \text{ m}^3/\text{s}$$

Convert the unit of flow rate range to be same as the unit of pulse scale.

$$0.1 \text{ m}^3/\text{s} \rightarrow 0.1 \times 1000 \text{ l/s} \\ 100 \text{ l/s}$$

Calculation of span frequency

$$(100 \text{ l/s}) / (2 \text{ l/P})$$

$$= 50 \text{ Hz}$$

$$50 \text{ Hz} \rightarrow 20 \text{ ms} (= A)$$

Calculation of pulse width where the DUTY ratio is equivalent to 50%

$$B = 0.5 \times A \\ = 0.5 \times 20 \text{ ms} \\ = 10 \text{ ms}$$

Therefore, the pulse width is 10 ms.

Calculation method 2: When the range is 36 m³/h, and pulse scale is 100 l/P,

First convert the unit of range to calculate the span frequency.

Convert the range into the unit of per-second (/s).

$$36 \text{ m}^3/\text{h} \rightarrow 0.01 \text{ m}^3/\text{s}$$

Convert the unit of flow rate range to be same as unit of pulse scale.

$$0.01 \text{ m}^3/\text{s} \rightarrow 0.01 \times 1000 \text{ l/s} \\ 10 \text{ l/s}$$

Calculation of span frequency

$$(10 \text{ l/s}) / (100 \text{ l/p})$$

$$= 0.1 \text{ Hz}$$

$$0.1 \text{ Hz} \rightarrow 10 \text{ s} (= A)$$

Calculation of pulse width where the DUTY ratio is equivalent to 50%

$$B = 0.5 \times A \\ = 0.5 \times 10 \text{ s} \\ = 5 \text{ s}$$

Because the calculated pulse width exceeds 1 s, it takes 1s.

Set a pulse width in accordance with the following procedure:

Step	Procedure	Screen
1	Enter ENGINEERING MODE in accordance with the entry into ENGINEERING MODE (see section 5-4-10). Then press the ↑ or ↓ key to display the screen at right.	<pre> 12.3 % # PLS 27.778 % WID NUM 010.00ms </pre>
2	Press the → key to move the cursor to the position under NUM.	<pre> 12.3 % # PLS 27.778 % WID <u>N</u>UM 010.00ms </pre>
3	Pressing the ↑ key switches a screen for entering a numeric value for pulse width to a screen for fixing the DUTY ratio to 50%.	<pre> 12.3 % # PLS WID <u>D</u>UTY 50 % </pre>
4	To enter a numeric value for pulse width, press the ↑ key to return to the screen for the entry of numeric values. Using the → key, move the cursor to the position under a desired digit to be set.	<pre> 12.3 % # PLS 27.778 % WID NUM 01<u>0</u>.00ms </pre>
5	Using the ↑ or ↓ key, change the value to a desired value to be set.	<pre> 12.3 % # PLS 13.889 % WID NUM 00<u>5</u>.00ms </pre>
6	Press the → key to move the cursor to the position under #. Press the MODE key to return to the MEASURING MODE and to save data.	<pre> 12.3 % # PLS 13.889 % WID NUM 005.00ms </pre>

⚠ CAUTION

You have only ten minutes to return to MEASURING MODE to save the new value before the system resets it to the previously saved value.

5-6-9 : Setting drop out

This function is used to set the drop out value for the pulse output. The pulse output will be cut off at this point to avoid flow pulsation in range values close to zero, thus preventing incorrect totalization of the flow rate.

Pulse counting pauses when the flow rate reaches this preset percentage of the set range.

Setting range: 0 to 10%

Default: 5%

Set drop out in accordance with the following procedure:

Step	Procedure	Screen
1	Enter ENGINEERING MODE in accordance with the entry into ENGINEERING MODE (see section 5-4-10). Then press the ↑ or ↓ key to display the screen at right.	<div style="border: 1px solid black; padding: 5px; width: fit-content;"> <div style="text-align: right;">12.3 %</div> # DROPOUT <div style="text-align: right;">05 %</div> </div>
2	Press the → key.	<div style="border: 1px solid black; padding: 5px; width: fit-content;"> <div style="text-align: right;">12.3 %</div> # DROPOUT <div style="text-align: right;">0<u>5</u> %</div> </div>
3	Using the ↑ or ↓ key, change the value to a desired value to be set.	<div style="border: 1px solid black; padding: 5px; width: fit-content;"> <div style="text-align: right;">12.3 %</div> # DROPOUT <div style="text-align: right;">0<u>6</u> %</div> </div>
4	Press the → key to move the cursor to the position under #. Press the MODE key to return to the MEASUREMENT MODE and to save data.	<div style="border: 1px solid black; padding: 5px; width: fit-content;"> <div style="text-align: right;">12.3 %</div> # DROPOUT <div style="text-align: right;">06 %</div> </div>

 **CAUTION**

You have only ten minutes to return to MEASURING MODE to save the new value before the system resets it to the previously saved value.

5-6-10 : Setting low flow cutoff

This function is used to set the low flow cutoff value. When the flow rate reaches the entered value, the analog output is cut off and latched to 4 mA (display flow rate of 0%) to avoid errors due to flow pulsation in range value close to zero.

Also, for reverse flow rate, the output is latched to 4 mA (display flow rate of 0%)

The lower limit of the low flow cutoff setting is determined by the velocity range.

1. If the velocity range exceeds 3 m/s, the lower limit value is 1%.
2. If the velocity range is 3 m/s or less, the lower limit value will cut the velocity of 0.03 m/s or less flow the rate.

Example: If the velocity range is set as 2 m/s, the lower limit of the low flow cutoff value is 1.5%. ($= 0.03/2 = 0.015 = 1.5\%$)

Setting range: 1 to 10%

Default: 5%

Set low flow cut in accordance with the following procedure:

Step	Procedure	Screen
1	Enter ENGINEERING MODE in accordance with the entry into ENGINEERING MODE (see section 5-4-10). Then press the ↑ or ↓ key to display the screen at right.	<div style="border: 1px solid black; padding: 5px; text-align: right;"> 12.3 % # LOW-FLOW CUT 05 % </div>
2	Press the → key. The cursor then moves to the position of the low flow cut value.	<div style="border: 1px solid black; padding: 5px; text-align: right;"> 12.3 % # LOW-FLOW CUT 0<u>5</u> % </div>
3	Using the ↑ or ↓ key, change the value to a desired value to be set.	<div style="border: 1px solid black; padding: 5px; text-align: right;"> 12.3 % # LOW-FLOW CUT 0<u>6</u> % </div>
4	Press the → key to move the cursor to the position under #. Press the MODE key to return to MEASURING MODE and to save data.	<div style="border: 1px solid black; padding: 5px; text-align: right;"> 12.3 % # LOW-FLOW CUT 06 % </div>

⚠ CAUTION

You have only ten minutes to return to MEASURING MODE to save the new value before the system resets it to the previously saved value.

5-6-11 : Setting upper and lower limit alarm

This function is used to set the upper and lower limit alarm set points when the contact output is selected.

An alarm is output when the flow rate exceeds these preset upper and lower limits.

The alarm output status depends on the “Setting contact output status” described later.

Set range: HI-ALM 0% to +115%
 LO-ALM 0% to +115%

Default: HI-ALM +115%
 LO-ALM 0%

Set the upper/lower limit alarm in accordance with the following procedure:

Step	Procedure	Screen						
1	Enter ENGINEERING MODE in accordance with the entry into ENGINEERING MODE (see section 5-4-10). Then press the ↑ or ↓ key to display the screen at right.	<table border="1"> <tr> <td></td> <td>12.3 %</td> </tr> <tr> <td># HI-ALM</td> <td>+115%</td> </tr> <tr> <td>LO-ALM</td> <td>+000%</td> </tr> </table>		12.3 %	# HI-ALM	+115%	LO-ALM	+000%
	12.3 %							
# HI-ALM	+115%							
LO-ALM	+000%							
2	Using the → key, move the cursor to the position under a digit to be set or changed.	<table border="1"> <tr> <td></td> <td>12.3 %</td> </tr> <tr> <td># HI-ALM</td> <td>+1<u>0</u>0%</td> </tr> <tr> <td>LO-ALM</td> <td>-000%</td> </tr> </table>		12.3 %	# HI-ALM	+1 <u>0</u> 0%	LO-ALM	-000%
	12.3 %							
# HI-ALM	+1 <u>0</u> 0%							
LO-ALM	-000%							
3	Using the ↑ or ↓ key, change the value to the desired value to be set.	<table border="1"> <tr> <td></td> <td>12.3 %</td> </tr> <tr> <td># HI-ALM</td> <td>+0<u>8</u>0%</td> </tr> <tr> <td>LO-ALM</td> <td>-000%</td> </tr> </table>		12.3 %	# HI-ALM	+0 <u>8</u> 0%	LO-ALM	-000%
	12.3 %							
# HI-ALM	+0 <u>8</u> 0%							
LO-ALM	-000%							
4	Press the → key to move the cursor to the position under #. Press MODE key to return to the MEASURING MODE and to save data.	<table border="1"> <tr> <td></td> <td>12.3 %</td> </tr> <tr> <td># HI-ALM</td> <td>+080%</td> </tr> <tr> <td>LO-ALM</td> <td>-000%</td> </tr> </table>		12.3 %	# HI-ALM	+080%	LO-ALM	-000%
	12.3 %							
# HI-ALM	+080%							
LO-ALM	-000%							

However, set as follows: HI-ALM > LO-ALM.

5-6-12 : Selecting failsafe mode for analog outputs

This function is used to determine the analog output direction when the flowmeter detects a critical status condition.

⚠ CAUTION

The failsafe mode is very important for the overall safety of the control process. Choose the failsafe direction carefully, as equipment damage can result from a wrong choice.

Setting range: **LOW** Analog output is driven to low scale value. (TYP 3.7 mA)
HIGH Analog output is driven to high scale value. (TYP 21.8 mA)
HOLD Analog output is held at its last good value.

Default: **LOW**

Set failsafe mode for analog output in accordance with the following procedure:

Step	Procedure	Screen
1	Enter ENGINEERING MODE in accordance with the entry into ENGINEERING MODE (see section 5-4-10). Then press the ↑ or ↓ key to display the screen at right.	<div style="border: 1px solid black; padding: 5px; text-align: right;"> 12.3 % # ERROR OUT MODE I.OUT LOW </div>
2	Press the → key.	<div style="border: 1px solid black; padding: 5px; text-align: right;"> 12.3 % # ERROR OUT MODE I.OUT <u>LOW</u> </div>
3	Using the ↑ or ↓ key, determine the failsafe mode for analog output.	<div style="border: 1px solid black; padding: 5px; text-align: right;"> 12.3 % # ERROR OUT MODE I.OUT <u>HIGH</u> </div>
4	Press the → key to move the cursor to the position under #. Press the MODE key to return to the MEASURING MODE and to save data.	<div style="border: 1px solid black; padding: 5px; text-align: right;"> 12.3 % # ERROR OUT MODE I.OUT HIGH </div>

⚠ CAUTION

You have only ten minutes to return to MEASURING MODE to save the new value before the system resets it to the previously saved value.

5-6-13 : Selecting failsafe mode for pulse output

This function is used to determine the pulse output direction when the flowmeter detects a critical status condition.

⚠ CAUTION
The failsafe mode is very important for the overall safety of the control process. Choose the failsafe direction carefully, as equipment damage can result from a wrong choice.

Set range: OFF Outputs no pulse.
 HOLD Pulse output signal held at its present state
 Default: OFF

Set failsafe mode for pulse output in accordance with the following procedure:

Step	Procedure	Screen
1	Enter ENGINEERING MODE in accordance with the entry into ENGINEERING MODE (see section 5-4-10). Then press the ↑ or ↓ key to display the screen at right.	<div style="text-align: right;">12.3 %</div> <div># ERROR OUT MODE</div> <div>P.OUT OFF</div>
2	Press the → key.	<div style="text-align: right;">12.3 %</div> <div># ERROR OUT MODE</div> <div>P.OUT <u>OFF</u></div>
3	Using the ↑ or ↓ key, determine the failsafe mode for pulse output.	<div style="text-align: right;">12.3 %</div> <div># ERROR OUT MODE</div> <div>P.OUT <u>HOLD</u></div>
4	Press the → key to move the cursor to the position under #. Press the MODE key to return to the MEASURING MODE and to save data.	<div style="text-align: right;">12.3 %</div> <div># ERROR OUT MODE</div> <div>P.OUT HOLD</div>

⚠ CAUTION
You have only ten minutes to return to MEASURING MODE to save the new value before the system resets it to the previously saved value.

5-6-14 : Setting contact output status

This function is used to set contact output status for normal operation.

This function is effective only when contact output has been selected in the function specification.

Set range: CLOSE Sets the open collector output to ON.

OPEN Sets the open collector output to OFF.

Default: OPEN

Set the contact output status in accordance with the following procedure:

Step	Procedure	Screen
1	Enter ENGINEERING MODE in accordance with the entry into ENGINEERING MODE (see section 5-4-10). Then press the ↑ or ↓ key to display the screen at right.	<div style="border: 1px solid black; padding: 5px; text-align: right;"> 12.3 % # ST. OUT MODE NORMAL CLOSE </div>
2	Press the → key.	<div style="border: 1px solid black; padding: 5px; text-align: right;"> 12.3 % # ST. OUT MODE NORMAL <u>C</u>LOSE </div>
3	Using the ↑ key, set the contact output status.	<div style="border: 1px solid black; padding: 5px; text-align: right;"> 12.3 % # ST. OUT MODE NORMAL <u>O</u>PEN </div>
4	Press the → key to move the cursor to the position under #. Press the MODE key to return to the MEASURING MODE and to save data.	<div style="border: 1px solid black; padding: 5px; text-align: right;"> 12.3 % # ST. OUT MODE NORMAL OPEN </div>

⚠ CAUTION

You have only ten minutes to return to MEASURING MODE to save the new value before the system resets it to the previously saved value.

5-6-15 : Selecting failsafe mode for pulse output

This function is used to determine the pulse output direction when the flowmeter detects a critical status condition.

⚠ CAUTION	
<p>The failsafe mode is very important for the overall safety of the control process. Choose the failsafe direction carefully, as equipment damage can result from a wrong choice.</p>	

Set range: OFF Outputs no pulse.
 HOLD Pulse output signal held at its present state.

Default: OFF

Set failsafe mode for pulse output in accordance with the following procedure:

Step	Procedure	Screen
1	Enter ENGINEERING MODE in accordance with the entry into ENGINEERING MODE (see section 5-4-10). Then press the ↑ or ↓ key to display the screen at right.	<div style="text-align: right;">12.3 %</div> <div># ERROR OUT MODE</div> <div>P.OUT OFF</div>
2	Press the → key.	<div style="text-align: right;">12.3 %</div> <div># ERROR OUT MODE</div> <div>P.OUT <u>OFF</u></div>
3	Using the ↑ or ↓ key, determine the failsafe mode for pulse output.	<div style="text-align: right;">12.3 %</div> <div># ERROR OUT MODE</div> <div>P.OUT <u>HOLD</u></div>
4	Press the → key to move the cursor to the position under #. Press the MODE key to return to the MEASURING MODE and to save data.	<div style="text-align: right;">12.3 %</div> <div># ERROR OUT MODE</div> <div>P.OUT HOLD</div>

⚠ CAUTION	
<p>You have only ten minutes to return to MEASURING MODE to save the new value before the system resets it to the previously saved value.</p>	

5-7 : Configuration of MAINTENANCE MODE

Introduction

MAINTENANCE MODE consists of the following three types: OUTPUT CHECK MODE, CALIBRATION MODE, and CRITICAL MODE. For details on the modes, see the following pages.

LCD display flow

The LCD display flow of MAINTENANCE MODE is as follows:

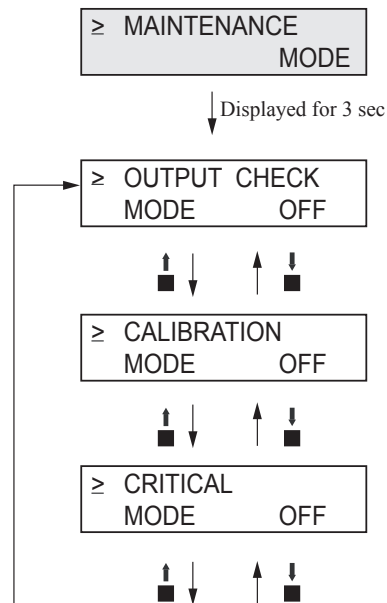

5-7-1 : Configuration of OUTPUT CHECK MODE

Introduction

OUTPUT CHECK MODE has the following setting and adjustment items.

For details on the function of items, see the following pages.

Item	Content	Screen
OUTPUT CHECK I.OUT	Outputs a fixed value of analog current output to perform loop checks.	<div style="border: 1px solid black; padding: 5px; width: fit-content;"> <div style="text-align: right;">12.3 %</div> <div style="text-align: center;">≥ OUTPUT CHECK</div> <div style="text-align: right;">I.OUT 100%</div> </div>
OUTPUT CHECK P.OUT	Outputs a fixed value of pulse output to perform loop checks.	<div style="border: 1px solid black; padding: 5px; width: fit-content;"> <div style="text-align: right;">12.3 %</div> <div style="text-align: center;">≥ OUTPUT CHECK</div> <div style="text-align: right;">P.OUT 100%</div> </div>
OUTPUT CHECK ST.OUT	Outputs a fixed value of contact output to perform loop checks.	<div style="border: 1px solid black; padding: 5px; width: fit-content;"> <div style="text-align: right;">12.3 %</div> <div style="text-align: center;">≥ OUTPUT CHECK</div> <div style="text-align: right;">ST.OUT CLOSE</div> </div>

LCD display flow

The screen flow of OUTPUTCHECK MODE is as follows:

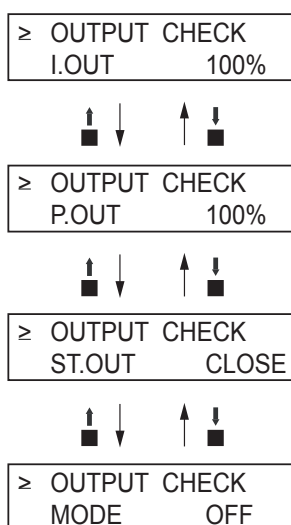

5-7-2 : Performing loop checks of analog outputs

Analog output check

The electromagnetic flowmeter can be used as a constant current generator to check analog outputs. Other instruments in the analog current output loop, such as recorders and controllers can be checked.

Default setting

Displays the current output value.

Setting range

Range settings are allowed ranging from 0 to 100%.

Perform loop checks of analog outputs in accordance with the following procedure:

Step	Procedure	Screen
1	Enter MAINTENANCE MODE in accordance with the entry into MAINTENANCE MODE (see section 5-4-10). Then display the screen at right.	<div style="border: 1px solid black; padding: 5px; width: fit-content;"> <div style="text-align: right;">20.0 %</div> ≥ OUTPUT CHECK MODE OFF </div>
2	Press the → key to move the cursor to the OFF position. Press the ↑ key. With the display switched from OFF to ON, the output check mode is then active.	<div style="border: 1px solid black; padding: 5px; width: fit-content;"> <div style="text-align: right;">20.0 %</div> > OUTPUT CHECK MODE <u>OFF</u> </div> <div style="border: 1px solid black; padding: 5px; width: fit-content;"> <div style="text-align: right;">20.0 %</div> > OUTPUT CHECK MODE <u>ON</u> </div> <div style="border: 1px solid black; padding: 5px; width: fit-content;"> <div style="text-align: right;">20.0 %</div> ≥ OUTPUT CHECK I.OUT 000.0% </div>
3	Press the → key to move the cursor to the position under a desired value to be checked.	<div style="border: 1px solid black; padding: 5px; width: fit-content;"> <div style="text-align: right;">20.0 %</div> > OUTPUT CHECK I.OUT <u>000.0%</u> </div>
4	Pressing the ↑ or ↓ key, change the value to the desired value to be checked. As shown on the screen on the right, the output to the range, given as an analog output, is 100% i.e. 20 mA.	<div style="border: 1px solid black; padding: 5px; width: fit-content;"> <div style="text-align: right;">20.0 %</div> > OUTPUT CHECK I.OUT <u>100.0%</u> </div>
5	Press the → key to move the cursor to the position under >. Movement to another screen by using the ↑ or ↓ key returns to an analog output according to the actual flow rate.	<div style="border: 1px solid black; padding: 5px; width: fit-content;"> <div style="text-align: right;">20.0 %</div> ≥ OUTPUT CHECK I.OUT 100.0% </div>

5-7-3 : Performing loop checks of pulse outputs

Pulse output check

The electromagnetic flowmeter can be used as a pulse generator to check pulse outputs.

This screen appears when pulse output has been selected in FUNC SET of ENGINEERING MODE (see “5-6-2 : Selecting pulse output or contact output”).

Default setting

Displays the current output value.

Setting range

Range settings are allowed ranging from 0 to 100%.

Perform loop checks of pulse outputs in accordance with the following procedure:

Step	Procedure	Screen
1	Enter MAINTENANCE MODE in accordance with the entry into MAINTENANCE MODE (see section 5-4-10). Then display the screen at right.	<div style="border: 1px solid black; padding: 5px; width: fit-content;"> <div style="text-align: right;">20.0 %</div> ≥ OUTPUT CHECK MODE OFF </div>
2	Press the → key to move the cursor to the OFF position. Press the - key. With the display switched from OFF to ON, the output check mode is then active.	<div style="border: 1px solid black; padding: 5px; width: fit-content;"> <div style="text-align: right;">20.0 %</div> > OUTPUT CHECK MODE <u>OFF</u> </div> <div style="border: 1px solid black; padding: 5px; width: fit-content;"> <div style="text-align: right;">20.0 %</div> > OUTPUT CHECK MODE <u>ON</u> </div> <div style="border: 1px solid black; padding: 5px; width: fit-content;"> <div style="text-align: right;">20.0 %</div> ≥ OUTPUT CHECK I.OUT 000.0% </div>
3	Press the ↑ key to display the screen at right.	<div style="border: 1px solid black; padding: 5px; width: fit-content;"> <div style="text-align: right;">20.0 %</div> ≥ OUTPUT CHECK P.OUT 000.0% </div>
4	Press the → key to move the cursor to the position under a desired value to be checked.	<div style="border: 1px solid black; padding: 5px; width: fit-content;"> <div style="text-align: right;">20.0 %</div> > OUTPUT CHECK P.OUT <u>000.0%</u> </div>
5	Pressing the ↑ or ↓ key, change the value to the desired value to be checked. On the screen at right, a frequency pulse corresponding to flow rate signal 100% is output.	<div style="border: 1px solid black; padding: 5px; width: fit-content;"> <div style="text-align: right;">20.0 %</div> > OUTPUT CHECK I.OUT <u>100.0%</u> </div>
6	Press the → key to move the cursor to the position shown on the screen at right. Movement to another screen by using the ↑ or ↓ key returns to a pulse output according to the actual flow rate.	<div style="border: 1px solid black; padding: 5px; width: fit-content;"> <div style="text-align: right;">20.0 %</div> ≥ OUTPUT CHECK I.OUT 100.0% </div>

5-7-4 : Performing loop checks of contact outputs

Contact output check

Contact outputs of electromagnetic flowmeter can be turned on and off to perform loop checks of contact output signals.

This screen appears when contact output has been selected in FUNC SET of ENGINEERING MODE (see “5-6-2 : Selecting pulse output or contact output”).

Default setting

Displays the current contact output status.

Setting range

Set range “CLOSE” and “OPEN”

Perform loop checks of contact outputs in accordance with the following procedure:

Step	Procedure	Screen
1	Enter MAINTENANCE MODE in accordance with the entry into MAINTENANCE MODE (see section 5-4-10). Then display the screen at right.	<div style="border: 1px solid black; padding: 5px; width: fit-content;"> <div style="text-align: right;">20.0 %</div> <div style="text-align: right;">≥ OUTPUT CHECK</div> <div style="text-align: right;">MODE OFF</div> </div>
2	Press the → key to move the cursor to the OFF position. Press the ↑ key. With the display switched from OFF to ON, the output check mode is then active.	<div style="border: 1px solid black; padding: 5px; width: fit-content;"> <div style="text-align: right;">20.0 %</div> <div style="text-align: right;">> OUTPUT CHECK</div> <div style="text-align: right;">MODE OFF</div> </div> <div style="border: 1px solid black; padding: 5px; width: fit-content;"> <div style="text-align: right;">20.0 %</div> <div style="text-align: right;">> OUTPUT CHECK</div> <div style="text-align: right;">MODE ON</div> </div> <div style="border: 1px solid black; padding: 5px; width: fit-content;"> <div style="text-align: right;">20.0 %</div> <div style="text-align: right;">≥ OUTPUT CHECK</div> <div style="text-align: right;">I.OUT 000.0%</div> </div>
3	Press the ↑ key twice to display the screen at right. In this status, a contact output corresponding to the display is output.	<div style="border: 1px solid black; padding: 5px; width: fit-content;"> <div style="text-align: right;">20.0 %</div> <div style="text-align: right;">≥ OUTPUT CHECK</div> <div style="text-align: right;">ST.OUT CLOSE</div> </div>
4	Press the → key to move the cursor to the OPEN or CLOSE position that indicates the status of contact output.	<div style="border: 1px solid black; padding: 5px; width: fit-content;"> <div style="text-align: right;">20.0 %</div> <div style="text-align: right;">> OUTPUT CHECK</div> <div style="text-align: right;">ST.OUT CLOSE</div> </div>
5	Press the → key to move the cursor to the position under >. Movement to another screen by using the ↑ or ↓ key returns the contact output to the output status according to the current status.	<div style="border: 1px solid black; padding: 5px; width: fit-content;"> <div style="text-align: right;">20.0 %</div> <div style="text-align: right;">≥ OUTPUT CHECK</div> <div style="text-align: right;">ST.OUT CLOSE</div> </div>

5-7-5 : Configuration of CALIBRATION MODE

Introduction

CALIBRATION MODE has the following setting and adjustment items:

Configuration of CALIBRATION MODE requires a dedicated calibrator.

Wrong operation may hinder accurate measurements of the flow rate. To operate in this mode, contact an Azbil Corp. representative.

Item	Content	Screen
CAL I.OUT LOW 4.000 mA	Adjusts 4 mA analog current output.	<div style="border: 1px solid black; padding: 5px; width: fit-content;"> <div style="text-align: right;">12.3 %</div> <div style="display: flex; justify-content: space-between;"> ≥ CAL I.OUT OFF </div> <div style="display: flex; justify-content: space-between;"> LOW 4.000 mA </div> </div>
CAL I.OUT HIGH 20.00 mA	Adjusts 20 mA analog current output.	<div style="border: 1px solid black; padding: 5px; width: fit-content;"> <div style="text-align: right;">12.3 %</div> <div style="display: flex; justify-content: space-between;"> ≥ CAL I.OUT OFF </div> <div style="display: flex; justify-content: space-between;"> HIGH 20.000 mA </div> </div>
CAL P.OUT FREQ 90 Hz	Adjusts 90 Hz pulse output.	<div style="border: 1px solid black; padding: 5px; width: fit-content;"> <div style="text-align: right;">12.3 %</div> <div style="display: flex; justify-content: space-between;"> ≥ CAL P.OUT OFF </div> <div style="display: flex; justify-content: space-between;"> FREQ 90 Hz </div> </div>
CAL GAIN ZERO	Adjusts 0 m/s gain.	<div style="border: 1px solid black; padding: 5px; width: fit-content;"> <div style="text-align: right;">12.3 %</div> <div style="display: flex; justify-content: space-between;"> ≥ CAL GAIN OFF </div> <div style="display: flex; justify-content: space-between;"> ZERO READY </div> </div>
CAL GAIN 5 m/s	Adjusts 5 m/s gain.	<div style="border: 1px solid black; padding: 5px; width: fit-content;"> <div style="text-align: right;">12.3 %</div> <div style="display: flex; justify-content: space-between;"> ≥ CAL GAIN OFF </div> <div style="display: flex; justify-content: space-between;"> 5.0 m/s READY </div> </div>

LCD display flow

The LCD display flow of CALIBRATION MODE is as follows:

≥ CAL I. OUT	OFF
LOW	4.000 mA



≥ CAL I. OUT	OFF
HIGH	20.000 mA



≥ CAL P. OUT	OFF
FREQ	90 Hz



≥ CAL GAIN	
ZERO	READY



≥ CAL GAIN	
5.0 m/s	READY



≥ CRITICAL	
MODE	OFF

5-7-6 : Configuration of CRITICAL MODE

Introduction

CRITICAL MODE has the following setting and adjustment items:

Item	Content	Screen
ROM VER DATE	Displays the ROM version and date.	<div style="border: 1px solid black; padding: 5px; width: fit-content;"> <div style="text-align: right;">20.0 %</div> ≥ ROM VER. 000 DATE YY-MM-DD </div>
SHIPPING DATA (default value) RECOVERY	You can return the device to factory setting/default values for pertinent operational and configuration parameters. These parameters are entered before the device is shipped, so they are commonly referred to as “shipping data”. They include factory calibration data and factory settings or initial default settings for customer configuration data.	<div style="border: 1px solid black; padding: 5px; width: fit-content;"> <div style="text-align: right;">20.0 %</div> ≥ SHIPPING DATA RECOVERY READY </div>
INITIAL DATA RECOVERY	Initial data recovery eliminates all calibration data and configuration parameters. DO NOT use this function.	<div style="border: 1px solid black; padding: 5px; width: fit-content;"> <div style="text-align: right;">20.0 %</div> ≥ INITIAL DATA RECOVERY READY </div>

LCD display flow

The screen flow of CRITICAL MODE is as follows:

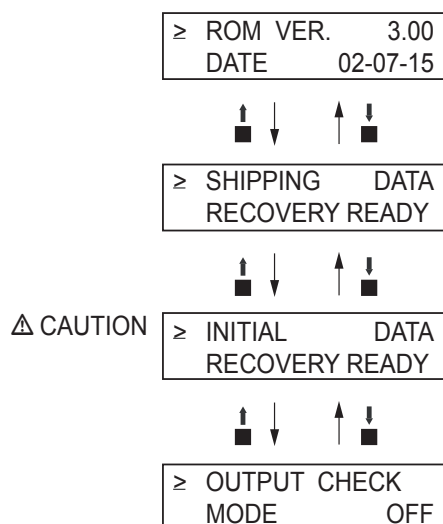

△ CAUTION

INITIAL DATA RECOVERY function is only for Azbil Corporation service/maintenance specialist. Please DO NOT use this function. If this function is turned ON, all calibrated data will be deleted. The device needs to be sent back to the factory to calibrate again.

5-7-7 : Displaying ROM version and date

Displaying ROM version

The ROM version and date of the converter can be displayed on the display screen.

Display the ROM version and data in accordance with the following procedure:

Step	Procedure	Screen
1	Enter MAINTENANCE MODE in accordance with the entry into MAINTENANCE MODE (see section 5-4-10). Using the ↑ or ↓ key, display the screen at right.	<div style="border: 1px solid black; padding: 5px; width: fit-content;"> <div style="text-align: right;">20.0 %</div> ≥ OUTPUT CHECK MODE OFF </div>
2	Press the ↑ key twice to display the screen at right.	<div style="border: 1px solid black; padding: 5px; width: fit-content;"> <div style="text-align: right;">20.0 %</div> ≥ CRITICAL MODE OFF </div>
3	Press the → key to move the cursor to the OFF position. Then press the - key to switch the display from OFF to ON.	<div style="border: 1px solid black; padding: 5px; width: fit-content;"> <div style="text-align: right;">20.0 %</div> > CRITICAL MODE <u>ON</u> </div>
4	After the entry into CRITICAL MODE, the screen at right appears. On the screen, the ROM version and date can be checked.	<div style="border: 1px solid black; padding: 5px; width: fit-content;"> <div style="text-align: right;">20.0 %</div> ≥ ROM VER. DATE YY-MM-DD </div>

5-7-8 : Returning to settings at shipment

SHIPPING DATA (default value) RECOVERY

Performing SHIPPING DATA RECOVERY returns the internal data settings of the device to the settings at time of shipment.

Note that executing this operation erases the data that was set and changed by the customer.

Perform SHIPPING DATA RECOVERY in accordance with the following procedure:

Step	Procedure	Screen
1	Enter MAINTENANCE MODE in accordance with the entry into MAINTENANCE MODE (see section 5-4-10). Using the ↑ or ↓ key, display the screen at right.	<div style="border: 1px solid black; padding: 5px; width: fit-content;"> <div style="text-align: right;">20.0 %</div> ≥ OUTPUT CHECK MODE OFF </div>
2	Press the ↑ key twice to display the screen at right.	<div style="border: 1px solid black; padding: 5px; width: fit-content;"> <div style="text-align: right;">20.0 %</div> ≥ CRITICAL MODE OFF </div>
3	Press the → key to move the cursor to the OFF position. Then press the ↑ key to switch the display from OFF to ON. After the entry into CRITICAL MODE, the screen at right appears.	<div style="border: 1px solid black; padding: 5px; width: fit-content;"> <div style="text-align: right;">20.0 %</div> > CRITICAL MODE <u>ON</u> </div> <div style="border: 1px solid black; padding: 5px; width: fit-content; margin-top: 5px;"> <div style="text-align: right;">20.0 %</div> ≥ ROM VER. [] [] DATE YY-MM-DD </div>
4	Press the ↑ key to display the screen at right.	<div style="border: 1px solid black; padding: 5px; width: fit-content;"> <div style="text-align: right;">20.0 %</div> ≥ SHIPPING DATA RECOVERY READY </div>
5	Press the → key to move the cursor to the READY position, and then keep pressing the ↑ key for three seconds or more.	<div style="border: 1px solid black; padding: 5px; width: fit-content;"> <div style="text-align: right;">20.0 %</div> > SHIPPING DATA RECOVERY <u>READY</u> </div>
6	SHIPPING DATA RECOVER starts. The display will change as shown on the screen at right.	<div style="border: 1px solid black; padding: 5px; width: fit-content;"> <div style="text-align: right;">20.0 %</div> > SHIPPING DATA RECOVERY <u>ON</u> </div> <div style="border: 1px solid black; padding: 5px; width: fit-content; margin-top: 5px;"> <div style="text-align: right;">8.8.8.8.8.8.8.8 <small>% RATE TOTAL</small></div> <div style="background-color: blue; height: 10px; width: 100%;"></div> </div> <div style="border: 1px solid black; padding: 5px; width: fit-content; margin-top: 5px;"> - SELF CHECK MODE </div>
7	When SHIPPING DATA RECOVERY ends, the data settings return to those at the time of shipping, and then the MEASURING MODE screen reappears.	<div style="border: 1px solid black; padding: 5px; width: fit-content;"> <div style="text-align: right;">20.0 %</div> 01.94 m³/h 00069401 </div>

5-8 : Description of error messages

Introduction

Errors are classified into critical failure and non-critical failure.

5-8-1 : Critical failure

Critical failure may obstruct the electromagnetic flowmeter operation, if not corrected, ultimately damage the flowmeter. When critical failure occurs during operation, an error message will appear on the converter's display and the electromagnetic flowmeter will continue to output the preset value in the abnormality treatment (failsafe) direction. The error message and the self-diagnostic results will be visible on the display.

Perform the proper correction measures, referring to the actions below.

Error code of critical failure

Error code	Error content	Action	LCD display
Err-02	CPU (ROM, RAM) CHECK SUM ERROR	1. Restore power.	Err - 02 CPU CHECK ERROR
Err-04	NVM READ AFTER WRITE ERROR	1. Restore power.	Err - 04 NVM CHECK ERROR
Err-05	AD converter error	1. Restore power.	Err - 05 ADC CHECK ERROR
Err-06	POWER supply is too low.	1. Check the power supply voltage.	Err - 06 POWER DOWN ERROR

5-8-2 : Non-critical error

Non-critical failures will not seriously affect electromagnetic flowmeter operation. When an error occurs during operation and is regarded as a non-critical problem by the converter self-diagnostics, the output will not burn-out and the electromagnetic flowmeter will continue to output the measured value.

If a wrong setting is found, an error message is displayed for a second, and then the screen set wrongly is displayed.

Error code of non-critical errors

Error code	Error content	Action	LCD display
Err-12	Upper/lower limit alarm set error HI < LO is set.	Set HI>LO.	<div style="border: 1px solid black; padding: 5px; width: fit-content;"> Err - 12 SETTING ERROR HI<LO </div>
Err-21	Span is set to 12 m/s or more.	Check the settings of flow rate range and detector information (bore diameter and detector type).	<div style="border: 1px solid black; padding: 5px; width: fit-content;"> Err - 21 SPAN ERROR OVER 12 m/s </div>
Err-22	Pulse frequency is too large or too small. The flow rate range unit system is different from the pulse unit system. Example: SPAN m ³ /h pulse scale t/h	1. Check pulse scale. 2. Check the setting of pulse frequency. 3. Adopt a unified unit system.	<div style="border: 1px solid black; padding: 5px; width: fit-content;"> Err - 22 PULSE WEIGHT SETTING ERROR </div>
Err-23	The pulse width is too large. When pulse frequency is output, the duty is 70% or more.	Check the following settings: 1. Pulse width 2. pulse scale 3. Span	<div style="border: 1px solid black; padding: 5px; width: fit-content;"> Err - 23 PULSE WIDTH OVER DUTY 70% </div>

Non-critical error (CALIBRATION MODE)

OVER LIMIT AUTO ZERO ERROR	<hr/> OVER LIMIT AUTO ZERO ERROR Display conditions: If the velocity is ± 0.2 m/s or more at zero adjustment. Displayed for 2 seconds (sub-indication)
OVER LIMIT AUTO SPAN ERROR	<hr/> OVER LIMIT AUTO SPAN ERROR Display conditions: If the input velocity is $\pm 30\%$ or more at gain adjustment. Displayed for 2 seconds (sub-indication)
INITIAL DATA RECOVERY	<hr/> INITIAL DATA RECOVERYDE Display conditions: When INITIAL DATA RECOVERY is executed. Displayed for 3 seconds (sub-indication) after rebooted and after the entire LCD indication is displayed.
SHIPPING DATA RECOVERY	<hr/> SHIPPING DATA RECOVERY Display conditions: When SHIPPING DATA RECOVERY is executed. Displayed for 3 seconds (sub-indication) after rebooted and after the entire LCD indication is displayed.

5-8-3 : Status indication

OVER LIMIT + 115.0%	<hr/> OVER LIMIT +115% Display conditions: If the present flow rate exceeds +115% of the measuring range. Blinks (main indication)
EMPTY STATUS	<hr/> EMPTY STATUS Display conditions: When the detector liquid level is at the electrode level or lower. Blinks (7-segment, two rows)
NOT CALIBRATED	<hr/> NOT CALIBRATED Display conditions: If no adjustments have been done (after INITIAL DATA RECOVERY). Blinks (main indication)
MEASURING MODE	<hr/> MEASURING MODE Display conditions: When returning to MEASURING MODE (after power-on, after setting is completed by the MODE key, and while internal arithmetic operation is taking place after communication). Displayed for 2 seconds (sub-indication)

Chapter 6 : Maintenance and troubleshooting

Outline of this chapter

This chapter presents an instrument maintenance and inspection procedure and information to refer to when doing troubleshooting. Ensure the measures to take according to the phenomena.

6-1 : Maintenance and inspection of hardware

6-1-1 : Replacement of indicator/data setter

Procedure

Replacement procedure is as follows.

Step	Procedure
1	Turn off the power to the converter. For the power-off, use a circuit breaker or the like.
2	The converter front cover is fixed by hexagon socket head screws (M3). Loosen these screws with an Allen wrench (1.5).
3	Remove the transducer front cover by turning it counterclockwise with the dedicated tool. ~Note <i>Remove the front cover straight toward you with care.</i>
4	Remove the 3 fixing screws. ~Note <i>The screws are not captive to the indicator/data setter, so take care not to drop them.</i>
5	Remove the indicator/data setter. ~Note <i>A cable is attached to the rear of the indicator/data setter. This cable is connected to the connector of the converter proper.</i>
6	Place the indicator/data setter in the desired direction and align it with the threaded holes in the converter proper.
7	Fix the indicator/data setter again using the three screws. ~Note <i>When tightening the screws, take care not to entangle and squeeze the cable.</i>
8	Attach the front cover. ~Note <i>Take care not injure your fingers on the cover edge or the thread in the main body.</i>

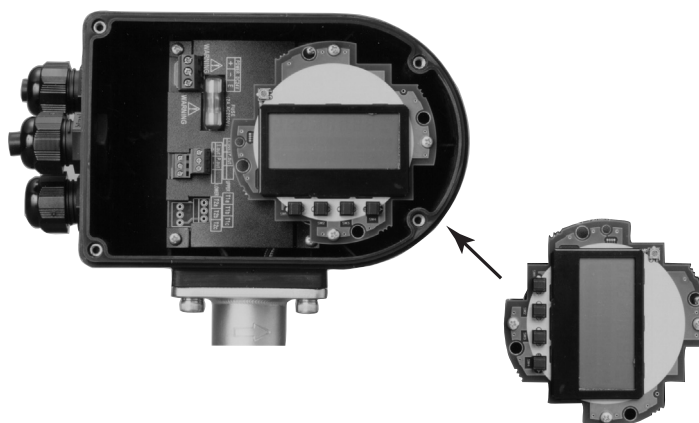

Figure 6-1 Replacement of indicator/data setter (with the cover removed)

6-2 : Troubleshooting

6-2-1 : Types of troubles

Introduction

The troubles that can occur when booting and starting up the instrument include the following three types:

- Troubles caused by inconsistencies between the specifications and actual service conditions of the instrument
- Troubles caused by mistakes in settings or operations
- Troubles caused by failures of the instrument

The troubles that can occur while running the instrument are divided into critical failures and non-critical failures as described below, and they are recognized, indicated or treated as such by the self-diagnosis function of the instrument.

If a trouble should occur, take the appropriate measure referring to the troubleshooting guide given here.

Critical failure

A critical failure is defined as a state or failure that causes a grave hindrance to the operation of the instrument and may lead to damage to the instrument itself if left untreated. If a grave trouble occurs while the instrument is running, an error message is displayed on the display panel of the main unit and the output continues to deliver the value that was set in the direction of abnormality processing

Non-critical failure

A non-critical failure is defined as a state or failure that does not cause a grave hindrance to the operation of the instrument. If some trouble occurs while the instrument is running but the instrument judges it by self-diagnosis as a minor trouble, the output does not switch to the abnormality processing output and the instrument continues to deliver the instantaneous flow rate value.

6-2-2 : Troubles at startup**Troubleshooting**

If a trouble should occur at the start of running, take measures according to the following table. If the trouble cannot be solved even if measures are taken according to the following table, the instrument may have broken down. Contact the nearest Azbil Corporation office or Azbil Corporation representative service offices.

Trouble	Points to check and measures
Nothing is displayed on the indicator when powered on.	<ul style="list-style-type: none">• Check the specifications of the power source.• Check the wiring.• Check that the ambient temperature is not under -4°F (-20°C).
No output is sent out when powered on.	<ul style="list-style-type: none">• Check the signal line for correct connection.
Pulse output is not delivered.	<ul style="list-style-type: none">• Check the counter type, input specifications and contact capacity.• Check the pulse setting of the flowmeter.

6-2-3 : Trouble during operation

Troubleshooting

If trouble occurs during operation, maintain in the following procedure.

1. Search for the symptom of the trouble in the table on this page. If found, maintain according to the table.
2. If communication is possible, read the error message and self-diagnosis results. Maintain referring to “Error messages and troubleshooting”.
3. If the above steps cannot solve the trouble, the instrument may have broken down. Contact the nearest our customer service offices.

Trouble	Check point and troubleshooting
The output value fluctuates with a much larger amplitude than the expected variation range of flow rate.	<ul style="list-style-type: none"> • Check that the instrument is grounded correctly. • Check that the damping time constant is set correctly. • Clean the electrodes.
The output value exceeds 100%.	<ul style="list-style-type: none"> • Check that the range is set correctly. • Check that zero is adjusted correctly.
The output value stays at 0%.	<ul style="list-style-type: none"> • Check that the signal line is connected correctly. • Check the upstream and downstream valves. • Check that the range is set correctly. • Isn't the instrument in the constant current mode? • Check that the flow rate is not within the set range of low-flow cutoff. • Check that the flow rate is not reversed (negative flow rate). • Check the detector for unfilled condition, too low conductivity, excessive noise, or the like.
The output is burnt out.	<ul style="list-style-type: none"> • Take measures referring to “Error messages and measures”.
The pulse output is too large or too small for the flow rate.	<ul style="list-style-type: none"> • Is the pulse setting (weight and width) correct? • Is the output from the main unit correct? • Is a pulse counter of appropriate specifications used? • Is the dropout value correctly set between 0 and 10%.

Document Number:	CM2-MCB100-2001
Document Name:	Magcube Electromagnetic Flowmeter General type Model: MCB10A User's Manual
Date:	1st edition: Apr. 2004 2nd edition: Aug. 2012
Issued/Edited by:	Azbil Corporation

Azbil Corporation