

Amplifier-Contained Compact Proximity Switches

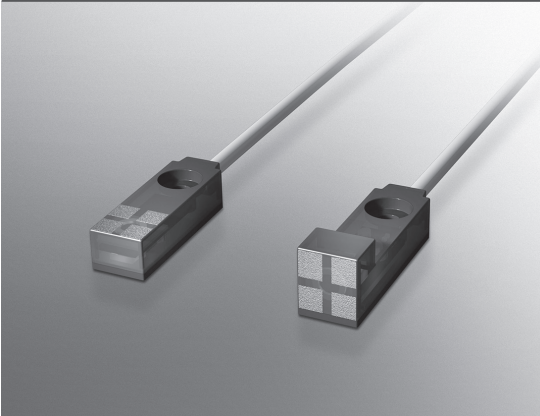

APM Series



Compact Proximity Switches Can be Installed Anywhere. Locking Boss Ensures Easy Mounting



- This thin 5.9 mm (side sensing type) switch takes up little space
- 8 mm wide, compact with a 2.5 mm sensing range
- Locking boss allows easy mounting by single screw. Mounting bracket not required. (locking boss type)
- Indicator lamp visible from all three directions allows easy checking of the operating state
- Wide variety of switch types support all kinds of applications.

ORDER GUIDE

● DC3-wire type

Appearance		Sensing distance (mm)	Location of sensing face	Locking boss	Output/operation mode (open collector)		Catalog listing	
Switch package style	Dimensions (mm) W×D×H				NPN	N.C.		
Top sensing type 	8 × D × H (sensing face) D=5.9 H=9.4 (body) D=21.6 H=5.9	2.5	Top	Not provided	NPN	N.O.	APM-A3A1	
						N.C.	APM-A3B1	
					Provided	PNP	N.O.	APM-A3D1
							N.C.	APM-A3E1
						NPN	N.O.	APM-B3A1
							N.C.	APM-B3B1
PNP	N.O.	APM-B3D1						
	N.C.	APM-B3E1						
Side sensing type 	8 × 25 × 5.9	2.5	Side	Not provided	NPN	N.O.	APM-C3A1	
						N.C.	APM-C3B1	
					Provided	PNP	N.O.	APM-C3D1
							N.C.	APM-C3E1
						NPN	N.O.	APM-D3A1
							N.C.	APM-D3B1
PNP	N.O.	APM-D3D1						
	N.C.	APM-D3E1						
Side sensing type 	8 × 25 × 7.5	2.5	Side	Not provided	NPN	N.O.	APM-C3A1-S	
						N.C.	APM-C3B1-S	
				Provided	NPN	N.O.	APM-D3A1-S	
						N.C.	APM-D3B1-S	

Note:



Different-frequency types also available for all models. These types are appended with the letter "F" is used.

Example: Different-frequency type of **APM-C3A1** is expressed as **APM-C3A1F**.

"Different-frequency type" is a type having an oscillation frequency different to that of the standard type to reduce the influence of mutual interference. Select this type when mounting two or more proximity sensors close to each other.

For details, contact your nearest Azbil dealer.

●DC2-wire type

Appearance		Sensing distance (mm)	Location of sensing face	Locking boss	Operation mode	Catalog listing	
Switch package style	Dimensions (mm) W × D × H						
 Top sensing type	8 × D × H (sensing face) D = 5.9 H = 9.4 (body) D = 21.6 H = 5.9	2.5	Top	Not provided	N.O.	APM-A3J1	
					N.C.	APM-A3K1	
				Provided	N.O.	APM-B3J1	
					N.C.	APM-B3K1	
 Side sensing type	8 × 25 × 5.9		2.5	Side	Not provided	N.O.	APM-C3J1
						N.C.	APM-C3K1
					Provided	N.O.	APM-D3J1
						N.C.	APM-D3K1
 Side sensing type	8 × 25 × 7.5	2.5		Side	Not provided	N.O.	APM-C3J1-S
						N.C.	APM-C3K1-S
					Provided	N.O.	APM-D3J1-S
						N.C.	APM-D3K1-S

SPECIFICATIONS

●DC3-wire type

Item	Standard catalog listing			
	APM-□3A1□ (-S)	APM-□3B1□ (-S)	APM-□3D1□	APM-□3E1□
Actuation method	High-frequency oscillation type (unshielded type)			
Rated supply voltage	12/24Vdc			
Rated sensing distance	2.5mm, ±15%			
Usable sensing distance	0 to 1.8mm			
Standard target object	15 × 15mm, 1mm thick iron			
Differential travel	15% max. of sensing distance			
Operating voltage range	10.8 to 26.4Vdc (ripple voltage 10% max.)			
Current consumption	10mA max.			
Output mode	NPN transistor open collector		PNP transistor open collector	
Operation mode	Normally open (N.O.)	Normally closed (N.C.)	Normally open (N.O.)	Normally closed (N.C.)
Control output	Switching current	30mA max. (resistive load)		
	Voltage drop	1V max. (switching current 30mA)		
	Output dielectric strength	26.4V		
Operating frequency	120Hz			
Hysteresis	0.05mm max.			
Temperature characteristics	±15% max. for the range of -10 to +55°C when +25°C is taken as standard temperature in sensing distance			
Supply voltage characteristics	±2% max. with ±10% voltage fluctuation with rated supply voltage as standard voltage in sensing distance			
Indicator lamps	Lights (orange) when object approaches			
Operating temperature range	-10 to +55°C			
Storage temperature range	-25 to +70°C			
Operating humidity range	35 to 85% RH			
Insulation resistance	50MΩ min. (by 500Vdc megger)			
Dielectric strength	1,000Vac, 50/60Hz for 1 minute between case and electrically live metals			
Vibration resistance	10 to 55Hz, 1.5mm peak-to-peak amplitude, 2hrs in X, Y and Z directions			
Shock resistance	500m/s ² 3 times in X, Y and Z directions			
Protection	IP67 (IEC 529)			
Weight	Approx. 10g			
Circuit protection	Surge absorption, reverse connection protection circuit			
Wiring method	Pre-leaded (oil-resistant cord: 2.5mm O.D., 0.1mm ² , 3-core, 1m)			
Case material	Polyallylate resin			
Tightening torque	0.5N·m (M2.6 screw)			

Note:

Normally open: Load operates when object approaches the switch (output circuit ON when detected).

Normally closed: Load is reset when object approaches the switch (output circuit ON when not detected).

●DC2-wire type

Standard catalog listing	APM-□3J1(-S)		APM-□3K1(-S)	
Actuation method	High-frequency oscillation type (unshielded type)			
Rated supply voltage	12/24Vdc			
Rated sensing distance	2.5mm, ±15%			
Usable sensing distance	0 to 1.8mm			
Standard target object	15 × 15mm, 1mm thick iron			
Differential travel	7% max. of sensing distance			
Operating voltage range	10 to 30Vdc			
Leakage current	0.65mA max. (24Vdc)			
Operation mode	Normally open (N.O.)		Normally closed (N.C.)	
Control output	Switching current	3 to 50mA		
	Voltage drop	3V max.		
	Output dielectric strength	30Vdc		
Operating frequency	1,500Hz			
Temperature characteristics	±10% max. for the range of -10 to +55°C when +25°C is taken as standard temperature in sensing distance ±15% max. for the range of -25 to +70°C when +25°C is taken as standard temperature in sensing distance			
Supply voltage characteristics	±2% max. with ±10% voltage fluctuation with rated supply voltage as standard voltage in sensing distance			
Indicator lamps	Lights (orange) when object approaches			
Operating temperature range	-10 to +55°C (Note 1)			
Storage temperature range	-25 to +70°C			
Insulation resistance	50MΩ min. (by 500Vdc megger)			
Dielectric strength	1,000Vac, 50/60Hz for 1 minute between case and electrically live metals			
Vibration resistance	10 to 55Hz, 1.5mm peak-to-peak amplitude, 2hrs in X, Y and Z directions			
Shock resistance	500m/s ² 3 times in X, Y and Z directions			
Protection	IP67			
Weight	Approx. 10g			
Circuit protection	Surge absorption, reverse connection protection circuit			
Wiring method	Pre-leaded (oil-resistant cord: 2.5mm O.D., 0.1mm ² , 2-core, 1m)			
Case material	Polyallylate resin			
Tightening torque	0.5N-m (M2.6 screw)			

Note 1: -25 to +70°C when **APM-PA01** mounting bracket (sold separately) is used.

WIRING DIAGRAMS

DC3-wire type

- NPN transistor, open collector type
(Catalog listing **APM-□3A1□**, **APM-□3B1□**)

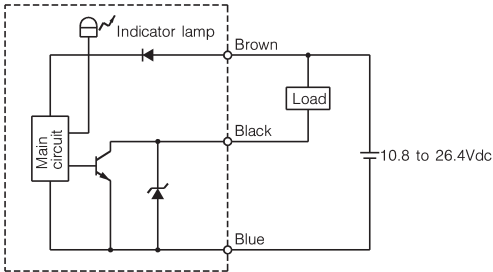

- PNP transistor, open collector type
(Catalog listing **APM-□3D1□**, **APM-□3E1□**)

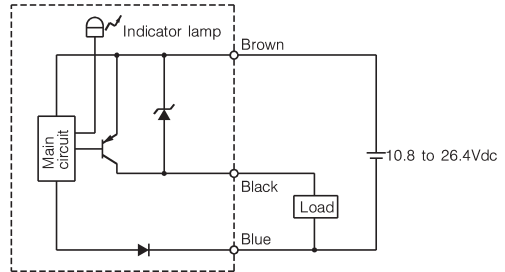

DC2-wire type

- All catalog listing

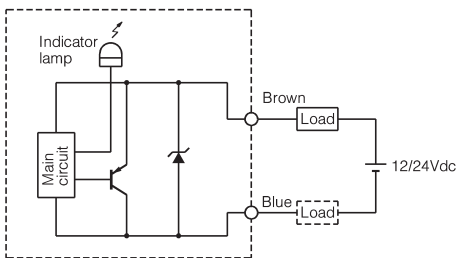

The load can be connected to either of the power supplies.

SENSING AREA DIAGRAMS (typical examples)

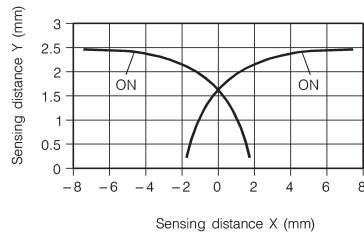
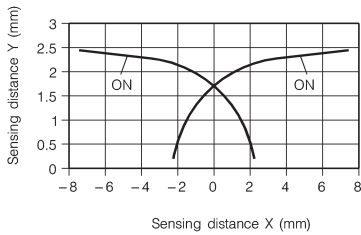

SENSING DISTANCE ACCORDING TO MATERIAL & SIZE OF OBJECT (typical examples)

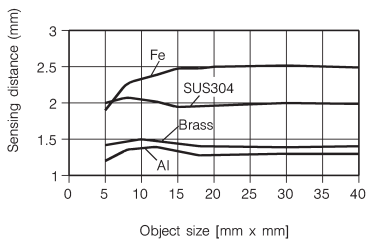

EXTERNAL DIMENSIONS

(unit: mm)

- Top sensing type
- Without locking boss

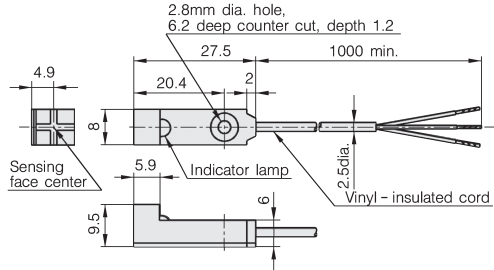

- Vinyl-insulated cord (oil-resistant: 0.1 mm², 0.08 dia. /19, 3-core) 2.5mm dia
- DC 2-wire type: 2 cores

- With locking boss

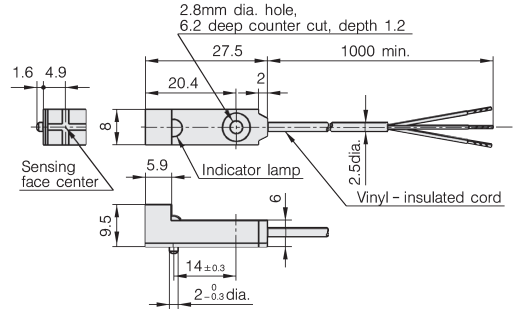

- Vinyl-insulated cord (oil-resistant: 0.1 mm², 0.08 dia. /19, 3-core) 2.5mm dia
- DC 2-wire type: 2 cores

- Side sensing type
- Without locking boss

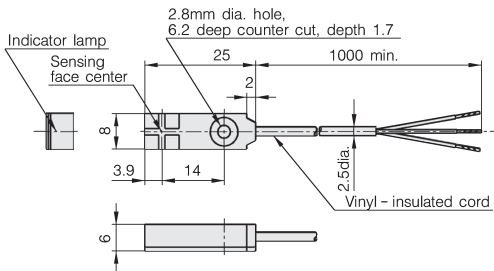

- Vinyl-insulated cord (oil-resistant: 0.1 mm², 0.08 dia. /19, 3-core) 2.5mm dia
- DC 2-wire type: 2 cores

- With locking boss

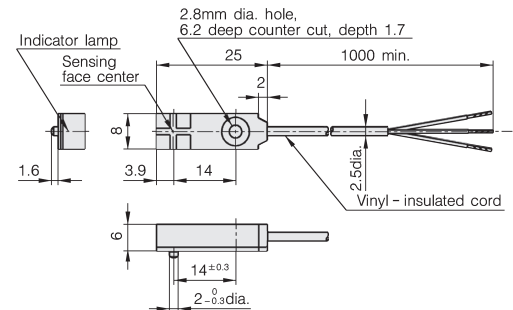

- Vinyl-insulated cord (oil-resistant: 0.1 mm², 0.08 dia. /19, 3-core) 2.5mm dia
- DC 2-wire type: 2 cores

- Side sensing type (-S)
- Without locking boss

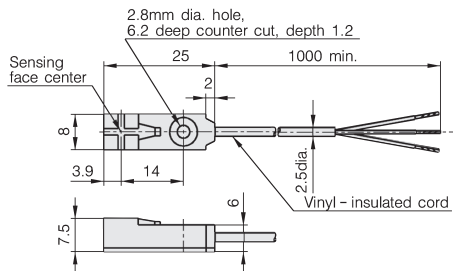

- Vinyl-insulated cord (oil-resistant: 0.1 mm², 0.08 dia. /19, 3-core) 2.5mm dia
- DC 2-wire type: 2 cores

- With locking boss

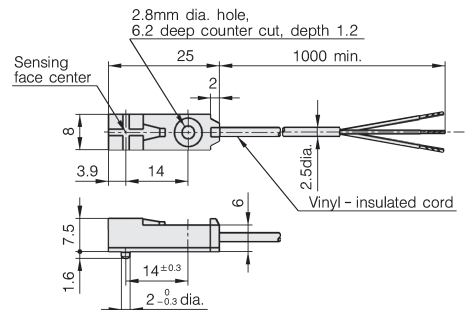

- Vinyl-insulated cord (oil-resistant: 0.1 mm², 0.08 dia. /19, 3-core) 2.5mm dia
- DC 2-wire type: 2 cores

PRECAUTIONS

1. Mounting

This switch is provided with an M2.6 screw (neck length 12mm), hexagonal head unit, plain washer and spring washer. Tighten the screw to the torque shown below.

Allowable tightening torque	Recommended screw diameter
0.5N-m	M2.6

2. Influence of surrounding metal

Metal other than the object surrounding the switch may influence operating characteristics. Maintain the following space between the switch and surrounding metal:

Side (mm)	Top (mm)
A=8	B=8, C=10

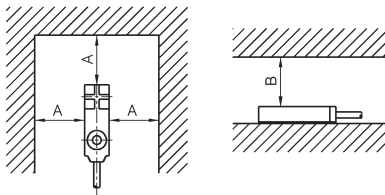

Side sensing type

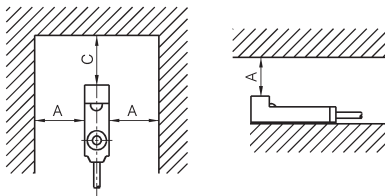

Top sensing type

3. Mutual interference prevention

When mounting proximity switches in parallel or facing each other, mutual interference may cause the switch to malfunction. Maintain at least the spaces indicated in the figures above. When alternately mounting standard-frequency types and different-frequency types (Catalog listing **APM-□3□1F**) in a row, maintain at least the space indicated by the figure in parentheses for both dimensions A and B.

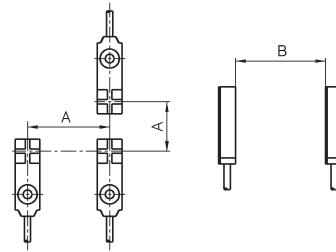

Side sensing type

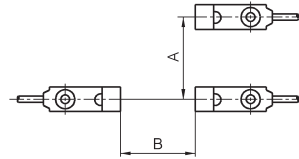

Top sensing type

Facing each other isolation	A (mm)	B (mm)
Side sensing type	28(0)	40(10)
Top sensing type	28(0)	40(10)

4. Operation upon power ON

After the power is turned ON, it takes 40ms or less until the proximity switch is ready for sensing.

When the load and the proximity switch use different power supplies, be sure to turn the proximity switch ON before turning the load ON.

5. Minimum cable bend radius (R)

The minimum bending radius (R) of the cord is 10mm. Take care not to excessively bend the cord beyond this radius. Also, do not excessively bend the cord within 30mm of the cord lead-in port.