

# Holder Ring Assemblies

## Model NOH

The Holder Ring Assembly is a combination of a holder ring and an orifice plate designed for ring-type-joint (RTJ) flanges of ANSI or JPI Specifications. The holder ring has a function of holding the orifice plate and also a function as a gasket to prevent leakage of the process fluid. This metallic sealing system is applicable to a fluid at high temperature and high pressure. The pressure tapping system normally is of the flange tap type.

### Standard Specifications

**Types of orifices bores:**

- Regular-edge concentric bore,
- Quadrant-edge concentric bore

**Calculation standards:**

- Regular-edge concentric bore:  
JIS Z8762-1969 (ISO R541-1967)

- Quadrant-edge concentric bore:  
Shell Flow Meter Engineering Handbook,  
1968

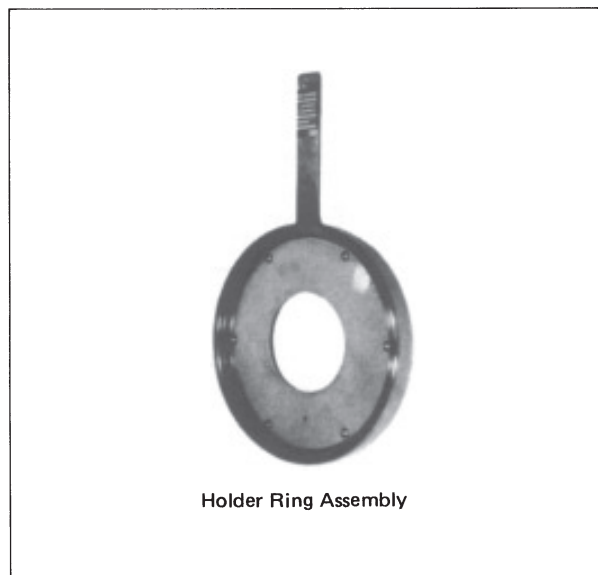

Holder Ring Assembly

**Available ranges**

**1) Holder Rings and Orifice Plates**

Type of orifice bore	Tapping system	Nominal diameter	Flange specification [*2]	Plate thickness (mm)	Plate material	Shape of holder ring sealing plane	Holder ring material [*4]	$\beta$ ; Limit of diameter ratio for restriction (D2/D1) [*5]
Regular-edge concentric bore	Flange taps	1½" to 14" [*1]	ANSI (or JPI) 300, 600 1b	1½" to 6"=3	SUS304	Octagonal [*3]	Soft iron for industrial-use grade, SUSF304, SUSF316	1½"=0.10~0.50 2"=0.10~0.60 2½"=0.10~0.65 3"=0.10~0.70 4"=0.10~0.75
Quadrant-edge concentric bore		1½" to 10"		8" to 14"=5	SUS316			1½"=0.20~0.50 2"=0.20~0.60 2½"=0.20~0.65 3"=0.20~0.70

**Notes**

- (\*1): The regular-edge concentric bore orifice for 1½" pipe is available, although it is not covered by the standard specifications.
- (\*2): The dimensions of ANSI and JPI flanges are identical.
- (\*3): Oval shapes also are available upon special order.
- (\*4): Other material also are available.  
[Ex. SFHV12B (ASTM F1 equivalent), SFHV23B (ASTM F11 equivalent. etc.)]
- (\*5):  $\beta$ : Diameter ratio of restriction is checked using a nomograph. Request it if required.

# Model No. Table

Basic Model No.	Selectable specifications				Optional specification (orifice plate)						Description		
	I	II	III	IV	V	VI			VII	VIII			
	Specifi- cation	Pressure rating	Nominal pipe diameter	Holder ring material	Type of orifice bore	Tapping system	Available range			Material		Thickness	Avail- able range
NOH												Holder ring assembly	
-P		300										JPI 300RTJ	
		600										" 600RTJ	
-A		300										ANSI 300RTJ	
		600										" 600RTJ	
			040				○	○				○	Pipe size 1½"
			050				○	○				○	" 2"
			065				○	○				○	" 2½"
			080				○	○				○	" 3"
			100				○	○	○	○		○	" 4"
			125				○	○	○	○		○	" 5"
			150				○	○	○	○		○	" 6"
			200				○	○	○	○		○	" 8"
			250				○	○	○	○		○	" 10"
			300				○	○	○	○		○	" 12"
			350				○	○	○	○		○	" 14"
				1									Soft iron
				2									SUS316
				7									SUS304
					-C	2	┘						Regular-edge concentric bore, flange taps
					-Q	2	┘						Quadrant-edge concentric bore, flange taps
					-E	2		┘					Eccentric bore, flange taps
					-S	2			┘				Segment opening, flange taps
									2				SUS316
									7				SUS304
										03	┘		3mm
										05	┘		5mm

## Dimensions

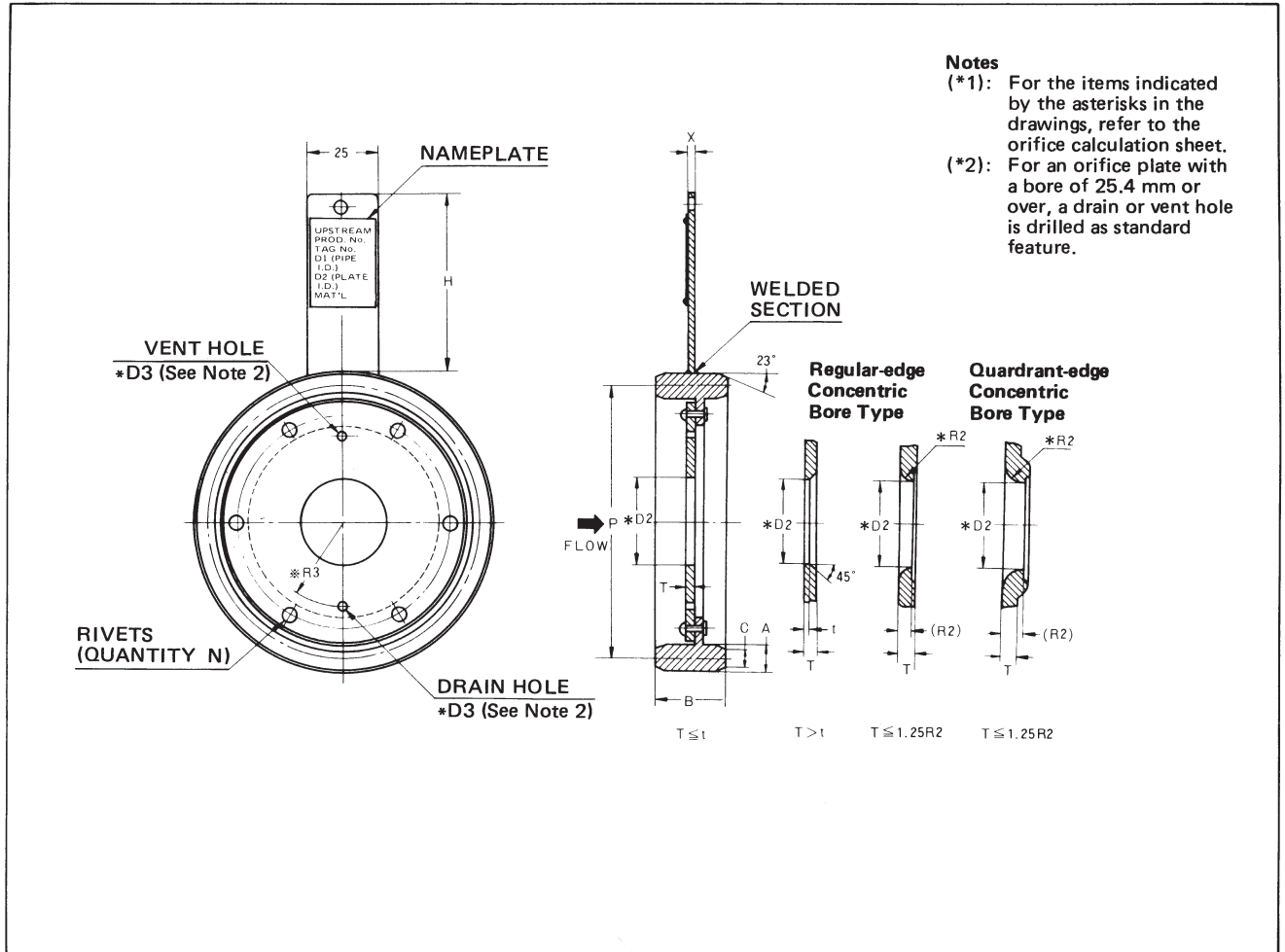

### Table of Dimensions

(Unit: mm)

Nominal pipe diameter (inch)	Holder ring				Orifice plate		Handle (tab)		No. of rivets N
	Pitch dia. P	Width A	Height B	Width of flat section C	Plate thickness T	Edge thickness t	Height H	Thickness X	
1½	68.262	7.938	26	5.232	3	0.5	110	2	4
2	82.550	11.112	26	7.747	3	0.8	110	2	4
2½	101.600	11.112	26	7.747	3	1.0	110	2	4
3	123.825	11.112	26	7.747	3	1.0	110	2	6
4	149.225	11.112	26	7.747	3	1.5	125	3	6
5	180.975	11.112	26	7.747	3	2.0	140	3	6
6	211.138	11.112	26	7.747	3	2.0	140	3	6
8	269.875	11.112	28	7.747	5	3.0	140	3	6
10	323.850	11.112	28	7.747	5	3.0	150	3	6
12	381.000	11.112	28	7.747	5	5.0	150	3	6
14	419.100	11.112	28	7.747	5	5.0	150	3	6

Please read the "Terms and Conditions" from the following URL before ordering or use:

<http://www.azbil.com/products/bi/order.html>

*Specifications are subject to change without notice.*

The logo for Azbil Corporation, featuring the word "azbil" in a bold, lowercase, sans-serif font.

---

**Azbil Corporation**  
Advanced Automation Company

1-12-2 Kawana, Fujisawa  
Kanagawa 251-8522 Japan  
URL: <http://www.azbil.com/>

3rd Edition: Issued in Feb. 2015

*No part of this publication may be reproduced or duplicated  
without the prior written permission of Azbil Corporation.*