



AT9000 Advanced Transmitter Model GTX Application Guide



Contributing to safety plant operation

Providing the safety transmitter with high performance and high quality.

Sensor and Characterization (●)

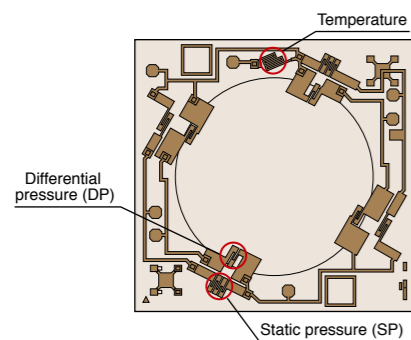

- 1. Piezo resistance sensor**
The differential pressure, static pressure and temperature sensors are on one piezo resistance sensor.
- 2. Characterization**
To realize high accuracy and high stability, of each particular transmitter, data on differential pressure, temperature and static pressure characteristics are acquired when the instruments is manufactured and the acquired data is stored in the ROM.

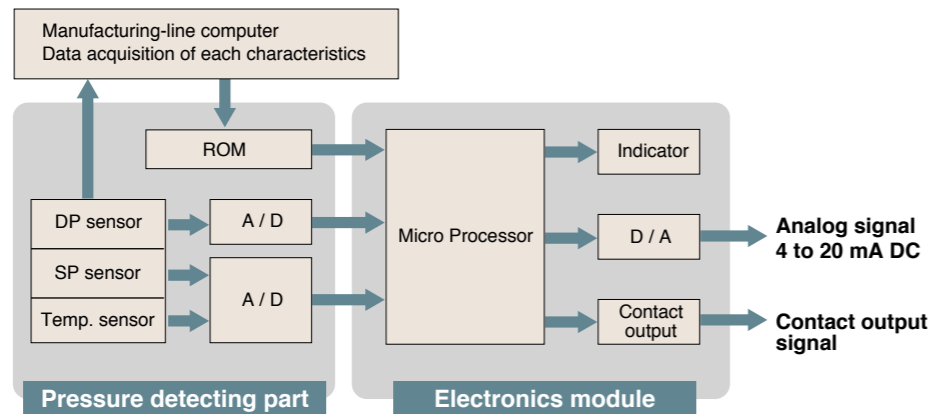

Features

Safety design

Safety design complying with the IEC61058 standard: Certified according to Safety Integrity Level2 (SIL2). Being used as a component of Safety Instrumented System (SIS).

Equipped with the ALARM and the contact output function (OPTIONAL).

In case of failure based on the transmitters set-point for PV, and Sensor Temperature, give the early alarming information. And the ALARM status can be displayed and confirmed on the built-in-indicator (◆).

Indicator (◆)

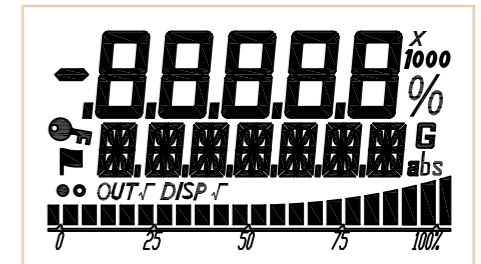

High performance and reliability

Unique compensation system "Characterization(●)" has been improved to achieve higher performance.

Accuracy $\pm 0.04\%$ F.S. and $\pm 0.1\%$ of URL stability for 10 years has been achieved.

Significantly reducing calibration work after installation.

Fast response

The response time within 100 msec(■) is realized. Suitable for pressure control around turbine.

High turn-down ratio

Turn-down ratio of 200:1 has been realized. Contributes to reducing the amount of inventory required for spare parts.







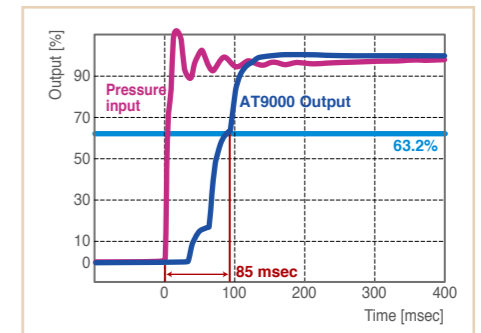

Proven technology



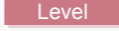



The silicon sensor chip consists of three sensors, which are temperature, differential pressure and static pressure sensor to correct non-linearity of each transmitter. This unique compensation system enables to eliminate the influence of ambient temperature and static pressure changes on transmitter output characteristics.

Response Time (■)



Extensive Product Lineup

Impulse-line model						Transmitter type	Transmitter type	Impulse-line model							
															
Application						Application						Application			
Model	GTX15D	GTX30D	GTX31D	GTX40D	GTX41D	GTX71D	Model	GTX32D	GTX42D	GTX72D	GTX60G	GTX71G	GTX82G		
Measuring span	0.1 to 2 kPa	0.5 to 100 kPa	0.5 to 100 kPa	35 to 700 kPa	35 to 700 kPa	0.25 to 14 MPa	Measuring span	0.5 to 100 kPa	35 to 700 kPa	0.25 to 14 MPa	17.5 to 3500 kPa	0.7 to 14 MPa	0.7 to 42 MPa		
	0.4 to 8 inH ₂ O	2 to 400 inH ₂ O	2 to 400 inH ₂ O	5 to 100 psi	5 to 100 psi	36 to 2,000 inH ₂ O		2 to 400 inH ₂ O	5 to 100 psi	36 to 2,000 psi	2.5 to 500 psi	100 to 2,000 psi	100 to 6,000 psi		
Accuracy	±0.15%	±0.04%	±0.04%	±0.1%	±0.1%	±0.15%	Accuracy	±0.04%	±0.1%	±0.15%	±0.04%	±0.15%	±0.15%		
Maximum working pressure	210 kPa	3.5 MPa	21 MPa	3.5 MPa	21 MPa	21 MPa	Maximum working pressure	42 MPa	42 MPa	42 MPa	3.5 MPa	14 MPa	42 MPa		
	30 psi	500 psi	3,000 psi	500 psi	3,000 psi	3,000 psi		6,000 psi	6,000 psi	6,000 psi	500 psi	2,000 psi	6,000 psi		
Used for	For steel furnace pressure control, clean room internal pressure control				A wide range of measurements, such as differential pressure flow measurement and level measurement		Used for	High static pressure applications, such as electric power plant vapor pressure/flow measurement					Monitoring/control of internal vessel pressure and internal pipe pressure		

Impulse-line model		Flange type		Remote-seal type		Transmitter type	Transmitter type	Remote-seal type						
														
Application						Application						Application		
Model	GTX30A	GTX60A	GTX35F	GTX60F	GTX35R	GTX40R	Model	GTX35U	GTX60U	GTX71U	GTX82U	GTX30S	GTX60S	
Measuring span	4 to 104 kPa abs	35 to 3,500 kPa abs	2.5 to 100 kPa	70 to 3,500 kPa	2.5 to 100 kPa	35 to 700 kPa	Measuring span	2.5 to 100 kPa	35 to 3,500 kPa	0.7 to 14 MPa	0.7 to 42 MPa	4 to 104 kPa abs	35 to 3,500 kPa abs	
	30 to 780 mmHg	260 to 26,000 mmHg	10 to 400 inH ₂ O	10 to 2,000 psi	10 to 400 inH ₂ O	5 to 100 psi		10 to 400 inH ₂ O	5 to 500 psi	100 to 2,000 psi	100 to 6,000 psi	30 to 780 mmHg	260 to 26,000 psi	
Accuracy	±0.15%	±0.15%	±0.2%	±0.15%	±0.2%	±0.2%	Accuracy	±0.2%	±0.2%	±0.2%	±0.2%	±0.25%	±0.25%	
Maximum working pressure	104 kPa abs	3,500 kPa abs	Based on flange rating	Based on flange rating	Based on flange rating	Based on flange rating	Maximum working pressure	Based on flange rating	Based on flange rating	Based on flange rating	42 MPa	104 kPa abs	Based on flange rating	
	780 mmHg	26,000 mmHg									6,000 psi	780 mmHg		
Used for	Monitoring/control of internal vessel pressure in cases where absolute pressure measurement is required		Measurement of corrosive/adhesive/slurry fluids		Measurement of high temperature/high vacuum/corrosive/adhesive/slurry fluids		Used for	Measurement of high temperature/high vacuum/corrosive/adhesive/slurry fluids					Monitoring/control of internal vessel pressure and in cases where absolute pressure measurement is required	

*The wetted part temperature range and ambient temperature effect are limited depending on the model and specifications. For details, please refer to the specification sheets.

Our solutions for various applications

Applications/ Fueture	Pages	Model	
Impulse-line less instrumentation	P7		
1/2 inch. remote-seal transmitter achieves impulse-line less instrumentation. Flow Pressure Level		1/2 inch. remote-seal transmitter	GTX __R GTX __U
Support for fast response applications	P7		
Remote-seal transmitter with fast response. Improves controllability on control lines and in cold areas. Flow Level		Fast response remote-seal transmitter	GTX __R
Direct mount instrumentation	P8		
The direct mount instrumentation provides less install cost and maintenance cost. Pressure		In-line pressure transmitter	GTX __G
Support for level measurement with Temperature Compensation	P8		
Remote-seal transmitter's fill fluid density compensation function achieves level measurement with only small effects from changes in ambient temperature. Level		Remote-seal transmitter with ambient temp. compensation	GTX __R
Support for level measurement in tight space	P8		
A special kit is used for the remote-seal transmitter capillary tube section, improving temperature effect and saving space. Level		Remote-seal transmitter with directmounting kit	GTX __R
Support for vacuum applications	P9		
This is well suited for applications requiring high temperature and high vacuum conditions, such as reactions, distillation, drying and recovery. Pressure Level		High-temperature, High-vacuum remote-seal transmitter Remote-seal type absolute pressure transmitter	GTX __R GTX __U GTX __S
Anti-hydrogen permeation measures	P10		
We suggest this as the most effective way to deal with various modes of hydrogen permeation. Flow Pressure Level		Anti-hydrogen permeation transmitter	ALL
Anti-hydrogen embrittlement measures	P10		
With its platinum chip construction, this product is recommended to prevent hydrogen embrittlement. Flow Pressure Level		Anti-hydrogen embrittlement transmitter	ALL

Flow **Pressure** **Level**

Impulse-line less instrumentation

With the impulse-line less instrumentation provided using the small diameter (1/2", 3/4") process connection pressure / differential pressure remote-seal transmitter, the various problems caused by connecting impulse-line clogging, the cost of labor for maintenance work, etc. are avoided. Used especially in petroleum, petrochemical, and chemical plants, this product has an extensive record of achievement.

Features

- Reduces operating costs (seal liquid costs, steam tracing running costs).
- Easy installation (flange connection, fixing of stanchions for main unit).
- Reduces maintenance operations (replacement/refilling of seal liquid, steam tracing, removal of blockages from connecting pipes).
- Reduces dangerous operations (leak checking, removal of blockages from connecting pipes, replacement/refilling of seal liquid).
- Environmentally friendly (elimination of seal liquid, elimination of connecting pipes/steam tracing/seal pots, etc.).
- Greatly reduces the heating costs incurred by connecting pipes and steam tracing.

Model 1/2 inch. remote-seal transmitter GTX __R
GTX __U

1/2 inch. remote-seal transmitter



Flow **Level**

Support for fast response applications

In some cases of flow control by a differential pressure remote seal transmitter, responsiveness on a par with impulse-line instrumentation is required. In other cases, in cold regions or inland areas where winter air temperature drops below freezing, improvements in control are necessary due to reduced responsiveness. In answer to these and similar needs, we present our fast-response remote seal transmitter.

Features

- Faster response time from the remote seal. Achieves responsiveness on a par with impulse-line model.
- Improved responsiveness in low temperatures. Responsiveness in low temperatures (below the freezing point) has been improved, reducing the effect of seasonal temperature changes.

Model Fast response remote-seal transmitter GTX __R

Fast response remote-seal transmitter

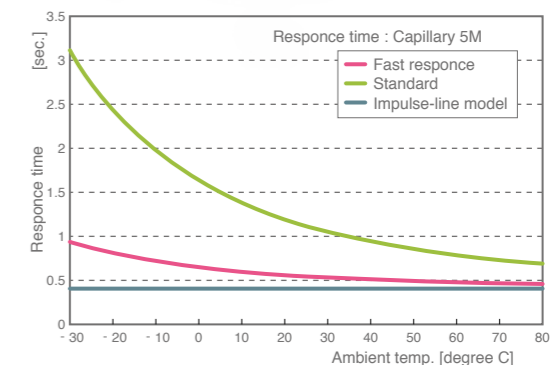

Pressure

Direct mount instrumentation

The direct mount instrumentation delivers less install cost and maintenance cost comparing with impulse line instrumentation.

Features

- Reduces initial cost, impulse line instrumentation work and material costs.
- Reduces maintenance operations.
- Reduces impulse line heating costs.

Model In-line pressure transmitter GTX __G

In-line pressure transmitter



Level

Support for level measurement with Temperature Compensation

As a standard feature, our differential pressure remote seal transmitters are equipped with a function that compensates for changes in the density of the fill fluid due to variations in ambient temperature. As a result, for liquid-level measurement by differential pressure remote seal transmitter, zero point shifts resulting from changes in fill fluid head pressure ($P = \rho gL$) due to variations in ambient temperature are eliminated.

Features

- Keeps zero point shift to 1/5 or below.
- A standard feature on all remote seal transmitters .
- Ideal for design changes or use of spares, because the distance between the flanges can be optionally changed by the communicator.

Model Remote-seal transmitter with ambient temp. compensation GTX __R

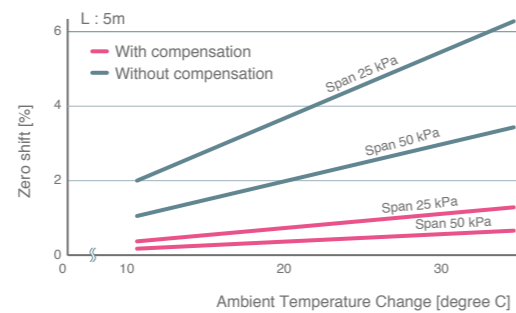
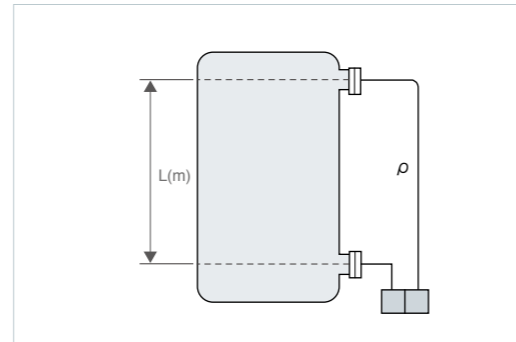

Level

Support for Level Measurement in tight space

A solution to many of the issues that affect differential pressure transmitters: dealing with the bottom flange capillary tube, reducing the space occupied by the 2" stanchion pipe, zero point shift caused by temperature differences between the high/low capillary tubes, and others.

Features

- Easy-to-use instrumentation
 - Direct mount using flange adaptor. No need for a 2" stanchion pipe.
 - Capillary tubes are neatly held in place by tube clamps.
 - Deals easily with changes in vessel spacing distance.
 - Flange adaptor and tube clamp can be applied to existing equipment using an adapted flange.
- Improves ambient temperature characteristics
 - Capillary tubes are held firmly in place by tube clamps. Because of this, the zero point shift caused by temperature differences between the high/low capillary tubes due to changes in ambient temperature is reduced to its previous value.

Model Remote-seal transmitter with directmounting kit GTX __R

Instrumentation with Directmounting kit

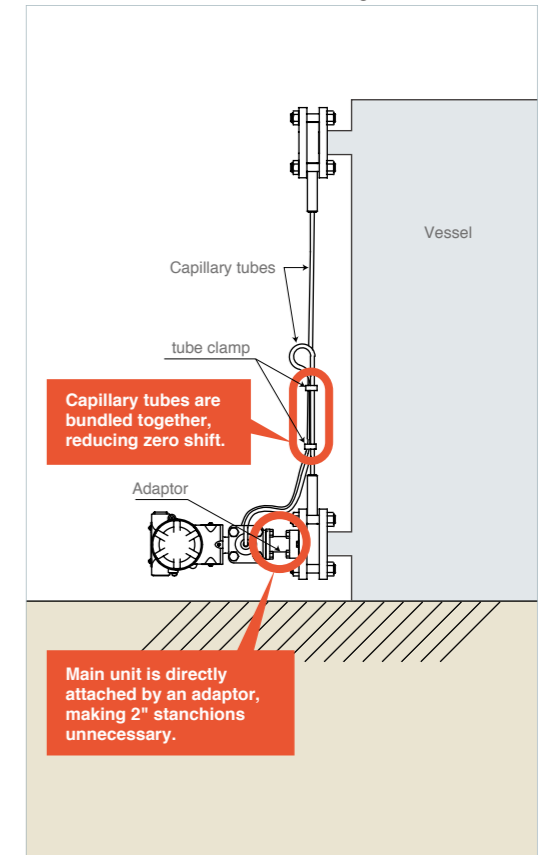

Pressure Level

Support for Vacuum Applications

The pursuit of higher efficiency in plant operations in a wide range of industries—notably petroleum/petrochemical/chemical, as well as semiconductor, pharmaceutical, etc.—has resulted in requirements for process measurement under high temperature, high vacuum conditions. In response to these stringent customer requirements, we offer our vacuum application series product line.

Supporting Technology

Baking processes to expel gas from wetted metal parts, high-temperature vacuum degassing processes to avoid the effect of low molecular mass impurities within seal liquids, sealing processes to avoid reduction of heat resistance in seal liquids, etc.—we have developed three technologies with built-in reliability in order to thoroughly suppress unwanted effects.

Model High-temperature, High vacuum remote-seal transmitter GTX __R
 Remote-seal type absolute pressure transmitter GTX __U
 GTX __S

Remote-seal type absolute pressure transmitter



These devices are used in various applications in combination with pressure / differential pressure transmitters.

Flow Pressure Level

Anti-hydrogen permeation measures

With transmitters used in petroleum/petrochemical plants, seawater processing plants, etc., problems are sometimes caused by diaphragm permeation by hydrogen gas. Our transmitters possess anti-hydrogen permeation technology developed through research over many years, and enjoy a long record of success in the field.

1. Hydrogen Permeation under High Temperature, High Pressure Conditions

Mechanism

Under high temperature, high pressure conditions in petroleum/petrochemical plants, mainly in lines rich in H₂S and H₂, hydrogen atoms dissociated from hydrogen molecules permeate the metal diaphragm and form hydrogen molecules again within the diaphragm.

Preventative Measures

Wetted surfaces of the diaphragm that include welded parts are gold plated, thereby preventing adsorption of hydrogen atoms.

2. Electrochemical Hydrogen Permeation

Mechanism

Mainly in seawater processing plants and the like, where the diaphragm material and the cover flange material are different, the combination of different metals causes a localized battery effect which results in hydrogen molecules dissociating into hydrogen atoms, permeating the flange, and forming hydrogen molecules again within the diaphragm.

Preventative Measures

To prevent the localized battery effect responsible for hydrogen formation, the following measures are used:

The diaphragm and cover flange are made of the same material (316 SST).

The diaphragm surface is coated with an insulating FEP.

Model Anti-hydrogen permeation transmitter ALL

Mechanism under high temperature, high pressure conditions

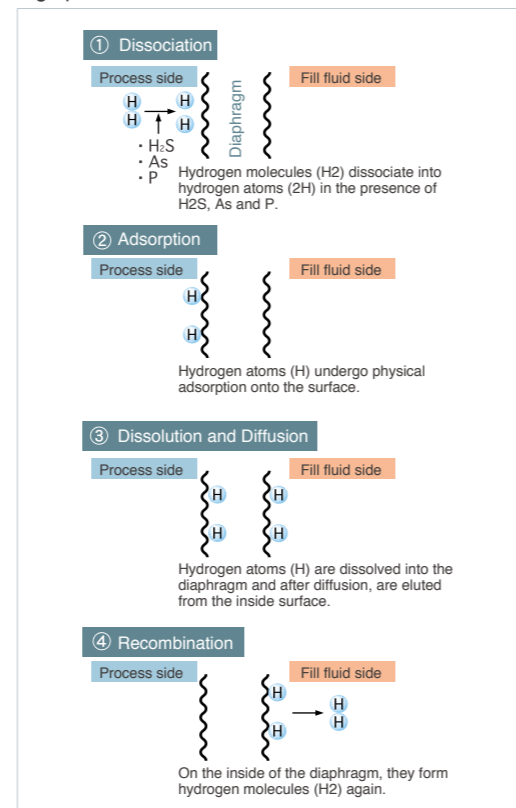

Electrochemical Mechanism

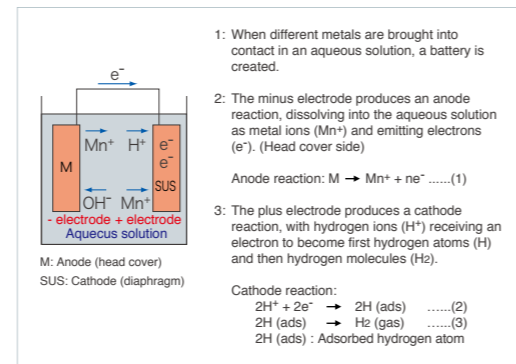

Magnified view of center part

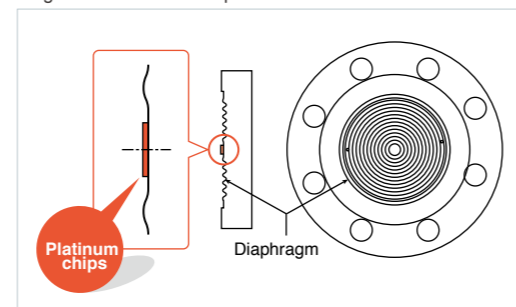

Flow Pressure Level

Anti-hydrogen embrittlement measures

In hydrogen-rich processes, such as in petroleum and petrochemical plants, when tantalum is used as the diaphragm material, it can become brittle from exposure to hydrogen gas.

Mechanism

In hydrogen-rich processes, when the diaphragm is made of tantalum, hydrogen gas is adsorbed into the tantalum and embrittles it.

Preventative Measures

Platinum (Pt) chips are welded onto the center of the diaphragm, protecting the diaphragm surface itself by a sacrificial electrode effect.

Model Anti-hydrogen embrittlement transmitter ALL

Manifold Valve

Model MVG

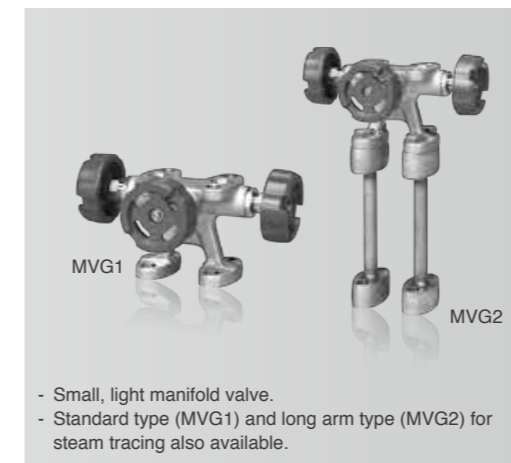

Integral Orifice Assembly For Minute flow Measurement

Model KEE

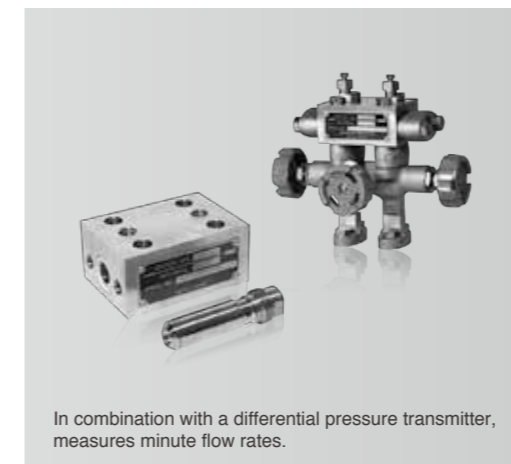

Commstaff Smart Communicator

Model CFS100



Filed Type Analog Meter

Model NWA300



We create value together with customers at their site through human-centered automation.

We solve issues in a wide array of industries, from oil refining, chemical, iron and steel, pulp and paper to automobiles, electrical/electronic, semiconductor, and foods and beverages, through the provision of products, solutions, instrumentation, engineering and maintenance service to support optimal operation of the customers' facilities throughout their lifecycle. Collaborating with people involved in production, we develop advanced measurement and control technologies, and strive to realize a production site where workers can develop their own skills in safety, thus creating new value for our customers.

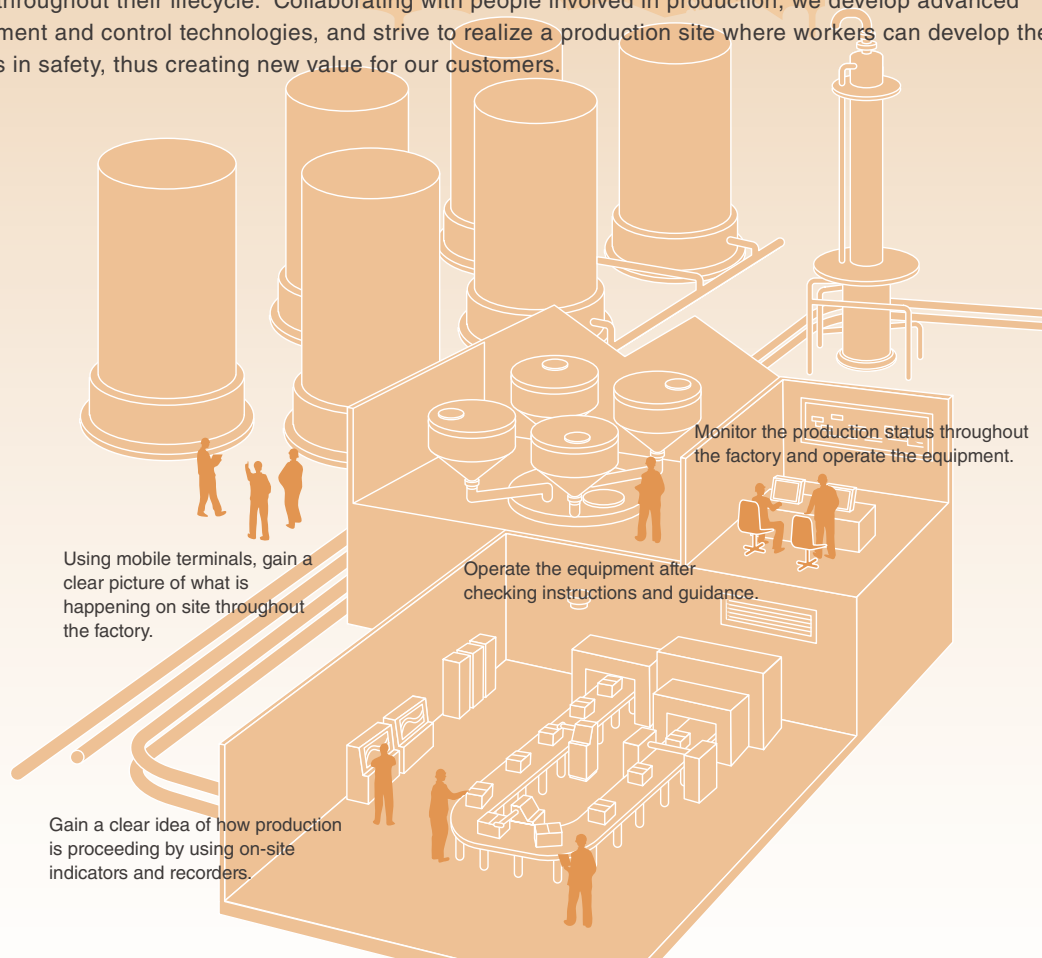

Please read "Terms and Conditions" from the following URL before ordering and use.

<http://www.azbil.com/products/factory/order.html>

HART is a registered trademark of FieldComm Group.
Other product names, model numbers and company names may be trademarks of the respective company.

[Notice] Specifications are subject to change without notice.
No part of this publication may be reproduced or duplicated without the prior written permission of Azbil Corporation.

Azbil Corporation Advanced Automation Company

Yamatate Corporation changed its name to Azbil Corporation on April 1, 2012.

1-12-2 Kawana, Fujisawa
Kanagawa 251-8522 Japan
URL: <http://www.azbil.com>

1st Edition : issued in Oct. 2015-AZ
3rd Edition : issued in May. 2017-AZ/ED